

SIEMENS

Equipment Manual

SINAMICS

S120

Booksize Power Units

Edition

11/2017

www.siemens.com/drives

SIEMENS

SINAMICS

S120 Booksize Power Units

Manual

Preface

Fundamental safety instructions 1

System overview 2

Line connection and line-side power components 3

Line Modules Booksize 4

Line Modules Booksize Compact 5

Motor Modules Booksize 6

Motor Modules Booksize Compact 7

DC link components 8

Braking resistors 9

Motor-side power components 10

Accessories 11

Cabinet design and EMC Booksize 12

Cooling circuit and coolant properties 13

Service and Support Booksize 14

Appendix A

11/2017

6SL3097-4AC00-1BP0

Legal information

Warning notice system

This manual contains notices you have to observe in order to ensure your personal safety, as well as to prevent damage to property. The notices referring to your personal safety are highlighted in the manual by a safety alert symbol, notices referring only to property damage have no safety alert symbol. These notices shown below are graded according to the degree of danger.

 DANGER
indicates that death or severe personal injury will result if proper precautions are not taken.

 WARNING
indicates that death or severe personal injury may result if proper precautions are not taken.

 CAUTION
indicates that minor personal injury can result if proper precautions are not taken.

NOTICE
indicates that property damage can result if proper precautions are not taken.

If more than one degree of danger is present, the warning notice representing the highest degree of danger will be used. A notice warning of injury to persons with a safety alert symbol may also include a warning relating to property damage.

Qualified Personnel

The product/system described in this documentation may be operated only by **personnel qualified** for the specific task in accordance with the relevant documentation, in particular its warning notices and safety instructions. Qualified personnel are those who, based on their training and experience, are capable of identifying risks and avoiding potential hazards when working with these products/systems.

Proper use of Siemens products

Note the following:

 WARNING
Siemens products may only be used for the applications described in the catalog and in the relevant technical documentation. If products and components from other manufacturers are used, these must be recommended or approved by Siemens. Proper transport, storage, installation, assembly, commissioning, operation and maintenance are required to ensure that the products operate safely and without any problems. The permissible ambient conditions must be complied with. The information in the relevant documentation must be observed.

Trademarks

All names identified by ® are registered trademarks of Siemens AG. The remaining trademarks in this publication may be trademarks whose use by third parties for their own purposes could violate the rights of the owner.

Disclaimer of Liability

We have reviewed the contents of this publication to ensure consistency with the hardware and software described. Since variance cannot be precluded entirely, we cannot guarantee full consistency. However, the information in this publication is reviewed regularly and any necessary corrections are included in subsequent editions.

Preface

SINAMICS documentation

The SINAMICS documentation is organized in the following categories:

- General documentation/catalogs
- User documentation
- Manufacturer/service documentation

Additional information

You can find information on the following topics at the following address (<https://support.industry.siemens.com/cs/de/en/view/108993276>):

- Ordering documentation/overview of documentation
- Additional links to download documents
- Using documentation online (find and search in manuals/information)

Please send any questions about the technical documentation (e.g. suggestions for improvement, corrections) to the following e-mail address (<mailto:docu.motioncontrol@siemens.com>).

Siemens MySupport/Documentation

At the following address (<https://support.industry.siemens.com/My/ww/en/documentation>), you can find information on how to create your own individual documentation based on Siemens' content, and adapt it for your own machine documentation.

Training

At the following address (<http://www.siemens.com/sitrain>), you can find information about SITRAIN (Siemens training on products, systems and solutions for automation and drives).

FAQs

You can find Frequently Asked Questions in the Service&Support pages under Product Support (<https://support.industry.siemens.com/cs/de/en/ps/faq>).

SINAMICS

You can find information about SINAMICS at the following address (<http://www.siemens.com/sinamics>).

Usage phases and their documents/tools (as an example)

Table 1 Usage phases and the available documents/tools

Usage phase	Document/tool
Orientation	SINAMICS S Sales Documentation
Planning/configuration	<ul style="list-style-type: none"> • SIZER Engineering Tool • Configuration Manuals, Motors
Deciding/ordering	SINAMICS S120 catalogs <ul style="list-style-type: none"> • SINAMICS S120 and SIMOTICS (Catalog D 21.4) • SINAMICS Converters for Single-Axis Drives and SIMOTICS Motors (Catalog D 31) • SINUMERIK 840 Equipment for Machine Tools (Catalog NC 62)
Installation/assembly	<ul style="list-style-type: none"> • SINAMICS S120 Manual for Control Units and Additional System Components • SINAMICS S120 Manual for Booksize Power Units • SINAMICS S120 Manual for Booksize Power Units C/D Type • SINAMICS S120 Manual for Chassis Power Units, Air-cooled • SINAMICS S120 Manual for Chassis Power Units, Liquid-cooled • SINAMICS S120 Manual for AC Drives • SINAMICS S120 Manual Combi • SINAMICS S120M Manual Distributed Drive Technology • SINAMICS HLA System Manual Hydraulic Drive
Commissioning	<ul style="list-style-type: none"> • STARTER Commissioning Tool • Startdrive commissioning tool • SINAMICS S120 Getting Started with STARTER • SINAMICS S120 Getting Started with Startdrive • SINAMICS S120 Commissioning Manual with STARTER • SINAMICS S120 Commissioning Manual with Startdrive • SINAMICS S120 CANopen Commissioning Manual • SINAMICS S120 Function Manual Drive Functions • SINAMICS S120 Safety Integrated Function Manual • SINAMICS S120/S150 List Manual • SINAMICS HLA System Manual Hydraulic Drive
Usage/operation	<ul style="list-style-type: none"> • SINAMICS S120 Commissioning Manual with STARTER • SINAMICS S120 Commissioning Manual with Startdrive • SINAMICS S120/S150 List Manual • SINAMICS HLA System Manual Hydraulic Drive
Maintenance/servicing	<ul style="list-style-type: none"> • SINAMICS S120 Commissioning Manual with STARTER • SINAMICS S120 Commissioning Manual with Startdrive • SINAMICS S120/S150 List Manual
References	<ul style="list-style-type: none"> • SINAMICS S120/S150 List Manual

Target group

This documentation is intended for machine manufacturers, commissioning engineers, and service personnel who use the SINAMICS drive system.

Benefits

This manual provides all of the information, procedures and operator actions required for the particular usage phase.

Standard scope

The scope of the functionality described in this document can differ from that of the drive system that is actually supplied.

- Other functions not described in this documentation might be able to be executed in the drive system. However, no claim can be made regarding the availability of these functions when the equipment is first supplied or in the event of service.
- The documentation can also contain descriptions of functions that are not available in a particular product version of the drive system. The functionality of the supplied drive system should only be taken from the ordering documentation.
- Extensions or changes made by the machine manufacturer must be documented by the machine manufacturer.

For reasons of clarity, this documentation does not contain all of the detailed information on all of the product types, and cannot take into consideration every conceivable type of installation, operation and service/maintenance.

Technical Support

Country-specific telephone numbers for technical support are provided in the Internet at the following address (<https://support.industry.siemens.com/sc/ww/en/sc/2090>) in the "Contact" area.

Relevant directives and standards

You can obtain an up-to-date list of currently certified components on request from your local Siemens office. If you have any questions relating to certifications that have not yet been completed, please ask your Siemens contact person.

Certificates for download

The certificates can be downloaded from the Internet:

Certificates (<https://support.industry.siemens.com/cs/ww/de/ps/13206/cert>)



EC Declaration of Conformity

You can find the EC Declaration of Conformity for the relevant directives as well as the relevant certificates, prototype test certificates, manufacturers declarations and test certificates for functions relating to functional safety ("Safety Integrated") on the Internet at the following address (<https://support.industry.siemens.com/cs/ww/en/ps/13231/cert>).

The following directives and standards are relevant for SINAMICS S devices:

- **European Low Voltage Directive**

SINAMICS S devices fulfil the requirements stipulated in the Low-Voltage Directive 2014/35/EU, insofar as they are covered by the application area of this directive.

- **European Machinery Directive**

SINAMICS S devices fulfil the requirements stipulated in the Low-Voltage Directive 2006/42/EU, insofar as they are covered by the application area of this directive.

However, the use of the SINAMICS S devices in a typical machine application has been fully assessed for compliance with the main regulations in this directive concerning health and safety.

- **Directive 2011/65/EU**

SINAMICS S devices comply with the requirements of Directive 2011/65/EU on the restriction of the use of certain hazardous substances in electrical and electronic devices (RoHS II).

- **European EMC Directive**

SINAMICS S devices comply with the EMC Directive 2014/30/EU.

- **EMC requirements for South Korea**

SINAMICS S devices with the KC marking on the type plate satisfy the EMC requirements for South Korea.

- **Eurasian conformity**

SINAMICS S comply with the requirements of the Russia/Belarus/Kazakhstan customs union (EAC).

- **North American market**

SINAMICS S devices provided with one of the test symbols displayed fulfill the requirements stipulated for the North American market as a component of drive applications.

You can find the relevant certificates on the Internet pages of the certifier (<http://database.ul.com/cgi-bin/XYV/template/LISEXT/1FRAME/index.html>).

- **Specification for semiconductor process equipment voltage drop immunity**

SINAMICS S devices meet the requirements of standard SEMI F47-0706.

- **Australia and New Zealand (RCM formerly C-Tick)**

SINAMICS S devices showing the test symbols fulfill the EMC requirements for Australia and New Zealand.

- **Quality systems**

Siemens AG employs a quality management system that meets the requirements of ISO 9001 and ISO 14001.



Not relevant standards



China Compulsory Certification

SINAMICS S devices do not fall in the area of validity of the China Compulsory Certification (CCC).

EMC limit values in South Korea

이 기기는 업무용(A급) 전자과적합기기로서 판매자 또는 사용자는 이 점을 주의하시기 바라며, 가정외의 지역에서 사용하는 것을 목적으로 합니다.

For sellers or other users, please bear in mind that this device is an A-grade electromagnetic wave device. This device is intended to be used in areas other than at home.

The EMC limit values to be observed for Korea correspond to the limit values of the EMC product standard for variable-speed electric drives EN 61800-3 of category C2 or the limit value class A, Group 1 to KN11. By implementing appropriate additional measures, the limit values according to category C2 or limit value class A, Group 1, are observed. Further, additional measures may be required, such as using an additional radio interference suppression filter (EMC filter).

The measures for EMC-compliant design of the system are described in detail in this manual respectively in the EMC Installation Guideline Configuration Manual.

The final statement regarding compliance with the standard is given by the respective label attached to the individual unit.

Ensuring reliable operation

The manual describes a desired state which, if maintained, ensures the required level of operational reliability and compliance with EMC limit values.

Should there be any deviation from the requirements in the manual, appropriate actions (e.g. measurements) must be taken to check/prove that the required level of operational reliability and compliance with EMC limit values are ensured.

Spare parts

Spare parts are available on the Internet at the following address (<https://www.automation.siemens.com/sow?sap-language=EN>).

Product maintenance

The components are subject to continuous further development within the scope of product maintenance (improvements to robustness, discontinuations of components, etc).

These further developments are "spare parts-compatible" and do not change the article number.

In the scope of such spare parts-compatible further developments, connector/connection positions are sometimes changed slightly. This does not cause any problems with proper use of the components. Please take this fact into consideration in special installation situations (e.g. allow sufficient clearance for the cable length).

Use of third-party products

This document contains recommendations relating to third-party products. Siemens accepts the fundamental suitability of these third-party products.

You can use equivalent products from other manufacturers.

Siemens does not accept any warranty for the properties of third-party products.

Ground symbols

Table 2 Symbols



Symbol	Meaning
	Connection for protective conductor
	Ground (e.g. M 24 V)
	Connection for function potential bonding

Table of contents

	Preface	3
1	Fundamental safety instructions	23
1.1	General safety instructions	23
1.2	Equipment damage due to electric fields or electrostatic discharge	28
1.3	Warranty and liability for application examples	28
1.4	Industrial security	29
1.5	Residual risks of power drive systems.....	30
2	System overview.....	31
2.1	Field of application	31
2.2	Platform Concept and Totally Integrated Automation	32
2.3	Introduction	34
2.4	SINAMICS S120 components	36
2.4.1	Overview of Line Modules	39
2.4.2	Overview of Motor Modules	41
2.5	System data	42
3	Line connection and line-side power components.....	45
3.1	Introduction	45
3.2	Information on the disconnecter unit.....	46
3.3	Overcurrent protection using fuses and circuit breakers	47
3.4	Line supply connection via residual-current devices	47
3.4.1	Residual current protective devices (RCD).....	48
3.4.2	Modular residual current protective devices (MRCD).....	50
3.5	Line contactors.....	52
3.6	Line filters.....	53
3.6.1	Safety instructions for line filters	53
3.6.2	Overview of line filters	55
3.6.3	Basic Line Filters for Active Line Modules	56
3.6.3.1	Description	56
3.6.3.2	Interface description.....	57
3.6.3.3	Dimension drawings.....	58
3.6.3.4	Technical data.....	61
3.6.4	Basic Line Filter for Basic Line Modules.....	62
3.6.4.1	Description	62
3.6.4.2	Interface description.....	63
3.6.4.3	Dimension drawings.....	64
3.6.4.4	Technical specifications	66
3.6.5	Basic Line Filter for Smart Line Modules	67

3.6.5.1	Description	67
3.6.5.2	Interface description.....	68
3.6.5.3	Dimension drawings.....	69
3.6.5.4	Technical data.....	71
3.7	Line reactors	72
3.7.1	Safety instructions for line reactors.....	72
3.7.2	Overview of the line reactors	73
3.7.3	Line reactors for Active Line Modules.....	75
3.7.3.1	Interface description.....	75
3.7.3.2	Dimension drawings.....	79
3.7.3.3	Technical data.....	84
3.7.4	Damping resistor for HFD line reactors	84
3.7.4.1	Description	84
3.7.4.2	Safety instructions for damping resistors for HFD reactors	85
3.7.4.3	Dimension drawings.....	85
3.7.4.4	Technical data.....	87
3.7.4.5	Wiring with the HFD line reactor	88
3.7.5	Line reactors for Basic Line Modules.....	89
3.7.5.1	Interface description.....	89
3.7.5.2	Dimension drawings.....	92
3.7.5.3	Technical data.....	95
3.7.6	Line reactors for Smart Line Modules.....	95
3.7.6.1	Interface description.....	95
3.7.6.2	Dimension drawings.....	97
3.7.6.3	Technical data.....	100
3.8	Active Interface Modules internal air cooling	101
3.8.1	Description	101
3.8.2	Safety instructions for Active Interface Modules.....	102
3.8.3	Interface description.....	104
3.8.3.1	Overview	104
3.8.3.2	Line/load connection.....	107
3.8.3.3	X121 temperature sensor and fan control	108
3.8.3.4	X124 Electronics power supply.....	109
3.8.4	Connection example	109
3.8.5	Dimension drawings.....	110
3.8.6	Installation	114
3.8.7	Operation on an isolated-neutral system (IT system)	118
3.8.8	Operation on networks with asymmetrical grounding.....	118
3.8.9	Removing the connecting screw for the interference suppression capacitor	119
3.8.10	Technical data.....	120
3.9	Combination options, Line Modules with line reactors and line filters	120
3.10	Line connection variants	123
3.10.1	Ways of connecting the line supply.....	123
3.10.2	Operating line connection components on the line supply	124
3.10.3	Operation of the line connection components via a transformer	125
3.10.3.1	Safety instructions for line connection components.....	125
3.10.3.2	Line supply connection conditions for Line Modules	126
3.10.3.3	Dimensioning an isolating transformer / autotransformer for several loads	127
3.10.3.4	Operating line connection components via an autotransformer	131
3.10.3.5	Operating line connection components via an isolating transformer	132

4	Line Modules Booksize	135
4.1	Safety instructions for Line Modules Booksize	135
4.2	Frequency with which the DC link is precharged	139
4.3	Active Line Modules with internal air cooling	139
4.3.1	Description	139
4.3.2	Interface description	140
4.3.2.1	Overview	140
4.3.2.2	X1 line connection	141
4.3.2.3	X12 fan connection	142
4.3.2.4	X21 EP terminals	142
4.3.2.5	X24 24 V terminal adapter	143
4.3.2.6	X200-X202 DRIVE-CLiQ interfaces	143
4.3.3	Connection example	144
4.3.4	Meaning of LEDs	145
4.3.5	Dimension drawings	146
4.3.6	Installation	150
4.3.7	Technical data	152
4.3.7.1	Characteristics	155
4.4	Active Line Modules with external air cooling	157
4.4.1	Description	157
4.4.2	Interface description	158
4.4.2.1	Overview	158
4.4.2.2	X1 line connection	159
4.4.2.3	X12 fan connection	160
4.4.2.4	X21 EP terminals	160
4.4.2.5	X24 24 V terminal adapter	161
4.4.2.6	X200-X202 DRIVE-CLiQ interfaces	161
4.4.3	Connection example	162
4.4.4	Meaning of LEDs	163
4.4.5	Dimension drawings	164
4.4.6	Installation	167
4.4.6.1	Mounting examples	170
4.4.7	Technical data	173
4.4.7.1	Characteristics	176
4.5	Active Line Modules with cold plate	178
4.5.1	Description	178
4.5.2	Interface description	179
4.5.2.1	Overview	179
4.5.2.2	X1 line connection	180
4.5.2.3	X21 EP terminals	181
4.5.2.4	X24 24 V terminal adapter	182
4.5.2.5	X200-X202 DRIVE-CLiQ interfaces	182
4.5.3	Connection example	183
4.5.4	Meaning of LEDs	184
4.5.5	Dimension drawings	185
4.5.6	Mounting	187
4.5.7	Technical data	190
4.5.7.1	Characteristics	192
4.6	Active Line Modules Liquid Cooled	194

4.6.1	Description	194
4.6.2	Interface description.....	195
4.6.2.1	Overview	195
4.6.2.2	X1 line connection.....	196
4.6.2.3	X21 EP terminals	196
4.6.2.4	X24 24 V terminal adapter	197
4.6.2.5	X200-X202 DRIVE-CLiQ interfaces	198
4.6.3	Connection example	199
4.6.4	Meaning of LEDs.....	200
4.6.5	Dimension drawing	201
4.6.6	Installation	202
4.6.7	Technical data.....	203
4.6.7.1	Characteristics	205
4.7	Basic Line Modules with internal air cooling	206
4.7.1	Description	206
4.7.2	Interface description.....	207
4.7.2.1	Overview	207
4.7.2.2	X1 line connection.....	208
4.7.2.3	X2 braking resistor connection.....	209
4.7.2.4	X21 EP terminals	210
4.7.2.5	X24 24 V terminal adapter	211
4.7.2.6	X200-X202 DRIVE-CLiQ interfaces	212
4.7.3	Connection examples	213
4.7.4	Meaning of LEDs.....	215
4.7.5	Dimension drawings.....	216
4.7.6	Installation	219
4.7.7	Operation on an isolated-neutral system (IT system)	220
4.7.8	Operation on networks with asymmetrical grounding	220
4.7.9	Removing the connection clip for the interference suppression capacitor	221
4.7.10	Technical data.....	222
4.7.10.1	Characteristics	223
4.8	Basic Line Modules with cold plate	225
4.8.1	Description	225
4.8.2	Interface description.....	226
4.8.2.1	Overview	226
4.8.2.2	X1 line connection.....	227
4.8.2.3	X2 braking resistor connection.....	228
4.8.2.4	X21 EP terminals	229
4.8.2.5	X24 24 V terminal adapter	230
4.8.2.6	X200-X202 DRIVE-CLiQ interfaces	231
4.8.3	Connection examples	232
4.8.4	Meaning of LEDs.....	234
4.8.5	Dimension drawings.....	235
4.8.6	Mounting	238
4.8.7	Operation on an isolated-neutral system (IT system)	241
4.8.8	Operation on networks with asymmetrical grounding	242
4.8.9	Removing the connection clip for the interference suppression capacitor	242
4.8.10	Technical data.....	243
4.8.10.1	Characteristics	245
4.9	Smart Line Modules with internal air cooling	247
4.9.1	Description	247

4.9.2	Additional safety instructions for Smart Line Modules Booksize	247
4.9.3	Switch-on/switch-off sequence for 5 kW and 10 kW Smart Line Modules	248
4.9.4	Interface description.....	249
4.9.4.1	Overview	249
4.9.4.2	X1 line connection.....	252
4.9.4.3	X21 EP terminals	254
4.9.4.4	X22 digital inputs.....	256
4.9.4.5	X24 24 V terminal adapter	257
4.9.4.6	X200-X202 DRIVE-CLiQ interfaces.....	257
4.9.5	Connection examples	258
4.9.6	Meaning of LEDs	260
4.9.6.1	Smart Line Modules 5 kW and 10 kW	260
4.9.6.2	16 kW to 55 kW Smart Line Modules	261
4.9.7	Dimension drawings.....	262
4.9.8	Installation.....	266
4.9.9	Technical data.....	267
4.9.9.1	Characteristics	269
4.10	Smart Line Modules with external air cooling	270
4.10.1	Description	270
4.10.2	Additional safety instructions for Smart Line Modules Booksize	271
4.10.3	Switch-on/switch-off sequence for 5 kW and 10 kW Smart Line Modules	272
4.10.4	Interface description.....	273
4.10.4.1	Overview	273
4.10.4.2	X1 line connection.....	276
4.10.4.3	X21 EP terminals	278
4.10.4.4	X22 digital inputs.....	280
4.10.4.5	X24 24 V terminal adapter	281
4.10.4.6	X200-X202 DRIVE-CLiQ interfaces.....	281
4.10.5	Connection examples	282
4.10.6	Meaning of LEDs	284
4.10.6.1	Smart Line Modules 5 kW and 10 kW	284
4.10.6.2	16 kW to 55 kW Smart Line Modules	284
4.10.7	Dimension drawings.....	285
4.10.8	Mounting	289
4.10.9	Technical data.....	294
4.10.9.1	Characteristics	296
4.11	Smart Line Modules with cold plate	296
4.11.1	Description	296
4.11.2	Additional safety instructions for Smart Line Modules Booksize	297
4.11.3	Switch-on/switch-off sequence for 5 kW and 10 kW Smart Line Modules	298
4.11.4	Interface description.....	299
4.11.4.1	Overview	299
4.11.4.2	X1 line connection.....	300
4.11.4.3	X21 EP terminals	300
4.11.4.4	X22 digital inputs.....	302
4.11.4.5	X24 24 V terminal adapter	302
4.11.5	Connection example	303
4.11.6	Meaning of LEDs	304
4.11.7	Dimension drawings.....	305
4.11.8	Mounting	306
4.11.9	Technical data.....	308

4.11.9.1	Characteristics	310
4.11.9.2	Measuring the heat sink temperature	311
5	Line Modules Booksize Compact	313
5.1	Frequency with which the DC link is precharged	313
5.2	Smart Line Modules Booksize Compact	313
5.2.1	Description	313
5.2.2	Safety instructions for Smart Line Modules Booksize Compact	314
5.2.3	Interface description	317
5.2.3.1	Overview	317
5.2.3.2	X1 line connection	318
5.2.3.3	X21 EP terminals	318
5.2.3.4	X24 24 V terminal adapter	319
5.2.3.5	X200-X202 DRIVE-CLiQ interfaces	320
5.2.4	Connection example	321
5.2.5	Meaning of the LEDs	322
5.2.6	Dimension drawing	323
5.2.7	Mounting	324
5.2.8	Technical data	326
5.2.8.1	Characteristics	328
6	Motor Modules Booksize	329
6.1	Safety instructions for Motor Modules Booksize	329
6.2	Motor Modules with internal air cooling	333
6.2.1	Description	333
6.2.2	Interface description	334
6.2.2.1	Overview	334
6.2.2.2	Motor and brake connection	336
6.2.2.3	X12 fan connection	339
6.2.2.4	X21/X22 EP terminals/temperature sensor	339
6.2.2.5	X200-X203 DRIVE-CLiQ interface	340
6.2.3	Connection examples	341
6.2.4	Meaning of LEDs	343
6.2.5	Dimension drawings	344
6.2.6	Installation	349
6.2.7	Technical data	351
6.2.7.1	Single Motor Modules	351
6.2.7.2	Double Motor Modules	353
6.2.7.3	Characteristics	354
6.2.8	Technical data for Motor Modules Booksize with 300% overload	357
6.2.8.1	Single Motor Modules (300% overload)	357
6.2.8.2	Double Motor Modules (300% overload)	358
6.2.8.3	Characteristics for Motor Modules Booksize with 300% overload	359
6.3	Motor Module with external air cooling	363
6.3.1	Description	363
6.3.2	Interface description	364
6.3.2.1	Overview	364
6.3.2.2	Motor and brake connection	366
6.3.2.3	X12 fan connection	369
6.3.2.4	X21/X22 EP terminals/temperature sensor	369
6.3.2.5	X200-X203 DRIVE-CLiQ interface	370

6.3.3	Connection examples	371
6.3.4	Meaning of LEDs	373
6.3.5	Dimension drawings.....	374
6.3.6	Mounting	379
6.3.7	Technical data.....	386
6.3.7.1	Single Motor Modules	386
6.3.7.2	Double Motor Modules.....	388
6.3.7.3	Characteristics	389
6.3.8	Technical data for Motor Modules Booksize with 300% overload	392
6.3.8.1	Single Motor Modules (300% overload).....	392
6.3.8.2	Double Motor Modules (300% overload)	393
6.3.8.3	Characteristics for Motor Modules Booksize with 300% overload.....	395
6.4	Motor Modules with cold plate	398
6.4.1	Description	398
6.4.2	Interface description.....	399
6.4.2.1	Overview	399
6.4.2.2	Motor and brake connection	401
6.4.2.3	X21/X22 EP terminals/temperature sensor	404
6.4.2.4	X200-X203 DRIVE-CLiQ interface.....	405
6.4.3	Connection examples	406
6.4.4	Meaning of LEDs	408
6.4.5	Dimension drawings.....	409
6.4.6	Mounting	413
6.4.7	Technical data.....	416
6.4.7.1	Single Motor Modules	416
6.4.7.2	Double Motor Modules.....	418
6.4.7.3	Characteristics	419
6.4.8	Technical data for Motor Modules Booksize with 300% overload	422
6.4.8.1	Single Motor Modules (300% overload).....	422
6.4.8.2	Double Motor Modules (300% overload)	423
6.4.8.3	Characteristics for Motor Modules Booksize with 300% overload.....	424
6.5	Motor Modules Liquid Cooled	427
6.5.1	Description	427
6.5.2	Interface description.....	428
6.5.2.1	Overview	428
6.5.2.2	Motor and brake connection	429
6.5.2.3	X21 EP terminal/temperature sensor.....	431
6.5.2.4	X200-X202 DRIVE-CLiQ interface.....	432
6.5.3	Connection example	433
6.5.4	Meaning of LEDs	433
6.5.5	Dimension drawing	434
6.5.6	Installation.....	435
6.5.7	Technical data.....	436
6.5.7.1	Characteristics	437
7	Motor Modules Booksize Compact.....	441
7.1	Description	441
7.2	Safety instructions for Motor Modules Booksize Compact	441
7.3	Interface description.....	445
7.3.1	Overview	445

7.3.2	X1/X2 motor connection.....	447
7.3.3	X11/X12 motor brake connection.....	447
7.3.4	X21/X22 EP terminals/temperature sensor	449
7.3.5	X200-X203 DRIVE-CLiQ interface.....	450
7.4	Connection example	451
7.5	Meaning of LEDs.....	452
7.6	Dimension drawings.....	453
7.7	Mounting	456
7.8	Technical data.....	459
7.8.1	Single Motor Modules	459
7.8.2	Double Motor Modules.....	460
7.8.3	Characteristics	462
8	DC link components.....	467
8.1	Safety instructions for DC link components	467
8.2	Braking Module Booksize	469
8.2.1	Description	469
8.2.2	Safety instructions for Braking Modules Booksize.....	470
8.2.3	Interface description.....	471
8.2.3.1	Overview	471
8.2.3.2	X1 braking resistor connection.....	472
8.2.3.3	X21 digital inputs/outputs.....	472
8.2.4	Connection example	474
8.2.5	Meaning of LEDs.....	475
8.2.6	Dimension drawing	476
8.2.7	Installation.....	477
8.2.8	Technical data.....	478
8.2.8.1	Characteristic curves	478
8.2.9	Configuration instructions	479
8.3	Braking Module Booksize Compact.....	480
8.3.1	Description	480
8.3.2	Safety instructions for Braking Modules Booksize Compact	482
8.3.3	Interface description.....	483
8.3.3.1	Overview	483
8.3.3.2	X1 braking resistor connection.....	484
8.3.3.3	X21 digital inputs/outputs.....	485
8.3.3.4	X22 digital output/temperature switch.....	486
8.3.3.5	DIP switch	487
8.3.4	Connection examples	488
8.3.5	Meaning of LEDs.....	490
8.3.6	Dimension drawing	491
8.3.7	Mounting	492
8.3.8	Technical specifications	494
8.3.8.1	Characteristic curves	495
8.3.9	Configuration instructions	496
8.4	Braking units for 100 kW Basic Line Modules	497
8.4.1	Description	497
8.4.2	Safety instructions for Braking Modules for the 100 kW Basic Line Module	497

8.4.3	Interface description.....	498
8.4.3.1	X3 DC link connection.....	498
8.4.3.2	X6 braking resistor connection	499
8.4.3.3	Switch S1	499
8.4.4	Connection example	500
8.4.5	Dimension drawing	501
8.4.6	Connection to the Basic Line Module 100 kW.....	502
8.5	Capacitor Module.....	504
8.5.1	Description	504
8.5.2	Interface description.....	505
8.5.2.1	Overview	505
8.5.3	Dimension drawing	506
8.5.4	Mounting	507
8.5.5	Technical Specifications	508
8.6	Control Supply Module CSM	509
8.6.1	Description	509
8.6.2	Safety instructions for Control Supply Modules	510
8.6.3	Interface description.....	512
8.6.3.1	Overview	512
8.6.3.2	X1 line connection.....	513
8.6.3.3	X21 signaling contact.....	513
8.6.3.4	X24 24 V terminal adapter	514
8.6.3.5	S1 DIP switch.....	514
8.6.4	Connection examples	515
8.6.4.1	Single operation	516
8.6.4.2	Parallel operation	518
8.6.5	Meaning of LEDs	523
8.6.6	Dimension drawing	524
8.6.7	Installation.....	525
8.6.8	Technical data.....	526
8.6.8.1	Characteristics	527
9	Braking resistors	529
9.1	Description	529
9.2	Safety instructions for braking resistors.....	530
9.3	Dimension drawings and installation	531
9.4	Technical data.....	537
9.4.1	Characteristic curves	539
10	Motor-side power components	541
10.1	Motor reactors.....	541
10.1.1	Description	541
10.1.2	Safety instructions for motor reactors.....	542
10.1.3	Dimension drawings.....	543
10.1.4	Technical data.....	548
10.2	Voltage Protection Module VPM.....	550
10.2.1	Description	550
10.2.2	Safety instructions for Voltage Protection Modules	551
10.2.3	Interface description.....	553

10.2.3.1	Overview	553
10.2.3.2	X3 signaling contact.....	555
10.2.3.3	Connection bars U, V, W, PE.....	556
10.2.4	Connection examples	557
10.2.5	Dimension drawings.....	559
10.2.6	Installation	561
10.2.7	Electrical connection	563
10.2.7.1	Connecting signaling contact X3.....	564
10.2.7.2	Connecting power cables (using the VPM 200 Dynamik as an example).....	565
10.2.8	Technical data.....	568
11	Accessories	569
11.1	Shield connecting plates for power supply and motor cables.....	569
11.1.1	Description	569
11.1.2	Shield connecting plates	569
11.1.3	Overview examples.....	572
11.1.4	Dimension drawings.....	576
11.1.4.1	Line Modules and Motor Modules with internal air cooling	576
11.1.4.2	Line Modules and Motor Modules with external air cooling	580
11.1.4.3	Line Modules and Motor Modules with cold plate.....	584
11.1.4.4	Line Modules and Motor Modules, Liquid Cooled.....	588
11.1.4.5	Active Interface Modules.....	589
11.1.5	Installation	593
11.1.6	Connecting the power cables.....	596
11.2	Releasing the DC link protective cover	598
11.3	Reinforced DC link busbars	599
11.3.1	Description	599
11.3.2	Safety instructions for reinforced DC link busbars.....	600
11.3.3	Dimension drawings.....	601
11.3.4	Removing the DC link busbars	602
11.3.5	Installing the reinforced DC link busbars	603
11.4	DC link rectifier adapter for Booksize format	605
11.4.1	Description	605
11.4.2	Safety instructions for DC link rectifier adapters.....	606
11.4.3	Interface description.....	608
11.4.3.1	Overview	608
11.4.3.2	DC link connection	609
11.4.4	Dimension drawings.....	609
11.4.5	Mounting	611
11.4.5.1	Installation on components that are 50 mm and 100 mm wide	611
11.4.5.2	Installation on components that are 150 mm, 200 mm and 300 mm wide	613
11.4.6	Electrical connection	615
11.4.7	Technical specifications	616
11.5	DC link adapter	617
11.5.1	Description	617
11.5.2	Safety instructions for DC link adapters.....	618
11.5.3	Interface description.....	620
11.5.3.1	Overview	620
11.5.3.2	DC link connection	621
11.5.4	Dimension drawing	622

11.5.5	Installation	623
11.5.6	Electrical connection	627
11.5.6.1	Preparing the cables	627
11.5.6.2	Fixing the cables to the rear cabinet panel	628
11.5.6.3	Cable connection and shield support.....	629
11.5.7	Technical specifications	631
11.6	DRIVE-CLiQ cabinet bushings	631
11.6.1	Description	631
11.6.2	Interface description.....	632
11.6.2.1	Overview	632
11.6.3	Dimension drawings.....	633
11.6.4	Mounting	634
11.6.4.1	DRIVE-CLiQ cabinet bushing for cables with RJ45 connectors	634
11.6.4.2	DRIVE-CLiQ cabinet bushing for cables with M12 plug/socket.....	636
11.6.5	Technical data.....	637
11.7	DRIVE-CLiQ coupling	638
11.7.1	Description	638
11.7.2	Interface description.....	638
11.7.2.1	Overview	638
11.7.3	Dimension drawing	639
11.7.4	Mounting	639
11.7.5	Technical data.....	640
11.8	Spacing bolt for Booksize Compact components	640
12	Cabinet design and EMC Booksize	643
12.1	General information	643
12.2	Safety instructions when mounting and installing the control cabinet	644
12.3	Electromagnetic compatibility	644
12.3.1	General information	644
12.3.2	Environments and categories	645
12.3.3	Drive system applications	646
12.4	Arrangement of components and equipment	648
12.4.1	General information	648
12.4.2	Current carrying capacity of the DC link busbar	649
12.4.3	Single-tier drive line-up	652
12.4.4	Multi-tier drive line-up.....	654
12.4.4.1	Arrangement rules	654
12.4.4.2	Selecting the DC link rectifier adapter and DC link adapter	655
12.4.4.3	Connection versions for the DC link adapter	655
12.4.4.4	Examples of a multi-tier configuration.....	660
12.4.4.5	Connection example	662
12.5	Electrical connection	663
12.5.1	Connecting DC link busbars	663
12.5.2	Connection of the 24 V busbars	667
12.5.3	Installation of the 24 V terminal adapter	668
12.5.4	Shield connection for terminals X21/X22 on the Motor Module	670
12.6	24 V DC supply voltage	671
12.6.1	General information	671

12.6.2	Options for the 24 V supply of the components	673
12.6.3	Overcurrent protection	674
12.6.4	Overvoltage protection	675
12.6.5	Typical 24 V current consumption of the components	677
12.6.6	Selecting power supply units	682
12.7	Connection systems	683
12.7.1	DRIVE-CLiQ signal cables	683
12.7.1.1	Overview	683
12.7.1.2	DRIVE-CLiQ signal cables without 24 V DC cores	684
12.7.1.3	DRIVE-CLiQ signal cables MOTION-CONNECT with RJ45 connectors	684
12.7.1.4	DRIVE-CLiQ signal cables MOTION-CONNECT with RJ45 plug and M12 socket	685
12.7.1.5	Comparison of DRIVE-CLiQ signal cables	687
12.7.1.6	Connecting a direct measuring system	688
12.7.1.7	Combined use of MOTION-CONNECT 500 and MOTION-CONNECT 800PLUS	689
12.7.2	Power cables for motors	690
12.7.2.1	Configuring the cable length	690
12.7.2.2	Comparison of MOTION-CONNECT power cables	691
12.7.3	Current-carrying capacity and derating factors for power cables and signal cables	692
12.7.4	Maximum cable lengths	694
12.7.5	Connectable conductor cross-sections and tightening torques for motor and power cables	695
12.7.6	Motor connection connector	698
12.7.6.1	Mounting on the Motor Module	698
12.7.6.2	Attaching the motor connector to self-fabricated cables	701
12.7.6.3	Removing the motor connector from prefabricated power cables	705
12.7.6.4	Coding	707
12.7.7	Spring-loaded terminals	708
12.7.8	Screw terminals	708
12.7.9	Cable lugs	710
12.7.10	Handling restrictor collars for touch protection	711
12.8	Cable shielding and routing	712
12.9	Protective connection and equipotential bonding	714
12.10	Information on cold plate cooling	717
12.10.1	General information	717
12.10.2	Cold plate with external air heat sink	719
12.10.2.1	Configuration and conditions	719
12.10.2.2	Setup example, drive line-up, cold plate with external air heat sink	720
12.10.3	Cold plate with an external liquid heat sink	722
12.10.3.1	Configuration and conditions	722
12.10.3.2	Setup example, drive-line-up, cold plate with external liquid heat sink	723
12.11	Notes on electrical cabinet cooling	724
12.11.1	Control cabinet cooling options	724
12.11.2	General information on ventilation	724
12.11.3	Cooling clearances	727
12.11.4	Notes on ventilation with cold plate	732
12.11.5	Dimensioning Climate Control Equipment	733
12.12	Power losses of the components	734
12.12.1	General information	734
12.12.2	Power loss for Control Units, Sensor Modules, and other system components	734

12.12.3	Power loss for line filters and line reactors	735
12.12.4	Power loss for power units with internal air cooling	736
12.12.5	Power loss for power units with external air cooling	737
12.12.6	Power loss for power units with cold plate	738
12.12.7	Power loss for liquid-cooled power units	740
12.12.8	Electronics losses of power units	740
12.12.9	Maximum power losses in the partial load range	742
12.12.10	Typical power losses for Motor Modules	745
13	Cooling circuit and coolant properties	749
13.1	Cooling circuit requirements	749
13.1.1	Technical cooling circuits	749
13.1.2	Cooling system requirements	750
13.1.3	Cooling circuit configuration	751
13.1.4	Installation	754
13.1.5	Preventing cavitation	755
13.1.6	Commissioning	756
13.2	Coolant requirements	757
13.2.1	Coolant properties	757
13.2.2	Corrosion Inhibitor Additive (Inhibiting)	758
13.2.3	Anti-Freeze Additive	759
13.2.4	Biocide additives (only if required)	760
13.3	Anti-condensation measures	761
13.4	Equipotential bonding in the cooling system	762
13.5	Using heat exchangers	762
13.5.1	Water-to-water heat exchanger	762
13.5.2	Air-to-water heat exchanger	763
13.5.3	Active cooling unit	764
14	Service and Support Booksize	765
14.1	Spare parts	765
14.2	Replacing the fan	765
14.2.1	Safety instructions when replacing a fan	765
14.2.2	Replacing the fan for components with internal and external air cooling	766
14.2.3	Replacing the fan on an Active Interface Module	769
14.2.4	Replacing the fan on the 100 kW Basic Line Module for capacitor cooling	770
14.2.5	Replacing the fan for Booksize Compact components	772
14.3	Forming the DC link capacitors	774
14.4	Recycling and disposal	781
A	Appendix	783
A.1	List of abbreviations	783
A.2	Documentation overview	792
	Index	793

Fundamental safety instructions

1.1 General safety instructions



WARNING

Electric shock and danger to life due to other energy sources

Touching live components can result in death or severe injury.

- Only work on electrical devices when you are qualified for this job.
- Always observe the country-specific safety rules.

Generally, the following six steps apply when establishing safety:

1. Prepare for disconnection. Notify all those who will be affected by the procedure.
2. Isolate the drive system from the power supply and take measures to prevent it being switched back on again.
3. Wait until the discharge time specified on the warning labels has elapsed.
4. Check that there is no voltage between any of the power connections, and between any of the power connections and the protective conductor connection.
5. Check whether the existing auxiliary supply circuits are de-energized.
6. Ensure that the motors cannot move.
7. Identify all other dangerous energy sources, e.g. compressed air, hydraulic systems, or water. Switch the energy sources to a safe state.
8. Check that the correct drive system is completely locked.

After you have completed the work, restore the operational readiness in the inverse sequence.



WARNING

Electric shock due to connection to an unsuitable power supply

When equipment is connected to an unsuitable power supply, exposed components may carry a hazardous voltage that might result in serious injury or death.

- Only use power supplies that provide SELV (Safety Extra Low Voltage) or PELV- (Protective Extra Low Voltage) output voltages for all connections and terminals of the electronics modules.



	! WARNING
	Electric shock due to equipment damage
	Improper handling may cause damage to equipment. For damaged devices, hazardous voltages can be present at the enclosure or at exposed components; if touched, this can result in death or severe injury.
	<ul style="list-style-type: none">• Ensure compliance with the limit values specified in the technical data during transport, storage and operation.• Do not use any damaged devices.



	! WARNING
	Electric shock due to unconnected cable shield
	Hazardous touch voltages can occur through capacitive cross-coupling due to unconnected cable shields.
	<ul style="list-style-type: none">• As a minimum, connect cable shields and the conductors of power cables that are not used (e.g. brake cores) at one end at the grounded housing potential.



	! WARNING
	Electric shock if there is no ground connection
	For missing or incorrectly implemented protective conductor connection for devices with protection class I, high voltages can be present at open, exposed parts, which when touched, can result in death or severe injury.
	<ul style="list-style-type: none">• Ground the device in compliance with the applicable regulations.



	! WARNING
	Arcing when a plug connection is opened during operation
	Opening a plug connection when a system is operation can result in arcing that may cause serious injury or death.
	<ul style="list-style-type: none">• Only open plug connections when the equipment is in a voltage-free state, unless it has been explicitly stated that they can be opened in operation.



	! WARNING
	Electric shock due to residual charges in power components
	Because of the capacitors, a hazardous voltage is present for up to 5 minutes after the power supply has been switched off. Contact with live parts can result in death or serious injury.
	<ul style="list-style-type: none">• Wait for 5 minutes before you check that the unit really is in a no-voltage condition and start work.

NOTICE**Property damage due to loose power connections**

Insufficient tightening torques or vibration can result in loose power connections. This can result in damage due to fire, device defects or malfunctions.

- Tighten all power connections to the prescribed torque.
- Check all power connections at regular intervals, particularly after equipment has been transported.

 **WARNING****Spread of fire from built-in devices**

In the event of fire outbreak, the enclosures of built-in devices cannot prevent the escape of fire and smoke. This can result in serious personal injury or property damage.

- Install built-in units in a suitable metal cabinet in such a way that personnel are protected against fire and smoke, or take other appropriate measures to protect personnel.
- Ensure that smoke can only escape via controlled and monitored paths.

 **WARNING****Failure of pacemakers or implant malfunctions due to electromagnetic fields**

Electromagnetic fields (EMF) are generated by the operation of electrical power equipment, such as transformers, converters, or motors. People with pacemakers or implants in the immediate vicinity of this equipment are at particular risk.

- If you have a heart pacemaker or implant, maintain a minimum distance of 2 m from electrical power equipment.

 **WARNING****Unexpected movement of machines caused by radio devices or mobile phones**

When radio devices or mobile phones with a transmission power > 1 W are used in the immediate vicinity of components, they may cause the equipment to malfunction. Malfunctions may impair the functional safety of machines and can therefore put people in danger or lead to property damage.

- If you come closer than around 2 m to such components, switch off any radios or mobile phones.
- Use the "SIEMENS Industry Online Support App" only on equipment that has already been switched off.

 WARNING
Motor fire in the event of insulation overload
There is higher stress on the motor insulation through a ground fault in an IT system. If the insulation fails, it is possible that death or severe injury can occur as a result of smoke and fire.
<ul style="list-style-type: none">• Use a monitoring device that signals an insulation fault.• Correct the fault as quickly as possible so the motor insulation is not overloaded.

 WARNING
Fire due to inadequate ventilation clearances
Inadequate ventilation clearances can cause overheating of components with subsequent fire and smoke. This can cause severe injury or even death. This can also result in increased downtime and reduced service lives for devices/systems.
<ul style="list-style-type: none">• Ensure compliance with the specified minimum clearance as ventilation clearance for the respective component.

 WARNING
Unrecognized dangers due to missing or illegible warning labels
Dangers might not be recognized if warning labels are missing or illegible. Unrecognized dangers may cause accidents resulting in serious injury or death.
<ul style="list-style-type: none">• Check that the warning labels are complete based on the documentation.• Attach any missing warning labels to the components, where necessary in the national language.• Replace illegible warning labels.

NOTICE
Device damage caused by incorrect voltage/insulation tests
Incorrect voltage/insulation tests can damage the device.
<ul style="list-style-type: none">• Before carrying out a voltage/insulation check of the system/machine, disconnect the devices as all converters and motors have been subject to a high voltage test by the manufacturer, and therefore it is not necessary to perform an additional test within the system/machine.

 **WARNING**

Unexpected movement of machines caused by inactive safety functions

Inactive or non-adapted safety functions can trigger unexpected machine movements that may result in serious injury or death.

- Observe the information in the appropriate product documentation before commissioning.
- Carry out a safety inspection for functions relevant to safety on the entire system, including all safety-related components.
- Ensure that the safety functions used in your drives and automation tasks are adjusted and activated through appropriate parameterizing.
- Perform a function test.
- Only put your plant into live operation once you have guaranteed that the functions relevant to safety are running correctly.

Note

Important safety notices for Safety Integrated functions

If you want to use Safety Integrated functions, you must observe the safety notices in the Safety Integrated manuals.

1.2 Equipment damage due to electric fields or electrostatic discharge

Electrostatic sensitive devices (ESD) are individual components, integrated circuits, modules or devices that may be damaged by either electric fields or electrostatic discharge.



NOTICE

Equipment damage due to electric fields or electrostatic discharge

Electric fields or electrostatic discharge can cause malfunctions through damaged individual components, integrated circuits, modules or devices.

- Only pack, store, transport and send electronic components, modules or devices in their original packaging or in other suitable materials, e.g. conductive foam rubber or aluminum foil.
- Only touch components, modules and devices when you are grounded by one of the following methods:
 - Wearing an ESD wrist strap
 - Wearing ESD shoes or ESD grounding straps in ESD areas with conductive flooring
- Only place electronic components, modules or devices on conductive surfaces (table with ESD surface, conductive ESD foam, ESD packaging, ESD transport container).

1.3 Warranty and liability for application examples

The application examples are not binding and do not claim to be complete regarding configuration, equipment or any eventuality which may arise. The application examples do not represent specific customer solutions, but are only intended to provide support for typical tasks. You are responsible for the proper operation of the described products. These application examples do not relieve you of your responsibility for safe handling when using, installing, operating and maintaining the equipment.

1.4 Industrial security

Note

Industrial security

Siemens provides products and solutions with industrial security functions that support the secure operation of plants, systems, machines and networks.

In order to protect plants, systems, machines and networks against cyber threats, it is necessary to implement – and continuously maintain – a holistic, state-of-the-art industrial security concept. Siemens products and solutions only represent one component of such a concept.

The customer is responsible for preventing unauthorized access to its plants, systems, machines and networks. Systems, machines and components should only be connected to the enterprise network or the internet if and to the extent necessary and with appropriate security measures (e.g. use of firewalls and network segmentation) in place.

Additionally, Siemens' guidance on appropriate security measures should be taken into account. For more information about industrial security, please visit:

Industrial security (<http://www.siemens.com/industrialsecurity>).

Siemens' products and solutions undergo continuous development to make them more secure. Siemens strongly recommends to apply product updates as soon as available and to always use the latest product versions. Use of product versions that are no longer supported, and failure to apply latest updates may increase customer's exposure to cyber threats.

To stay informed about product updates, subscribe to the Siemens Industrial Security RSS Feed at:

Industrial security (<http://www.siemens.com/industrialsecurity>).

WARNING

Unsafe operating states resulting from software manipulation

Software manipulations (e.g. viruses, trojans, malware or worms) can cause unsafe operating states in your system that may lead to death, serious injury, and property damage.

- Keep the software up to date.
- Incorporate the automation and drive components into a holistic, state-of-the-art industrial security concept for the installation or machine.
- Make sure that you include all installed products into the holistic industrial security concept.
- Protect files stored on exchangeable storage media from malicious software by with suitable protection measures, e.g. virus scanners.

1.5 Residual risks of power drive systems

When assessing the machine- or system-related risk in accordance with the respective local regulations (e.g., EC Machinery Directive), the machine manufacturer or system installer must take into account the following residual risks emanating from the control and drive components of a drive system:

1. Unintentional movements of driven machine or system components during commissioning, operation, maintenance, and repairs caused by, for example,
 - Hardware and/or software errors in the sensors, control system, actuators, and cables and connections
 - Response times of the control system and of the drive
 - Operation and/or environmental conditions outside the specification
 - Condensation/conductive contamination
 - Parameterization, programming, cabling, and installation errors
 - Use of wireless devices/mobile phones in the immediate vicinity of electronic components
 - External influences/damage
 - X-ray, ionizing radiation and cosmic radiation
2. Unusually high temperatures, including open flames, as well as emissions of light, noise, particles, gases, etc., can occur inside and outside the components under fault conditions caused by, for example:
 - Component failure
 - Software errors
 - Operation and/or environmental conditions outside the specification
 - External influences/damage
3. Hazardous shock voltages caused by, for example:
 - Component failure
 - Influence during electrostatic charging
 - Induction of voltages in moving motors
 - Operation and/or environmental conditions outside the specification
 - Condensation/conductive contamination
 - External influences/damage
4. Electrical, magnetic and electromagnetic fields generated in operation that can pose a risk to people with a pacemaker, implants or metal replacement joints, etc., if they are too close
5. Release of environmental pollutants or emissions as a result of improper operation of the system and/or failure to dispose of components safely and correctly
6. Influence of network-connected communication systems, e.g. ripple-control transmitters or data communication via the network

For more information about the residual risks of the drive system components, see the relevant sections in the technical user documentation.

System overview

2.1 Field of application

SINAMICS is the family of drives from Siemens designed for machine and plant engineering applications. SINAMICS offers solutions for all drive tasks:

- Simple pump and fan applications in the process industry
- Complex single drives in centrifuges, presses, extruders, elevators, as well as conveyor and transport systems
- Drive line-ups in textile, plastic film, and paper machines as well as in rolling mill plants
- High-precision servo drives in the manufacture of wind turbines
- Highly dynamic servo drives for machine tools, as well as packaging and printing machines

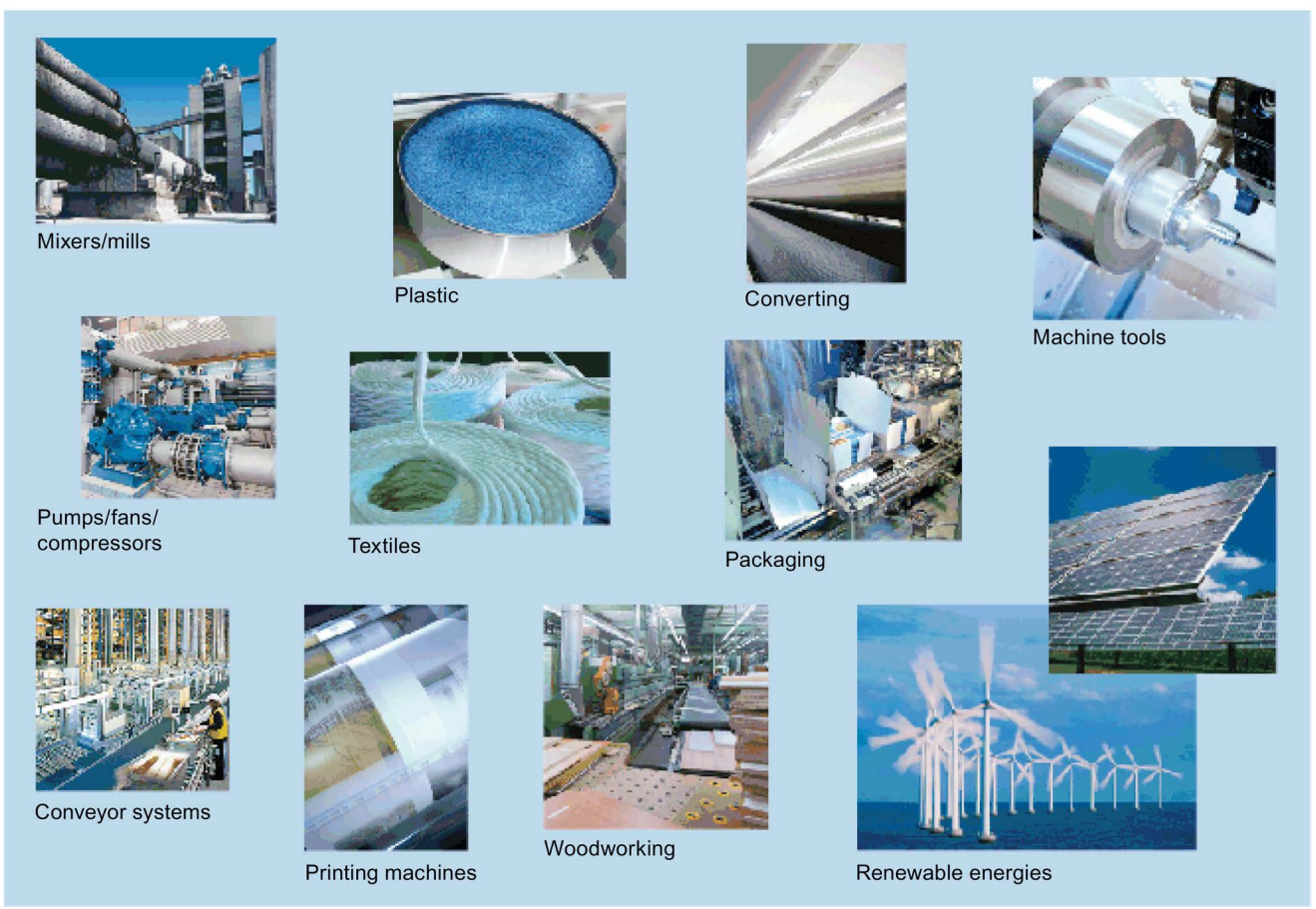

Figure 2-1 SINAMICS applications

Depending on the application, the SINAMICS range offers the ideal variant for any drive task.

- SINAMICS S handles complex drive tasks with synchronous motors and induction motors and fulfills stringent requirements regarding:
 - the dynamic performance and accuracy
 - the integration of extensive technological functions in the drive control system
- SINAMICS G is designed for standard applications with induction motors. These applications have less stringent requirements regarding the dynamic performance of the motor speed.
- SINAMICS V is designed to address applications where basic drive functions are available quickly and at a favorable cost - and which are easy to handle.

2.2 Platform Concept and Totally Integrated Automation

All SINAMICS versions are based on a platform concept. Joint hardware and software components, as well as standardized tools for design, configuration, and commissioning tasks ensure high-level integration across all components. SINAMICS handles a wide variety of drive tasks with no system gaps. The different SINAMICS versions can be easily combined with each other.

Totally Integrated Automation (TIA) with SINAMICS S120

Apart from SIMATIC, SIMOTION and SINUMERIK, SINAMICS is one of the core components of TIA. It is thus possible to parameterize, program and commission all components in the automation system using the STARTER or Startdrive commissioning tool based on a standardized engineering platform and without any system transitions. The system-wide data management functions ensure consistent data and simplify archiving of the entire plant project.

From V14, the Startdrive commissioning tool is an integral element of the TIA platform.

SINAMICS S120 supports communication via PROFINET and PROFIBUS DP.

Communication via PROFINET

This Ethernet-based bus enables control data to be exchanged at high speed via PROFINET IO with IRT or RT and makes SINAMICS S120 a suitable choice for integration in high-performance multi-axis applications. At the same time, PROFINET also uses standard IT mechanisms (TCP/IP) to transport information, e.g. operating and diagnostic data, to higher-level systems. This makes it easy to integrate into an IT corporate network.

Communication via PROFIBUS DP

This bus provides a high-performance, system-wide and integrated communication network which links all automation components of the automation solution:

- HMI (operator control and monitoring)
- Control
- Drives and I/O



Figure 2-2 SINAMICS as part of the Siemens modular automation system

2.3 Introduction

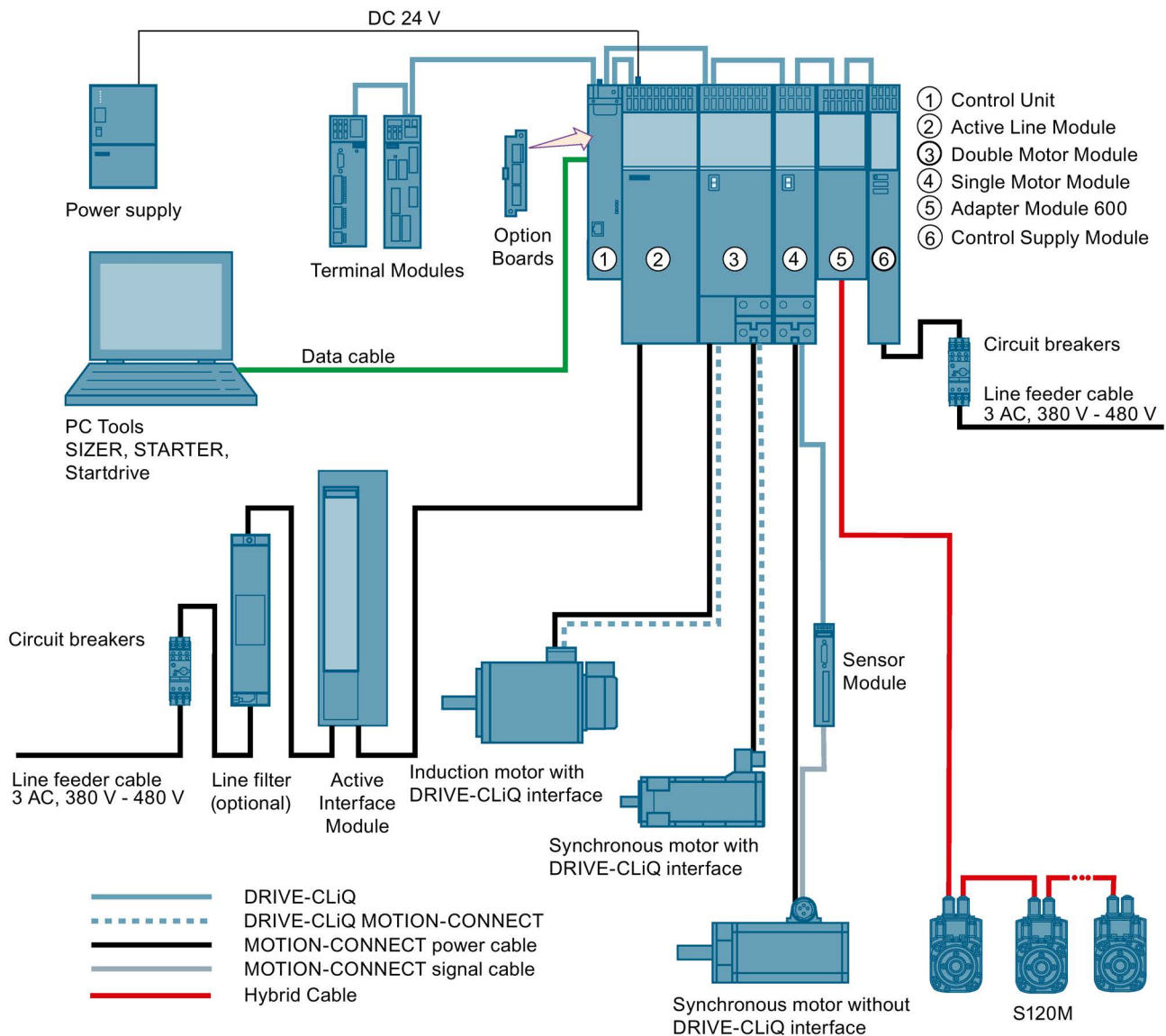

Figure 2-3 SINAMICS S120 system overview

Modular system for sophisticated drive tasks

SINAMICS S120 solves complex drive tasks for a wide range of industrial applications and is, therefore, designed as a modular system. Users can choose from many different harmonized components and functions to create a solution that best meets their requirements. SIZER, a high-performance engineering tool, makes it easier to select and determine the optimum drive configuration.

SINAMICS S120 is supplemented by a wide range of motors. Whether torque, synchronous or induction motors, whether rotating or linear motors, all of these motors are optimally supported by SINAMICS S120.

System architecture with a central Control Unit

On the SINAMICS S120, the drive intelligence is combined with closed-loop control functions into Control Units. These units are capable of controlling drives in the vector, servo and V/f modes. They also perform the speed and torque control functions plus other intelligent drive functions for all axes on the drive. Inter-axis connections can be established within a component and easily configured in the STARTER/Startdrive commissioning tool using a mouse.

Functions for higher efficiency

- Basic functions: Speed control, torque control, positioning functions
- Intelligent starting functions for independent restart after power supply interruption
- BICO technology with interconnection of drive-related I/Os for easy adaptation of the drive system to its operating environment
- Integrated safety functions for rational implementation of safety concepts
- Regulated infeed/regenerative feedback functions for preventing undesirable reactions on the supply, allowing recovery of braking energy and ensuring greater stability against line fluctuations.

DRIVE-CLiQ – the digital interface between SINAMICS components

Most of the SINAMICS S120 components, including the motors and encoders, are connected to each other via the common DRIVE-CLiQ serial interface. The standardized cables and connectors reduce the variety of different parts and cut storage costs. Encoder evaluations for converting standard encoder signals to DRIVE-CLiQ are available for third-party motors or retrofit applications.

Electronic rating plates in all components

An important digital linkage element of the SINAMICS S120 drive system are the electronic type plates integrated in every component. They allow all drive components to be detected automatically via a DRIVE-CLiQ link. As a result, data does not have to be entered manually during commissioning or component replacement – helping to ensure that drives are commissioned more reliably.

The rating plate contains all the relevant technical data about that particular component. For motors, these are the parameters of the electrical equivalent circuit diagram and key values of the integrated motor encoder, for example.

In addition to the technical data, the type plate includes logistical data (manufacturer ID, article number and ID). Since this data can be called up electronically on site or remotely, all the components used in a machine can always be individually identified, which helps simplify servicing.

2.4 SINAMICS S120 components

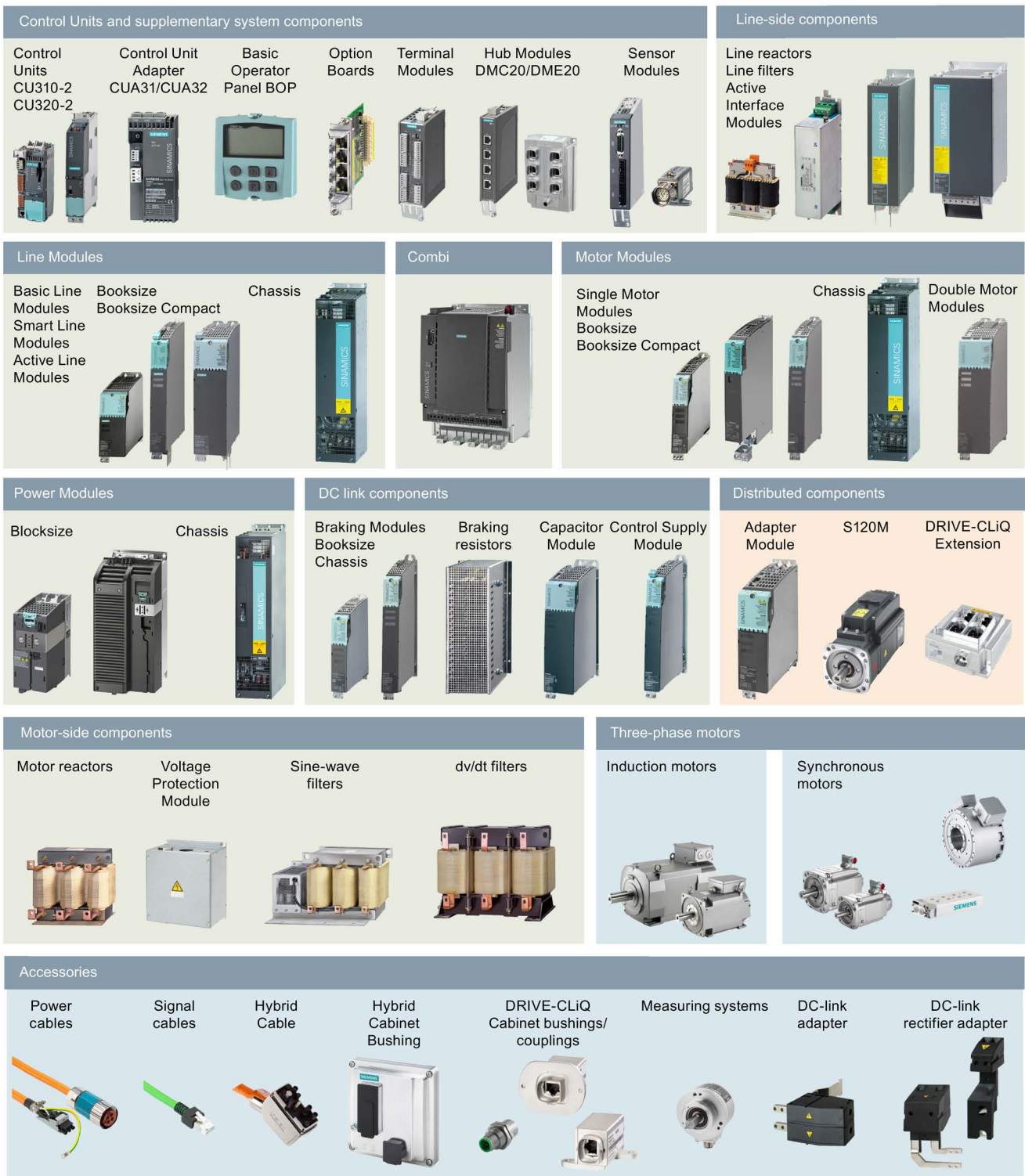

Figure 2-4 Overview of SINAMICS S120 components

System components

- Line-side power components, such as fuses, contactors, reactors, and filters for switching the power supply and meeting EMC requirements.
- Line Modules, which supply power centrally to the DC link
- DC link components (optional), which stabilize the DC link voltage.
- Motor Modules, which act as inverters, receive power from the DC link, and supply the connected motors
- Power components on the motor side, such as reactors and Voltage Protection Modules, which allow output currents and output voltages to be reduced

To carry out the required functions, SINAMICS S120 is equipped with:

- Control Units that process the drive and technological functions across all axes
- Additional system components to expand the functionality and to handle various interfaces for encoders and process signals

SINAMICS S120 components are intended for installation in cabinets. They have the following features and characteristics:

- Easy to handle, simple installation and wiring
- Practical connection system, cable routing in accordance with EMC requirements
- Standardized design, side-by-side mounting

Note

Installation location in the cabinet

As a general rule, SINAMICS S120 components must be mounted vertically in the control cabinet. If components can be mounted with alternative orientations, this is stated in the technical data.

Booksize format

Booksize format units are optimized for multi-axis applications and are mounted adjacent to one another. The connection for the shared voltage-source DC link is an integral feature.

The booksize format offers various cooling options:

- Internal air cooling
- External air cooling
- Cold plate cooling
- Liquid Cooled

Booksize compact format

The booksize compact format combines all benefits of the booksize format and provides the same performance with an even smaller overall height. The booksize compact format is thus particularly well suited for integration into machines with high dynamic requirements and confined installation conditions.

The booksize compact format offers the following cooling options:

- Internal air cooling
- Cold plate cooling

2.4.1 Overview of Line Modules

Line Modules generate a DC voltage from the connected rated voltage that is used to power the Motor Modules.

All Basic Line Modules and Active Line Modules as well as the 16 kW, 36 kW, and 55 kW Smart Line Modules are equipped with DRIVE-CLiQ interfaces for communicating with the Control Unit. The 5 kW and 10 kW Smart Line Modules must be connected with the Control Unit via terminals.

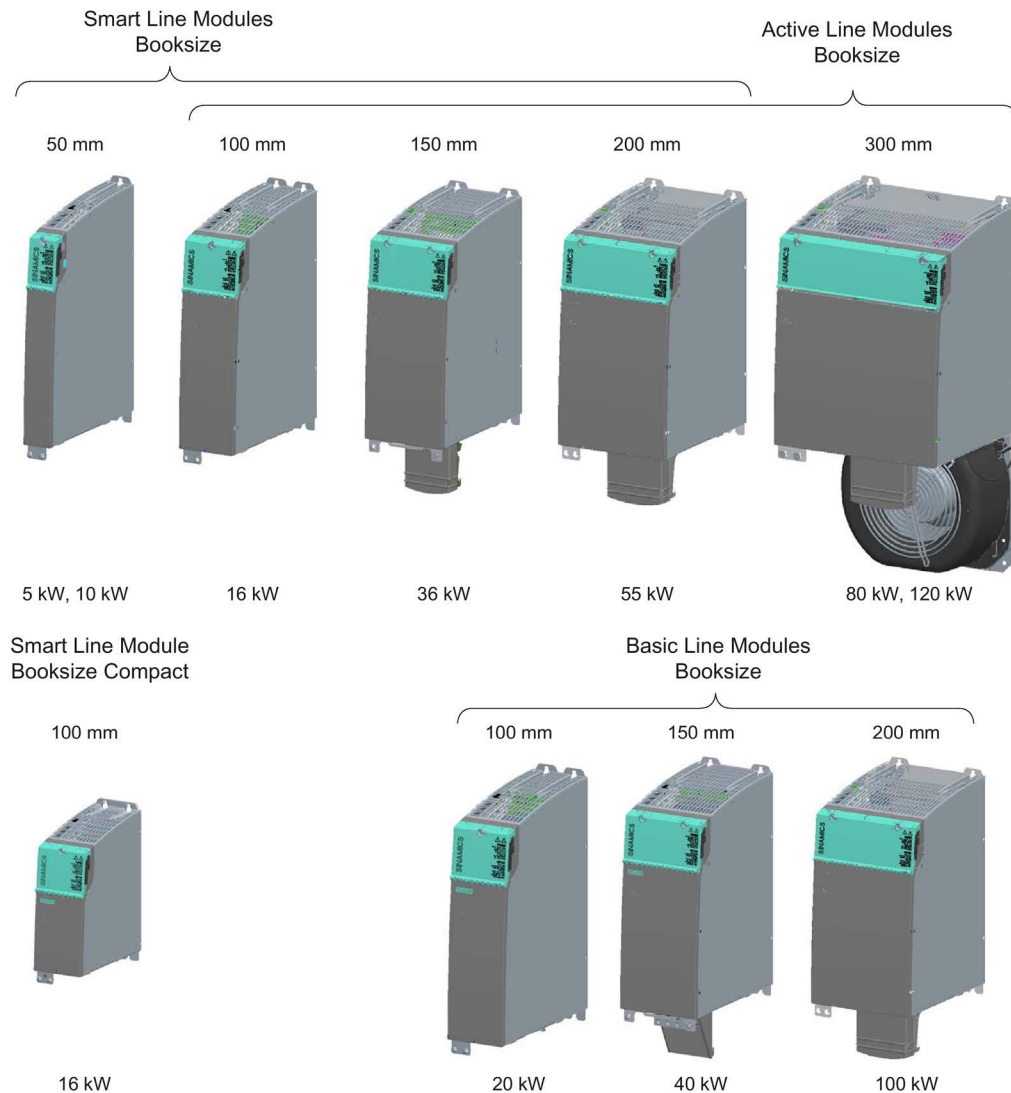

Figure 2-5 Overview of Line Modules

General characteristics of the Line Modules

- Supply voltage, 3 AC 380 V to 480 V $\pm 10\%$ (-15 % <1 min), 47 to 63 Hz
- Suitable for TN, TT, and IT supply systems
- Internal/external air cooling
- Liquid cooling and cold plate cooling
- Short-circuit/ground-fault-proof during the precharge phase
- Integrated DC link and electronics current busbar connection
- LEDs for indicating statuses and for diagnostics

Characteristics of the Active Line Modules

- Regulated DC link voltage
- Regenerative feedback capability
- Sinusoidal line currents
- Electronic rating plate
- DRIVE-CLiQ interface for communication with the Control Unit and/or other components in the drive line-up.
 - Integration in system diagnostics
- For all Active Line Modules with article numbers ending in 3 (6SL...-...3): outgoing circuit for DC link busbar possible on both sides.

Characteristics of the Smart Line Modules

- Unregulated DC link voltage
- Regenerative feedback capability
- Block-type network currents in feedback direction
- For 16 kW to 55 kW Smart Line Modules: outgoing circuit for DC link busbar possible on both sides.

Characteristics of the Basic Line Modules

- Unregulated DC link voltage
- No regenerative feedback capability
- For all Basic Line Modules, an outgoing circuit for DC link busbar is possible on both sides.

2.4.2 Overview of Motor Modules

The Motor Modules in the SINAMICS S system in booksize format are inverters. They make the energy from the connected motors' DC link available at an adjusted voltage and with variable frequency. The control information is generated in the Control Unit and distributed to the individual Motor Modules via DRIVE-CLiQ.

Depending on the type (Single or Double), each Motor Module has one or two DRIVE-CLiQ interfaces for connecting the motor encoder evaluation (Sensor Modules).

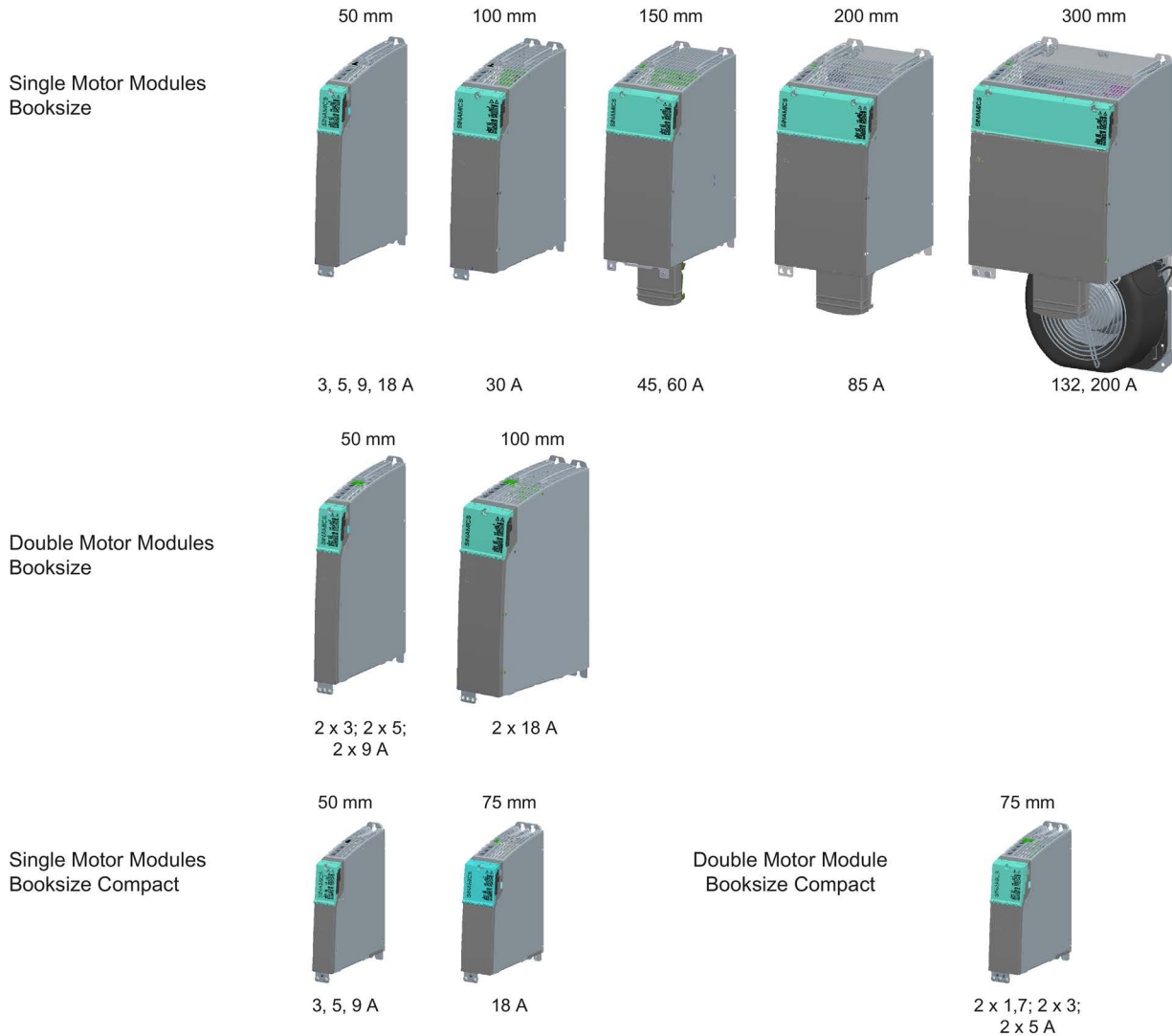

Figure 2-6 Overview of Motor Modules

Characteristics of the Motor Modules:

- Single type from 3 A to 200 A
- Double type from 1.7 A to 18 A
- Internal/external air cooling
- Liquid cooling and cold plate cooling
- Short-circuit/ground-fault-proof
- Integrated DC link and electronics current busbar connection
- Integrated "safety motor braking control"
- Electronic rating plate
- Operating status and error status via LEDs
- DRIVE-CLiQ interface for communication with the Control Unit and/or other components in the drive line-up.
- Integration in system diagnostics

2.5 System data

Unless explicitly specified otherwise, the following technical data is valid for components of the SINAMICS S120 booksize drive system.

Table 2- 1 Electrical data

Line connection voltage	3 AC 380 ... 480 V ±10 % (-15 % < 1 min)
Line frequency	47 ... 63 Hz
Electronics power supply	24 V DC -15/+20% ¹⁾ , safety extra-low voltage (PELV/SELV) (see Chapter 24 V DC supply voltage (Page 671))
Rated short-circuit current (SCCR) according to UL 61800-5-1	100 kA in connection with fuses Class J ²⁾ SCCR in connection with other protection devices, see "Protective Devices for SINAMICS S120 Line Modules Booksize (https://support.industry.siemens.com/cs/de/de/view/109749282)".
Overvoltage category	III according to EN 61800-5-1
Degree of contamination	2 according to EN 61800-5-1, EN 61800-5-2 ³⁾

- 1) When using a motor holding brake, possibly restricted voltage tolerances (24 V ±10 %) must be taken into account.
- 2) For Motor Modules partly 65 kA; refer to the respective technical data for detailed specifications
- 3) The components must be protected against conductive pollution, e.g. by installing them in a control cabinet with degree of protection IP54 according to IEC 60529 or Type 12 according to NEMA 250. If conductive pollution can be excluded at the installation site, a lower degree of cabinet protection is permissible.

Table 2- 2 Modules

Line Modules in the booksize format	
Max. permissible supply voltage	3 AC 480 V
Rated pulse frequency (for Active Line Modules in booksize format only)	8 kHz
Motor Modules in the booksize format	
DC link supply voltage	510 ... 720 V DC
Rated pulse frequency	4 kHz At higher pulse frequencies, the corresponding characteristic for current derating must be taken into consideration

Table 2- 3 Degree of protection / protection class

Degree of protection	IPXXB according to EN 60529, open type according to UL/CSA
Protection class Power circuits Electronic circuits	I, with protective conductor connection PELV/SELV (max. 60 V DC)

Table 2- 4 Environmental conditions

Chemically active substances	
Long-term storage	Class 1C2 according to EN 60721-3-1, in product packaging ¹⁾
Transport	Class 2C2 according to EN 60721-3-2, in transport packaging ²⁾
Operation	Class 3C2 according to EN 60721-3-3
Biological environmental conditions	
Long-term storage	Class 1B1 according to EN 60721-3-1, in product packaging ¹⁾
Transport	Class 2B1 according to EN 60721-3-2, in transport packaging ²⁾
Operation	Class 3B1 according to EN 60721-3-3
Climatic environmental conditions	
Long-term storage	Class 1K4 according to EN 60721-3-1, in product packaging ¹⁾ Temperature: -25 ... +55 °C
Transport	Class 2K4 according to EN 60721-3-2, in transport packaging ²⁾ Temperature: -40 ... +70 °C
Operation	Class 3K3 according to EN 60721-3-3 with increased ruggedness with respect to relative humidity Temperature: 0 ... +40 °C without derating > 40 ... +55 °C with reduction of the output current by 2.67 % pro °C Relative humidity: 5 ... 95 % no condensation (better than Class 3K3) Oil mist, salt mist, ice formation, condensation, dripping water, spraying water, splashing water and water jets are not permitted
Mechanical environmental conditions	
Long-term storage	Class 1M2 according to EN 60721-3-1, in product packaging ¹⁾
Transport	Class 2M3 according to EN 60721-3-2, in transport packaging ²⁾

2.5 System data

Operation Vibration test in operation	Class 3M1 according to EN 60721-3-3 According to IEC 60068-2-6 test Fc (sinusoidal)
Shock test in operation	<ul style="list-style-type: none"> • 10 ... 57 Hz: 0.075 mm deflection amplitude • 57 ... 150 Hz: 1 g acceleration amplitude • 10 frequency cycles per axis
Installation altitude	
Operation	<p>0 ... 1000 m above sea level without derating</p> <p>> 1000 ... 4000 m</p> <ul style="list-style-type: none"> • Reduction of the output current by 10 % per 1000 meters, or • Reduction in the ambient temperature by 5 °C per 1000 meters <p>> 2000 ... 4000 m</p> <ul style="list-style-type: none"> • Operation on line supply systems with grounded neutral point, or • Operation on an isolating transformer with secondary grounded neutral point

- 1) Product packaging (storage packaging) is individual packaging for storage - and does not satisfy the requirements for transport. As a consequence, product packaging is therefore not suitable for shipping.
- 2) Transport packaging is either packaging that is directly suitable for transport - or secondary packaging, which together with the product packaging, satisfies the requirements for transport.

Table 2- 5 Certificates

Declarations of Conformity	CE
Approvals ¹⁾	<p>cULus</p> <ul style="list-style-type: none"> • UL file numbers for Booksize power units: E192450, Vol. 5 and Vol. 7 <p>cURus</p>

¹⁾ Possible deviations are specified for the corresponding component.

Line connection and line-side power components

3.1 Introduction

The following components are used to connect a SINAMICS S120 drive line-up in booksize format to the line supply:

- Disconnecter unit
- Overcurrent protection device
- Line contactor (optional)
- Line filter (optional)
- Line reactor or also Active Interface Module for Active Line Module (always required)

The following line filter and line reactor variants are available:

- Line filter variants:
 - Basic Line Filter for Active Line Modules with line reactor
 - Basic Line Filter for Active Line Modules with Active Interface Module
 - Basic Line Filter for Basic Line Modules
 - Basic Line Filter for Smart Line Modules
- Line reactor variants:
 - Line reactors for Active Line Modules
 - Line reactors for Smart Line Modules
 - Line reactors for Basic Line Modules

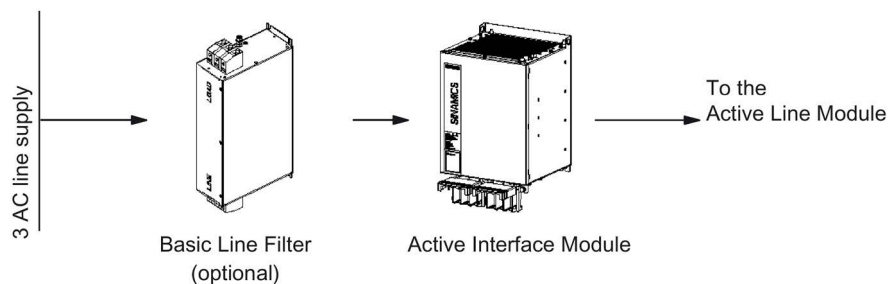

Figure 3-1 Overview diagram, line connection with Active Interface Module

3.2 Information on the disconnecter unit

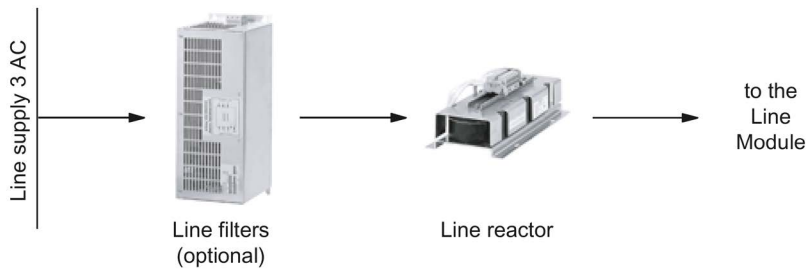

Figure 3-2 Overview diagram, line connection with line filter and line reactor

3.2 Information on the disconnecter unit

Disconnecter units for Active Line Modules, Basic Line Modules, and Smart Line Modules

A line disconnecter is required for disconnecting the drive line-up from the supply system. This must be selected in compliance with local regulations.

NOTICE

Damage to the drive electronics when switching the line disconnection equipment under load

When switching the line disconnecter unit under load, then the contacts will be subject to premature wear. This can cause the line disconnection equipment to malfunction, with subsequent damage to the drive electronics.

- Use a leading opening auxiliary contact or use a Voltage Sensing Module (VSM10).
- If this is not possible, then avoid switching the line disconnection equipment under load.

The accessories required for the disconnecter unit must be selected from the manufacturer catalogs.

3.3 Overcurrent protection using fuses and circuit breakers

You must use line fuses or circuit breakers for overcurrent protection. The following protective elements can result in reductions.

Detailed specifications regarding protective devices can be obtained in the product information "Protective Devices for Line Modules Booksize (<https://support.industry.siemens.com/cs/de/de/view/109749282>)".



WARNING

Electric shock or fire due to overcurrent protective equipment that trips too late or not at all

Overcurrent protective equipment that trips too late or not at all can cause electric shock or fire.

- In the case of a conductor-conductor or conductor-ground short-circuit, ensure that the short-circuit current at the point where the converter is connected to the line supply corresponds as a minimum to the requirements of the protective equipment used.
- You must additionally use a residual-current protective device (RCD) if, for a conductor-ground short circuit, the required short-circuit current is not reached. The required short-circuit current can be too low, especially for TT line supply systems.
- The short-circuit current must not exceed the SCCR of the converter and the breaking capacity of the protective equipment.

3.4 Line supply connection via residual-current devices

Selectively tripping, AC/DC-sensitive residual-current devices (type B) can be used in addition to the overcurrent protection devices.

Residual-current devices have to be installed if the power supply conditions in terms of short-circuit power and loop impedance at the infeed point are not such that the installed overcurrent protection devices will trip within the prescribed period if a fault occurs.



WARNING

Electric shock or fire when using unsuitable residual current protective devices

The inverter can cause a current to flow in the protective conductor.

This current can cause the residual current device (RCD) or residual current monitoring (RCM) to incorrectly trip (nuisance trip). In the case of a fault (ground fault), the fault current can contain a DC component, which prevents the RCD/RCM from tripping, with the risk of subsequent electric shock or fire.

- Use the protection and monitoring devices recommended in the documentation.

3.4.1 Residual current protective devices (RCD)

Residual current protective devices (RCD) must be installed if the loop impedance is too great at the line infeed point to ensure triggering of the installed overload protective devices within the prescribed time in the event of a short circuit conductor-ground.

Note

Operation on residual current protective devices is currently only possible with Line Modules up to and including 36 kW.

Conditions for using residual current protective devices

- Super-resistant (short time-delayed) universal current-sensitive RCDs, type B
- Rated residual current 300 mA
- Separate RCD for each Line Module
- Ensure that the loop impedance is maintained corresponding to local installation regulations.
- Check the total length of the shielded power cables (motor cables incl. line supply conductors from line filters to the connecting terminals of the Line Module) in the drive lineup. The total length must be less than 350 m.
- Only operate the system with the recommended line filters.
- If you connect residual current devices in series, they must all have the same characteristics.
- Ensure that the switching elements (disconnecter unit, contactors) for connecting and disconnecting the drive system have a delay time of max. 35 ms between the closing/opening of the individual main contacts.

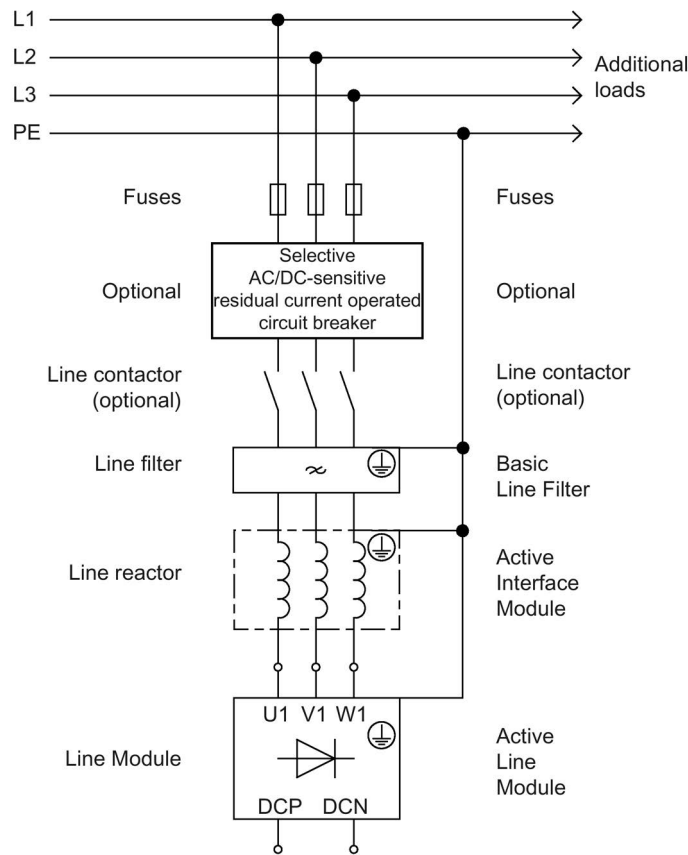

Figure 3-3 Connection of a residual-current protective device

Recommendation

SIEMENS selectively switching universal current-sensitive residual current protective devices according to EN 61009-1 of the 5SM series, e.g. 5SM3646-5 or 5SM3646-5+5SW3300 with an auxiliary disconnector (1 NC contact / 1 NO contact) for a rated current of 63 A and a rated fault current of 0.3 A (see "Siemens Industry Mall (<https://mall.industry.siemens.com/goos/WelcomePage.aspx?regionUrl=/de&language=en>)").

Note

AC or pulse-sensitive RCCBs are not suitable.

3.4.2 Modular residual current protective devices (MRCD)

Used in conjunction with appropriate molded-case circuit breakers, modular residual current devices (MRCD) provide fire and system protection even at high levels of grounding resistance (in TT systems, for example). When operating on TT systems for infeed powers exceeding 55 kW, and with systems that extend across a large area, residual current protection devices must be installed in addition to the molded-case circuit breakers.



WARNING

Fire and shutdown of the plant with the occurrence of residual currents

Residual currents in the power supply that are not detected can cause fires and failures in the entire system.

- Always install modular residual current protective devices in conjunction with suitable molded-case circuit breakers.

Conditions when using modular residual current protective devices:

- Use only AC/DC-sensitive MRCD type B devices with delayed tripping that guarantee reliable tripping even for smoothed DC residual currents.
- Connect parts of the drive system (power drive system) and the machine that can be touched to the system's protective conductor.
- Do **not** route the protective conductor through the measuring current transformer, as this would cancel its protection function.

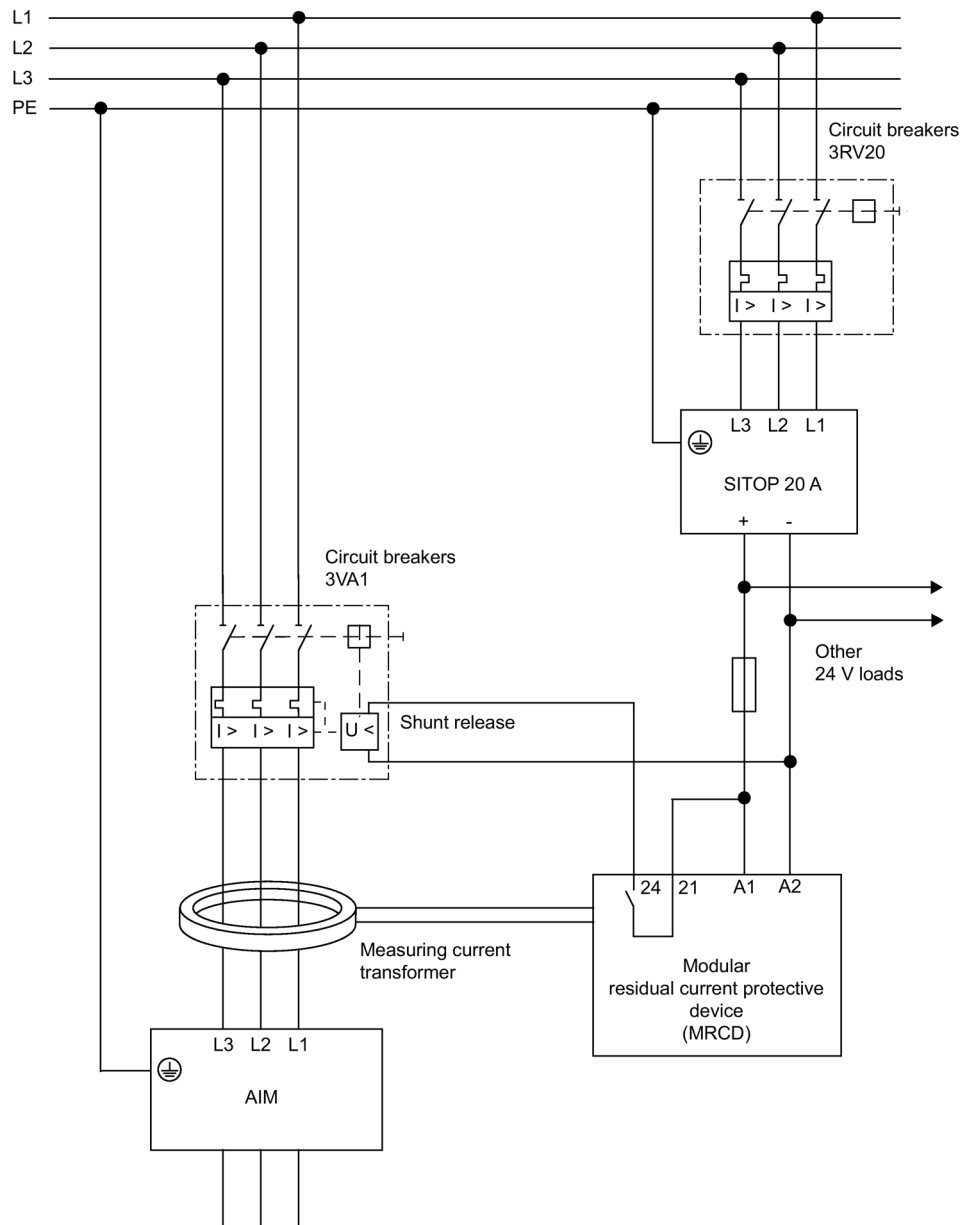

Figure 3-4 Connection of a modular residual current protective device (MRCD)

Recommendation

The subsequently listed products are recommended:

- Modular residual current protective device (MRCD) type B: 5SV8111-4KK, Siemens
- Current transformer: 5SV870.-2K., Siemens
- Circuit breaker: 3VA1....., Siemens
- Shunt release: 3VA9988-0BL30, Siemens

3.5 Line contactors

The characteristic values in the technical data apply when the line contactor is selected. The cables and conductors to be connected must be dimensioned in compliance with local installation regulations.

NOTICE
Damage to the drive electronics when switching the line contactor under load
When switching the line contactor (type according to the recommended selection) under load, then the contacts will be subject to premature wear. This can cause the contactor to malfunction, with subsequent damage to the drive electronics.
<ul style="list-style-type: none">• Use a leading opening auxiliary contact or use a Voltage Sensing Module (VSM10).• If this is not possible, then avoid switching the line contactor under load.

Note

If you are using a VSM10 Voltage Sensing Module, the leading opening contact can be omitted.

Note

To limit the switching overvoltage, the contactor coil must be connected to a surge suppression device (e.g. free-wheeling diode or varistor).

When the digital output is used to control the line contactor, its switching capacity must be taken into account.

3.6 Line filters

3.6.1 Safety instructions for line filters



WARNING

Electric shock due to residual charges in power components

Because of the capacitors, a hazardous voltage is present for up to 5 minutes after the power supply has been switched off.

Contact with live parts can result in death or serious injury.

- Wait for 5 minutes before you check that the unit really is in a no voltage condition and start work.



WARNING

High leakage currents when the protective conductor in the line feeder cable is interrupted

The drive components conduct a high leakage current via the protective conductor. Touching conductive parts when the protective conductor is interrupted can result in death or serious injury.

- Carefully comply with the applicable regulations for dimensioning the protective conductor (see Chapter "Protective connection and equipotential bonding (Page 714)").



CAUTION

Burns due to high surface temperatures

The surface of the components can reach high temperatures during operation. You can get seriously burnt when touching the surface.

- Do not touch the component.

NOTICE

Line filter damage by connecting to impermissible line supply

The line filters are only suitable for direct connection to line supplies with grounded neutral point. Connecting the line filter to another network will damage the line filter.

- Only connect the line filter to a line supply with grounded neutral point.

3.6 Line filters

NOTICE
Line filter damage due to interchanged connections
The line filter will be damaged if the input and output connections are interchanged.
<ul style="list-style-type: none">• Connect the incoming line supply cable to LINE L1, L2, L3.• Connect the outgoing line to line reactor at LOAD L1', L2', L3' (U, V, W).

NOTICE
Damage to the system caused by a line filter that is not permissible
A line filter that is not permissible can cause system damage.
<ul style="list-style-type: none">• Only use the line filter with the components specified in Chapter "Combination options of Line Modules with line reactors and line filters (Page 120)".

NOTICE
Destruction or damage of components by incorrectly connecting the line filter
When incorrectly connecting the line filter, components can be destroyed or damaged.
<ul style="list-style-type: none">• Connect the line filter in accordance with the instructions in the technical documentation.• Do not connect any additional loads downstream of the line filter.

Note

Disconnect the line filter for a high-voltage test

If a high-voltage test is conducted with alternating voltage in the system, the existing line filters must be disconnected in order to obtain accurate measurements.

Note

Length of connecting cables

The connecting cables between the line filter via the Active Interface Module and the line reactor to the Line Module must be kept as short as possible (max. 10 m).

Use shielded connection cables. whose cable shields are attached at both ends.

Shielding can only be omitted if the following conditions are met:

- The cables do not exceed 1 m in length.
- The cables are laid flush with the rear metal wall of the control cabinet.
- The cables are laid in a way that keeps them physically separate from signal cables.

All signal cables must be laid separately from the line filter and from unshielded connection cables of the filter with a minimum clearance of 200 mm.

3.6.2 Overview of line filters

In conjunction with line reactors and a consistent EMC-compliant system configuration, line filters limit the conducted electromagnetic emissions generated by the Line Modules to the limit values according to EN 61800-3. A separate line filter as listed in the subsequent table must be used for the SINAMICS S120 drive line-up.

NOTICE

Damage caused by connecting several loads to the same line infeed point

Damage can be caused if several loads are connected to the same line infeed point.

- Provide interference suppression for the other loads using appropriate line filters. To prevent mutual interference, it is not permissible that this line filter is equipped with capacitors with respect to ground. A series B84144A*R120 filter (EPCOS) is recommended.

NOTICE

Damage caused by using third party filters

According to product standard EN 61800-3, RFI suppression commensurate with the relevant rated conditions must be provided and is a legal requirement in the EU (EMC Directive). Line filters and line reactors are required in order to comply with this standard. The use of filters of other makes can lead to limit value violations, resonances, overvoltage, and irreparable damage to motors or other equipment.

- The machine manufacturer must provide verification that the machine equipped with the drive products and the installed suppression elements, e.g. line filters, is EMC-compliant before the machines are placed in the market.

Line filter ranges that are coordinated with the different power stages are available for the SINAMICS S120 drive system.

The line filter versions listed below are available for use with Line Modules.

Table 3- 1 Overview of line filters

Line filter	Article No.
Basic Line Filter for Active Line Modules with line reactor	
16 kW	6SL3000-0BE21-6DA.
36 kW	6SL3000-0BE23-6DA1
55 kW	6SL3000-0BE25-5DA.
Basic Line Filter for Active Line Modules with Active Interface Modules	
16 kW	6SL3000-0BE21-6DA.
36 kW	6SL3000-0BE23-6DA1
55 kW	6SL3000-0BE25-5DA.
80 kW	6SL3000-0BE28-0DA.
120 kW	6SL3000-0BE31-2DA.

3.6 Line filters

Line filter	Article No.
Basic Line Filter for Basic Line Modules	
20 kW	6SL3000-0BE21-6DA.
40 kW	6SL3000-0BE23-6DA1
100 kW	6SL3000-0BE31-2DA.
Basic Line Filter for Smart Line Modules	
5 kW	6SL3000-0HE15-0AA.
10 kW	6SL3000-0HE21-0AA.
16 kW	6SL3000-0BE21-6DA.
36 kW	6SL3000-0BE23-6DA1
55 kW	6SL3000-0BE25-5DA.

3.6.3 Basic Line Filters for Active Line Modules

3.6.3.1 Description

Basic Line Filters for Active Line Modules are designed to attenuate conducted interference emissions in accordance with the specifications contained in the relevant EMC directive. They are mainly effective in the frequency range from 150 kHz to 30 MHz; this is the range relevant to ensure compliance with the appropriate standard.

Basic Line Filters can be used in conjunction with a line reactor for 16 kW, 36 kW, and 55 kW Active Line Modules or with an Active Interface Module for 16 kW, 36 kW, 55 kW, 80 kW, and 120 kW Active Line Modules. Data regarding the radio interference voltage categories and maximum total cable lengths that can be achieved¹⁾ see Chapter Combination options, Line Modules with line reactors and line filters (Page 120).

¹⁾ Maximum total cable length = Σ motor cables, line feeder cable from line filter to Line Module

Note

Use of unshielded cables for short distances

Shielded cables should always be routed from the line filter via the Active Interface Module to the Active Line Module. Because the bending radiuses cannot be maintained for short distances, unshielded cables can also be used for cable lengths less than 1 m.

The Basic Line Filters can be used in accordance with the following general conditions for ensuring CE conformity with regard to cable-borne interference:

- The machine/system must only be used in industrial line supplies
- Only connect the Basic Line Filters to TN systems; otherwise an isolating transformer will be required
- Number of axes ≤ 12 when using a Basic Line Filter with an Active Line Module and a line reactor

3.6.3.2 Interface description

Overview

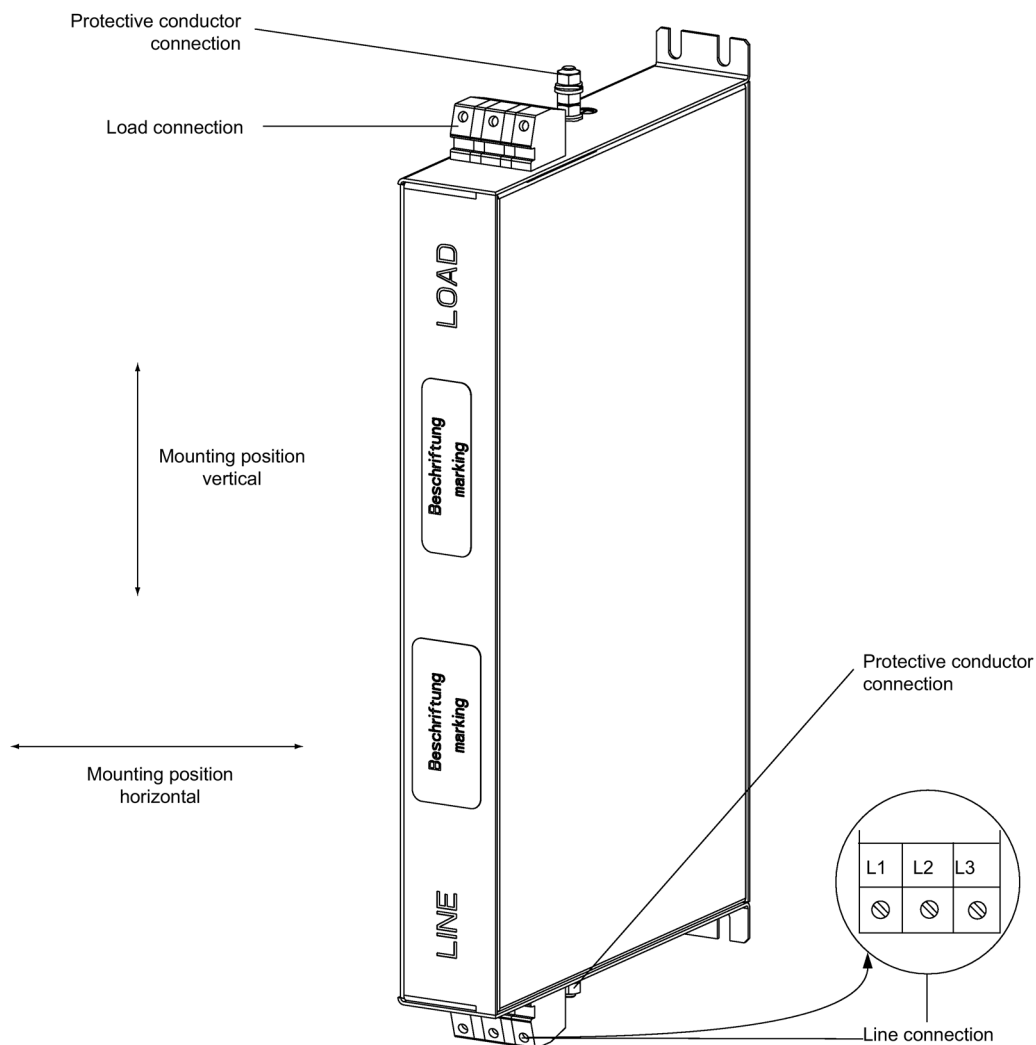

Figure 3-5 Interface overview, Basic Line Filter for Active Line Modules (example: 16 kW)

When connecting the protective conductor, either the upper or the lower screw can be used. One of the screws remains unused. "Looping-through" the protective connection to the line reactor is not permissible.

3.6 Line filters

Line/load connection

Table 3-2 Line and load connection, Basic Line Filter for Active Line Modules

6SL3000-	0BE21-6DA.	0BE23-6DA1	0BE25-5DA.	0BE28-0DA.	0BE31-2DA.
Rated power [kW]	16	36	55	80	120
Line supply connection L1, L2, L3	Screw terminals 10 mm ² (AWG 8) , 3-pole 1.5 ... 1.8 Nm (15.9 lbf in)	Screw terminals 35 mm ² (AWG 2) , 3-pole 3.2 ... 3.7 Nm (32.7 lbf in)	Screw terminals 50 mm ² (AWG 1) , 3-pole 6 ... 8 Nm (70.1 lbf in)	Screw terminals 95 mm ² (AWG 3/0), 3-pole 15 ... 20 Nm (177 lbf in)	
Load connection L1', L2', L3',					
Protective conductor connection ¹⁾	Terminal stud M6 / 6 Nm (53.1 lbf in)		Terminal stud M8 / 8 Nm (70.1 lbf in)	Terminal studs M10 / 10 Nm	

¹⁾ For ring cable lugs without insulation (Page 710)

3.6.3.3 Dimension drawings

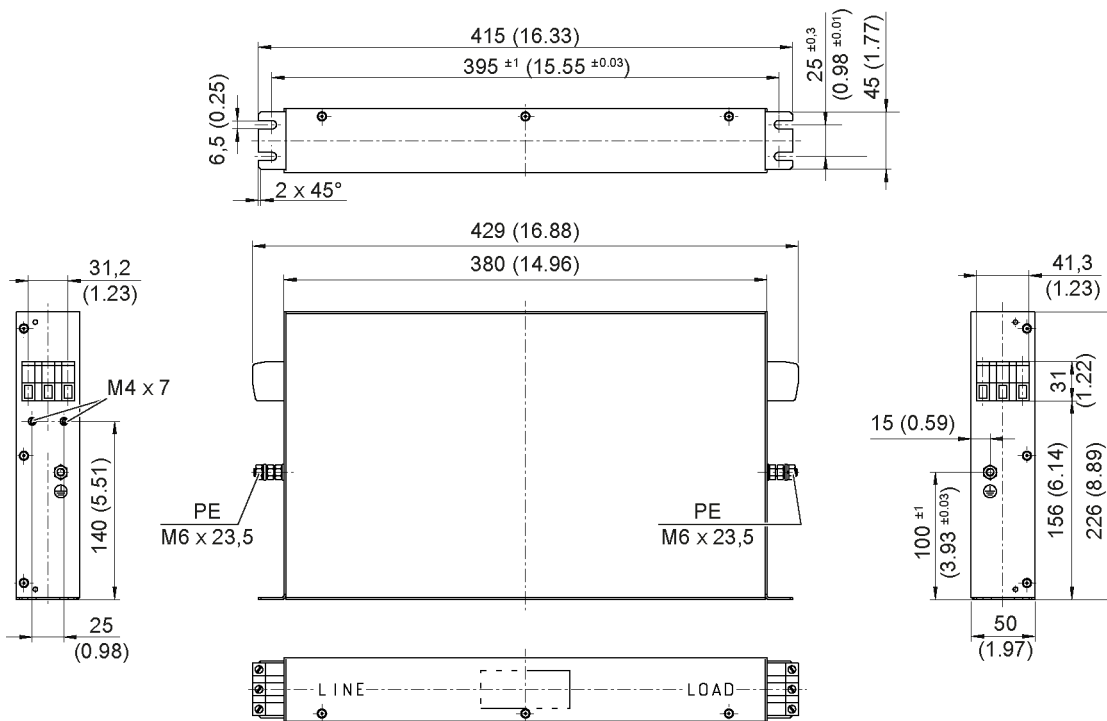

Figure 3-6 Dimension drawing of the Basic Line Filter for Active Line Modules 16 kW, all data in mm and (inches)

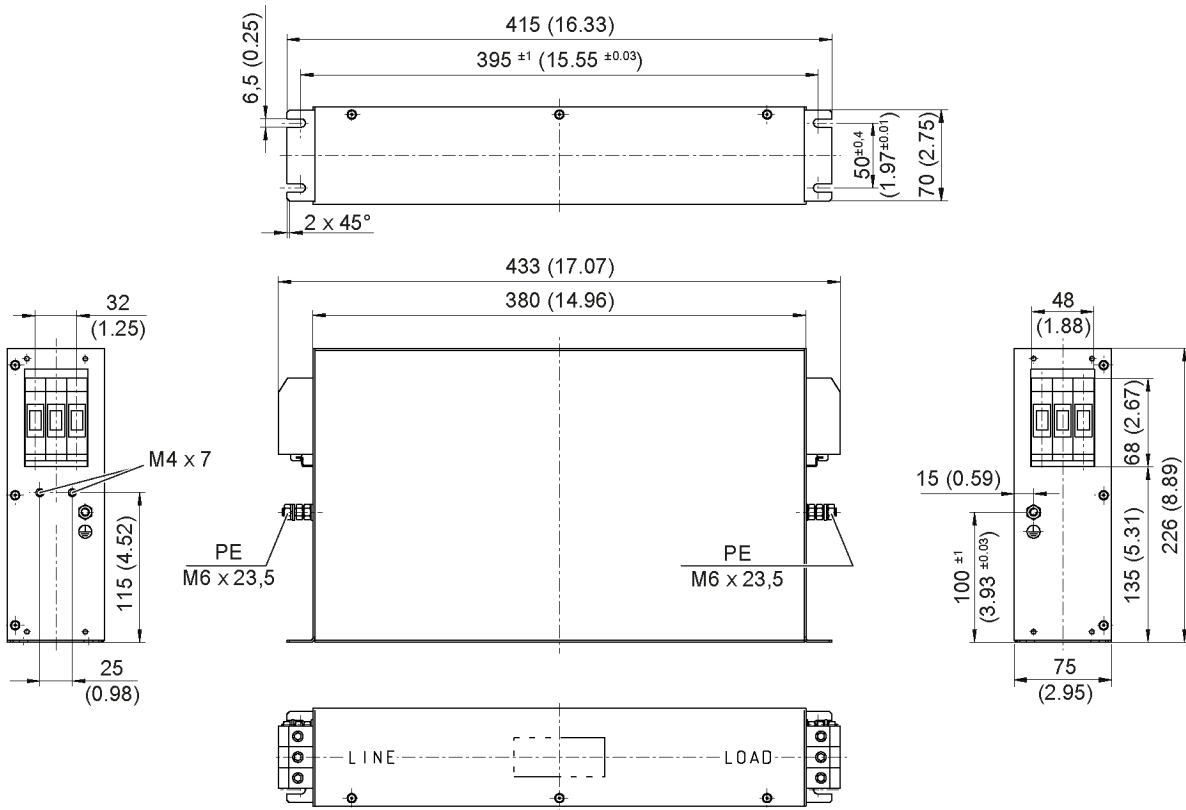

Figure 3-7 Dimension drawing of Basic Line Filter for Active Line Modules 36 kW, all data in mm and (inches)

3.6 Line filters

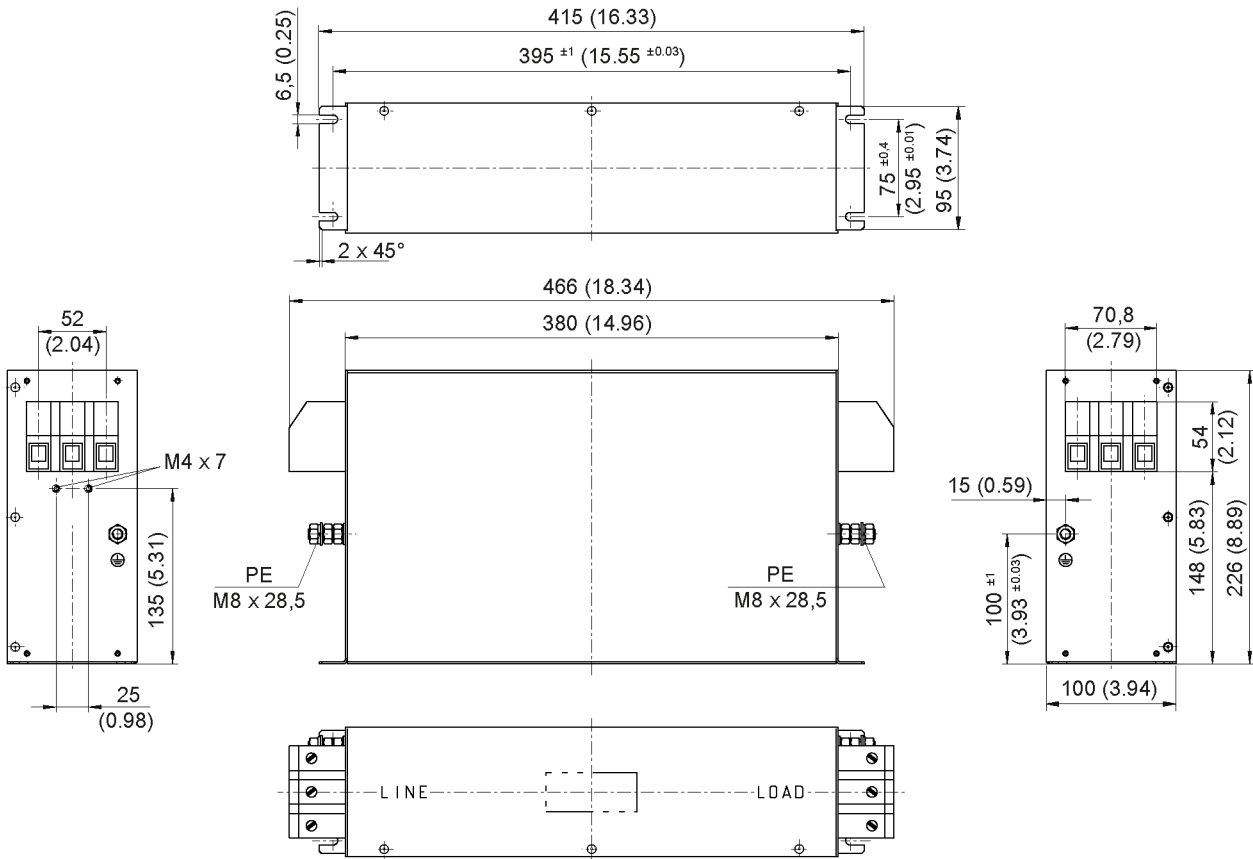

Figure 3-8 Dimension drawing of Basic Line Filter for Active Line Modules 55 kW, all data in mm and (inches)

3.6.4 Basic Line Filter for Basic Line Modules

3.6.4.1 Description

Basic Line Filters for Basic Line Modules are designed to attenuate conducted interference emissions in accordance with the specifications contained in the relevant EMC legislation. They are mainly effective in the frequency range from 150 kHz to 30 MHz; this is the range relevant to ensure compliance with the appropriate standard.

The machine manufacturer must certify that the machine to be launched on the market is in accordance with the EC EMC Directive.

Basic Line Filters for Basic Line Modules can be used in conjunction with the associated line reactors.

Data regarding the radio interference voltage categories and maximum total cable lengths that can be achieved¹⁾ see Chapter Combination options, Line Modules with line reactors and line filters (Page 120).

Basic Line Filters are only suitable for direct use on TN systems. An isolating transformer is required for other power systems.

¹⁾ Maximum total cable length = Σ motor cables, line supply conductor from line filter to Line Module

3.6.4.2 Interface description

Overview

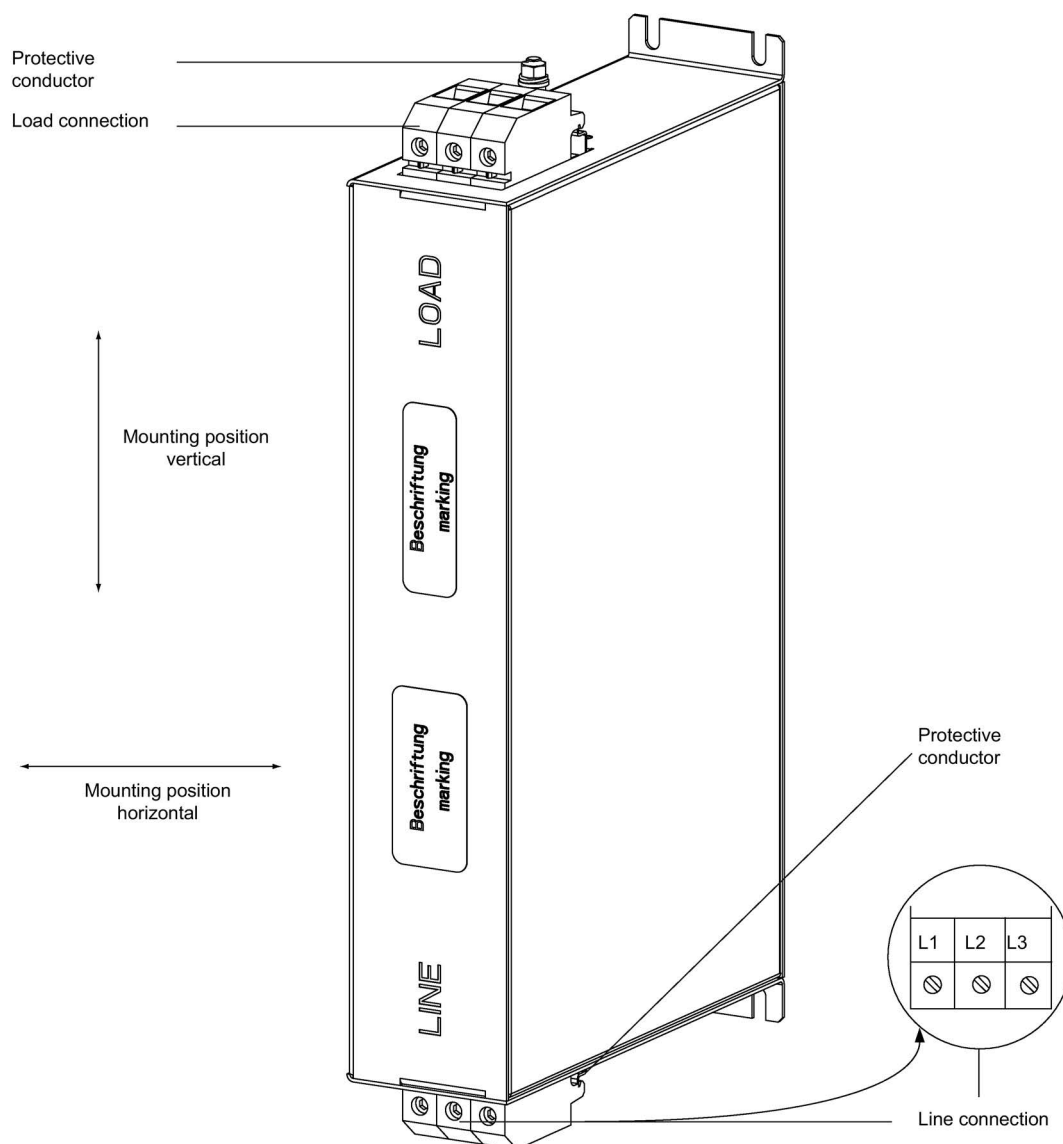

Figure 3-10 Interface overview, Basic Line Filter for Basic Line Modules (example: 40 kW)

When connecting the protective conductor, either the upper or the lower screw can be used. One of the screws remains unused. "Looping-through" the protective connection to the line reactor is not permissible.

3.6 Line filters

Line/load connection

Table 3- 4 Line and load connection, Basic Line Filter for Basic Line Modules

6SL3000-	0BE21-6DA.	0BE23-6DA1	0BE31-2DA.
Rated power [kW]	20	40	100
Line supply connection L1, L2, L3	Screw terminals 10 mm ² (AWG 8), 3-pole 1.5 ... 1.8 Nm (15.9 lbf in)	Screw terminals 35 mm ² (AWG 2), 3-pole 3.2 ... 3.7 Nm (32.7 lbf in)	Screw terminals 95 mm ² (AWG 3/0), 3-pole 15 ... 20 Nm (177 lbf in)
Load connection L1', L2', L3'			
Protective conductor connection ¹⁾	Terminal stud M6 / 6 Nm (53.1 lbf in)	Terminal stud M6 / 6 Nm (53.1 lbf in)	Terminal stud M10 / 10 Nm (88.5 lbf in)

¹⁾ For ring cable lugs without insulation (Page 710)

3.6.4.3 Dimension drawings

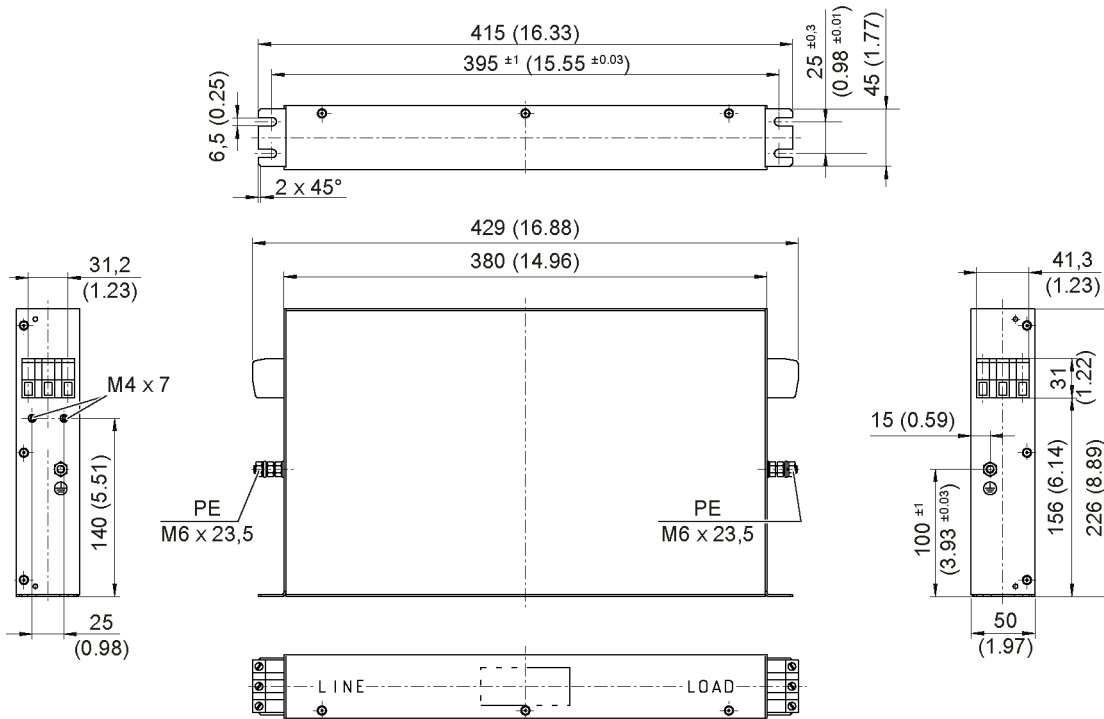

Figure 3-11 Dimension drawing of Basic Line Filter for Basic Line Modules 20 kW, all data in mm and (inches)

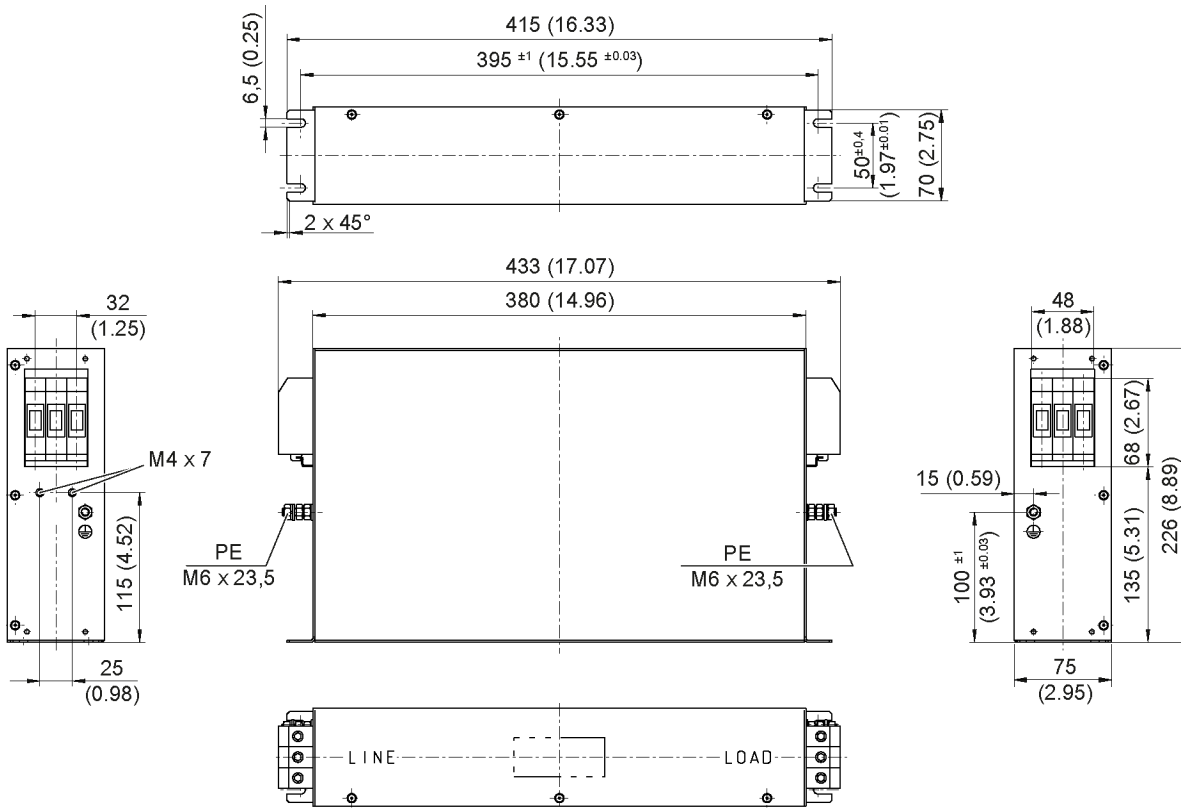

Figure 3-12 Dimension drawing of Basic Line Filter for Basic Line Modules 40 kW, all data in mm and (inches)

3.6 Line filters

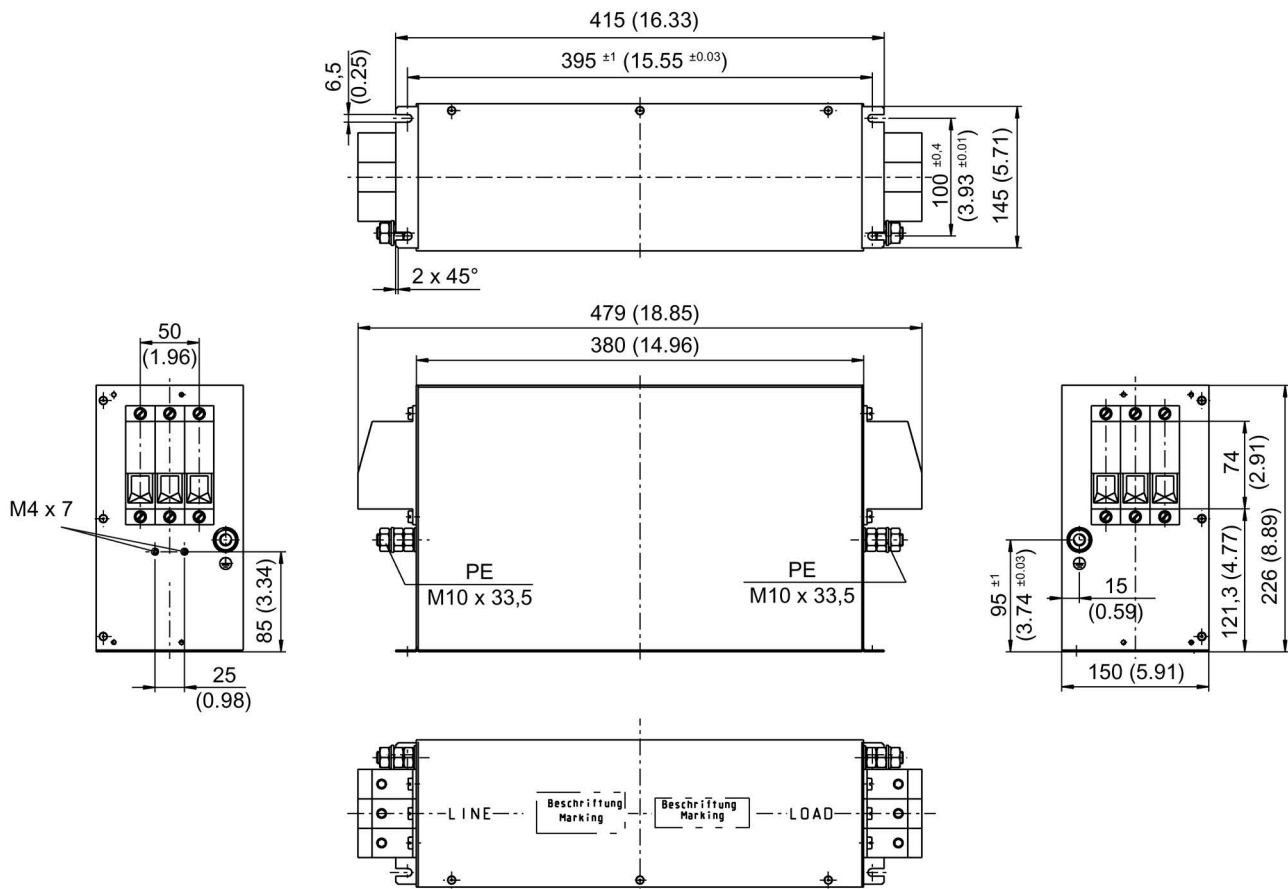

Figure 3-13 Dimension drawing of Basic Line Filter for Basic Line Modules 100 kW, all data in mm and (inches)

3.6.4.4 Technical specifications

Table 3-5 Technical data for Basic Line Filter for Basic Line Modules

	6SL3000-	0BE21-6DA.	0BE23-6DA1	0BE31-2DA.
Rated power	kW	20	40	100
Supply voltage: Line voltage Line frequency	V _{AC} Hz	3 AC 380 -10 % (-15 % < 1 min) ... 3 AC 480 +10 % 47 ... 63 Hz		
Rated current	A _{AC}	36	74	192
Power loss (see power loss tables (Page 734))	W	16	26	43
Weight	kg	5	7.5	18.5
Mounting position		Any		

3.6.5 Basic Line Filter for Smart Line Modules

3.6.5.1 Description

Basic Line Filters for Smart Line Modules are designed to attenuate conducted interference emissions in accordance with the specifications contained in the relevant EMC legislation. They are mainly effective in the frequency range from 150 kHz to 30 MHz; this is the range relevant to ensure compliance with the appropriate standard.

Basic Line Filters for Smart Line Modules can be used in conjunction with the associated line reactors.

Data regarding the radio interference voltage categories and maximum total cable lengths that can be achieved¹⁾ see Chapter Combination options, Line Modules with line reactors and line filters (Page 120).

Basic Line Filters are only suitable for direct connection to TN systems. An isolating transformer is required for other power systems.

¹⁾ Maximum total cable length = Σ motor cables, line supply conductor from line filter to Line Module

3.6.5.2 Interface description

Overview

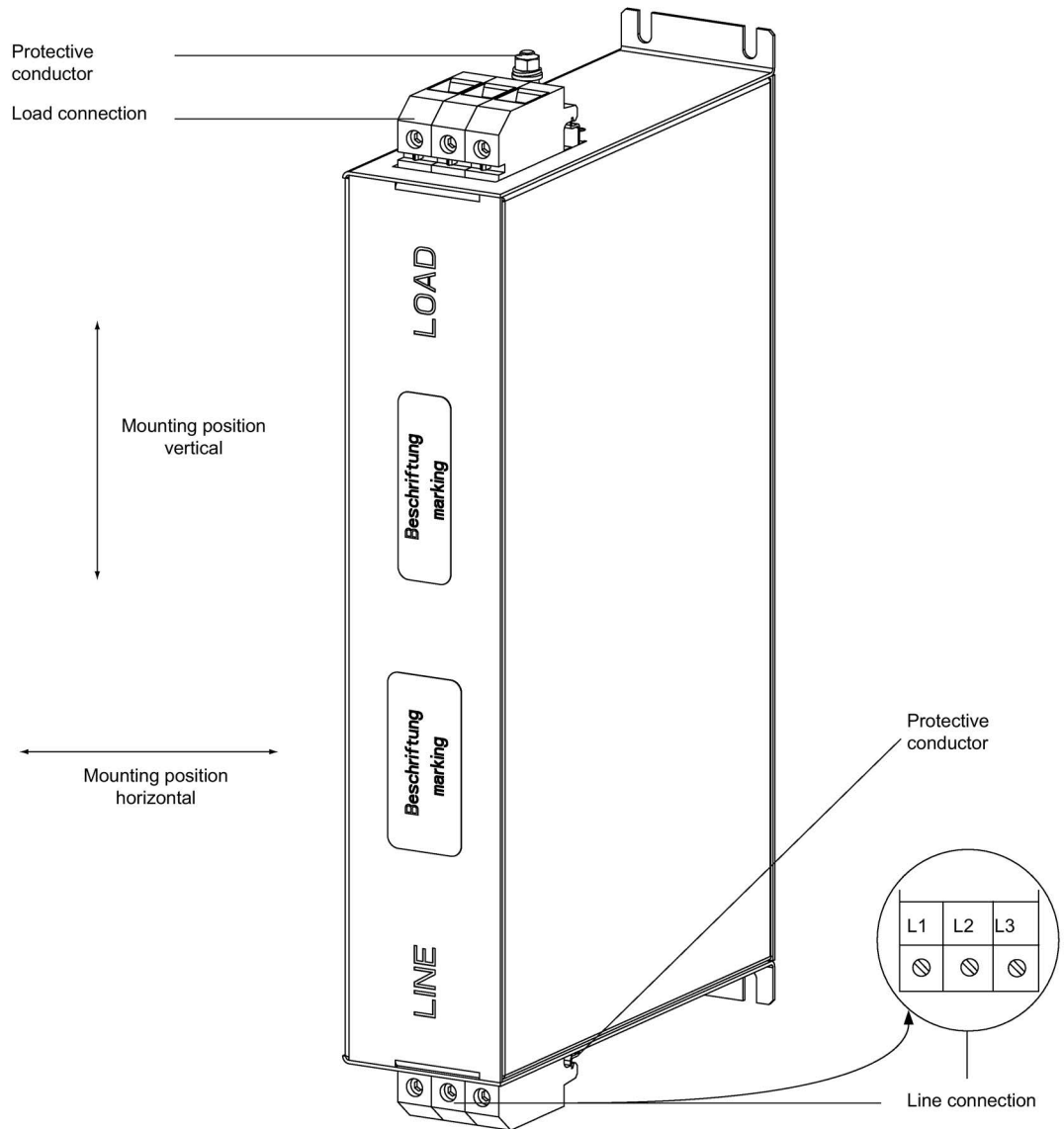

Figure 3-14 Interface overview, Basic Line Filter for Smart Line Modules (example: 36 kW)

When connecting the protective conductor, either the upper or the lower screw can be used. One of the screws remains unused. "Looping-through" the protective connection to the line reactor is not permissible.

Line/load connection

Table 3- 6 Line and load connection, Basic Line Filter for Smart Line Modules

6SL3000-	0HE15-0AAx	0HE21-0AA.	0BE21-6DA.	0BE23-6DA1	0BE25-5DA.
Rated power [kW]	5	10	16	36	55
Line connection L1, L2, L3	Screw terminals 10 mm ² (AWG 8), 3-pole 1.2 ... 1.5 Nm (15 lbf in)			Screw terminals 35 mm ² (AWG 2), 3-pole 3.2 ... 3.7 Nm (32.7 lbf in)	Screw terminals 50 mm ² (AWG 1), 3-pole 6 ... 8 Nm (70.1 lbf in)
Load connection L1', L2', L3'					
Protective conductor connection ¹⁾	Terminal stud M6 / 6 Nm (53.1 lbf in)			Terminal stud M6 / 6 Nm (53.1 lbf in)	Terminal stud M8 / 8 Nm (70.1 lbf in)

¹⁾ For ring cable lugs without insulation (Page 710)

3.6.5.3 Dimension drawings

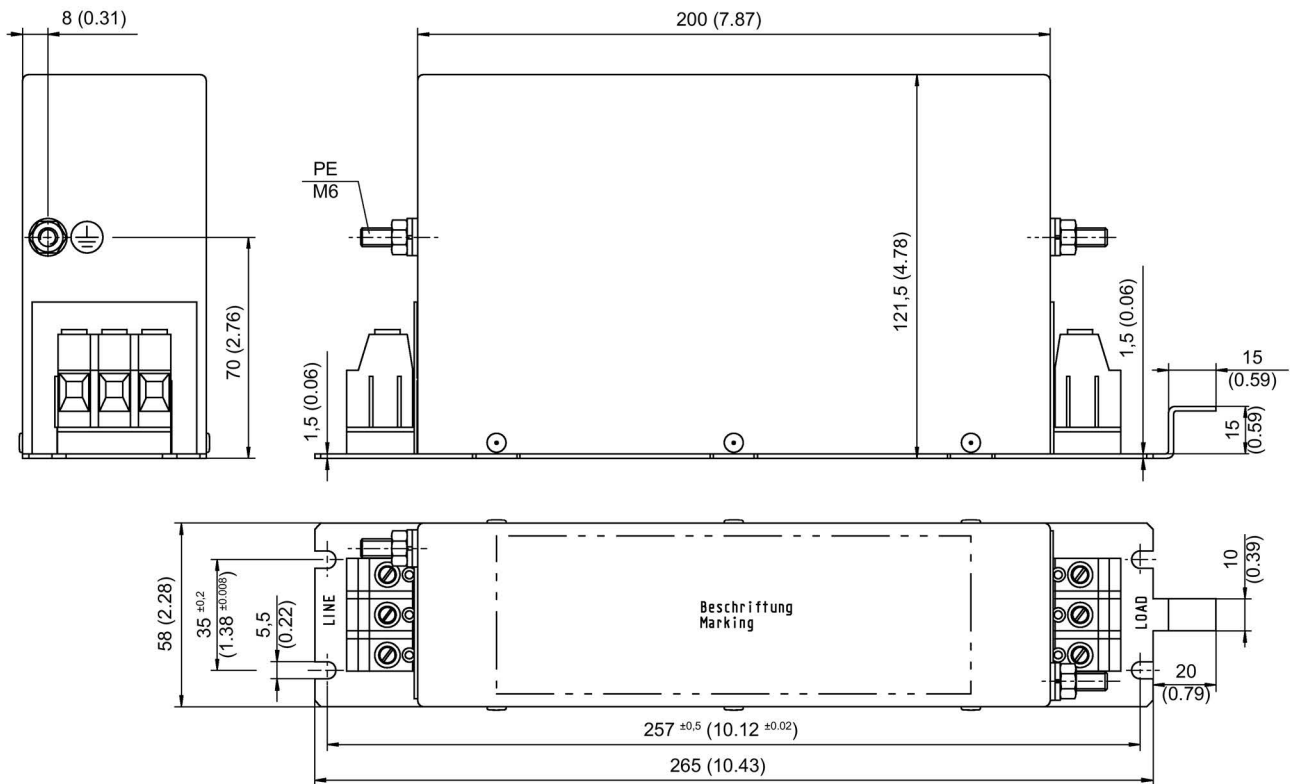

Figure 3-15 Dimension drawing of Basic Line Filter for 5 kW and 10 kW Smart Line Modules, all dimensions in mm and (inches)

3.6 Line filters

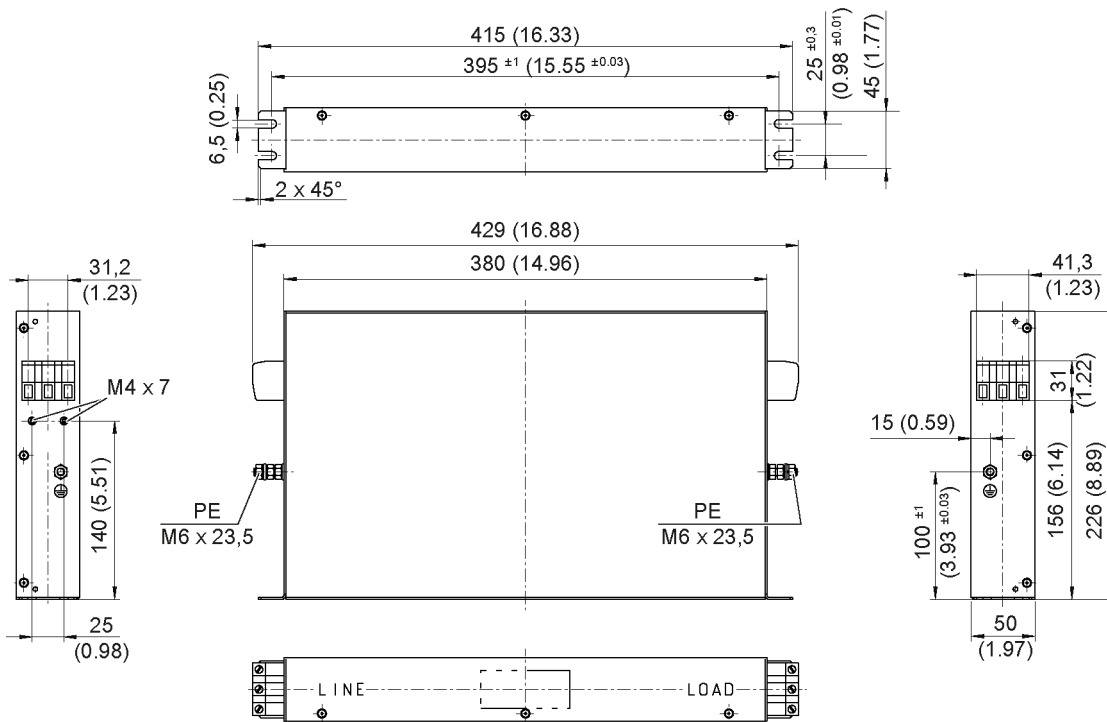

Figure 3-16 Dimension drawing of Basic Line Filter for Smart Line Modules 16 kW, all data in mm and (inches)

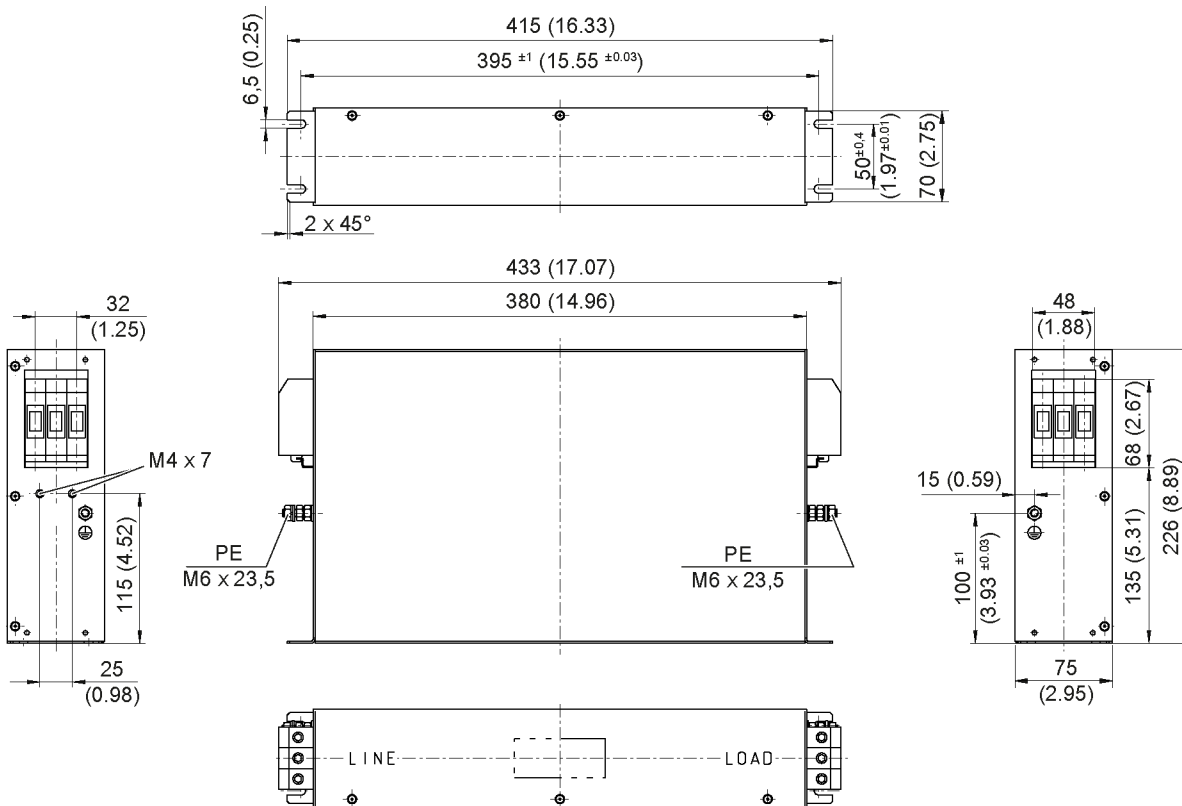

Figure 3-17 Dimension drawing of Basic Line Filter for Smart Line Modules 36 kW, all data in mm and (inches)

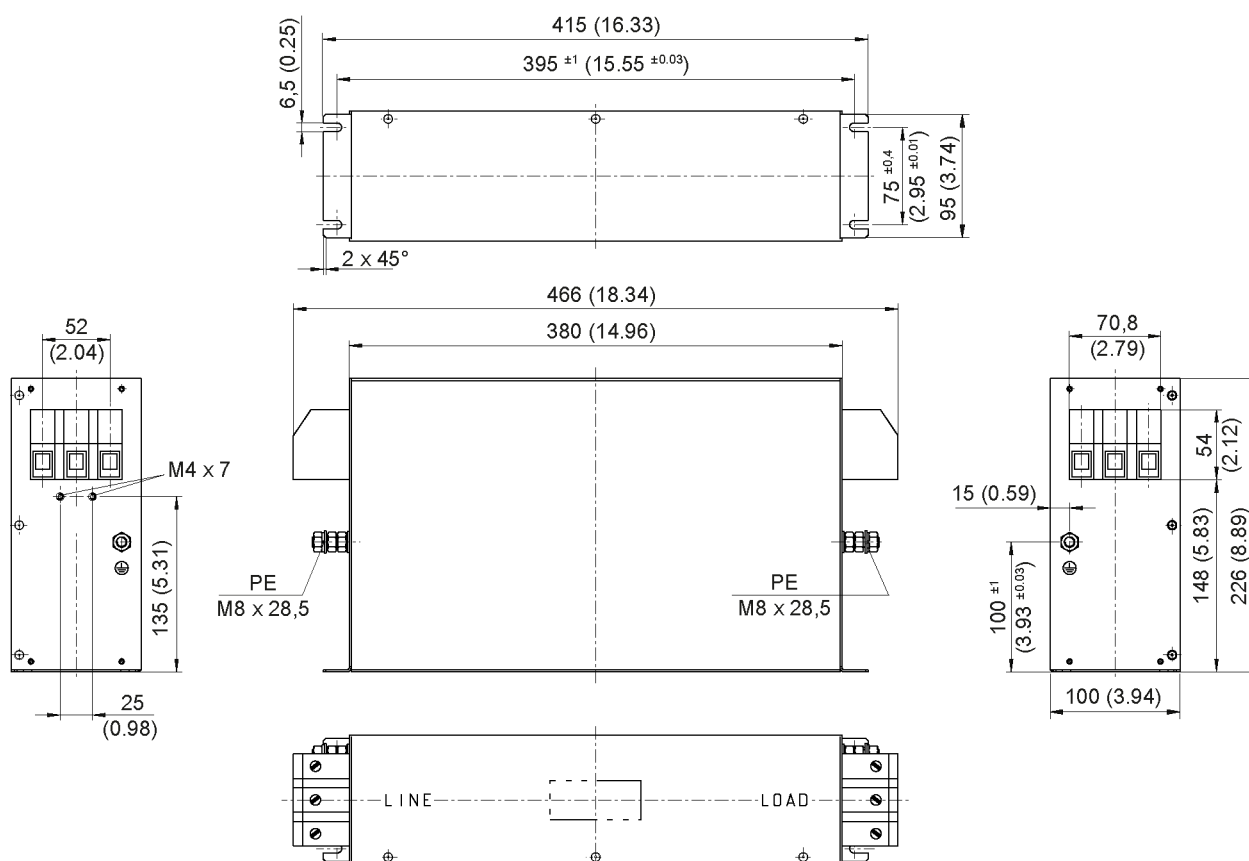

Figure 3-18 Dimension drawing of Basic Line Filter for Smart Line Modules 55 kW, all data in mm and (inches)

3.6.5.4 Technical data

Table 3-7 Technical data for: Basic Line Filter for Smart Line Modules

	6SL3000-	0HE15-0AA.	0HE21-0AA.	0BE21-6DA.	0BE23-6DA1	0BE25-5DA.
Rated power	kW	5	10	16	36	55
Supply voltage: Line voltage Line frequency	V _{AC} Hz	3 AC 380 -10 % (-15 % < 1 min) ... 3 AC 480 +10 % 47 ... 63				
Rated current	A _{AC}	12	25	36	74	105
Power loss (see power loss tables (Page 734))	W	20	20	16	26	43
Weight	kg	2.1	2.3	5	7.5	11.5
Mounting position		Any				

3.7 Line reactors

3.7.1 Safety instructions for line reactors



 WARNING
Electric shock in the event of missing touch protection
Contact with live parts can result in death or serious injury.
<ul style="list-style-type: none">• For the line reactors, use touch protection according to IPXXA or corresponding to the local installation regulations.



 WARNING
High voltages on the additional winding of the HFD line reactor
If system oscillations do occur and no damping resistor is connected, impermissibly high voltages may arise on the additional winding of the HFD line reactor.
Death or serious injury can result when live parts are touched.
<ul style="list-style-type: none">• Connect a damping resistor to the HFD line reactor.



 CAUTION
Burns resulting from high surface temperature of the line reactor
The line reactors can become very hot. You can get seriously burnt when touching the surface.
<ul style="list-style-type: none">• Mount the line reactors so that contact is not possible. If this is not possible, attach clearly visible and understandable warning notices at hazardous positions.• To prevent adjacent components from suffering damage due to these high temperatures, maintain a clearance of 100 mm on all sides of the line reactors.

NOTICE
Damage to the system caused by line reactors that are not permissible
Line reactors that are not permissible can damage the Line Modules.
Line harmonics that damage/disturb other loads connected to the same line supply can also occur.
<ul style="list-style-type: none">• Only use line reactors or Active Interface Modules described in this manual.

Note

Malfunctions through magnetic fields

Reactors produce magnetic fields that can disturb or damage components and cables.

- Arrange the components and cables at a suitable distance (at least 200 mm) or shield the magnetic fields appropriately.

Note

Length of connecting cables

The connection cables between line reactor and Line Module, as well as between line reactor and line filter, must be kept as short as possible (max. 10 m).

You must use shielded connection cables, whose cable shields are attached at both ends.

Shielding can only be omitted if the following conditions are met:

- The cables do not exceed 1 m in length.
- The cables are laid flush with the rear metal wall of the control cabinet.
- The cables are laid in a way that keeps them physically separate from signal cables.

All signal cables must be laid separately from the line reactor and from unshielded connection cables of the reactor with a minimum clearance of 200 mm.

3.7.2 Overview of the line reactors

Line reactors limit line harmonics to permissible values. For this reason, line reactors should always be used.

They must be used in conjunction with Active Line Modules as an energy storage device.

HFD line reactors have an additional winding, to which a separate damping resistor must be connected.

This dampens any possible system oscillations in converter systems to non-critical values. This results in increased operational reliability and extends the service life.

Depending on the parasitic resonance points, as a result of cable capacitances and line supply characteristics, system oscillations can occur with voltage amplitudes that can possibly reduce the service life of components.

Note

Recommendation

Use an Active Interface Module as line connection component for new plants and systems equipped with Active Line Modules.

3.7 Line reactors

The line reactors listed below are available for use with Line Modules.

Table 3- 8 Overview of line reactors

Line reactors	Article No.
Line reactors for Active Line Modules	
16 kW	6SL3000-0DE21-6AA.
36 kW	6SL3000-0DE23-6AA.
55 kW	6SL3000-0DE25-5AA.
80 kW	6SL3000-0DE28-0AA.
120 kW	6SL3000-0DE31-2AA.
Line reactors for Smart Line Modules	
5 kW	6SL3000-0CE15-0AA.
10 kW	6SL3000-0CE21-0AA.
16 kW	6SL3000-0CE21-6AA.
36 kW	6SL3000-0CE23-6AA.
55 kW	6SL3000-0CE25-5AA.
Line reactors for Basic Line Modules	
20 kW	6SL3000-0CE22-0AA.
40 kW	6SL3000-0CE24-0AA.
100 kW	6SL3000-0CE31-0AA.

3.7.3 Line reactors for Active Line Modules

3.7.3.1 Interface description

Overview

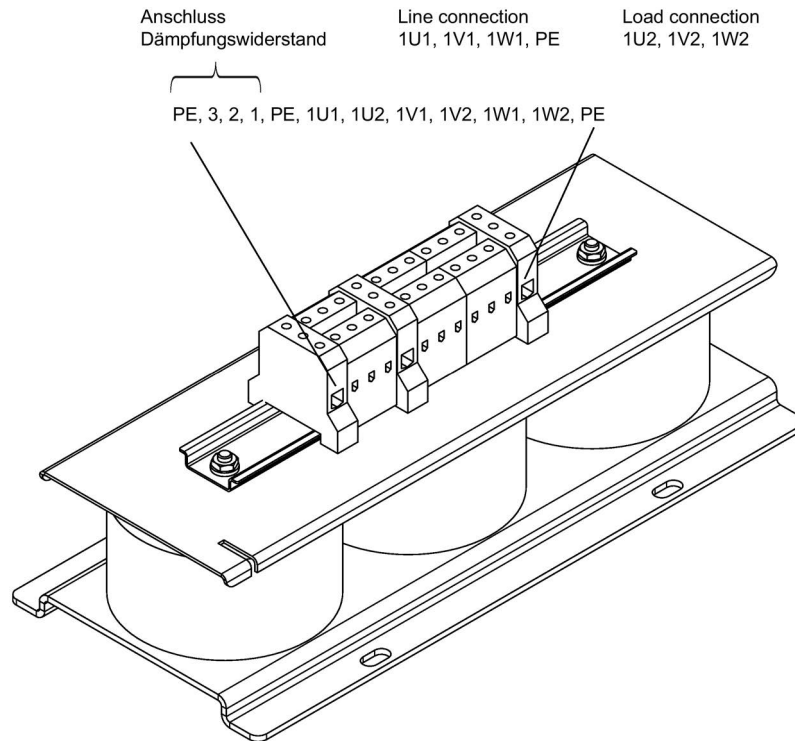

Figure 3-19 Interface overview, HFD line reactor 16 kW

3.7 Line reactors

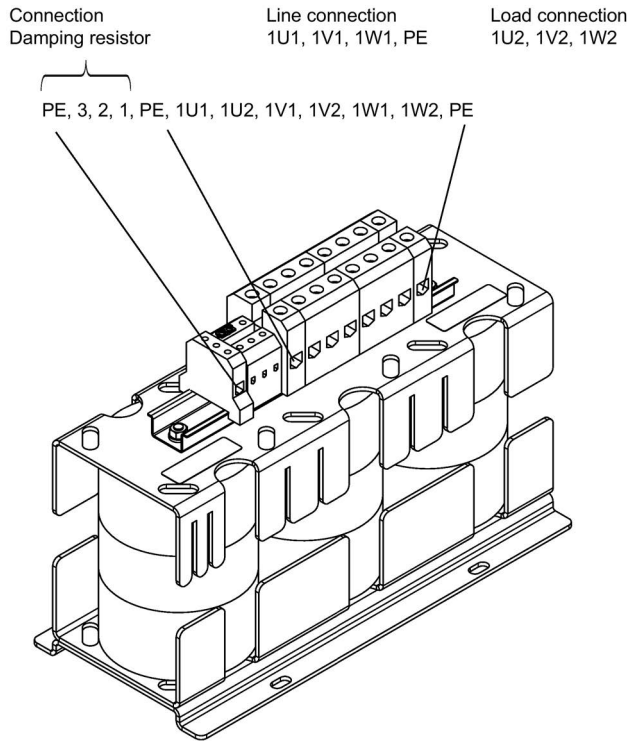

Figure 3-20 Interface overview, HFD line reactor 36 kW

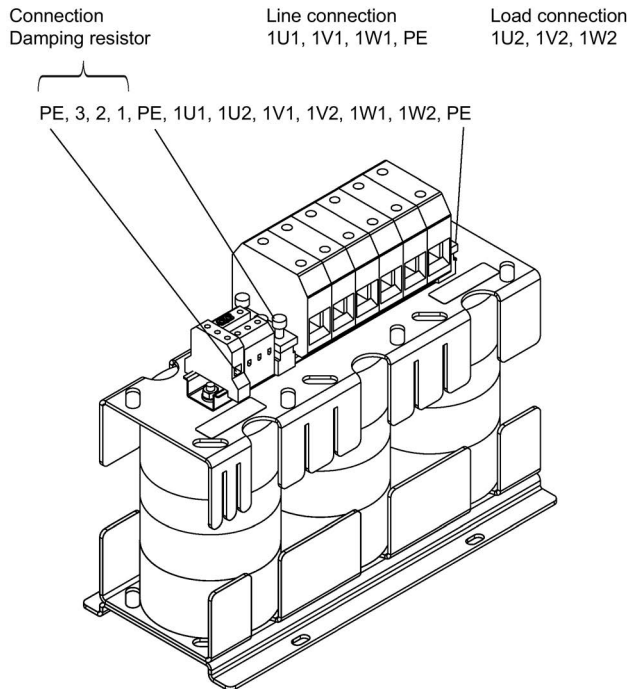

Figure 3-21 Interface overview, HFD line reactor 55 kW

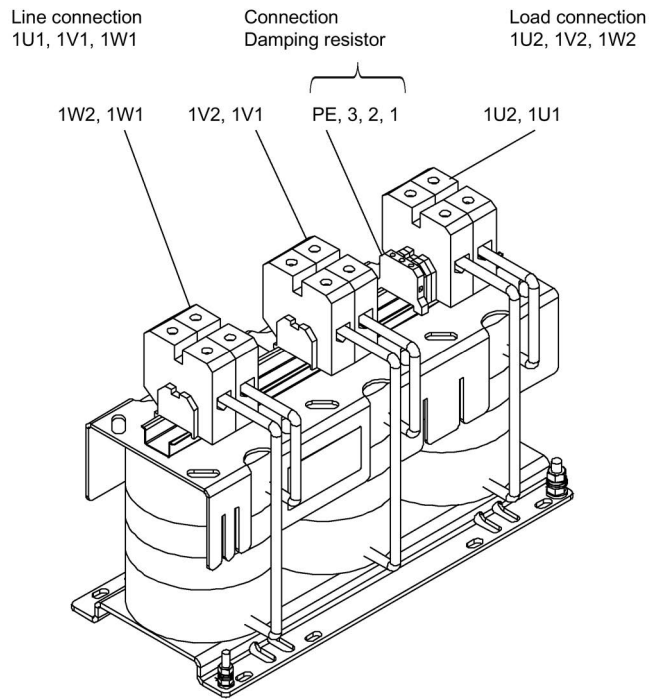

Figure 3-22 Interface overview, HFD line reactor 80 kW

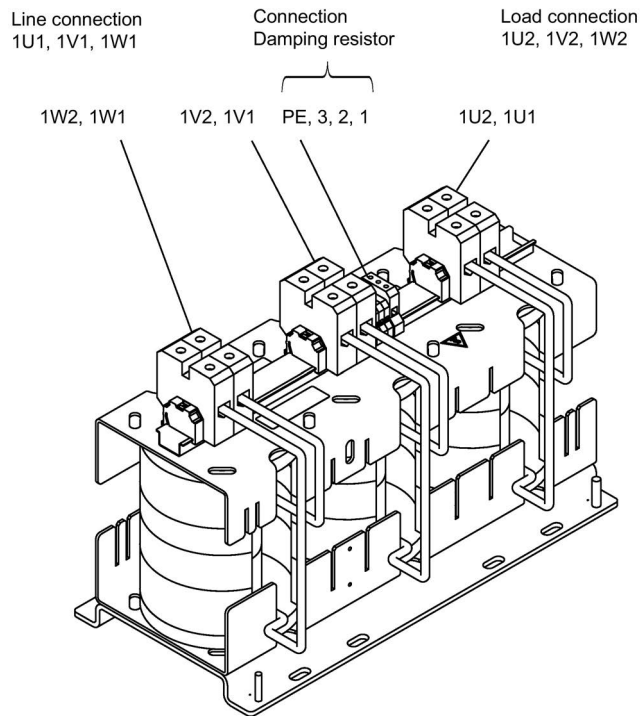

Figure 3-23 Interface overview, HFD line reactor 120 kW

3.7 Line reactors

Line/load connection

Table 3- 9 Connection of HFD line reactors

Article No.	6SL3000-0DE21-6AA.	6SL3000-0DE23-6AA.	6SL3000-0DE25-5AA.	6SL3000-0DE28-0AA.	6SL3000-0DE31-2AA.
Power [kW]	16	36	55	80	120
Line supply connection 1U1, 1V1, 1W1	Screw terminal 16 mm ² (AWG 6)	Screw terminal 35 mm ² (AWG 2)	Screw terminal 70 mm ² (AWG 2/0)	Type: Spring-loaded terminal 4 (Page 708)	
Load connection 1U2, 1V2, 1W2	1.2 Nm (10.6 lbf in)	2.5 Nm (22.1 lbf in)	6 ... 10 Nm (53.1 ... 88.5 lbf in)		
Protective conductor connection	Screw terminal 16 mm ² (AWG 6) 1.2 Nm (10.6 lbf in)				
Damping resistor connection 1, 2, 3 PE	Screw terminal 16 mm ² (AWG 6) 1.2 Nm (10.6 lbf in)				

Note

Data relating to the permissible tightening torques can also be found on the label showing the terminal layout of the screw terminal for the corresponding HFD line reactor.

3.7.3.2 Dimension drawings

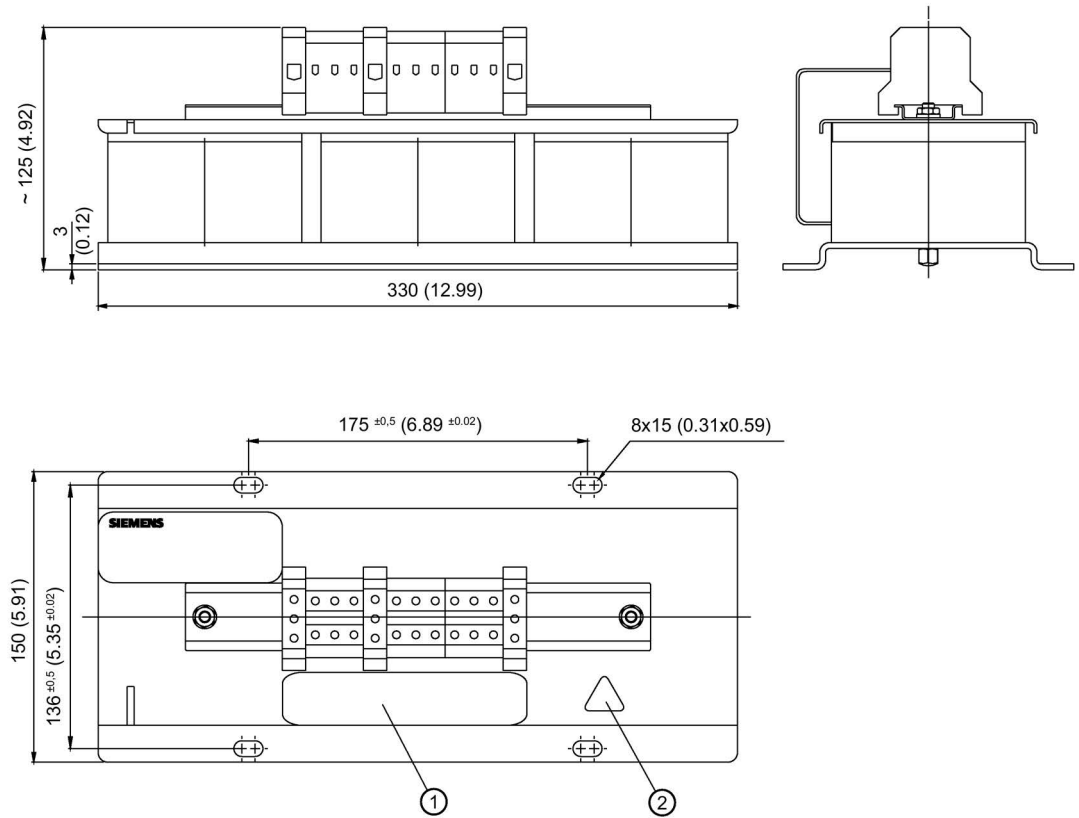

- ① Terminal arrangement
- ② Warning label

Figure 3-24 Dimension drawing of HFD line reactor 16 kW, all dimensions in mm and (inches)

3.7 Line reactors

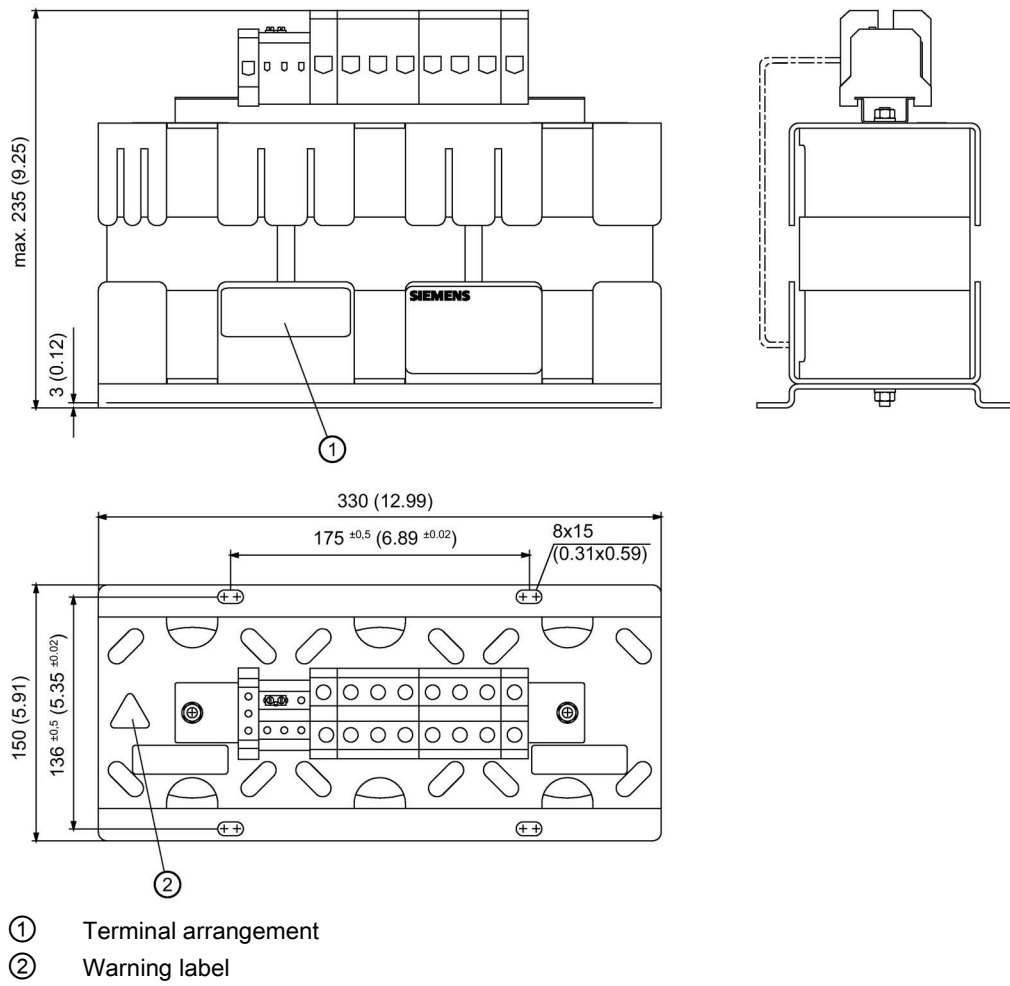
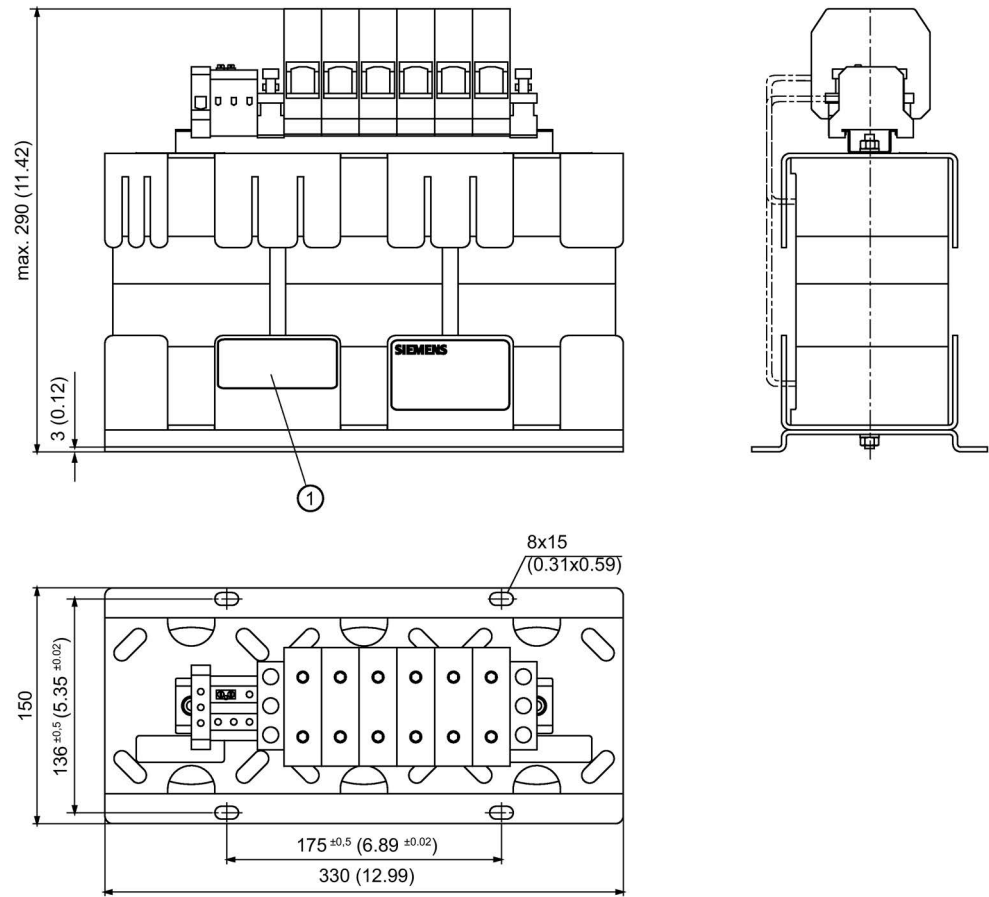

Figure 3-25 Dimension drawing of HFD line reactor 36 kW, all dimensions in mm and (inches)



① Terminal arrangement

Figure 3-26 Dimension drawing of HFD line reactor 55 kW, all dimensions in mm and (inches)

3.7 Line reactors

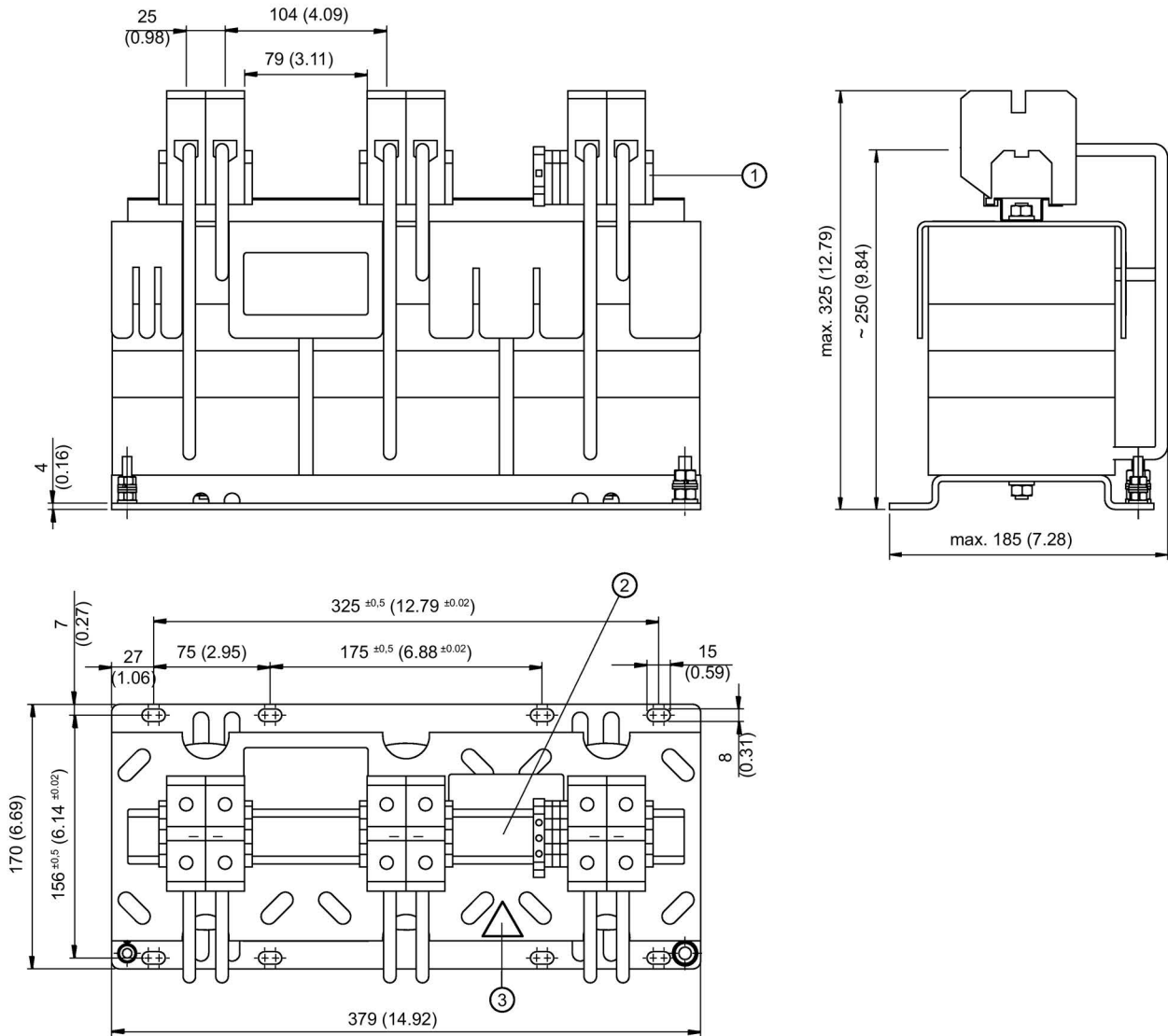

- ① End retainers
- ② Terminal arrangement
- ③ Warning label

Figure 3-27 Dimension drawing of HFD line reactor 80 kW, all dimensions in mm and (inches)

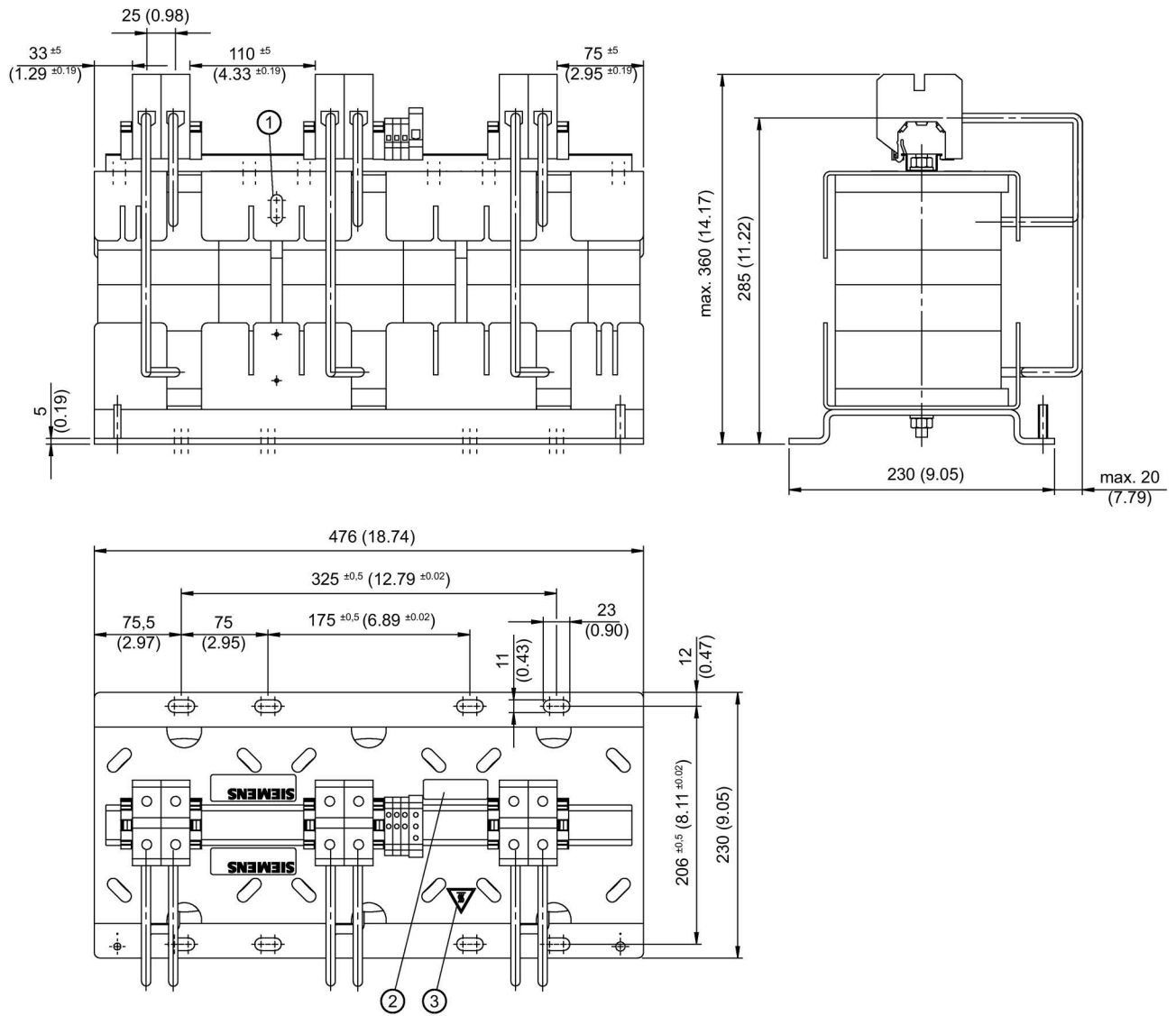

Figure 3-28 Dimension drawing of HFD line reactor 120 kW, all dimensions in mm and (inches)

3.7 Line reactors

3.7.3.3 Technical data

Table 3- 10 Technical data for HFD line reactors

	6SL3000-	0DE21-6AA.	0DE23-6AA.	0DE25-5AA.	0DE28-0AA.	0DE31-2AA.
Power	kW	16	36	55	80	120
Rated current	A _{rms}	30	67	103	150	225
Power loss ¹⁾ (see power loss tables)	W	170	250	350	450	590
Weight	kg	9	23	27	37	67
Degree of protection to IEC 60529		IP00 (no touch protection)				
Mounting position		Any				

¹⁾ Data for line operation

3.7.4 Damping resistor for HFD line reactors

3.7.4.1 Description

Using a damping resistor

In some systems, oscillations can be generated which place an impermissibly high strain on the insulation systems of the motors and converters involved. Connecting a damping resistor to the additional winding of the HFD line reactor is an effective means of damping just such system oscillations. Use of the 800 W damping resistor is preferable.

Note

Recommendation

Use an Active Interface Module as line connection component for new plants and systems equipped with Active Line Modules.

3.7.4.2 Safety instructions for damping resistors for HFD reactors

! CAUTION
Burns due to high surface temperatures of the damping resistor

The damping resistor can become very hot. You can get seriously burnt when touching the surface.

- Mount the damping resistors so that contact is not possible. If this is not possible, attach a clearly visible and understandable warning notice at hazardous positions.
- To prevent adjacent components from suffering damage due to these high temperatures, maintain a clearance of 100 mm on all sides of the damping resistors.

Note
Installation

- Preferably mount the damping resistors outside of the control cabinet.

3.7.4.3 Dimension drawings

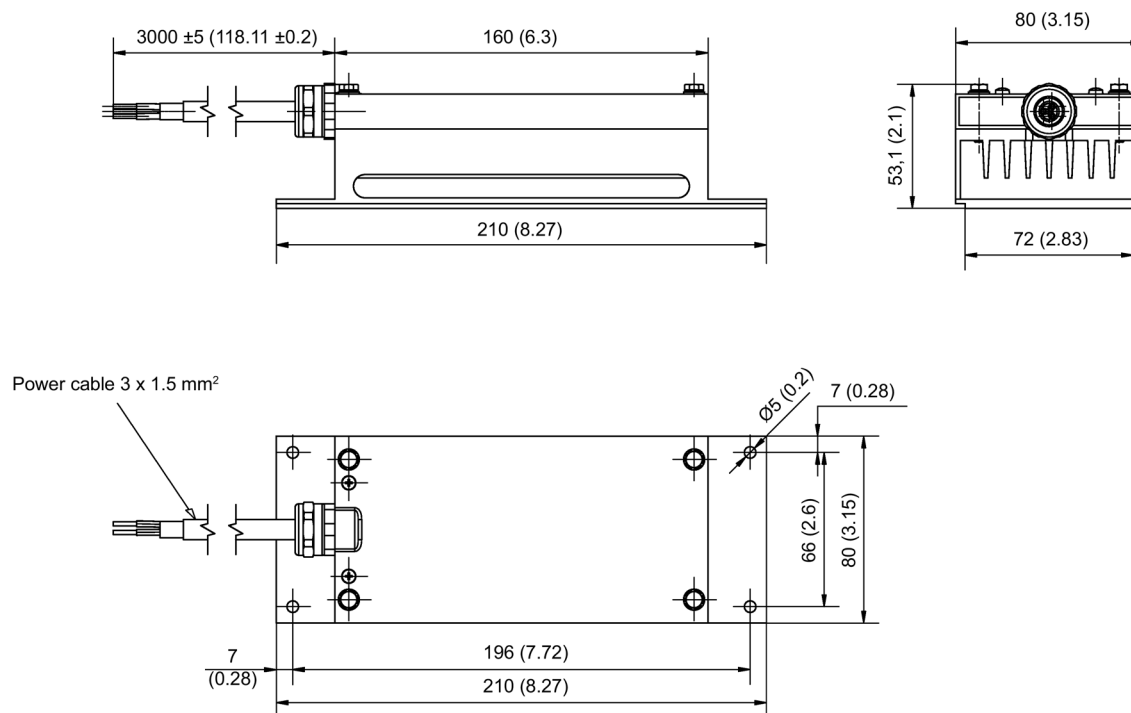

Figure 3-29 300 W damping resistor for HFD line reactors, all dimensions in mm and (inches)

3.7 Line reactors

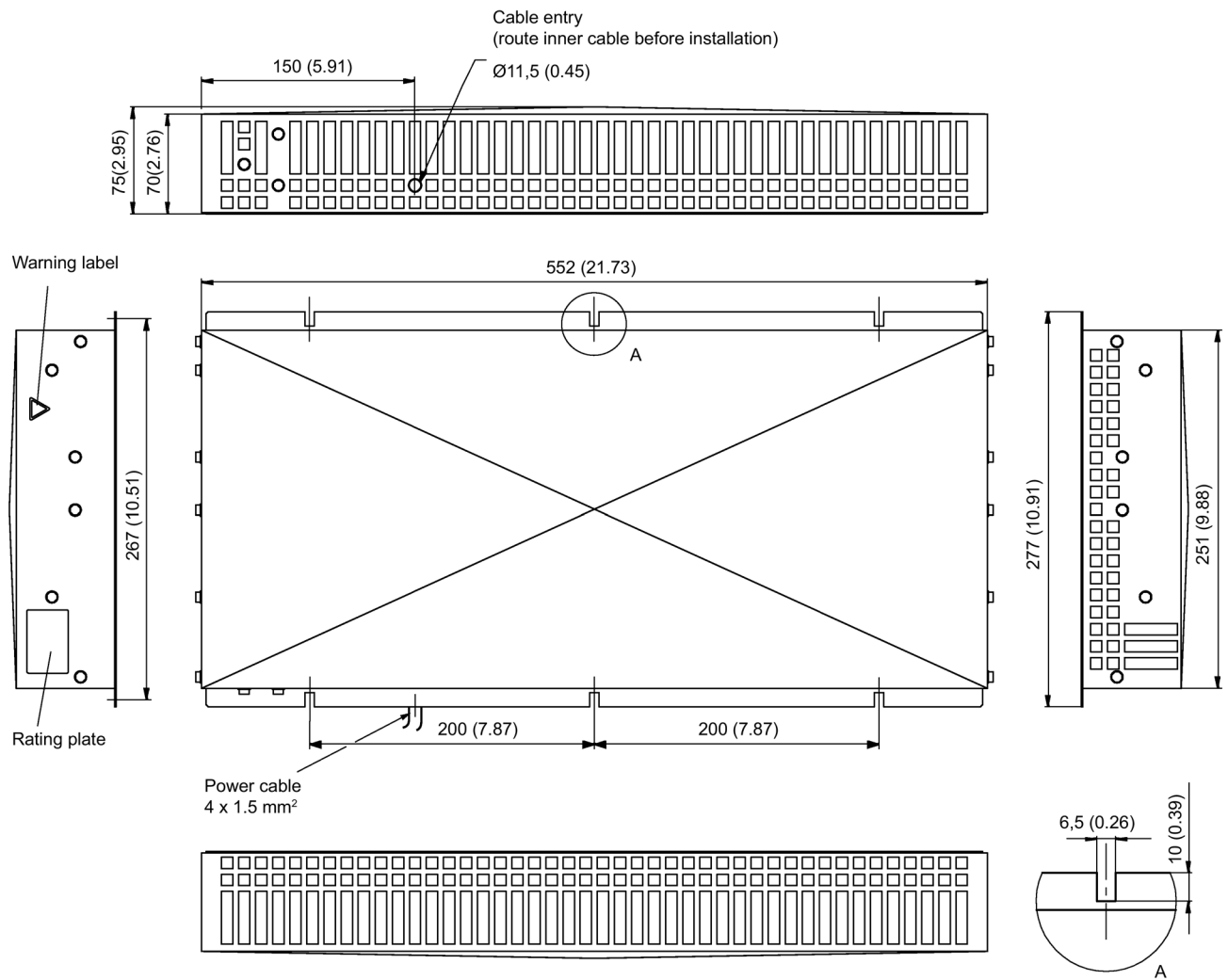

Figure 3-30 800 W damping resistor for HFD line reactors, all dimensions in mm and (inches)

3.7.4.4 Technical data

Together with the HFD line reactor, an external resistor must be used for damping purposes (refer to Chapter Wiring with the HFD line reactor (Page 88)).

Table 3- 11 Technical data for HFD damping resistors

Article No.	6SN1113-1AA00-0DA. ¹⁾	6SL3100-1BE21-3AA. ²⁾
Rated power [W]	300	800
Connection cable [m], included in scope of delivery	3	5
Connection	3 x 1.5 mm ²	4 x 1.5 mm ²
Weight [kg]	1.45	5.5
Degree of protection to IEC 60529	IP54	IP51
Ambient temperature [°C]	0 ... 55	
Dimensions (W x H x D) [mm]	80 x 210 x 53	277 x 552 x 75

- 1) The 300 W damping resistor can be used for HFD applications if the following is true after a heat run when all axes are shut down in a regulated way:
- After an operating period of over two hours, the surface temperature of resistor 6SN1113-1AA00-0DA0 must not exceed 150° C.
 - This heat run must be repeated if the hardware configuration, e.g. motor cable lengths, is changed.
- 2) Preferred type

3.7.4.5 Wiring with the HFD line reactor

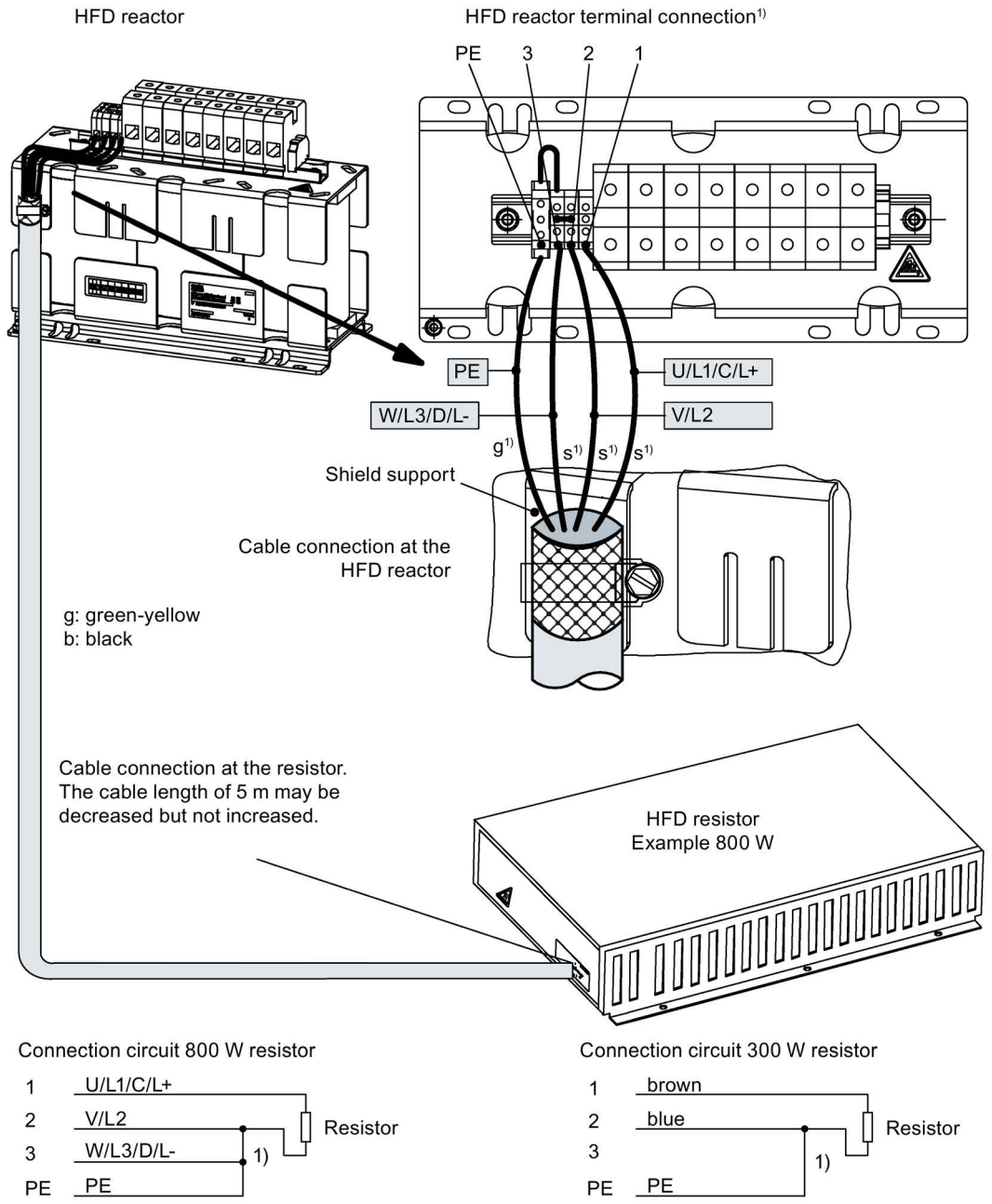

¹) Terminals 2 and 3 are connected in the HFD reactor with protective conductor potential for the potential connection of the damping resistor and unused wires.

Note:
It is not permissible that any cables are routed in the area where hot air is dissipated from the damping resistor.

Mounting position:
Arbitrary mounting position but consider the heat dissipation, if necessary, provide a "Hot surface" warning notice!

Figure 3-31 Wiring the HFD line reactor with a damping resistor

3.7.5 Line reactors for Basic Line Modules

3.7.5.1 Interface description

Overview

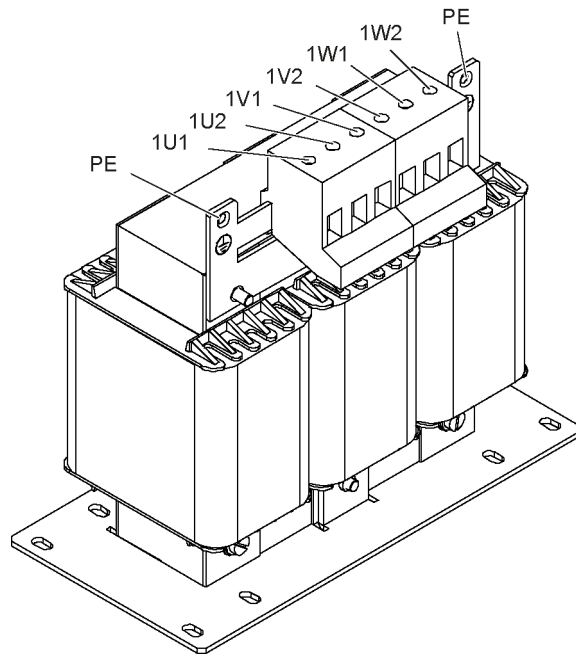

Figure 3-32 Interface overview, line reactor for Basic Line Modules (20 kW)

3.7 Line reactors

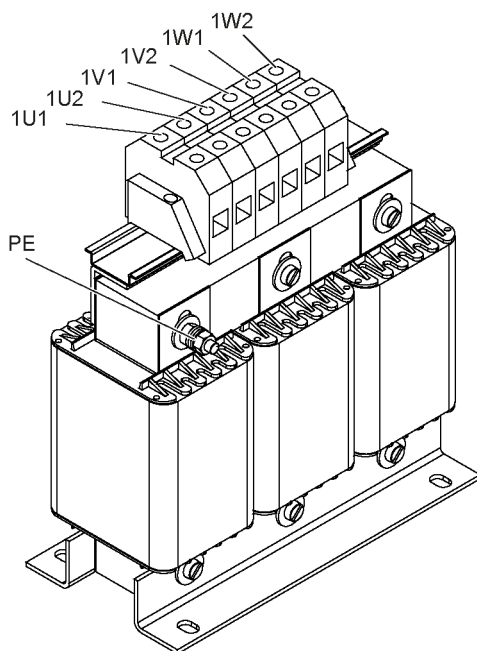

Figure 3-33 Interface overview, line reactor for Basic Line Modules (40 kW)

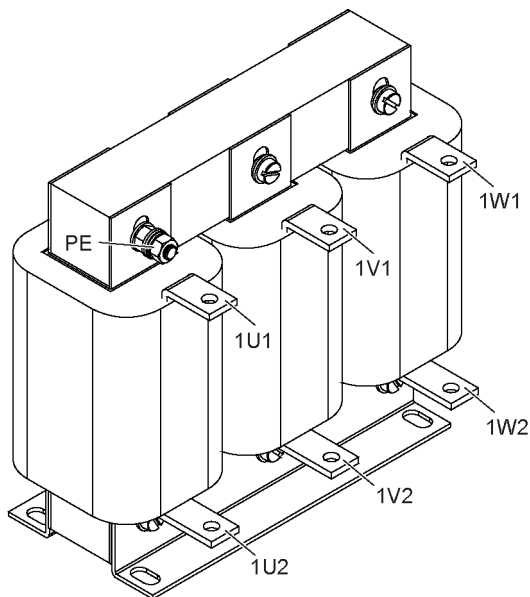

Figure 3-34 Interface overview, line reactor for Basic Line Modules (100 kW)

Line/load connection

Table 3- 12 Line and load connection line reactors for Basic Line Modules

	6SL3000-0CE22-0AA.	6SL3000-0CE24-0AA.	6SL3000-0CE31-0AA.
Power	20 kW	40 kW	100 kW
Line supply connection 1U1, 1V1, 1W1	Screw terminals 10 mm ² (AWG 8)	Screw terminals 35 mm ² (AWG 2)	Copper busbars with 8.5 mm diameter holes
Load connection 1U2, 1V2, 1W2	1.5 ... 1.8 Nm (15.9 lbf in)	5 ... 6 Nm (53.1 lbf in)	
Protective conductor connection	Screw M4 2 Nm (17.7 lbf in)	Terminal stud M6 ¹⁾ 6 Nm (53.1 lbf in)	Terminal stud M8 ¹⁾ 12 Nm (106 lbf in)
1) For ring cable lugs without insulation (Page 710)			

3.7.5.2 Dimension drawings

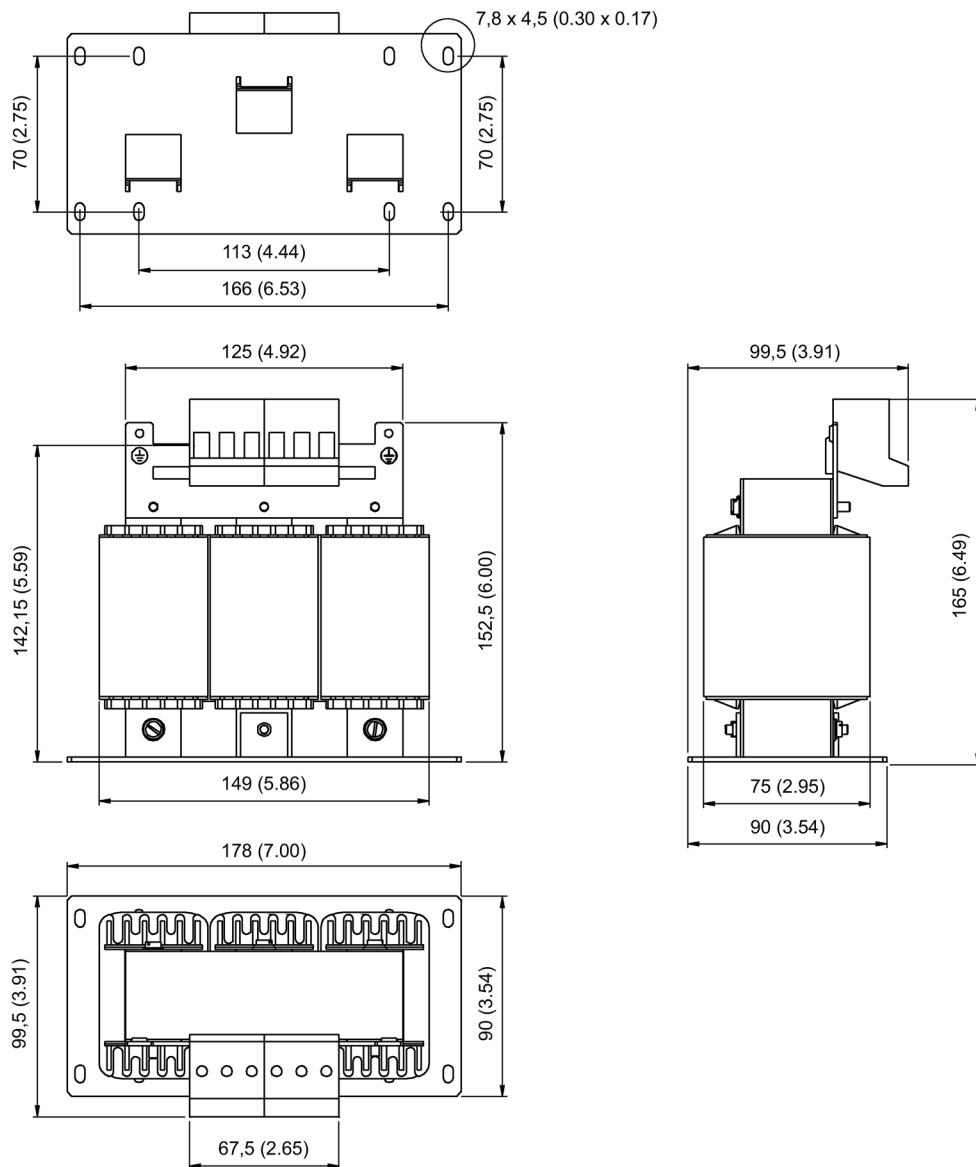

Figure 3-35 Dimension drawing of line reactor for Basic Line Module 20 kW, all dimensions in mm and (inches)

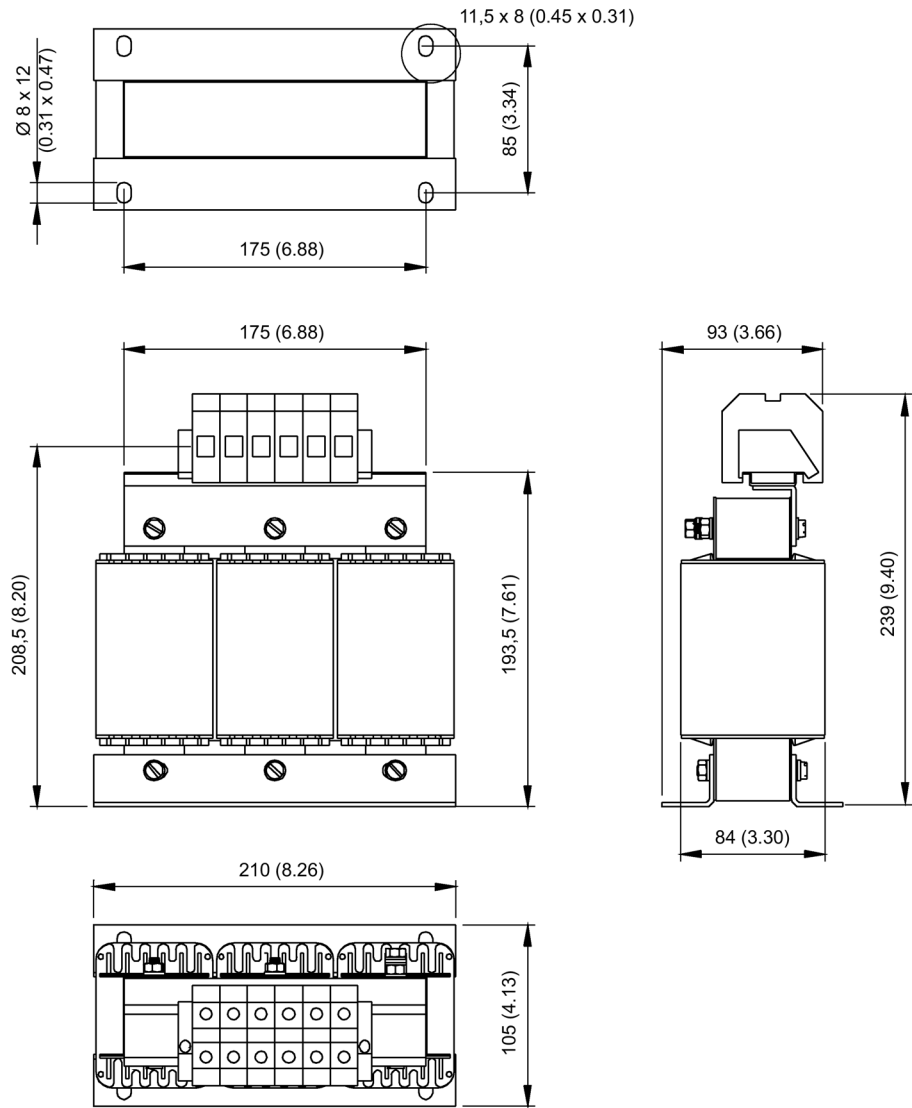

Figure 3-36 Dimension drawing of line reactor for Basic Line Module 40 kW, all dimensions in mm and (inches)

3.7 Line reactors

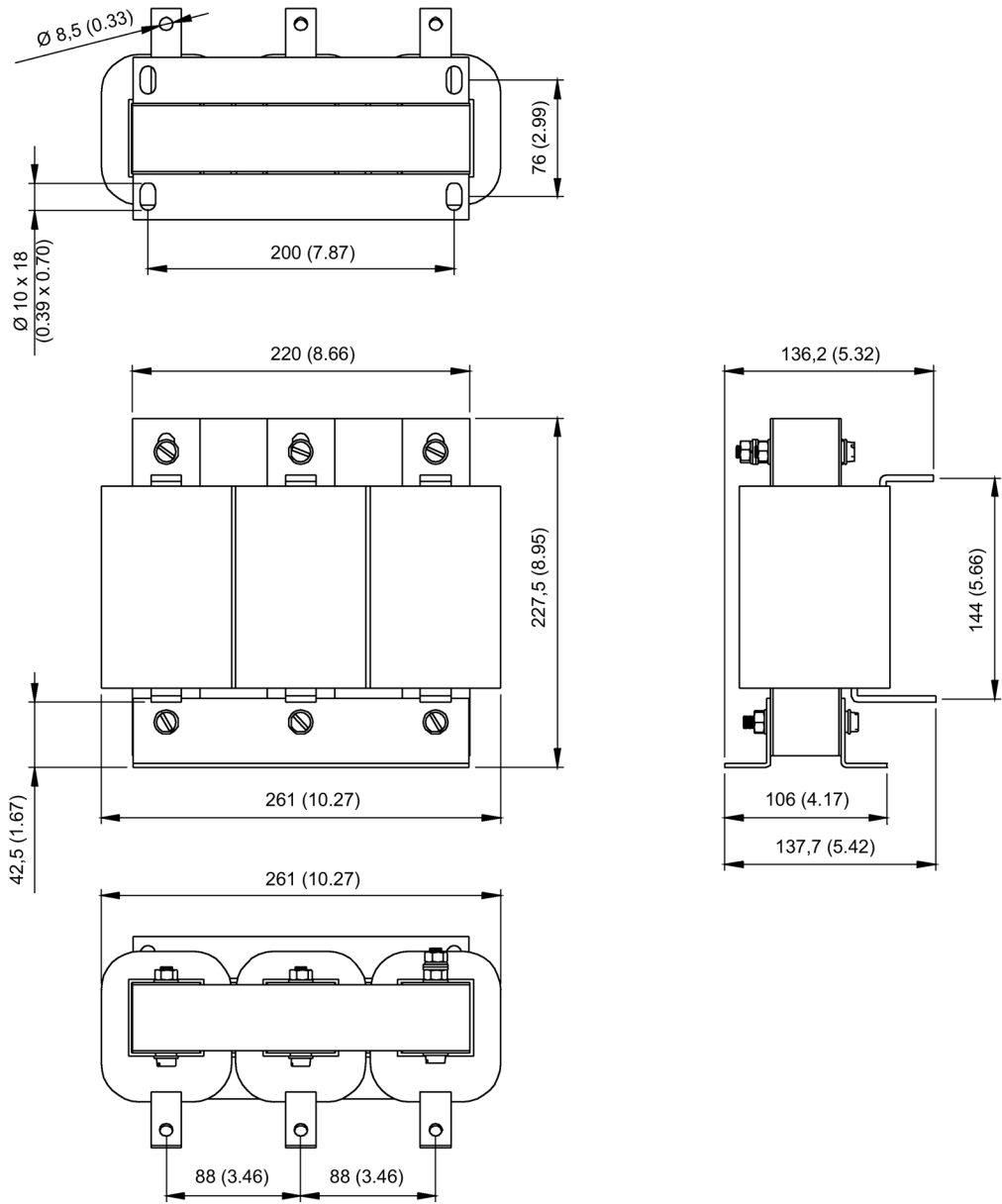

Figure 3-37 Dimension drawing of line reactor for Basic Line Module 100 kW, all dimensions in mm and (inches)

3.7.5.3 Technical data

Table 3- 13 Technical data of line reactors for the Basic Line Modules

	Unit	6SL3000-0CE22-0AA.	6SL3000-0CE24-0AA.	6SL3000-0CE31-0AA.
Power	kW	20	40	100
Rated current	A_{rms}	37	74	185
Power loss (see power loss tables (Page 734))	W	130	270	480
Weight	kg	5.2	11.2	21.7

3.7.6 Line reactors for Smart Line Modules

3.7.6.1 Interface description

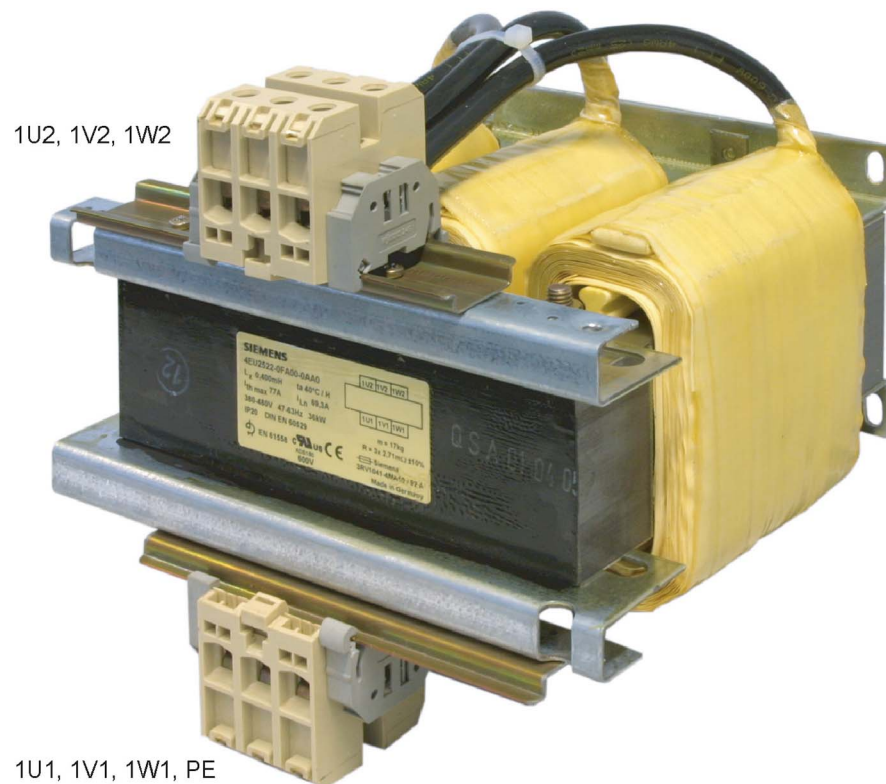

Figure 3-38 Interface overview, line reactors for Smart Line Modules (example: 36 kW)

3.7 Line reactors

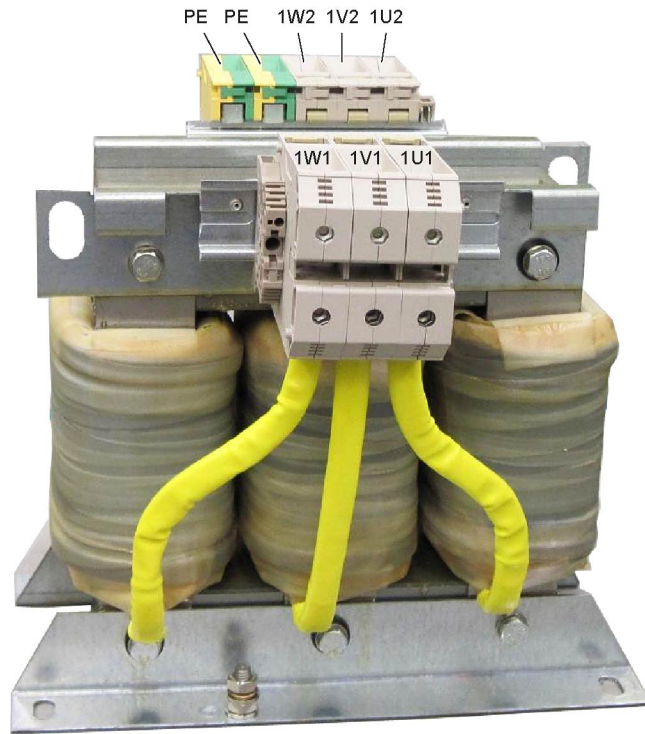

Figure 3-39 Interface overview, line reactors for Smart Line Modules (example: 55 kW)

Line/load connection

Table 3- 14 Line and load connection line reactors for Smart Line Modules

	6SL3000-0CE15-0AA.	6SL3000-0CE21-0AA.	6SL3000-0CE21-6AA.	6SL3000-0CE23-6AA.	6SL3000-0CE25-5AA.
Power	5 kW	10 kW	16 kW	36 kW	55 kW
Terminal designations					
Mains connection	L1, L2, L3	L1, L2, L3	1U1, 1V1, 1W1	1U1, 1V1, 1W1	1U1, 1V1, 1W1
Load connection	L1.2, L2.2, L3.2	L1.2, L2.2, L3.2	1U2, 1V2, 1W2	1U2, 1V2, 1W2	1U2, 1V2, 1W2
Line connection	Screw terminals	Screw terminals	Screw terminals	Screw terminals	Screw terminals
Load connection	4 mm ² (AWG 12)	10 mm ² (AWG 8)	10 mm ² (AWG 8)	35 mm ² (AWG 2)	70 mm ² (AWG 2/0)
	0.6 ... 0.8 Nm (7.1 lbf in)	1.5 ... 1.8 Nm (15.9 lbf in)	1.2 ... 1.5 Nm (13.3 lbf in)	2.5 Nm (22.1 lbf in)	8 ... 12 Nm (106 lbf in)
Protective conductor connection	Screw M4 2 Nm (17.7 lbf in)	Screw M4 2 Nm (17.7 lbf in)	Terminal studs M5 ¹⁾	Terminal studs M6 ¹⁾	Terminal studs M8 ¹⁾

¹⁾ For ring cable lugs without insulation (Page 710)

3.7.6.2 Dimension drawings

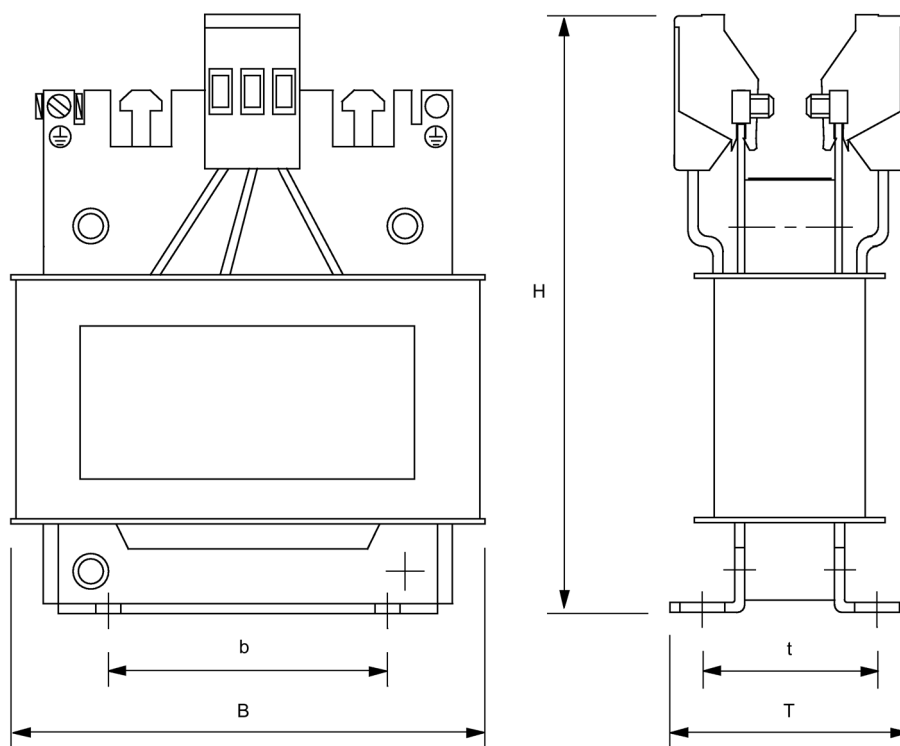

Figure 3-40 Dimension drawing of line reactor for Smart Line Modules 5 kW and 10 kW

Table 3- 15 Dimensions of line reactors for Smart Line Modules (5 kW and 10 kW)

	Article number 6SL3000-	B [mm] (inch)	b [mm] ¹⁾ (inch)	H [mm] (inch)	T [mm] (inch)	t [mm] ¹⁾ (inch)
5 kW	0CE-15-0AAx	150 (5.91)	113 (4.53)	175 (6.89)	66.5 (2.62)	49.5 (1.95)
10 kW	0CE-21-0AAx	177 (6.97)	136 (5.35)	196 (7.72)	86 (3.39)	67 (2.64)

¹⁾ Lengths b and t correspond to the distance between holes

3.7 Line reactors

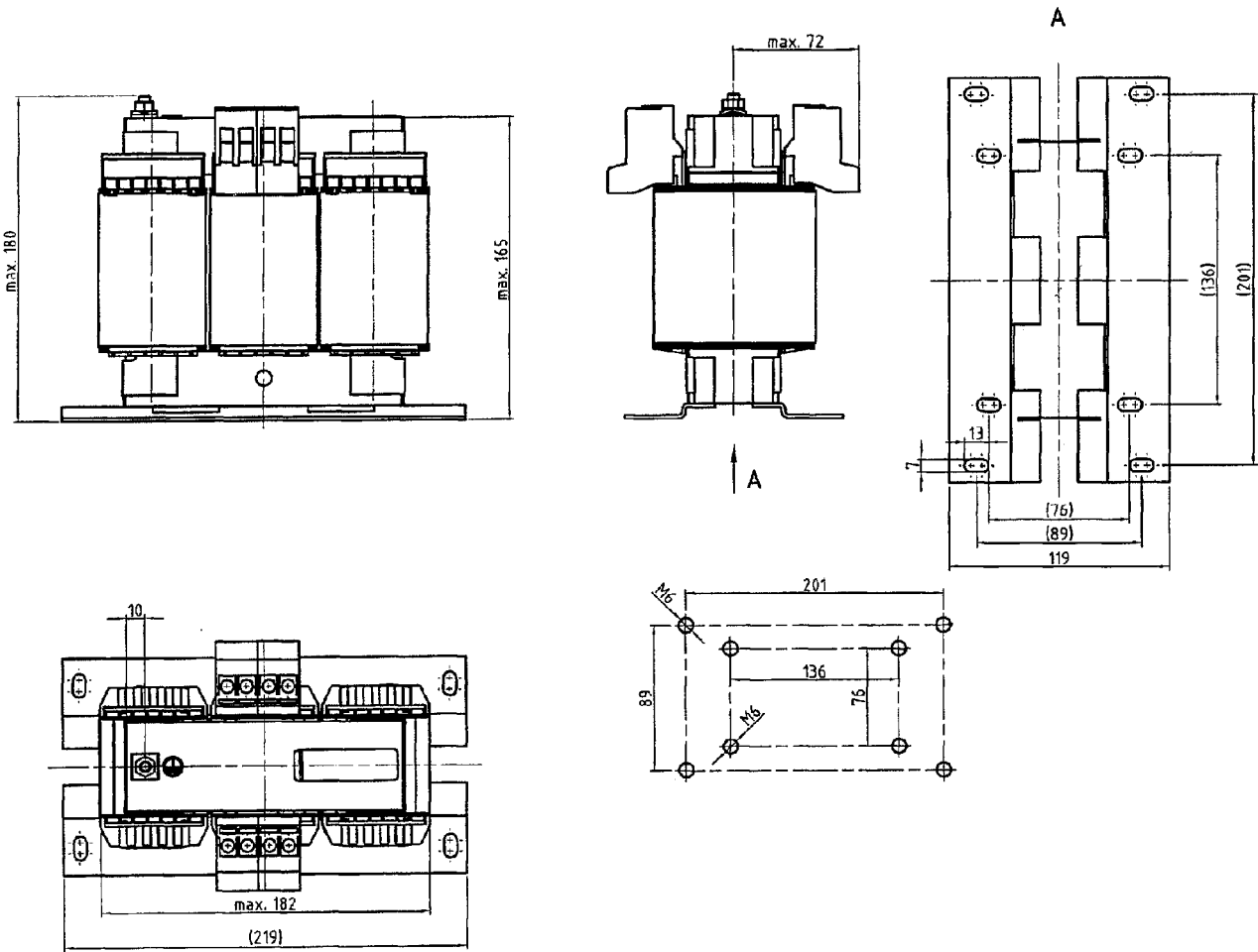

Figure 3-41 Dimension drawing of line reactor for Smart Line Module 16 kW

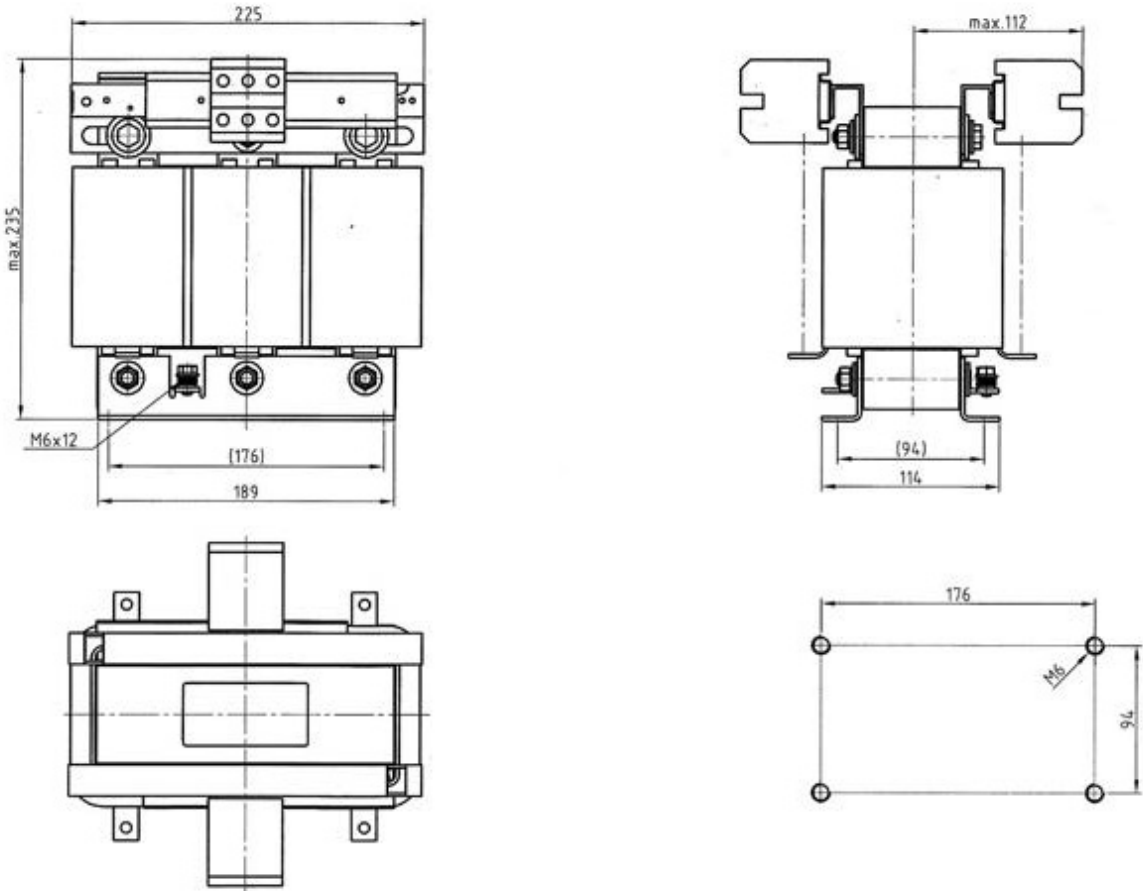

Figure 3-42 Dimension drawing of line reactor for Smart Line Module 36 kW

3.7 Line reactors

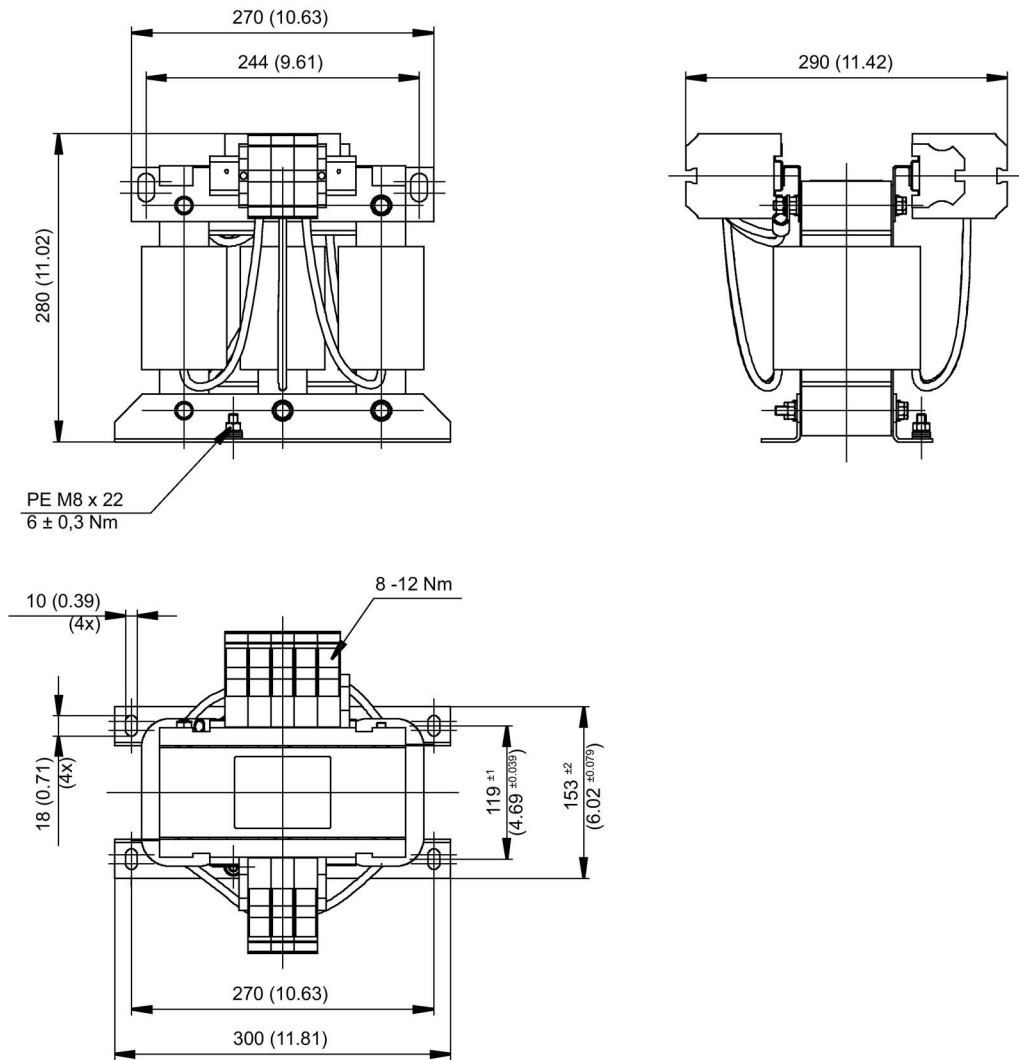

Figure 3-43 Dimension drawing of line reactor for Smart Line Module 55 kW, all dimensions in mm and (inches)

3.7.6.3 Technical data

Table 3- 16 Technical data of line reactors for the Smart Line Module

		6SL3000-0CE15-0AA.	6SL3000-0CE21-0AA.	6SL3000-0CE21-6AA.	6SL3000-0CE23-6AA.	6SL3000-0CE25-5AA.
Power	kW	5	10	16	36	55
Rated current	A_{rms}	14	28	35	69	103
Power loss (see power loss tables (Page 734))	W	62	116	110	170	190
Weight	kg	3.7	7.5	9.5	17	37
Mounting position		Upright vertically or hanging horizontally				

3.8 Active Interface Modules internal air cooling

3.8.1 Description

Active Interface Modules are line-side interfaces for the Active Line Modules.

They contain the following functional units:

- Line reactor
- Low-frequency/switching frequency filters
- Line filter EN 61800-3 Category C3 up to 350 m total motor cable length¹⁾ (shielded)
- Reduction of the stress on the motor insulation from system-dependent resonance factors

Note

Active Interface Modules may only be operated in conjunction with the associated Active Line Modules from Siemens.

Data regarding the radio interference voltage categories and maximum total cable lengths that can be achieved¹⁾ see Chapter Combination options, Line Modules with line reactors and line filters (Page 120).

The Active Interface Module is fitted with a fan. The 24 V supply is essential for operating the component. Connection of the temperature signaling contact to the Active Line Module is also required.

¹⁾ Maximum total cable length = Σ motor cables, line feeder cable from line filter to the Line Module

3.8.2 Safety instructions for Active Interface Modules



! WARNING

Electric shock due to the residual charge of the filter capacitors

Because of the filter capacitors, a hazardous voltage is present for up to 5 minutes after the power supply has been switched off. Contact with live parts can result in death or serious injury.

- Do not open the protective cover of an AIM 80 kW and AIM 120 kW until 5 minutes have elapsed.
- Always measure the voltage at the line and load connecting terminals before starting any work.



! WARNING

Electric shock due to unconnected cable shields

Hazardous touch voltages can occur through capacitive cross-coupling due to unconnected cable shields.

- Connect cable shields and the conductors of power cables that are not used (e.g. brake conductors) at both ends at the grounded housing potential.



! WARNING

High leakage currents when the protective conductor in the line feeder cable is interrupted

The drive components conduct a high leakage current via the protective conductor. Touching conductive parts when the protective conductor is interrupted can result in death or serious injury.

- Carefully comply with the applicable regulations for dimensioning the protective conductor (see Chapter "Protective connection and equipotential bonding (Page 714)").

! WARNING

Fire due to overheating resulting from excessively long connecting cables

Excessively long cable lengths can cause components to overheat with the associated risk of fire and smoke.

- The total cable length between an Active Interface Module and Active Line Module as well as between an Active Interface Module and Basic Line Filter must not exceed 10 m.



! CAUTION

Burns due to high surface temperatures

The surface of the components can reach high temperatures during operation. You can get seriously burnt when touching the surface.

- Do not touch the component.

NOTICE**Damage to the Active Interface Module due to incorrect settings made during commissioning**

The Active Interface Module can be damaged through incorrect settings in the software.

- Do not use any SINAMICS firmware version less than V2.5.
- Operate Active Interface Modules only with the following settings in the commissioning wizard:
 - Set the "Line filter available" option for the Active Line Module.
 - Select line filter "AIM 400 V ..kW (6SL3100-0BE..-AB.)".

With firmware version SINAMICS V2.5, the default setting in STARTER/SCOUT is "Wideband Line Filter". Switchover parameter p0220 to "AIM" (see SINAMICS S120/S150 List Manual).

In conjunction with SINAMICS from V2.6 and higher, the appropriate Active Interface Module is already preset by running the wizard in STARTER.

NOTICE**Damage to the Active Interface Module due to incorrect or missing wiring**

The Active Interface Module can be damaged through incorrect wiring or a missing 24 V supply.

- Before commissioning the Active Interface Module, it is essential to connect the 24 V DC at connector X124 to supply the fans.
- Connect the temperature signaling contact of the Active Interface Module to the temperature input of the associated Active Line Module.

NOTICE**Damage caused by overheating as a result of an inadmissible mounting position**

When incorrectly mounted, the Active Interface Module can overheat and therefore be damaged.

- Only operate the Active Interface Module in a vertical position with the line connection at the bottom.

Note**Functional disturbances as a result of line supply disturbances**

The devices have been tested for standard line supplies according to EN 61800-3. For line supplies with significant disturbances (e.g. total harmonic distortion (THD) > 8 %; very high percentage of switching peaks in the range > 1 kV), the filter of the line-up can be overloaded as a result of the additional filter power.

- Decouple the drive line-ups using suitable measures:
 - Using a Basic Line Filter
 - Use an HFD line reactor with damping resistor instead of an Active Interface Module

3.8.3 Interface description

3.8.3.1 Overview

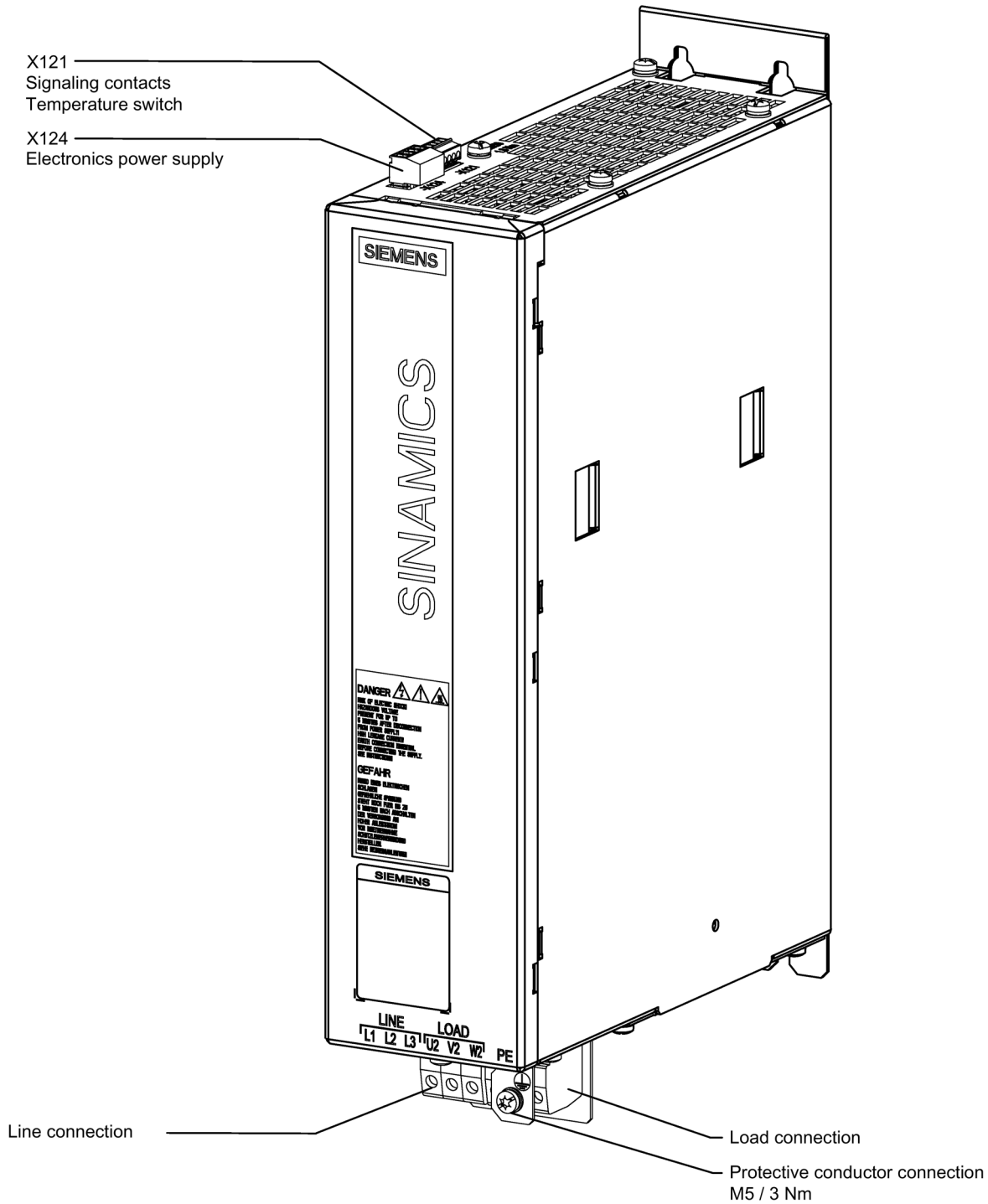

Figure 3-44 Interface overview, Active Interface Module 16 kW

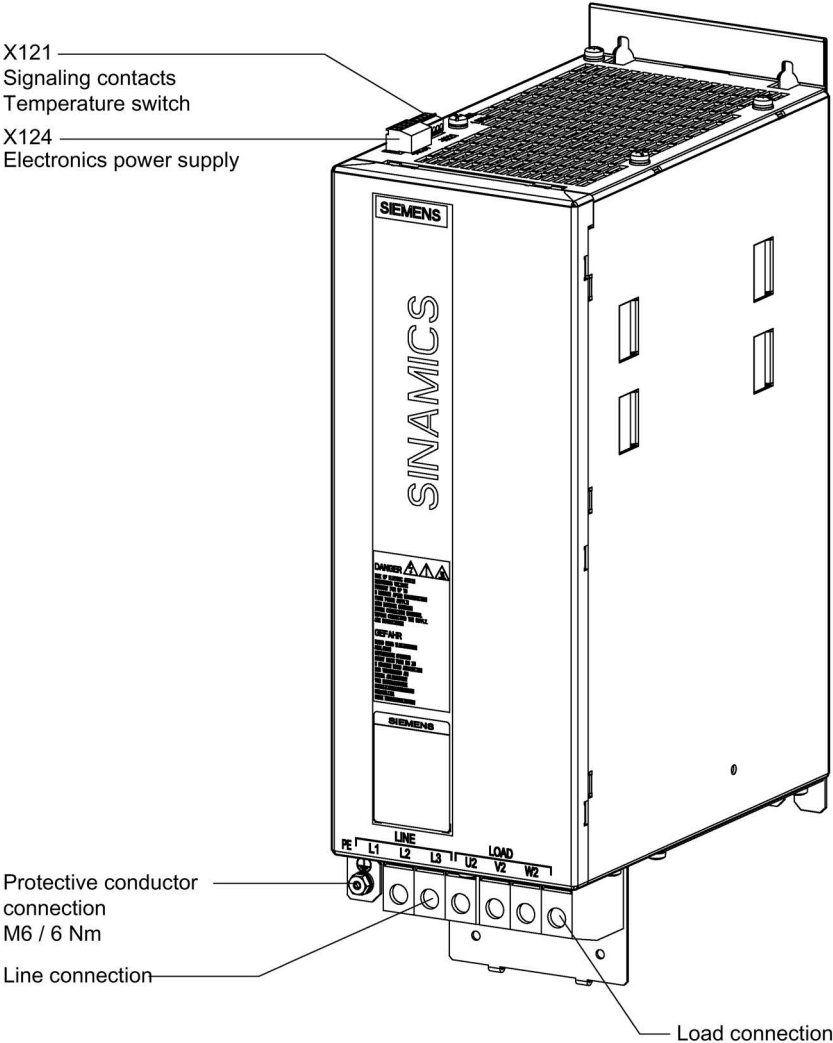

Figure 3-45 Interface overview, Active Interface Module 36 kW

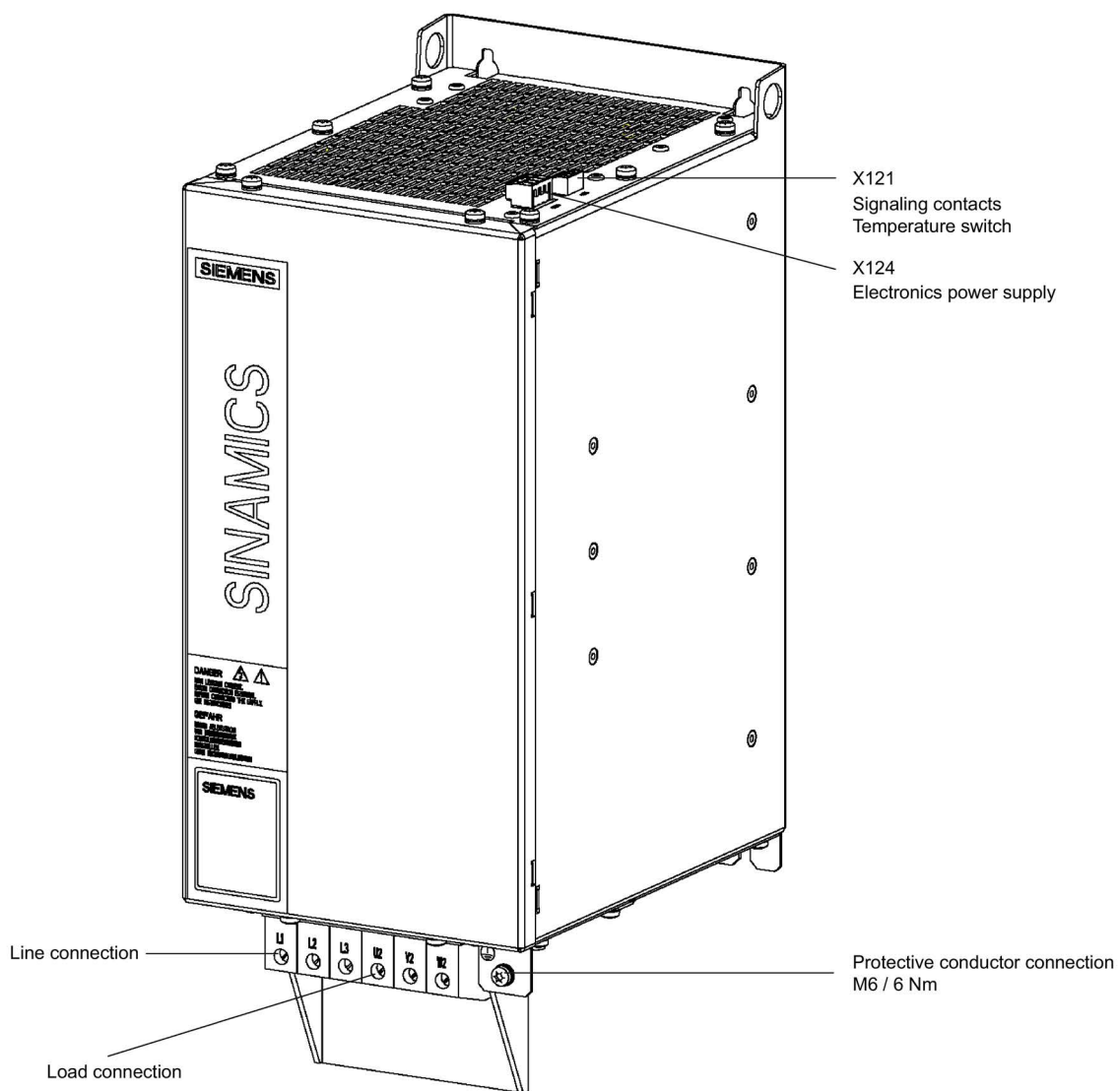

Figure 3-46 Interface overview, Active Interface Module 55 kW

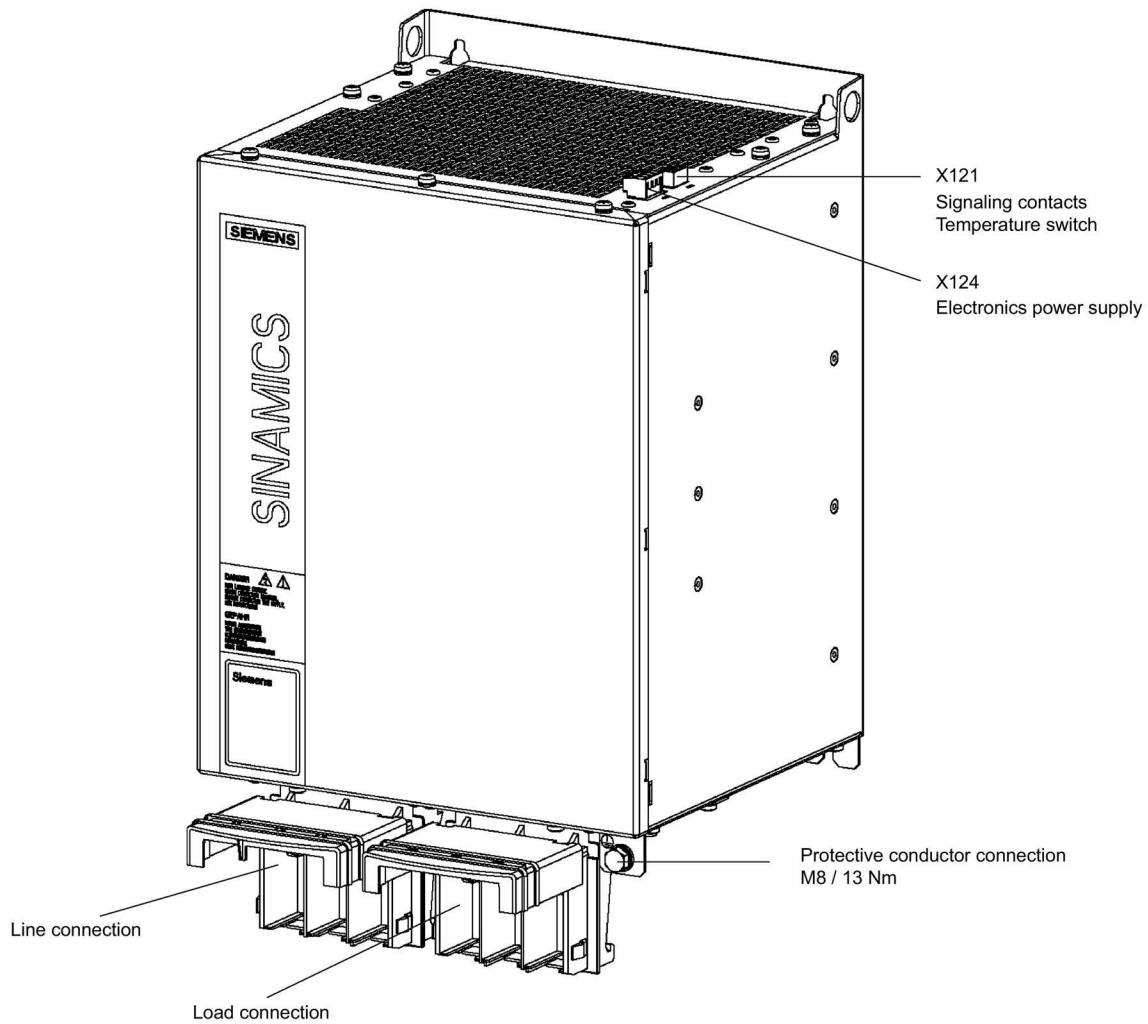

Figure 3-47 Interface overview, Active Interface Module 80 kW and 120 kW

3.8.3.2 Line/load connection

Table 3- 17 Line and load connection Active Interface Module

	6SL3100-0BE21-6AB.	6SL3100-0BE23-6AB.	6SL3100-0BE25-5AB.	6SL3100-0BE28-0AB.	6SL3100-0BE31-2AB.
Power	16 kW	36 kW	55 kW	80 kW	120 kW
Line connection L1, L2, L3	Screw terminal 16 mm ² (AWG 6), 1.7 Nm (15.0 lbf in)	Screw terminal 50 mm ² (AWG 1), wire end ferrule, 6 Nm (53.1 lbf in)	Screw terminal 50 mm ² (AWG 1), wire end ferrule, 6 Nm (53.1 lbf in)	Threaded bolt M8, cross-section 120 / 2 x 50 mm ² (AWG 4/0 / 2 x AWG 1), 13 Nm (AWG 115) ¹⁾	
Load connection U2, V2, W2					
Screwdrivers	1.0 x 4	1.2 x 6.5	1.2 x 8	-	
¹⁾ For ring cable lugs without insulation (Page 710)					

Note

Maintaining touch protection for Active Interface Modules 36 kW

The connection terminals of the 36 kW Active Interface Module are only certain to have touch protection IPXXB according to IEC 60529, if cables with a minimum cross-section of 25 mm² (AWG 4) and insulated end sleeves are used.

3.8.3.3 X121 temperature sensor and fan control

Table 3- 18 Plug-in screw terminal X121

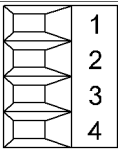
	Terminal	Designation	Technical data
	1	+Temp	Output temperature switch Must be connected to interface X21 of the Active Line Module.
	2	-Temp	Temperature switch output
	3	+24 V power supply for digital inputs	Current carrying capacity: 500 mA
	4	Disable Fan	The fan can be disabled. The fan may be disabled only while the Active Line Module is disabled.
Type: Screw terminal 1 (Page 708)			

Note

If terminal X121.4 is not connected (or connected with low level), the fan will run in the continuous mode.

3.8.3.4 X124 Electronics power supply

Table 3- 19 X124 Electronics power supply

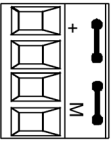
	Terminal	Function	Technical data
	+	Electronics power supply	Voltage: 24 VDC (20.4 ... 28.8 V) Current consumption: max. 1.6 A Max. current via jumper in connector: 20 A at 55° C
	+	Electronics power supply	
	M	Electronics ground	
	M	Electronics ground	

Type: Screw terminal 2 (Page 708)

Note

The two "+" and "M" terminals are jumpered in the connector. This ensures the supply voltage is looped through.

3.8.4 Connection example

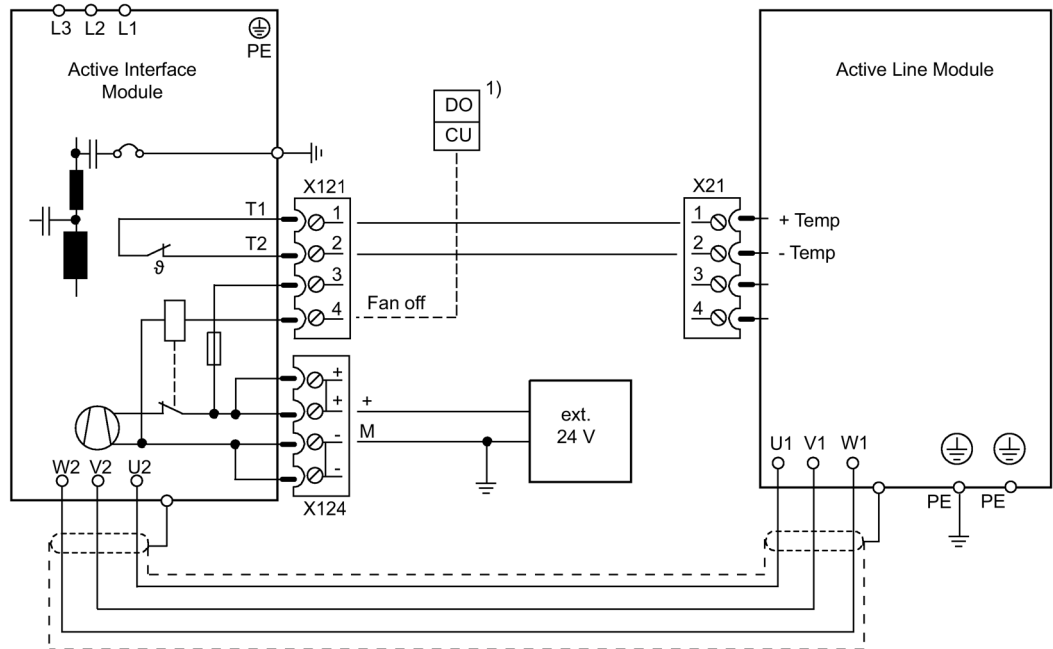

1) Digital output (DO), controlled by the Control Unit

Figure 3-48 Connection example: Active Interface Module

3.8.5 Dimension drawings

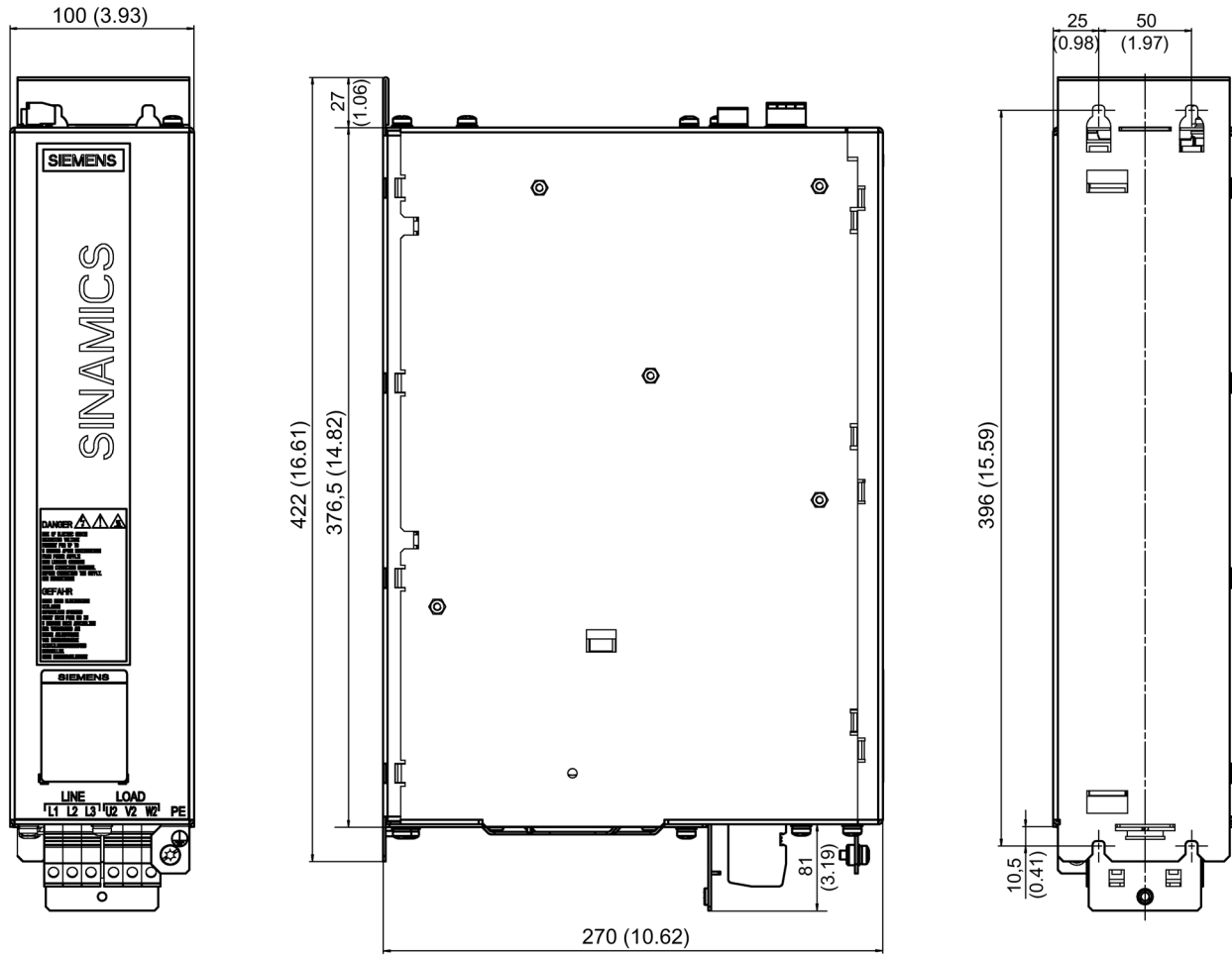

Figure 3-49 Dimension drawing of Active Interface Module 16 kW, all dimensions in mm and (inches)

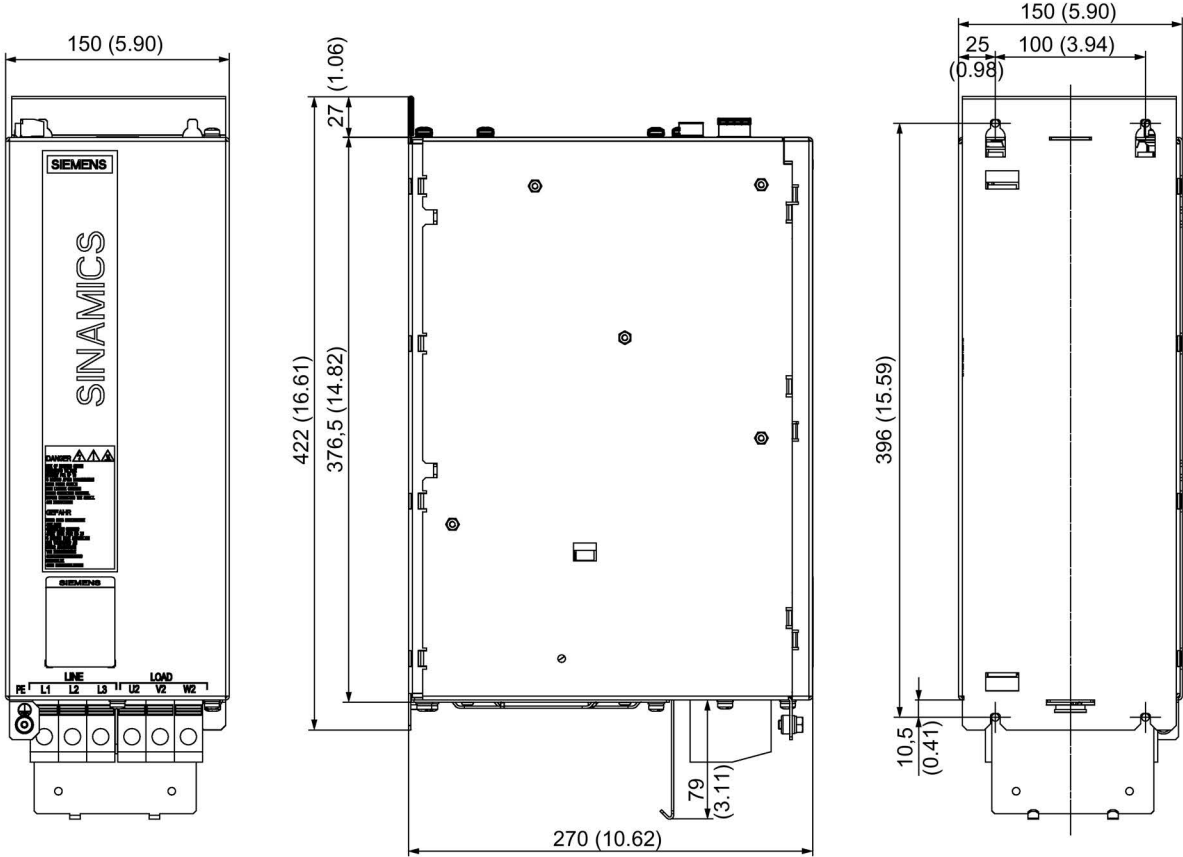

Figure 3-50 Dimension drawing of Active Interface Module 36 kW, all dimensions in mm and (inches)

3.8 Active Interface Modules internal air cooling

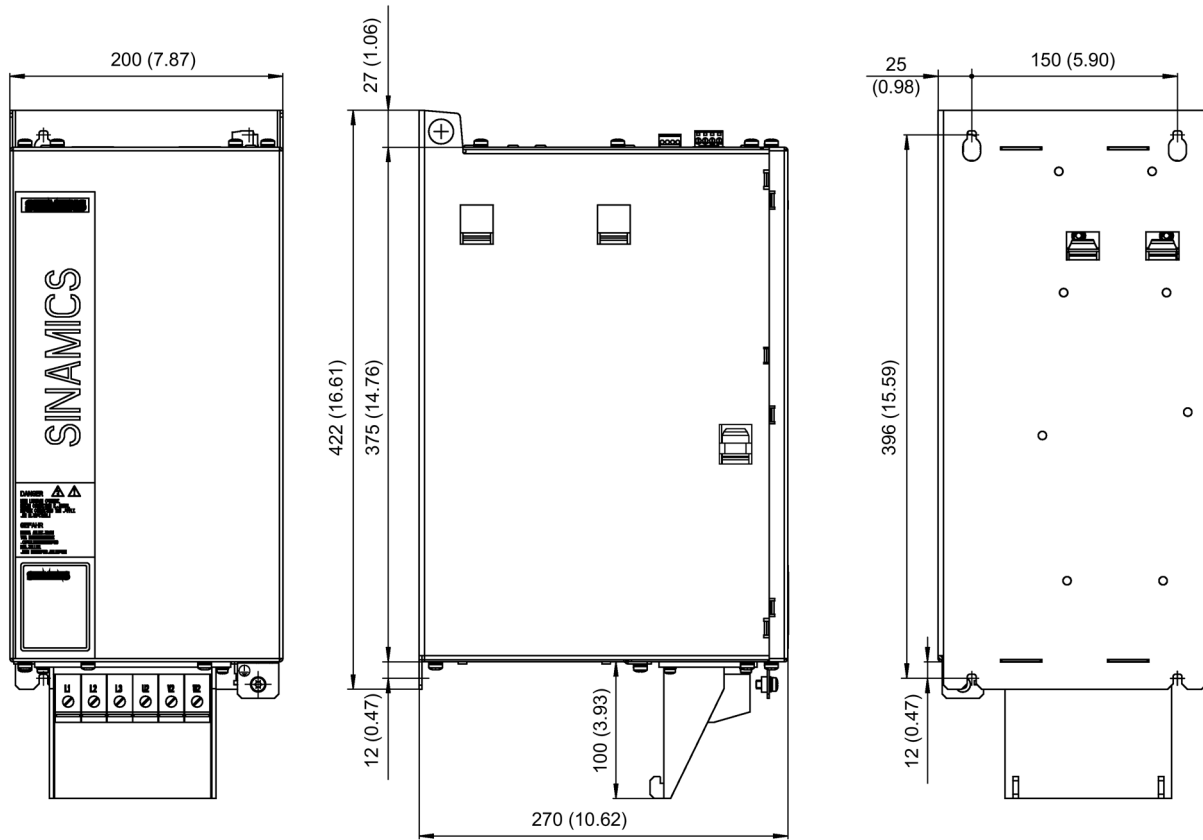

Figure 3-51 Dimension drawing of Active Interface Module 55 kW, all dimensions in mm and (inches)

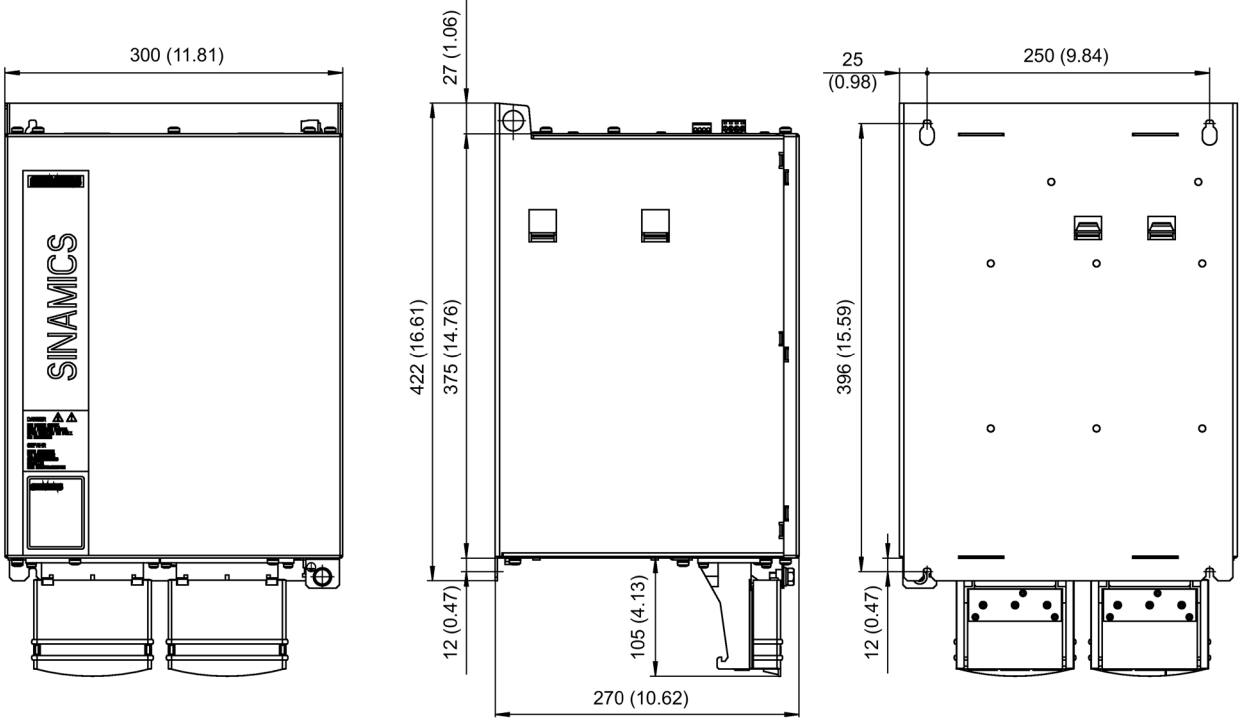
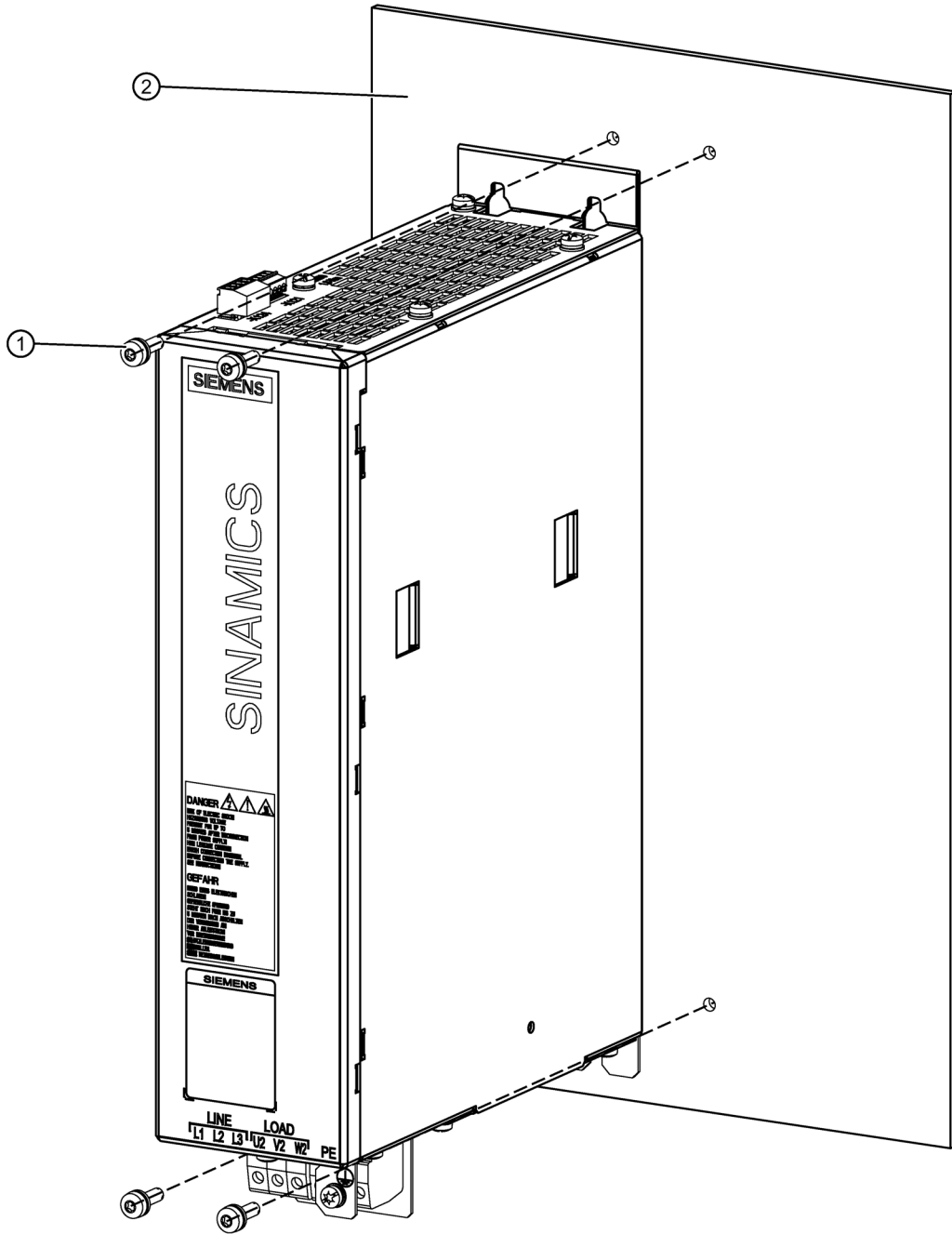

Figure 3-52 Dimension drawing of Active Interface Module 80 kW and 120 kW, all dimensions in mm and (inches)

3.8.6 Installation

The Active Interface Modules are designed for installation in the control cabinet. The Active Interface Modules should if possible be mounted directly next to the Active Line Module.



- ① M6 screw (no hexagon-head screw)
- ② Mounting panel

Figure 3-53 Installation of 16 kW Active Interface Module

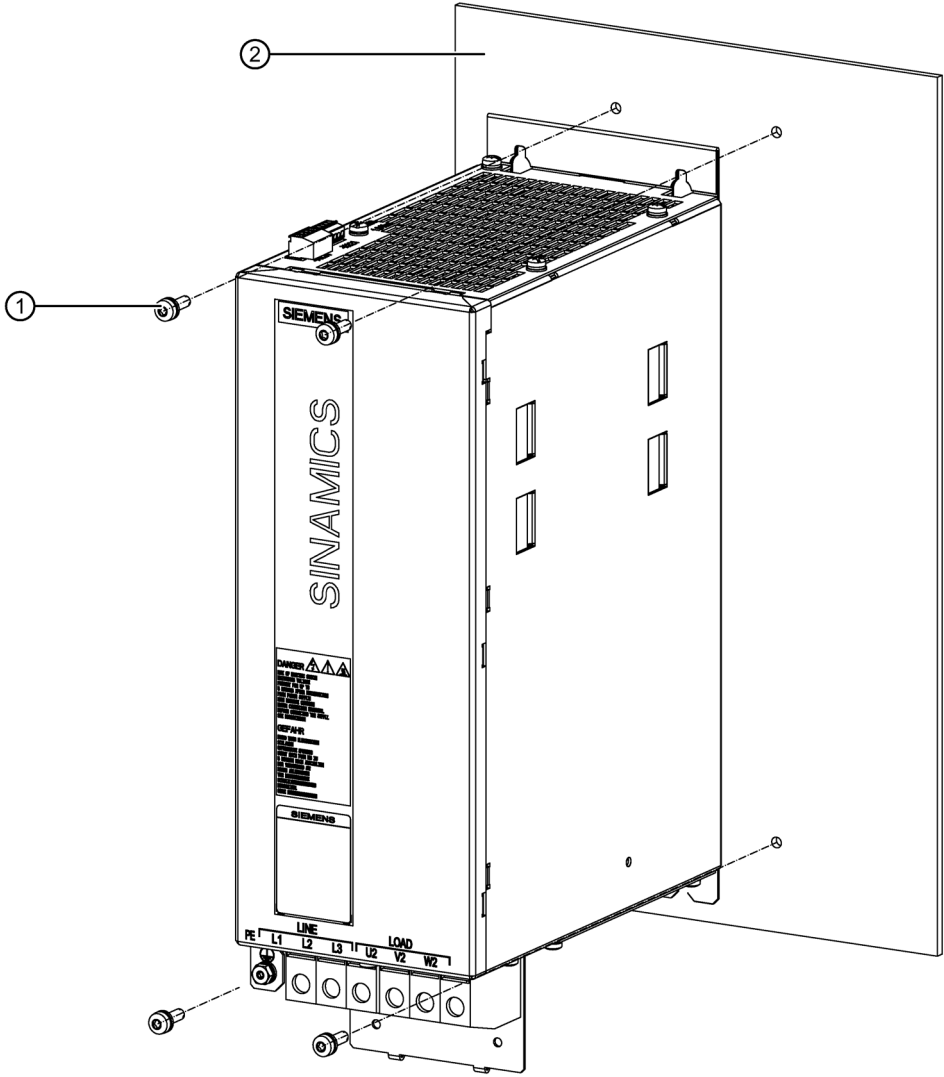

- ① M6 screw (no hexagon-head screw)
- ② Mounting panel

Figure 3-54 Installation of 36 kW Active Interface Module

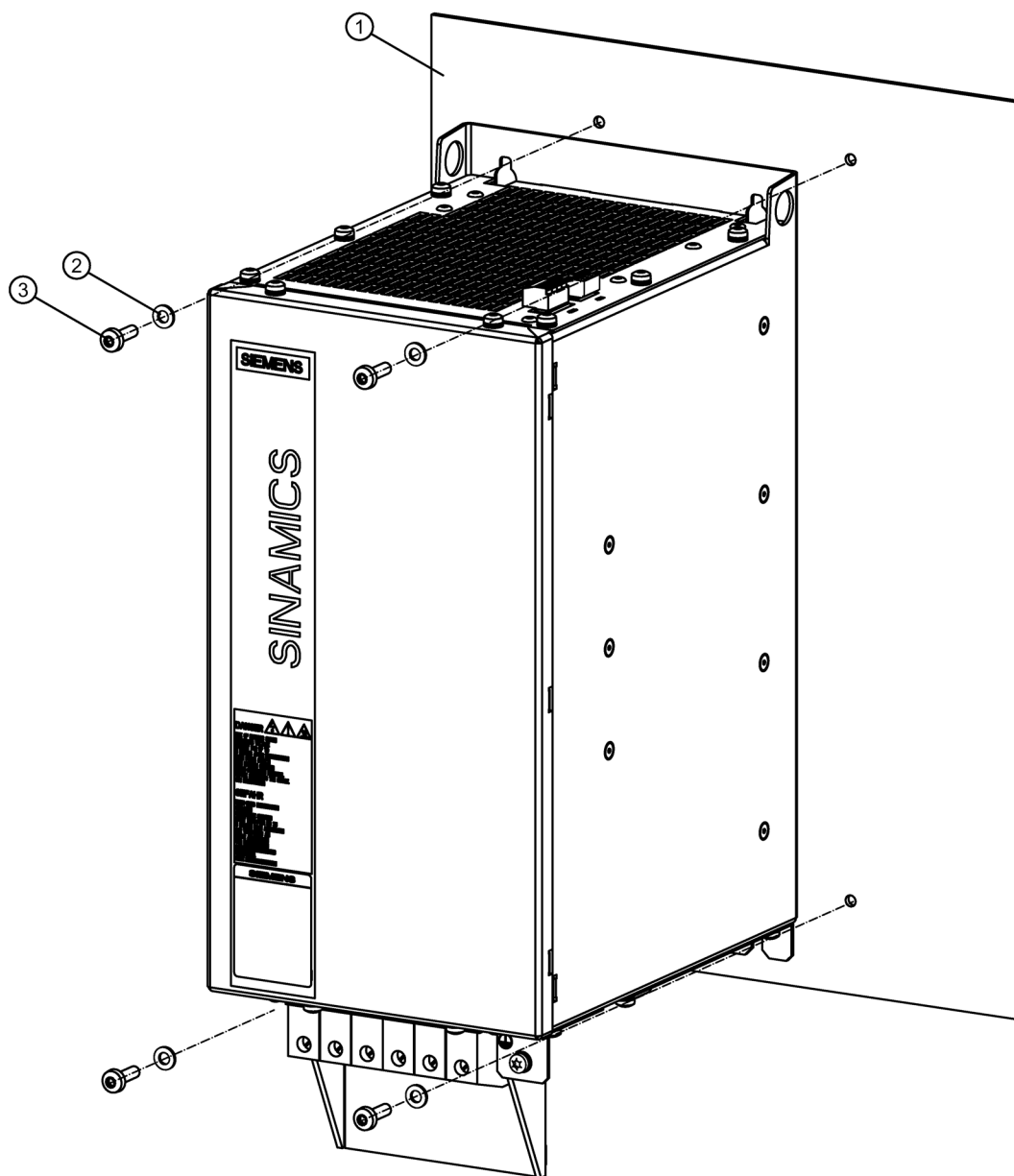

- ① Mounting panel
- ② Washer
- ③ M6 screw (no hexagon-head screw)

Figure 3-55 Installation of 55 kW Active Interface Module

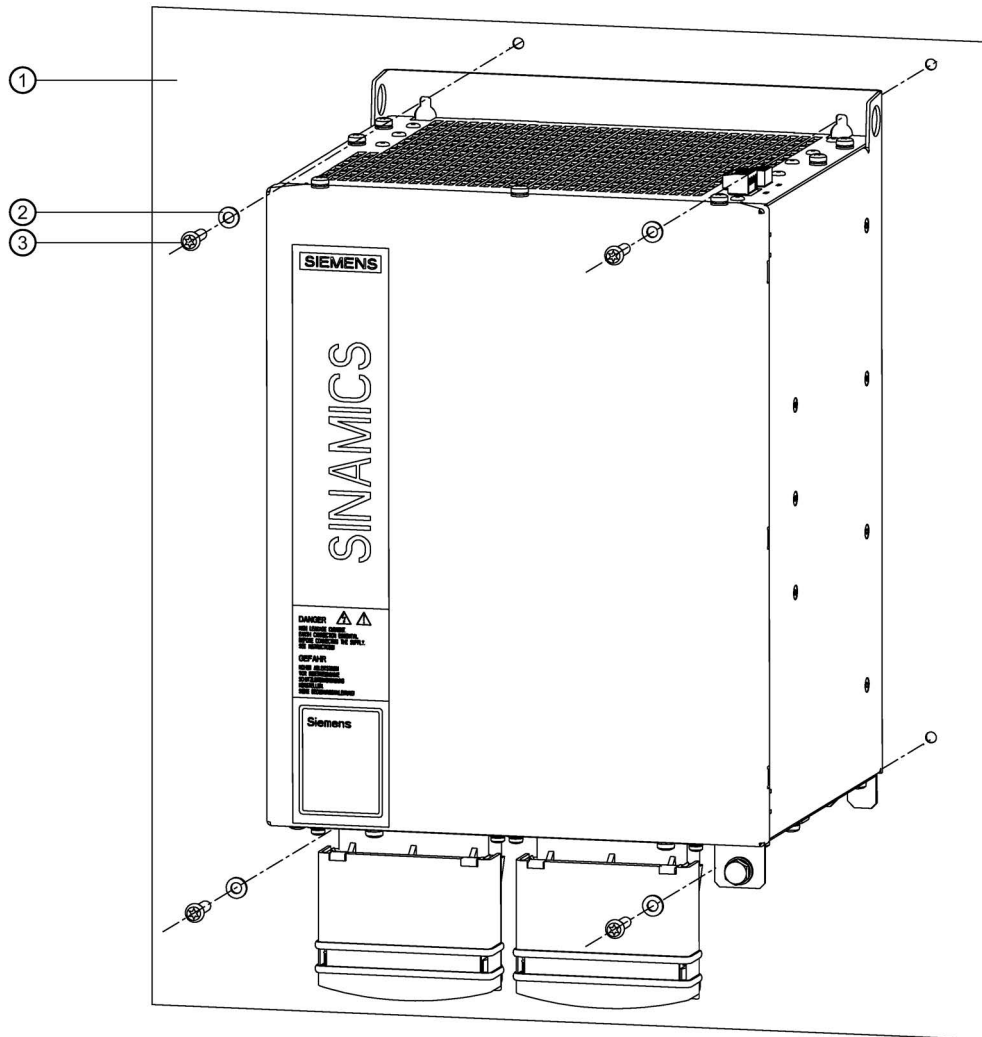

- ① Mounting panel
- ② Washer
- ③ M6 screw (no hexagon-head screw)

Figure 3-56 Installation of 80 kW or 120 kW Active Interface Module

Tightening torque for all screws: 6 Nm (53.1 lbf in)

Table 3- 20 Protective conductor connection

Active Interface Module	
16 kW	Threaded hole M5 / 3 Nm (26.6 lbf in)
36 / 55 kW	Threaded hole M6 / 6 Nm (53.1 lbf in)
80 / 120 kW	Threaded hole M8 / 13 Nm (115 lbf in)

3.8.7 Operation on an isolated-neutral system (IT system)

IT line system

In IT systems, all live parts are isolated from ground, or one point is connected to ground through an impedance. Housings of loads in the electrical plant or system are either individually grounded, jointly grounded or are all connected to the system ground.

Only Line Modules without a line filter are to be operated on this system type. The emitted interference can exceed the limit values of category C3. The Active Interface Module must be set for operation on an IT line system.

Operating an Active Interface Module on an isolated-neutral line supply (IT line supply)

Note

When an Active Interface Module is operated on an isolated-neutral line supply (IT system), the connecting screw for the interference suppression capacitor (Page 119) in the Active Interface Module must be removed. It is located on the lower side of the component.

If it is not removed, then the insulation monitor will respond.

Removing the connecting screw to the interference-suppression capacitor eliminates the effect of the filter with respect to ground. The symmetrical filter branch and the clock frequency filter remain effective.

3.8.8 Operation on networks with asymmetrical grounding

TN or TT systems with asymmetrical grounding are not grounded at the neutral point, but rather at another reference point, for example at the line conductor.

For operation in such networks, the connecting screw to the interference suppression capacitor (Page 119) must be removed.

The symmetrical filter branch and the clock frequency filter remain effective.

NOTICE
Damage to equipment if operation is carried out on asymmetrically grounded networks without the connecting screw removed
With asymmetrical grounding, the interference suppression capacitors are subjected to voltage overload if the connecting screw has not been removed.
<ul style="list-style-type: none">Remove the connecting screw to the interference suppression capacitor before commissioning.

3.8.9 Removing the connecting screw for the interference suppression capacitor



! WARNING

Electric shock when the connecting screw is removed

Because of the capacitors, a hazardous voltage is present at the connecting screw for up to 5 minutes after the power supply has been switched off.

Contact with live parts can result in death or serious injury.

- Wait 5 min. after the supply has been switched off before removing the connecting screw.

<p>AIM 16/36: Connecting screw on the top side</p>	<p>AIM 55/80/120: Connecting screw on the bottom side</p>	<p>Connecting screw for the interference suppression capacitor (M5x55)</p>
<p>Remove the connecting screw to the interference suppression capacitor using a Tx25 screwdriver.</p>		

Note

Insert the connecting screw to the interference suppression capacitor

For operation in other networks, the connecting screw must be reinserted and fixed with a tightening torque of 1.8 Nm (15.9 lbf in).

3.8.10 Technical data

Table 3- 21 Technical data

Active Interface Module	6SL3100-	0BE21-6AB.	0BE23-6AB.	0BE25-5AB.	0BE28-0AB.	0BE31-2AB.
		16 kW	36 kW	55 kW	80 kW	120 kW
P _{max}	kW	35	70	110	131	175
I _{rated}	A	26	58	88	128	192
I _{max}	A	59	117	176	218	292
Current requirement of the 24 V DC electronics power supply	A	0.25	0.6	0.6	1.2	1.2
Line voltage	V	3-phase 380°V...°480°VAC ±°10%				
Line frequency	Hz	47 ... 63				
Cooling air requirement	m³/h	112	160	300	600	600
Power loss ¹⁾ (see power loss tables (Page 734))	W	270	340	380	490	585
Weight	kg	13.0	18.5	23.2	31.9	36.6
Connection cross-section	mm²	10	35	50	120	120
Protective conductor terminal bolt		M5	M6	M6	M8	M8

1) Referred to U_{DC link} = 600 V

3.9 Combination options, Line Modules with line reactors and line filters

Table 3- 22 Combination options, Active Line Modules with line filters, line reactors and Active Interface Modules

ALM type					combined with:			Features that can be achieved					
16 kW	36 kW	55 kW	80 kW	120 kW	Filter / reactor / AIM			DC link step up factor or rectified value B6	Total cable length for radio interference suppression according to EN 61800-3				Can be operated on an IT system (C4)
					BLF	HFD	AIM		Cat. C2 shielded in m	Cat. C3 shielded in m	No compliance with limit value category		
						shielded in m	unshielded in m						
•	•	•	•	•		x		1.4 ... 1.6	-	-	350	560	Yes
•	•	•			x	x			150	150	350	560	No
•	•						x	1.4 ... 2 ²⁾	-	350	630	850	Yes ¹⁾
		•	•	•			x		-	350	1000	1500	Yes ¹⁾

ALM type					combined with:			Features that can be achieved					
16 kW	36 kW	55 kW	80 kW	120 kW	Filter / reactor / AIM			DC link step up factor or rectified value B6	Total cable length for radio interference suppression according to EN 61800-3				Can be operated on an IT system (C4)
					BLF	HFD	AIM		Cat. C2 shielded in m	Cat. C3 shielded in m	No compliance with limit value category		
											shielded in m	unshielded in m	
•	•				x		x		350	630	630	850	No
		•	•	•	x		x		350	1000	1000	1500	No

1) Remove connecting screw to the interference suppression capacitor

2) The motor insulation strength must be taken into account

Note

Ideally, new systems using Active Line Modules should be designed with Active Interface Modules as line connection components.

Table 3- 23 Combination options, Smart Line Modules with line filters and line reactors

SLM type					combined with:		Features that can be achieved					
5 kW	10 kW	16 kW	36 kW	55 kW	Filter/reactor		DC link step up factor or rectified value B6	Total cable length for radio interference suppression according to EN 61800-3				Can be operated on an IT system (C4)
					BLF	FE line reactor		Cat. C2 shielded in m	Cat. C3 shielded in m	No compliance with limit value category		
										shielded in m	unshielded in m	
•	•					x	1.35	-	-	350	560	Yes
		•	•	•		x		-	-	630	850	Yes
•	•				x	x		350	350	350	560	No
		•	•	•	x	x		350	630	630	850	No

3.9 Combination options, Line Modules with line reactors and line filters

Table 3- 24 Combination options, Basic Line Modules with line filters and line reactors

BLM type			combined with:		Features that can be achieved					
20 kW	40 kW	100 kW	Filter/reactor		DC link step up factor or rectified value B6	Total cable length for radio interference suppression according to EN 61800-3				Can be operated on an IT system (C4)
			BLF	FE line reactor		Cat. C2 shielded in m	Cat. C3 shielded in m	No compliance with limit value category		
		shielded in m			unshielded in m					
•	•			x	1.35	-	-	630	850	Yes
		•		x		-	350	1000	1500	Yes ¹⁾
•	•		x	x		350	630	630	850	No
		•	x	x		350	630	1000	1500	No

1) Remove connection bracket to the interference suppression capacitor

3.10 Line connection variants

3.10.1 Ways of connecting the line supply

Note

Permissible line supplies

In combination with the drive system, the motors are generally approved for operation on TN and TT line systems with grounded neutral point and on IT line systems.

A distinction is made between the following line connection versions:

- Line connection components to be directly connected to the line supply
- Operating line connection components via an autotransformer
- Operating line connection components via an isolating transformer



 WARNING
--

Electric shock if an isolating transformer is not used

To maintain safe electrical separation, for high voltages, an isolating transformer must be used.

- | |
|--|
| <ul style="list-style-type: none"> • Install an isolating transformer for voltages > 480 V +10%. |
|--|

 WARNING
--

Fire hazard for the motor due to overload of the insulation
--

There is higher stress on the motor insulation as a result of a ground fault in an IT line system or a line system with grounded line conductor.
--

TT line supply systems generally have a grounded line conductor.
--

A possible result is the failure of the insulation with a risk for personnel as a result of smoke and fire.

- | |
|---|
| <ul style="list-style-type: none"> • For IT line supplies, use a monitoring device that signals an insulation fault. • Correct the fault as quickly as possible in IT systems so the motor insulation is not overloaded. • For line supplies with grounded line conductor, use an isolating transformer with grounded neutral point (on the secondary) between the line supply and the drive system. |
|---|

3.10.2 Operating line connection components on the line supply

The SINAMICS S Booksize converter system is rated for direct operation on TN, TT, and IT line supply systems with a rated voltage of 380 V 3 AC to 480 V 3 AC.

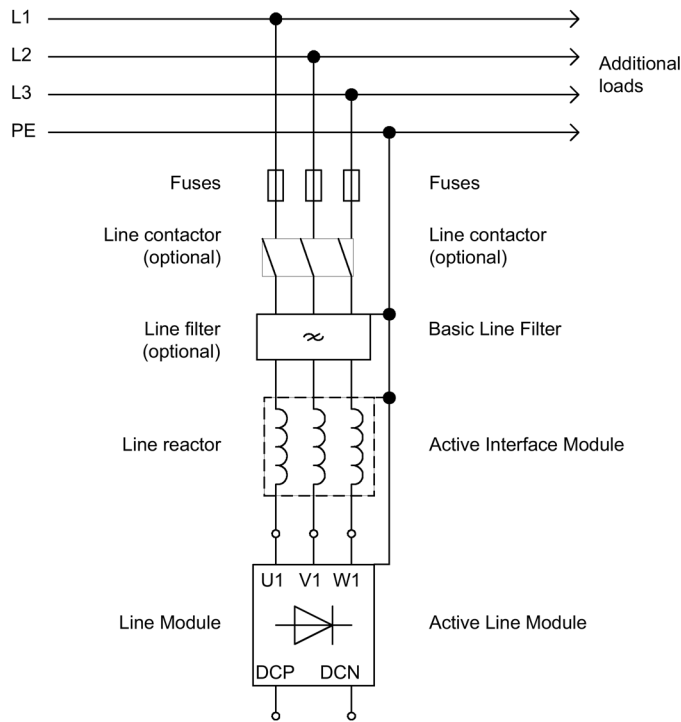

Figure 3-57 Direct operation on the line supply

3.10.3 Operation of the line connection components via a transformer

3.10.3.1 Safety instructions for line connection components



! WARNING

Electric shock or fire due to overcurrent protective equipment that trips too late or not at all

Overcurrent protective equipment that trips too late or not at all can cause electric shock or fire.

- In the case of a conductor-conductor or conductor-ground short-circuit, ensure that the short-circuit current at the point where the converter is connected to the line supply corresponds as a minimum to the requirements of the protective equipment used.
- It is not permissible that the short-circuit current exceeds the SCCR or the I_{cc} of the converter and the disconnecting capacity of the protective equipment.
- You must additionally use a residual-current protective device (RCD) if, for a conductor-ground short circuit, the required short-circuit current is not reached. Especially for TT systems, the required short-circuit current cannot be attained.

NOTICE

Destruction or damage to additional loads as a result of undesirable line harmonics

Line harmonics can occur if line filters that differ from those listed in this manual are used. These can destroy or damage other loads connected to the line supply.

- Only use line filters that are listed in this Manual.

NOTICE

Destruction or damage to additional loads as a result of incorrect connection

When incorrectly connecting the line filter, other loads can be destroyed or damaged.

- Connect additional loads upstream of the SINAMICS line filter (if required, via a separate line filter).

Note

If, for Line Modules, a transformer is used, this does not replace the external line reactor.

3.10.3.2 Line supply connection conditions for Line Modules

Table 3- 25 Line supply connection conditions for Line Modules

Module	Description ¹⁾
Basic Line Module	Operation on line supplies from $S_{K\ line}/P_n \geq 30$
Smart Line Module	Operation on line supplies from $S_{K\ line}/P_n \geq 70$
Active Line Modules with Active Interface Modules	Operation on line supplies from $S_{K\ line}/P_n \geq 30$ ²⁾
Active Line Module	Operation on line supplies from $S_{K\ line}/P_n \geq 70$

1) $S_{K\ line}$ = short-circuit power of the line supply; P_n = rated power of the Line Module

2) Applies only for operation in the active mode. For line supplies 3-ph 480 VAC $\pm 10\%$, it must be checked as to whether the motor systems are suitable for this mode.

If a TN line supply is specified on the secondary side, then a transformer with grounded neutral point must be used. However, the loop resistance must be small enough to trigger the fuses as fast as required. Also see Chapter Overcurrent protection using line fuses and circuit breakers (Page 47).

Note

System fault level at the infeed point

In order to comply with EMC limit values, Category C2 according to EN 61800-3, the system fault level at the infeed point must be at least a factor 70 higher than the rated power of the integrated infeed.

Vector group

Any vector group with the neutral point brought out on the secondary side.

3.10.3.3 Dimensioning an isolating transformer / autotransformer for several loads

A SINAMICS Line Module and other loads/machines should be connected via an isolating transformer / autotransformer (matching transformer) to the line supply. The following diagram shows the connection using an isolating transformer as an example.

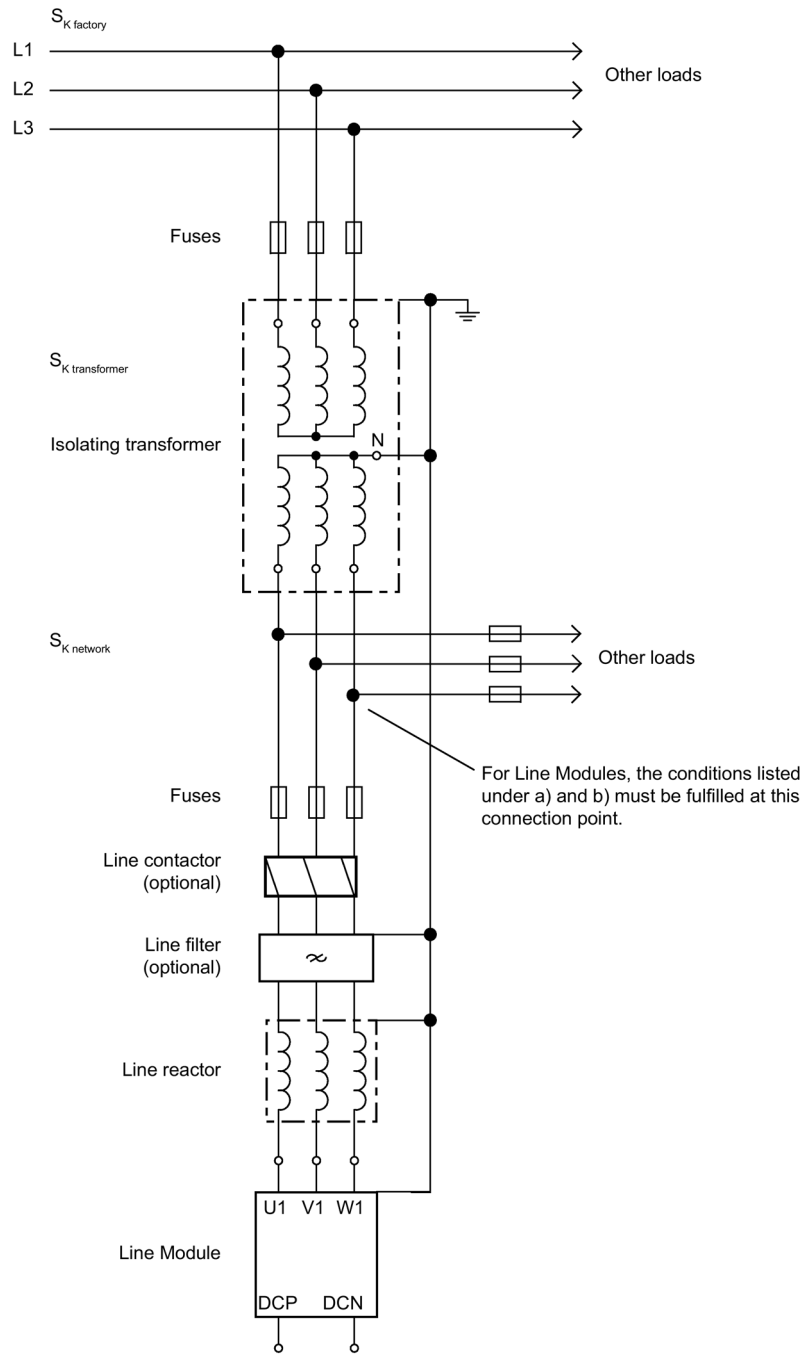

Figure 3-58 Operation of a Line Module and additional loads via an isolating transformer

3.10 Line connection variants

An isolating transformer / autotransformer (matching transformer) must be dimensioned for the total of all loads connected to it. The apparent power required for the Line Modules must be determined and added as indicated in table "Transformer configuration instructions". If the transformer is underdimensioned (S_n or S_k), this can lead to increased line voltage dips and faults in the line supply and in other loads at this connecting point.

If other loads are connected to the secondary side of the matching transformer, the boundary conditions indicated under a) and b) must be complied with when selecting the matching transformer.

S_{n1}, S_{n2} = calculated rated power of the transformer resulting from a) and b)

u_k = short-circuit voltage of the matching transformer in %
(must be between 1% and 3% for Active Line Modules and Smart Line Modules)

S_k = short-circuit power.

Supplementary condition

Limitation a)

The rated power of the matching transformer S_{n1} must as a minimum always be a factor of 1.27 higher than the rated power P_n of the Line Module.

$$S_{n1} \geq 1.27 \cdot P_n$$

Example:

The minimum rated power of a matching transformer for a 16 kW Line Modules is 21 kVA.

Limitations b)

In order to avoid faults and disturbances at the other loads that are connected to the secondary side of the matching transformer, the short-circuit power of the plant connection ($S_{k \text{ factory}}$) and that of the matching transformer at the connection point ($S_{k \text{ line}}$) must reach at least the following values.

$$S_{k \text{ line}} \geq 70 \cdot P_n \text{ (for Active Line Module and Smart Line Module)}$$

$$S_{k \text{ line}} \geq 30 \cdot P_n \text{ (for Basic Line Module)}$$

Special case:

When operating with only one supply at a transformer, the values may be reduced to a factor 0.73.

$$S_{k \text{ line}} \geq 0.73 \cdot 70 \cdot P_n \text{ (for Active Line Module and Smart Line Module)}$$

$$S_{k \text{ line}} \geq 0.73 \cdot 30 \cdot P_n \text{ (for Basic Line Module)}$$

For example $S_{k \text{ line}}$ for 16 kW Active Line Module: $S_{k \text{ line}} = 0.82 \text{ MVA} = 820 \text{ kVA}$

The required rated power of the matching transformer can be calculated with the following formula.

$$S_{n2} = \frac{S_{k \text{ factory}} [\text{kVA}] + S_{k \text{ line}} [\text{kVA}] \cdot u_k [\%]}{(S_{k \text{ factory}} [\text{kVA}] - S_{k \text{ line}} [\text{kVA}]) \cdot 100 [\%]} \quad [\text{kVA}]$$

Note:

The short-circuit power at the plant connection $S_{K \text{ factory}}$ plays a decisive role in dimensioning the matching transformer.

From the rated power (S_{n1} or S_{n2}) calculated under a) and b), the higher value must be used for the matching transformer.

Table 3- 26 Engineering information for transformers for Active Line Modules

Rated power P_n	Required rated power of the isolating transformer / auto-transformer $S_n (1.27 \cdot P_n)$	Required short-circuit voltage U_k	Minimum system fault level required $S_{K \text{ line}} (70 \cdot P_n)$
16 kW	≥ 21 kVA	≤ 3 %	≥ 1.12 MVA
36 kW	≥ 46 kVA	≤ 3 %	≥ 2.52 MVA
55 kW	≥ 70 kVA	≤ 3 %	≥ 3.85 MVA
80 kW	≥ 102 kVA	≤ 3 %	≥ 5.6 MVA
120 kW	≥ 153 kVA	≤ 3 %	≥ 8.4 MVA

Table 3- 27 Engineering information for transformers for Smart Line Modules

Rated power P_n	Required rated power of the isolating transformer / auto-transformer $S_n (1.27 \cdot P_n)$	Required short-circuit voltage U_k	Minimum system fault level required $S_{K \text{ line}} (70 \cdot P_n)$
5 kW	≥ 6.4 kVA	≤ 3 %	≥ 0.35 MVA
10 kW	≥ 13 kVA	≤ 3 %	≥ 0.7 MVA
16 kW	≥ 21 kVA	≤ 3 %	≥ 1.12 MVA
36 kW	≥ 46 kVA	≤ 3 %	≥ 2.52 MVA
55 kW	≥ 70 kVA	≤ 3 %	≥ 3.85 MVA

Table 3- 28 Engineering information for transformers for Basic Line Modules

Rated power P_n	Required rated power of the isolating transformer / auto-transformer $S_n (1.27 \cdot P_n)$	Required short-circuit voltage U_k	Minimum system fault level required $S_{K \text{ line}} (30 \cdot P_n)$
20 kW	≥ 26 kVA	$\leq 10\%$	≥ 0.6 MVA
40 kW	≥ 51 kVA	$\leq 10\%$	≥ 1.2 MVA
100 kW	≥ 127 kVA	$\leq 10\%$	≥ 3.0 MVA

Note

Ask your local power utility company for the short-circuit power at the plant connection $S_{K \text{ factory}}$.

Example 1

u_k matching transformer = 3 %
 $S_{K \text{ factory}} = 50000 \text{ kVA}$
 $S_{K \text{ line}} = 16 \text{ kW} \cdot 70 \cdot 0.73 = 820 \text{ kVA}$

According to a)
 $S_{n1} = 1.27 \cdot 16 \text{ kW} = 21 \text{ kVA}$

According to b)

$$S_{n2} = \frac{50000 \text{ kVA} \cdot 820 \text{ kVA} \cdot 3 \%}{(50000 \text{ kVA} - 820 \text{ kVA}) \cdot 100\%} = 25 \text{ kVA}$$

$S_{n2} > S_{n1} \Rightarrow S_{n2}$ is decisive.
The matching transformer requires a rated power S_n of 25 kVA for a short-circuit voltage u_k of 3%.

Example 2:

u_k matching transformer = 1 %
 $S_{K \text{ factory}} = 50000 \text{ kVA}$
 $S_{K \text{ line}} = 16 \text{ kW} \cdot 70 \cdot 0.73 = 820 \text{ kVA}$

According to a)
 $S_{n1} = 1.27 \cdot 16 \text{ kW} = 21 \text{ kVA}$

According to b)

$$S_{n2} = \frac{50000 \text{ kVA} \cdot 820 \text{ kVA} \cdot 1 \%}{(50000 \text{ kVA} - 820 \text{ kVA}) \cdot 100\%} = 8.3 \text{ kVA}$$

$S_{n1} > S_{n2} \Rightarrow S_{n1}$ is decisive.
The matching transformer requires a rated power S_n of 21 kVA for a short-circuit voltage u_k of 1%.

Example 3:

If $S_{K \text{ factory}}$ is smaller, the transformer must be stronger.

u_k matching transformer = 3 %
 $S_{K \text{ factory}} = 3000 \text{ kVA}$
 $S_{K \text{ line}} = 16 \text{ kW} \cdot 70 \cdot 0.73 = 820 \text{ kVA}$

According to a)
 $S_{n1} = 1.27 \cdot 16 \text{ kW} = 21 \text{ kVA}$

According to b)

$$S_{n2} = \frac{3000 \text{ kVA} \cdot 820 \text{ kVA} \cdot 3 \%}{(3000 \text{ kVA} - 820 \text{ kVA}) \cdot 100\%} = 33.9 \text{ kVA}$$

$S_{n2} > S_{n1} \Rightarrow S_{n2}$ is decisive
The matching transformer requires a rated power S_n of 34 kVA for a short-circuit voltage u_k of 3%.

Example 4:

If $S_{K \text{ factory}}$ is lower, you can use, alternatively to example 3, a transformer with a lower u_k .

$u_k \text{ matching transformer} = 1\%$,

$S_{K \text{ factory}} = 3000 \text{ kVA}$

$S_{K \text{ line}} = 16 \text{ kW} \cdot 70 \cdot 0.73 = 820 \text{ kVA}$

According to a)

$S_{n1} = 1.27 \cdot 16 \text{ kW} = 21 \text{ kVA}$

According to b)

$$S_{n2} = \frac{3000 \text{ kVA} \cdot 820 \text{ kVA} \cdot 1\%}{(3000 \text{ kVA} - 820 \text{ kVA}) \cdot 100\%} = 11.3 \text{ kVA}$$

$S_{n1} > S_{n2} \Rightarrow S_{n1}$ is decisive

The matching transformer requires a rated power S_n of 21 kVA for a short-circuit voltage u_k of 1%.

Note

S_{n2} for the matching transformer can be reduced by reducing u_k . In the examples above, the power drawn from other loads has not been taken into account.

3.10.3.4 Operating line connection components via an autotransformer

An autotransformer can be used to step up or step down the voltage in the range up to 3-ph. 480 VAC +10%.

Applications:

- The motor insulation must be protected from excessive voltages.
- The Active Line Module must supply a regulated DC link voltage. This is possible with a rated voltage of 380 V to 415 V.
In conjunction with motors that may be operated with a DC link voltage of up to 660 V, and a line voltage > 415 V, a controlled DC link voltage is required.

3.10 Line connection variants

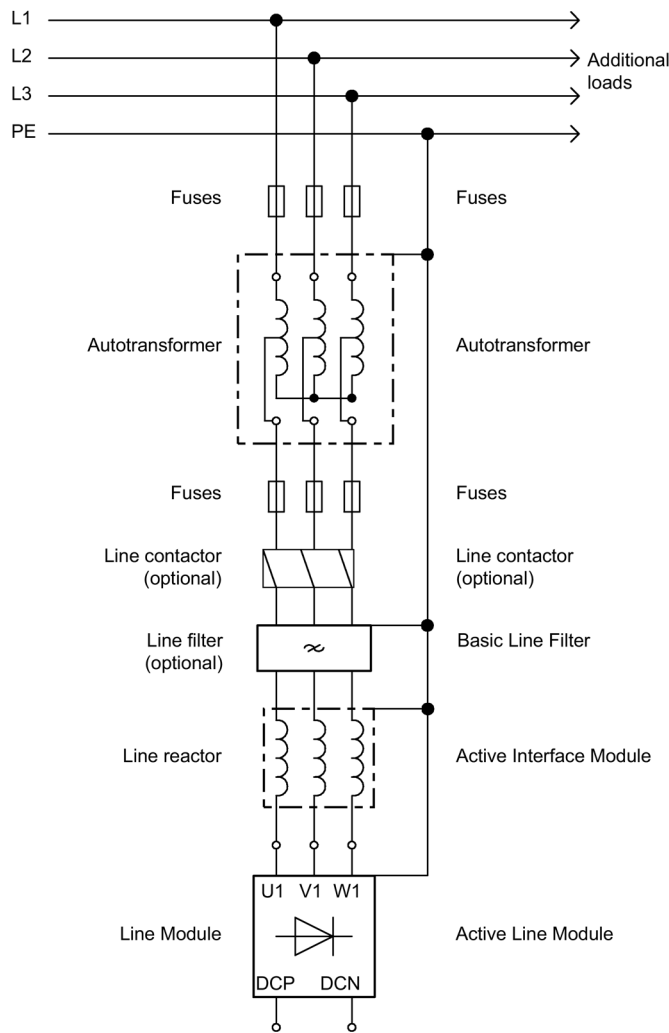

Figure 3-59 Operation of a Line Module via an autotransformer

3.10.3.5 Operating line connection components via an isolating transformer

An isolating transformer converts the line supply type of the plant or system (e.g. IT system) to a TN system. Additional voltage adaptation to the permissible voltage tolerance range is possible.

An isolating transformer must be used in the following cases:

- The insulation of the Motor Module and/or the motor is not suitable for the voltages that occur.
- There is no compatibility with an existing residual-current protective device.
- The installation altitude is greater than 2000 m above sea level, and no TN or TT line system with grounded neutral point is used.
- A line filter should be used in a line supply system that is not a TN line supply system with grounded neutral conductor.

An isolating transformer must have the following properties:

- On the secondary side, the transformer must have a star connection.
- The neutral point must be brought out.

Recommended vector group: Dyn5 or Yyn0

The neutral point must be grounded and connected to the protective conductor connections of the line filter, line reactor or AIM and Line Module (infeed).

Comment: If the neutral point is not brought out and/or not connected, then all of the restrictions of an IT line system apply.

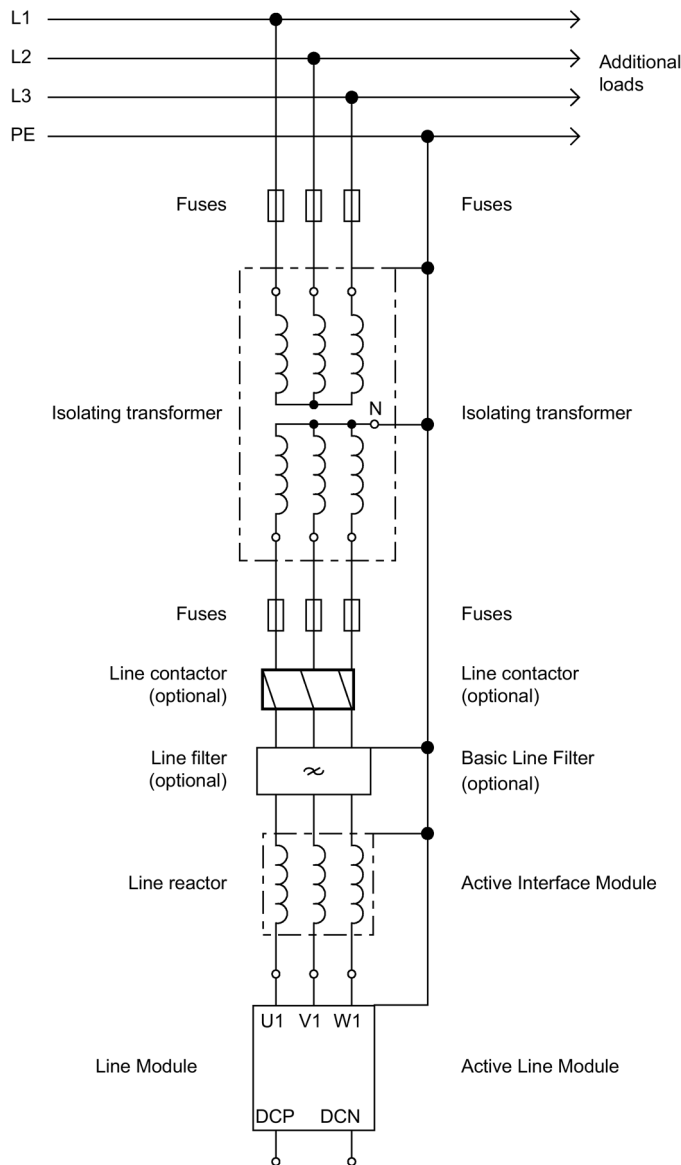

Figure 3-60 Operation of a Line Module via an isolating transformer

Line Modules Booksize

4.1 Safety instructions for Line Modules Booksize



! WARNING

Electric shock due to a high DC-link voltage

As long as the Line Module is connected to the line supply, the DC link is charged with a high voltage. A hazardous voltage can be present independent of the status of the LED "DC LINK" Contact with live parts and components can result in death or severe injury.

- Isolate the Line Module from the line supply during installation or maintenance work, e.g. via the line contactor or main switch.
- Observe the warning information on the component.



! WARNING

Electric shock due to the residual charge of the DC-link capacitors

Because of the DC link capacitors, a hazardous voltage is present for up to 5 minutes after the power supply has been switched off.

Contact with live parts can result in death or serious injury.

- Do not open the protective cover of the DC link until 5 minutes have elapsed.
- Measure the voltage before starting work on the DCP and DCN DC link terminals.



! WARNING

Electric shock when the protective cover of the DC link is open

Contact with live parts can result in death or serious injury.

- Only operate the components with closed protective cover.



! WARNING

Electric shock or fire due to overcurrent protective equipment that trips too late

Overcurrent protective equipment that trips too late or not all can cause electric shock or fire.

- To protect personnel and for fire protection purposes, at the infeed point, the short-circuit rating and loop impedance must match the specifications in the documentation so that the installed overcurrent protection devices trip within the specified time.



! WARNING

High leakage currents when the protective conductor in the line feeder cable is interrupted

The drive components conduct a high leakage current via the protective conductor. Touching conductive parts when the protective conductor is interrupted can result in death or serious injury.

- Carefully comply with the applicable regulations for dimensioning the protective conductor (see Chapter "Protective connection and equipotential bonding (Page 714)").



! WARNING

Electric shock due to improper DC link connection

Incorrect connections can cause overheating and so fire and smoke development. There is also a risk of an electric shock. This can result in serious injury or death.

- Only use adapters (DC link adapters and DC link rectifier adapters) released by Siemens for the connection to the DC link.



! WARNING

Electric shock due to incorrectly installed DC link bridges

Incorrectly installed DC link bridges **at the left-hand end of the drive line-up** can cause an electric shock.

- For all 50 mm wide modules¹⁾ (exception: Smart Line Module²⁾), remove the DC link bridge, including the screws. Do not tighten the screws without the DC link bridges.
- For all components that are 75 mm wide or wider, the DC link bridges may neither be swung over to the left nor removed³⁾.

¹⁾ For 50 mm wide modules, the DC link bridge cannot be swung inwards.

²⁾ Smart Line Modules do not have a DC link bridge.

³⁾ The DC link bridge guarantees the mechanical stability of the DC link busbars.





! WARNING

Electric shock due to missing DC-link side covers

Live parts are exposed if the DC link side covers are not fitted. Contact with these live parts could cause an electric shock.

- Mount the side covers on the first and last component in the drive line-up.
- Order any missing side covers (Article number: 6SL3162-5AA00-0AA0).

 WARNING
Fire due to overheating when the required cable cross-sections of power cables is fallen below
Power cables with excessively low cross-sections can cause them to overheat. This can result in severe injury or death due to fire and smoke.
<ul style="list-style-type: none"> • Only use power cables with sufficiently large cross-sections. Take into account the routing type, ambient temperature and cable length.

 WARNING
Fire due to overheating when the total length of the power cables is exceeded
Overheating can result when the total length of the power cables is exceeded. This can result in severe injury or death due to fire and smoke.
<ul style="list-style-type: none"> • Ensure that the total length of all power cables (motor supply cables and DC link cables) does not exceed the values specified in Section Combination options, Line Modules with line reactors and line filters (Page 120).

NOTICE
Damage through use of incorrect DRIVE-CLiQ cables
Damage or malfunctions can occur on the devices or system when DRIVE-CLiQ cables are used that are either incorrect or have not been approved for this purpose.
<ul style="list-style-type: none"> • Only use suitable DRIVE-CLiQ cables that have been approved by Siemens for the particular application.

Note**Operation on line supplies where energy recovery is not possible**

In line supply systems without energy recovery capability (e.g. a diesel generator), device faults can occur as the braking energy cannot be dissipated.

- Deactivate the energy recovery function of the Active Line Modules and Smart Line Modules using parameter p3533.
- The braking energy must then be dissipated via an additional Braking Module with braking resistor in the drive line-up.

Exception: For 5 kW and 10 kW Smart Line Modules, you must deactivate the energy recovery function as follows:

- Jumper between terminals X22.1 and X22.2
- Ground at X22.4

Note

Malfunctions due to polluted DRIVE-CLiQ interfaces

Malfunctions can occur in the system through the use of polluted DRIVE-CLiQ interfaces.

- Cover unused DRIVE-CLiQ interfaces with the supplied blanking covers.
-

Special features for Line Modules with external air cooling

Note

Component failure due to the pollution of external heat sinks

For components with external air cooling, the fan and the heat sinks can accumulate a lot of pollution. If the cooling air requirement is not provided by the filtered fan, the components cannot output their specified power. This can cause the temperature monitoring function in the components to respond.

- Check the fans and heat sinks for pollution at regular intervals and clean them when necessary.
-

Note

Checking the seal

- After installation, check the seal on the rear of the device to ensure that it is tight.
 - If required, use additional sealing.
-

Note

Using an installation frame

- Only use an installation frame when the cabinet has an unpainted metal surface.
-

4.2 Frequency with which the DC link is precharged

The frequency with which the DC link capacitance is precharged via the Line Module is determined using the following formula:

$$\text{Number of pre-charging operations within 8 minutes} = \frac{\text{Max. permissible DC link capacitance Line Module in } \mu\text{F}}{\Sigma \text{DC link capacitance of the configured drive line-up in } \mu\text{F}}$$

The DC link capacitances of the individual components can be taken from the relevant technical data.

4.3 Active Line Modules with internal air cooling

4.3.1 Description

Active Line Modules generate a constant, regulated DC voltage in the DC link from the 3-phase line supply voltage that supplies the connected Motor Modules with power.

This ensures that they are not influenced by line voltage fluctuations.

When motors brake, Active Line Modules feed energy back into the line supply. The regenerative feedback capability of the modules can be deactivated by parameterization.

The DC link starts precharging as soon as the line voltage is applied and is independent of its phase sequence direction. Load can be applied to the DC link after the module has been enabled.

A line contactor can be installed on the line side if the system has to be electrically isolated from the line supply.

Active Line Modules can be directly connected to TN, IT and TT systems. The Line Modules have an integrated overvoltage protection function.

4.3.2 Interface description

4.3.2.1 Overview

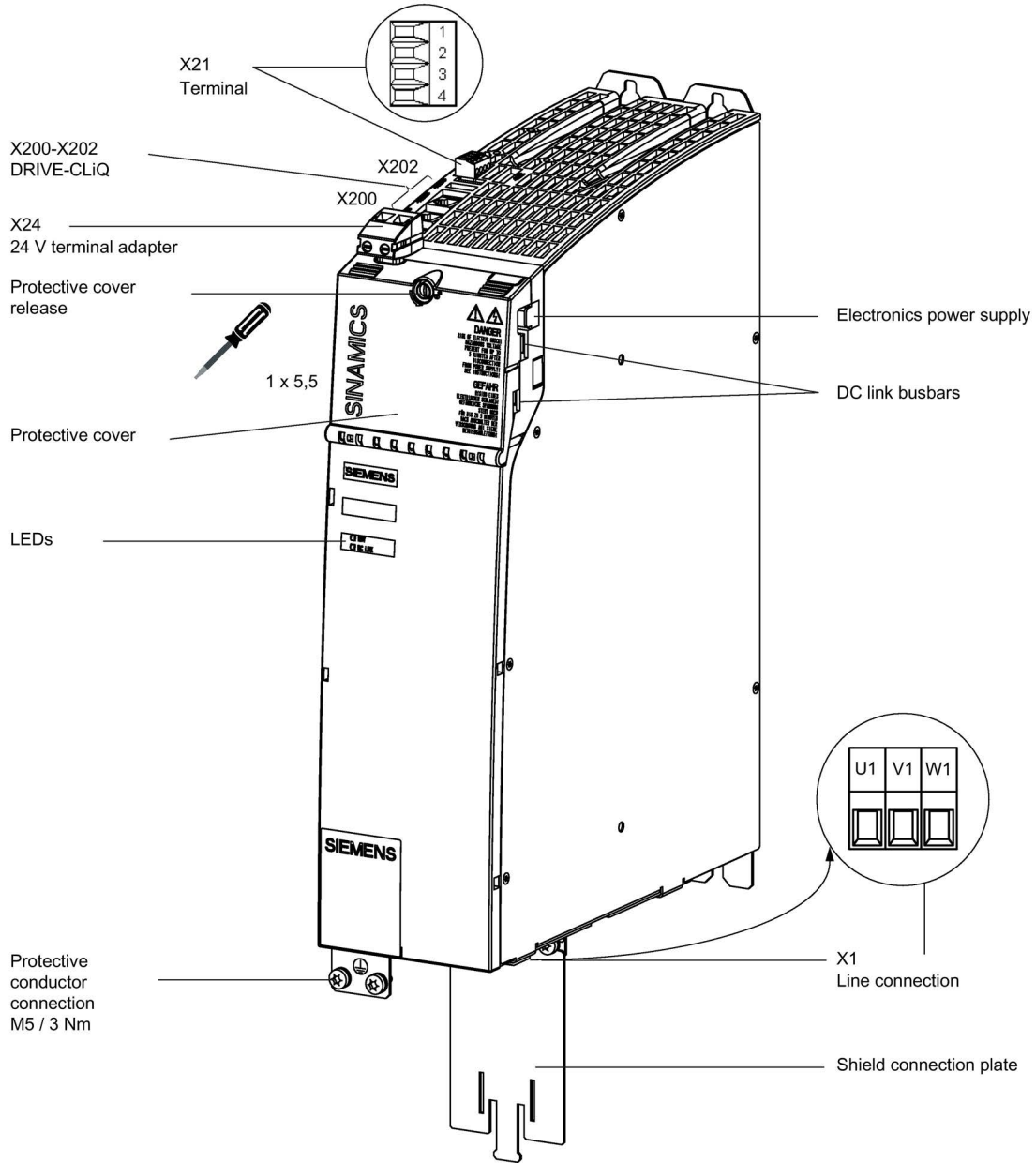

Figure 4-1 Interface overview, Active Line Module with internal air cooling (example: 16 kW)

4.3.2.2 X1 line connection

Table 4- 1 X1: Line connection for Active Line Modules 16 kW

	Terminal	Technical data
	U1 V1 W1	Type: Screw terminal 6 (Page 708)
	Protective conductor connection	Threaded hole M5 / 3 Nm (26.6 lbf in) ¹⁾
¹⁾ For ring cable lugs without insulation (Page 710)		

Table 4- 2 X1: Line supply connection for Active Line Modules 36 kW to 120 kW

	Terminal	Technical data
	U1 V1 W1	Supply voltage: 380 ... 480 V 3 AC, 50/60 Hz 36 kW: Threaded bolt M6 / 6 Nm (53.1 lbf in) ¹⁾ 55 kW, 80 kW and 120 kW: Threaded bolt M8 / 13 Nm (115 lbf in) ¹⁾
	Protective conductor connection	36 kW and 55 kW: Threaded hole M6 / 6 Nm (53.1 lbf in) ¹⁾
		80 kW and 120 kW: Threaded hole M8 / 13 Nm (115 lbf in) ¹⁾
¹⁾ For ring cable lugs without insulation (Page 710)		

4.3 Active Line Modules with internal air cooling

4.3.2.3 X12 fan connection

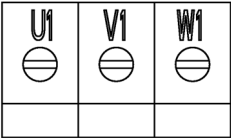
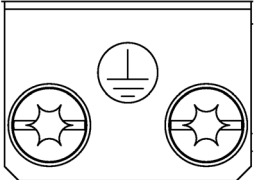
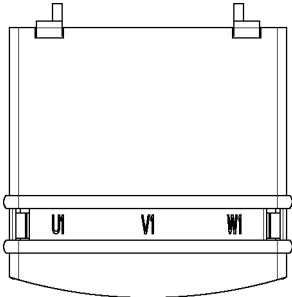
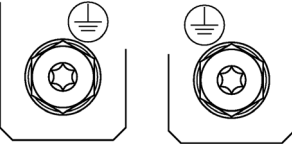
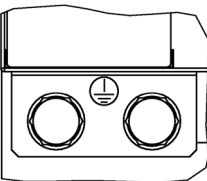
Active Line Modules 80 kW and 120 kW are equipped with an interface for connecting the sub-chassis fan. The interface is located on the underside of the Line Module.

Table 4- 3 X12 fan connection

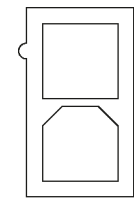
	Terminal	Function	Technical data
	1	Fan connection +	Voltage 48 V DC for the supplied fan
	2	Fan connection -	

4.3.2.4 X21 EP terminals

Table 4- 4 X21 EP terminal / temperature sensor

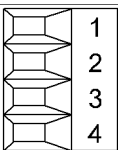
	Terminal	Designation	Technical data
	1	+ Temp	Temperature sensors ¹⁾ : KTY84–1C130 ²⁾ / PT1000 ²⁾ / PTC ²⁾ / bimetallic switch with NC contact If an Active Interface Module is used, the temperature input must be connected to the Active Interface Module sensor (bimetallic switch with NC contact).
	2	- Temp	
	3	EP +24 V (pulse enable)	Voltage: 24 V DC (20.4 ... 28.8 V) Current consumption, typical: 4 mA at 24 V Isolated input
	4	EP M (Enable Pulses)	

Type: Screw terminal 1 (Page 708)

- 1) The temperature sensor type and the temperature output can be selected by parameter (see the SINAMICS S120/S150 List Manual).
- 2) Temperatures are detected but not evaluated in the Active Line Module.

Terminals X21.1 and X21.2

When using an Active Interface Module, its temperature output must be connected at terminals X21.1 and X21.2.

Terminals X21.3 and X21.4

For operation, the 24 V DC voltage must be connected to terminal X21.3 and ground to terminal X21.4.

Pulse cancellation is activated if the power supply is disconnected. As a consequence, regenerative feedback is deactivated and the bypass relay drops out. If the Line Module is not disconnected from the line supply when the EP terminal is de-energized, for example, because a line contactor is not installed, then the DC link remains charged.



⚠ WARNING

Electric shock in the event of voltage flashovers at the temperature sensor

Voltage flashovers in the signal electronics can occur in motors without safe electrical separation of the temperature sensors.

- Use temperature sensors that comply with the specifications relating to protective separation.
- If safe electrical separation cannot be guaranteed (for linear motors or third-party motors, for example), use a Sensor Module External (SME120 or SME125) or Terminal Module TM120.

4.3.2.5 X24 24 V terminal adapter

Table 4- 5 X24: 24 V terminal adapter

	Terminal	Designation	Technical data
	+	24 V power supply	24 V DC supply voltage
	M	Ground	Electronics ground
Type: Screw terminal 5 (Page 708)			

The 24 V terminal adapter is included in the scope of supply.

4.3.2.6 X200-X202 DRIVE-CLiQ interfaces

Table 4- 6 X200-X202: DRIVE-CLiQ interfaces

	PIN	Signal name	Technical data
	1	TXP	Transmit data +
	2	TXN	Transmit data -
	3	RXP	Receive data +
	4	Reserved, do not use	-
	5	Reserved, do not use	-
	6	RXN	Receive data -
	7	Reserved, do not use	-
	8	Reserved, do not use	-
	A	+(24 V)	24 V power supply
	B	M (0 V)	Electronics ground

The blanking covers for the DRIVE-CLiQ interfaces are included in the scope of delivery.

Blanking cover (50 pcs.) Article number: 6SL3066-4CA00-0AA0

4.3.3 Connection example

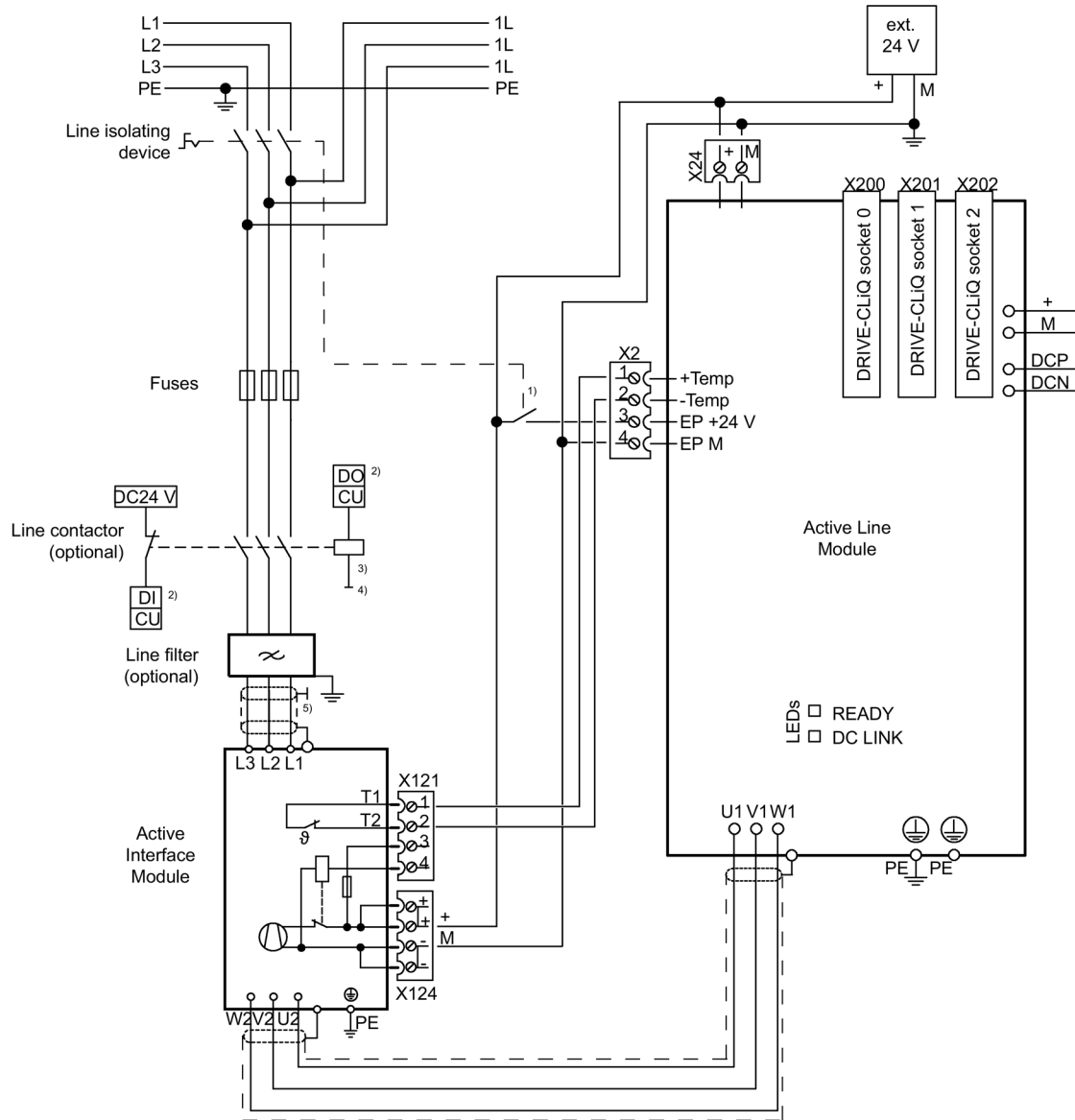

- ¹⁾ Leading opening contact $t > 10$ ms
- ²⁾ DI/DO, controlled by the Control Unit.
- ³⁾ No additional load permitted downstream of the line contactor!
- ⁴⁾ The current carrying capacity of the DO must be observed; an output coupling device may have to be used.
- ⁵⁾ Contact established through the rear mounting panel or shield rails in accordance with the EMC Directive.

Figure 4-2 Example connection of Active Line Module

Note

If you are using a VSM10 Voltage Sensing Module, the leading opening contact can be omitted.

4.3.4 Meaning of LEDs

Table 4- 7 Meaning of the LEDs on the Active Line Module

Status		Description, cause	Remedy
RDY	DC LINK		
off	off	The electronics power supply is missing or outside the permissible tolerance range.	–
Green	-- ¹⁾	The component is ready for operation. Cyclic DRIVE-CLiQ communication is established.	–
	Orange	The component is ready for operation. Cyclic DRIVE-CLiQ communication is established. The DC link voltage is present.	–
	Red	The component is ready for operation. Cyclic DRIVE-CLiQ communication is established. The DC link voltage is outside the permissible tolerance range.	Check the line supply voltage.
Orange	Orange	DRIVE-CLiQ communication is being established.	–
Red	-- ¹⁾	This component has at least one fault.	Resolve and acknowledge the fault.
Green/ red (0.5 Hz)	-- ¹⁾	Firmware is being downloaded.	–
Green/red (2 Hz)	-- ¹⁾	Firmware download has been completed. The system waits for POWER ON.	Carry out a POWER ON.
Green/orange or red/orange	-- ¹⁾	Component recognition via LED is activated ²⁾ . Note: Both options depend on the LED status when component recognition is activated.	–

¹⁾ Irrespective of the status of the LED "DC LINK"

²⁾ For information about activating the parameter "Recognition via LED", see SINAMICS S120/S150 List Manual

4.3.5 Dimension drawings

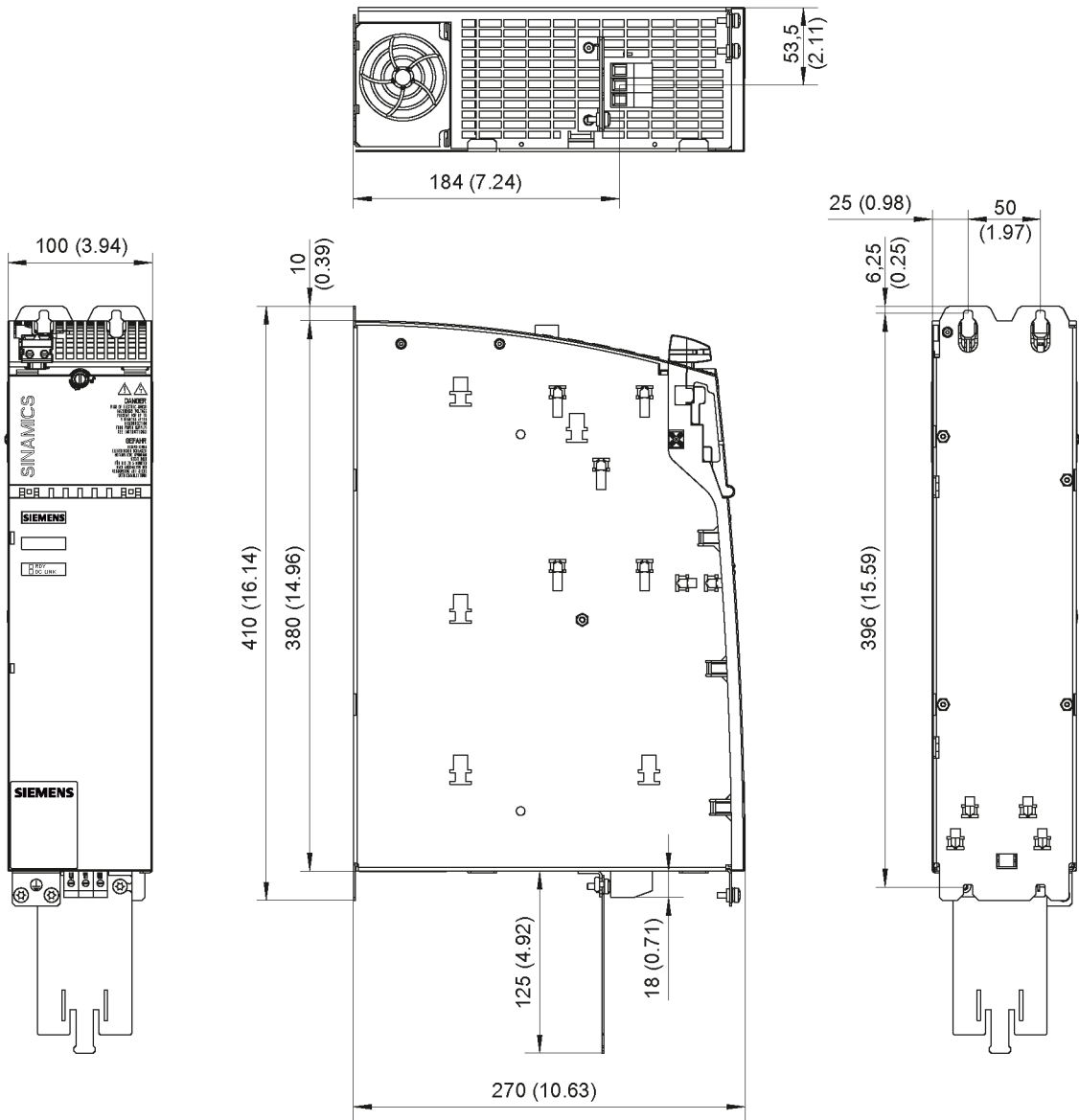

Figure 4-3 Dimension drawing of 16 kW Active Line Module with internal air cooling, all dimensions in mm and (inches)

Note

The shield connecting plate is supplied as standard with a 100 mm Line Module. For more information, see Chapter Shield connecting plates for power supply and motor cables (Page 569).

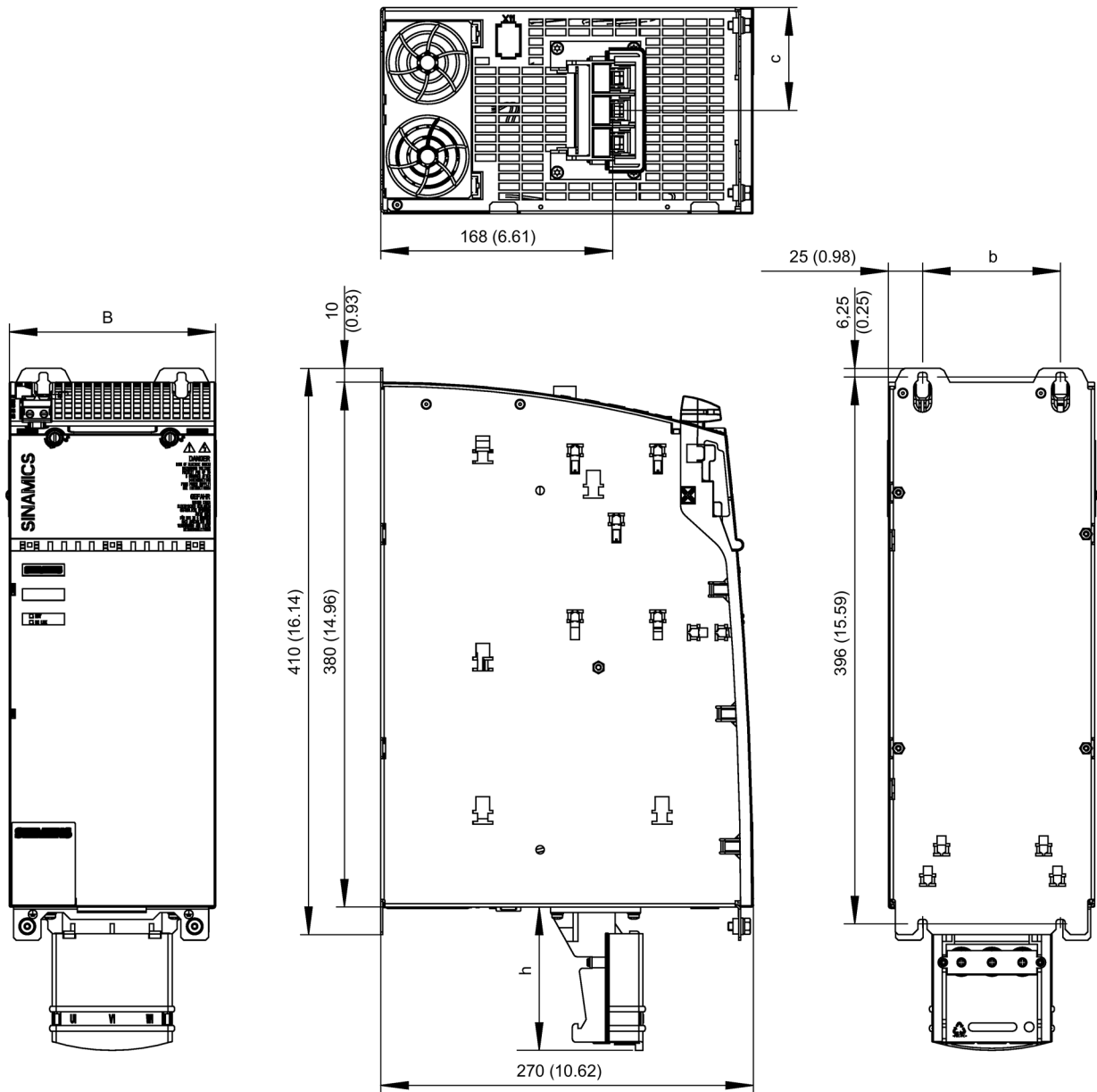

Figure 4-4 Dimension drawing of 36 kW and 55 kW Active Line Modules with internal air cooling (example, 36 kW), all dimensions in mm and (inches)

Table 4- 8 Dimensions of 36 kW and 55 kW Active Line Modules with internal air cooling

Active Line Module	Article No.	W [mm] (inch)	b [mm] (inch)	c [mm] (inch)	h [mm] (inch)
36 kW	6SL3130-7TE23-6AA.	150 (5.91)	100 (3.94)	75 (2.95)	105 (4.13)
55 kW	6SL3130-7TE25-5AA.	200 (7.87)	150 (5.91)	100 (3.94)	105 (4.13)

4.3 Active Line Modules with internal air cooling

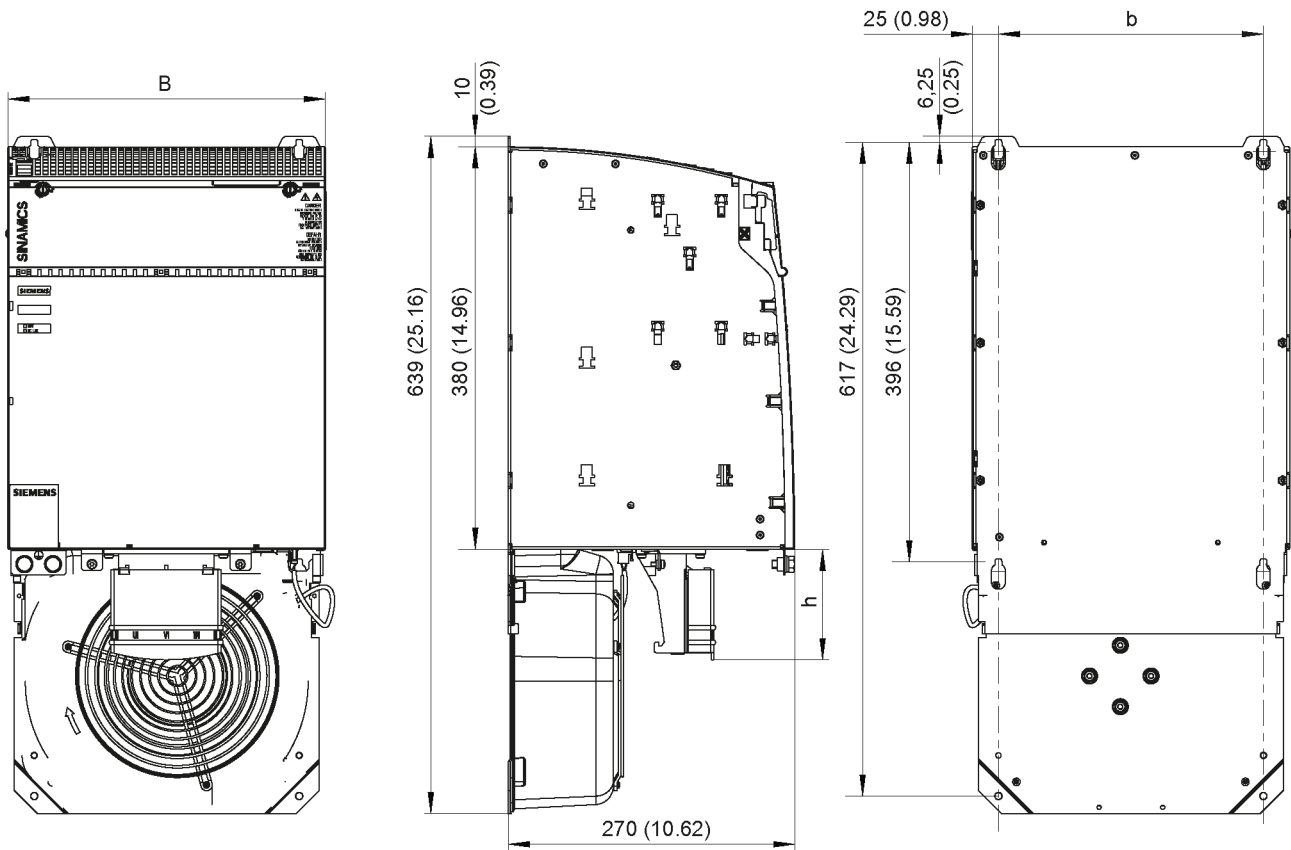

Figure 4-5 Dimension drawing of 80 kW and 120 kW Active Line Modules with internal air cooling, all dimensions in mm and (inches)

Table 4- 9 Dimensions of 80 kW and 120 kW Active Line Modules with internal air cooling

Active Line Module	Article No.	W [mm] (inch)	b [mm] (inch)	h [mm] (inch)
80 kW	6SL3130-7TE28-0AA.	300 (11.81)	250 (9.84)	105 (4.13)
120 kW	6SL3130-7TE31-2AA.	300 (11.81)	250 (9.84)	105 (4.13)

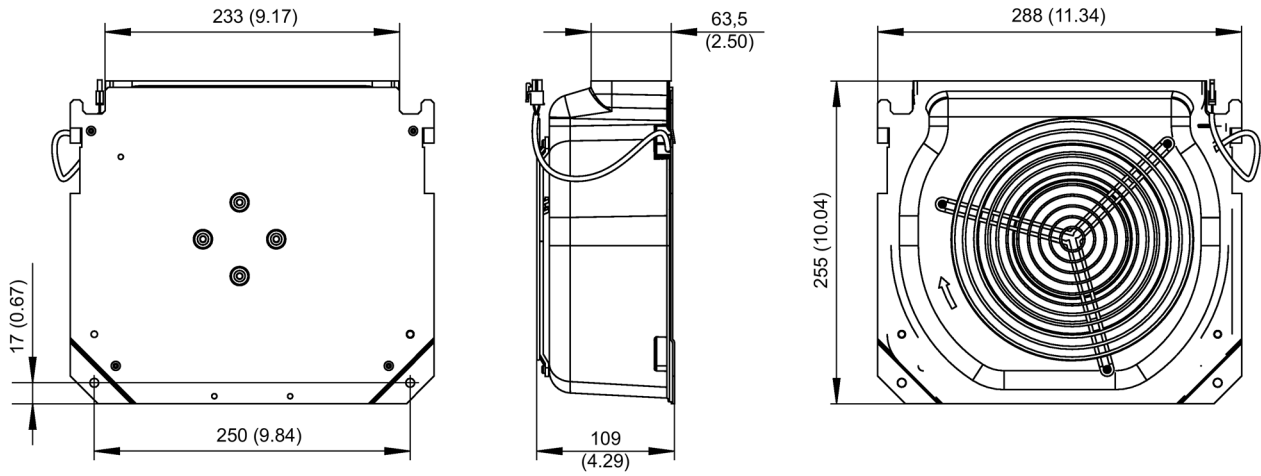

Figure 4-6 Dimension drawing of fan for 80 kW and 120 kW Active Line Modules with internal air cooling, all dimensions in mm and (inches)

Note

The fans for the 80 kW and 120 kW Active Line Modules are included in the scope of delivery.

4.3.6 Installation

Active Line Modules are designed for installation in the control cabinet. They are fixed to the control cabinet panel or a mounting panel using M6 screws.

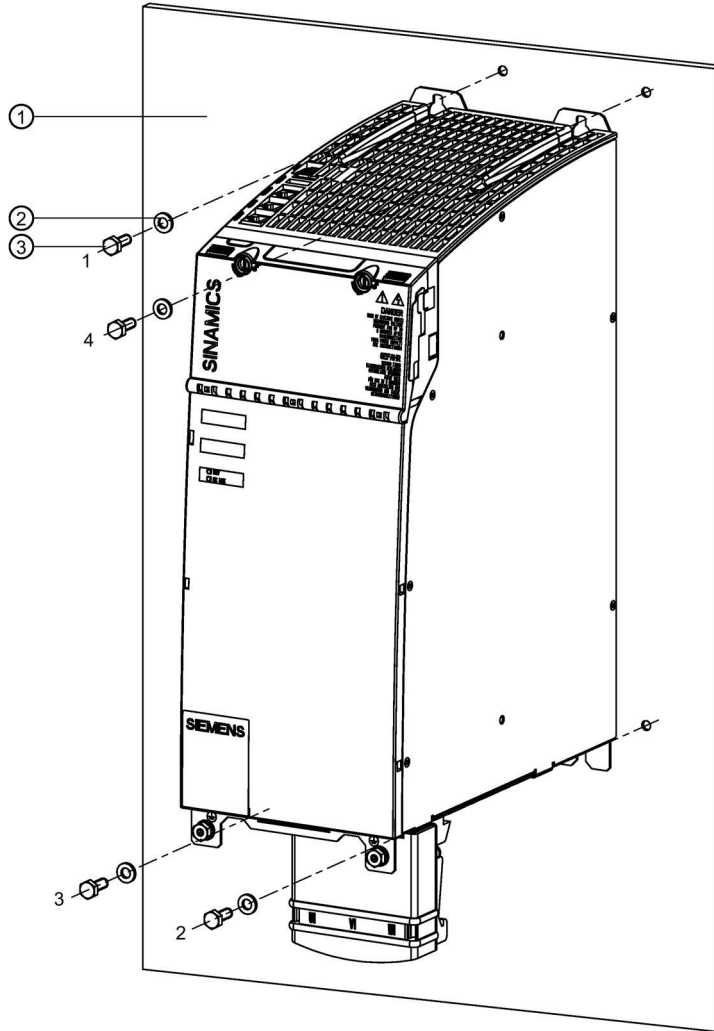

- ① Control cabinet panel/mounting panel
- ② Washer
- ③ M6 screw

Figure 4-7 Mounting an Active Line Module with internal air cooling (example: 36 kW)

Tightening torques:

1. Firstly, tighten the nuts by hand.
Tightening torque: 0.5 Nm (4.4 lbf in)
2. Then tighten the nuts in the specified sequence 1 to 4.
Tightening torque: 6 Nm (53.1 lbf in)

Installing the sub-chassis fan

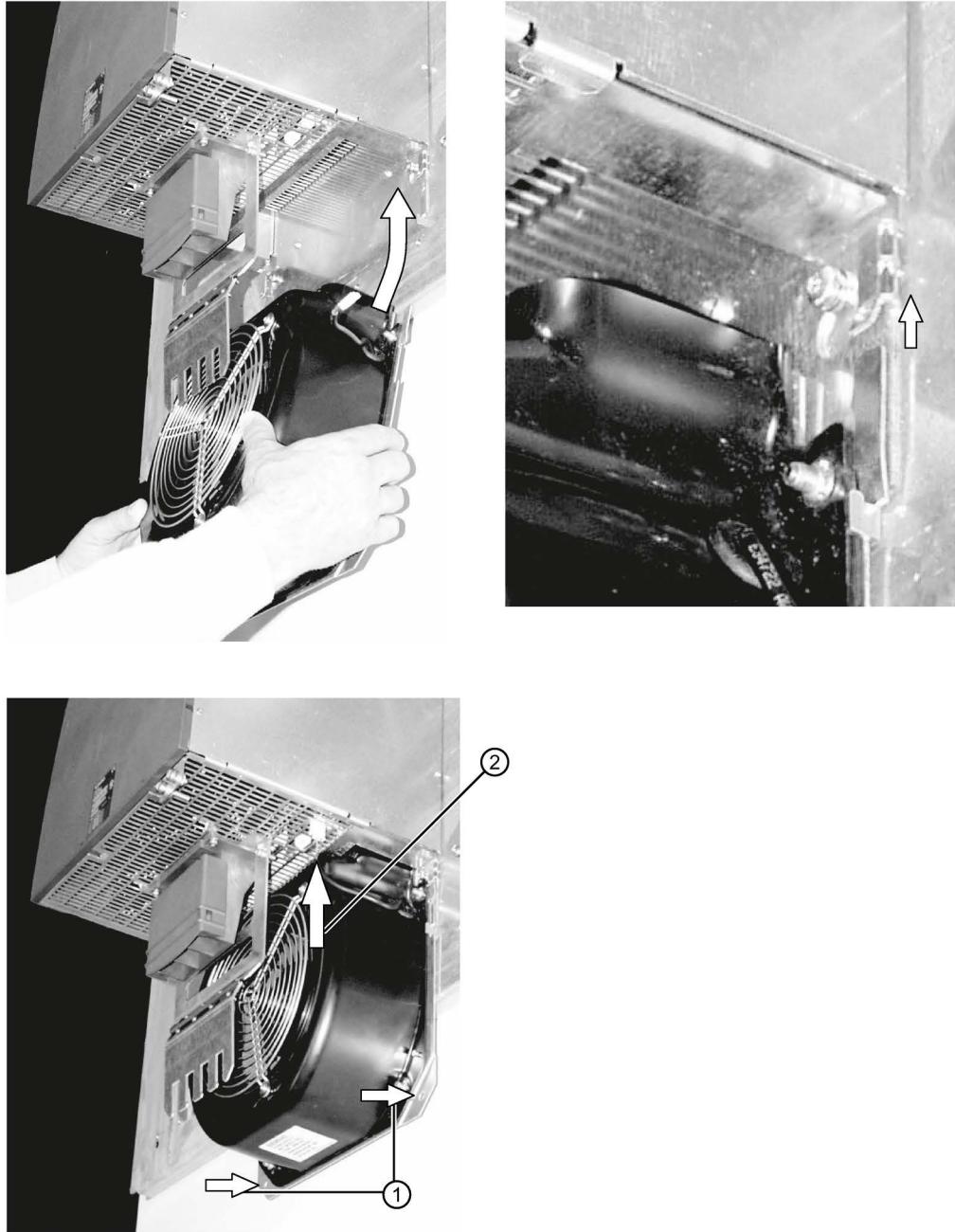

Figure 4-8 Mounting the fan for Active Line Modules 80 kW and 120 kW

- ① Fix the fan with M6 screws; tightening torque: 6 Nm (53.1 lbf in).
- ② Connect the fan power supply.

4.3.7 Technical data

Table 4- 10 Technical data for Active Line Modules with internal air cooling, part 1

Internal air cooling	6SL3130–	7TE21–6AA.	7TE23–6AA.	7TE25–5AA.	7TE25–5AA3 + Active Interface Module
Rated power	kW	16	36	55	55
Infeed¹⁾					
Rated power S1 duty	kW (P_n)	16	36	55	55
Infeed power S6 duty (40 %)	kW (P_{S6})	21	47	71	71
Peak infeed power	kW (P_{max})	35	70	91	110
Regenerative feedback					
Continuous regenerative power	kW	16	36	55	55
Peak regenerative power	kW	35	70	91	110
Supply voltages		3 AC 380 ... 480 \pm 10 % (-15 % < 1 min)			
Line voltage	V_{ACrms}	47 ... 63			
Line frequency	Hz	24 (20.4 ... 28.8)			
Electronics power supply	V_{DC}	510 ... 720			
DC-link voltage	V_{DC}	820 \pm 2 %			
Overvoltage trip	V_{DC}	360 \pm 2 %			
Undervoltage trip ²⁾	V_{DC}				
Input currents					
Rated input current: for AC 400 V	A_{AC}	25	55	84	84
input current: for AC 380 V / AC 480 V	A_{AC}	26 / 21	58 / 46	88 / 70	88 / 70
for AC 400 V; S6 duty (40 %)	A_{AC}	32	71	108	108
for AC 400 V; peak current	A_{AC}	54	107	139	168
DC link currents					
Rated DC link current: at 600 V DC	A_{DC}	27	60	92	92
at 510 V DC / 720 V DC	A_{DC}	27 / 22.2	60 / 50	92 / 76.4	92 / 76.4
DC-link current: for 600 V DC; S6 duty (40 %)	A_{DC}	35	79	121	121
for 600 V DC; peak current	A_{DC}	59	117	152	176
Current carrying capacity					
DC link busbars	A_{DC}	100	200	200	200
Reinforced DC link busbars	A_{DC}	150	--	--	--
24 V DC busbars	A_{DC}	20	20	20	20
Electronics current consumption at 24 V DC	A_{DC}	0.95	1.5	1.9	1.9
Total power loss (including electronics losses, see Power loss tables (Page 734))	W	282.8	666	945.6	945.6
DC link capacitance					
Active Line Module	μF	705	1410	1880	1880
Drive line-up, max.	μF	20000	20000	20000	20000
Power factor	$\cos \varphi$	1	1	1	1

4.3 Active Line Modules with internal air cooling

Internal air cooling	6SL3130–	7TE21–6AA.	7TE23–6AA.	7TE25–5AA.	7TE25–5AA3 + Active Interface Module
Rated power	kW	16	36	55	55
Circuit breaker (IEC 60947 and UL)		See Chapter Overcurrent protection using fuses and circuit breakers (Page 47)			
Max. total cable length³⁾		See Chapter Combination options, Line Modules with line reactors and line filters (Page 120)			
Sound pressure level	dB(A)	< 60	< 65	< 60	< 60
Cooling method (internal air cooling)		Internal fan			
Cooling air requirement	m³/h	56	112	160	160
Max. permissible heat sink temperature	°C	85	90	83	83
Ventilation clearances above/below	mm	≥ 80			
Rated voltage for rated data 3 AC 380 V					
Weight	kg	7	10.7	16	17

- 1) The specified power ratings apply to the line voltage range from 380 V to 480 V.
2) Default for 400 V line systems; undervoltage trip threshold is adjusted to the parameterized rated voltage
3) Maximum total cable length = Σ motor cables, line feeder cable from line filter to the Line Module

Table 4- 11 Technical data for Active Line Modules with internal air cooling, part 2

Internal air cooling	6SL3130–	7TE28–0AA.	7TE31–2AA.
Rated power	kW	80	120
Infeed¹⁾ Rated power S1 duty Infeed power S6 duty (40 %) Peak infeed power	kW (P_n) kW (P_{S6}) kW (P_{max})	80 106 131	120 145 175
Regenerative feedback Continuous regenerative power Peak regenerative power	kW kW	80 131	120 175
Supply voltages Line voltage Line frequency Electronics power supply	V_{ACrms} Hz V_{DC}	3 AC 380 ... 480 ±10 % (-15 % < 1 min) 47 ... 63 24 (20.4 ... 28.8)	
DC-link voltage Overvoltage trip Undervoltage trip ²⁾	V_{DC} V_{DC} V_{DC}	510 ... 720 820 ± 2 % 360 ± 2 %	
Input currents Rated input current: for AC 400 V input current: for AC 380 V / AC 480 V for AC 400 V; S6 duty (40 %) for AC 400 V; peak current	A_{AC} A_{AC} A_{AC} A_{AC}	122 128 / 102 161 200	182 192 / 152 220 267

4.3 Active Line Modules with internal air cooling

Internal air cooling	6SL3130-	7TE28-0AA.	7TE31-2AA.
Rated power	kW	80	120
DC link currents Rated DC link current: at 600 V DC at 510 V DC / 720 V DC DC-link current: for 600 V DC; S6 duty (40 %) for 600 V DC; peak current	A _{DC} A _{DC} A _{DC} A _{DC}	134 134 / 111 176 218	200 200 / 167 244 292
Current carrying capacity DC link busbars 24 V busbars	A _{DC} A _{DC}	200 20	200 20
Electronics current consumption at 24 V DC	A _{DC}	1.4	1.8
Total power loss (including electronics losses, see Power loss tables (Page 734))	W	1383.6	2243.2
DC link capacitance Active Line Module Drive line-up, max.	μF μF	2820 20000	3995 20000
Power factor	cos φ	1	1
Circuit breaker (IEC 60947 and UL)		See Chapter Overcurrent protection using fuses and circuit breakers (Page 47)	
Max. total cable length³⁾		See Chapter Combination options, Line Modules with line reactors and line filters (Page 120)	
Sound pressure level	dB(A)	< 73	< 73
Cooling method (internal air cooling)		Mounted fan	
Cooling air requirement	m ³ /h	520	520
Max. permissible heat sink temperature	°C	70	75
Ventilation clearances above/below in front of the mounted fan	mm mm		≥ 80 ≥ 50
Rated voltage for rated data 3 AC 380 V			
Weight	kg	23	23

- 1) The specified power ratings apply to the line voltage range from 380 V to 480 V.
- 2) Default for 400 V line systems; undervoltage trip threshold is adjusted to the parameterized rated voltage
- 3) Maximum total cable length = Σ motor cables, line feeder cable from line filter to the Line Module

4.3.7.1 Characteristics

Rated duty cycles for Active Line Modules

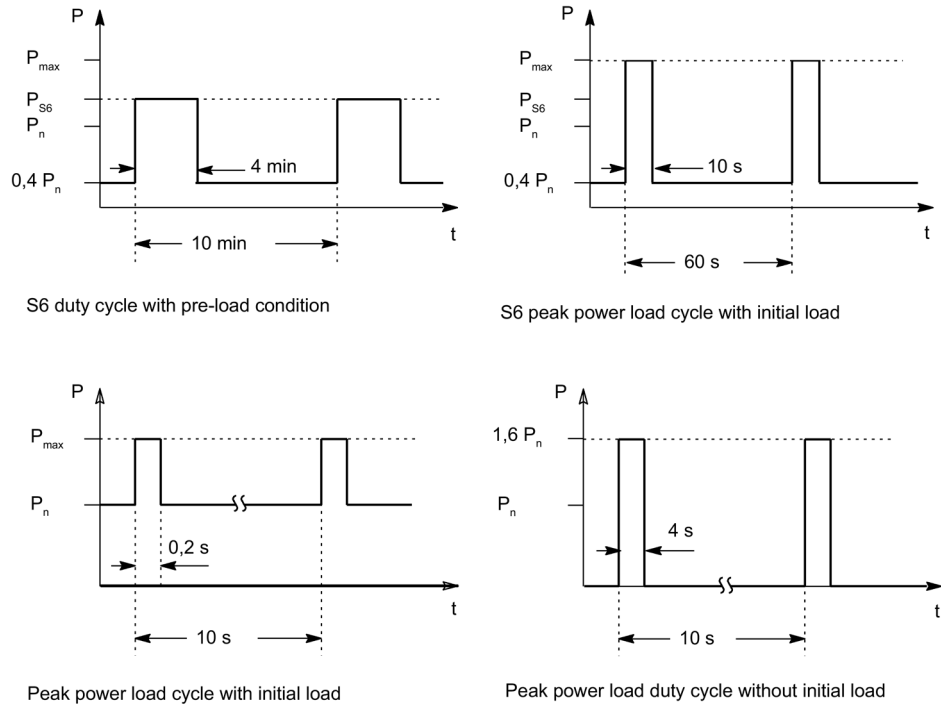

Figure 4-9 Rated duty cycles for Active Line Modules (**exception:** not applicable for 55 kW Active Line Module with Active Interface Module)

Rated duty cycles for Active Line Modules with Active Interface Modules

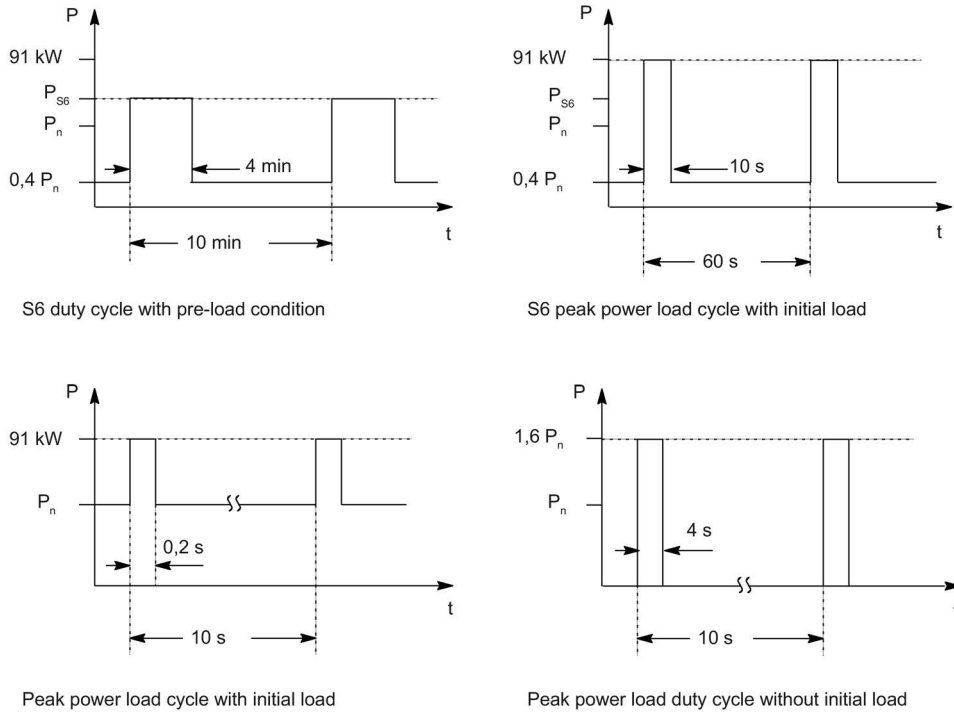

Figure 4-10 Load cycles for 55 kW Active Line Modules with Active Interface Module

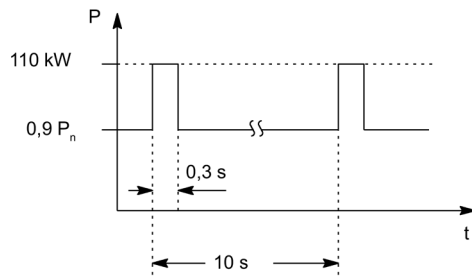

Figure 4-11 Peak load cycle with initial load for 55 kW Active Line Modules with Active Interface Module

4.4 Active Line Modules with external air cooling

4.4.1 Description

Active Line Modules with external air cooling connect Motor Modules with the line supply. Active Line Modules provide a constant DC link voltage for the Motor Modules

This ensures that they are not influenced by line voltage fluctuations.

When motors brake, Active Line Modules feed energy back into the line supply. The regenerative feedback capability of the modules can be deactivated by parameterization.

The DC link starts precharging as soon as the line voltage is applied and is independent of its phase sequence direction. Load can be applied to the DC link after the module has been enabled.

A line contactor can be installed on the line side if the system has to be electrically isolated from the line supply.

Active Line Modules can be directly connected to TN, IT and TT systems. The Line Modules have an integrated overvoltage protection function.

External air cooling uses the "through-hole" method. The power unit and its heat sink can be inserted in a rectangular knockout at the rear of the control cabinet and mounted with a seal. Heat sink and the fan (included in the scope of supply) protrude beyond the rear of the control cabinet and the heat is dissipated outside the control cabinet or in a separate air duct.

4.4.2 Interface description

4.4.2.1 Overview

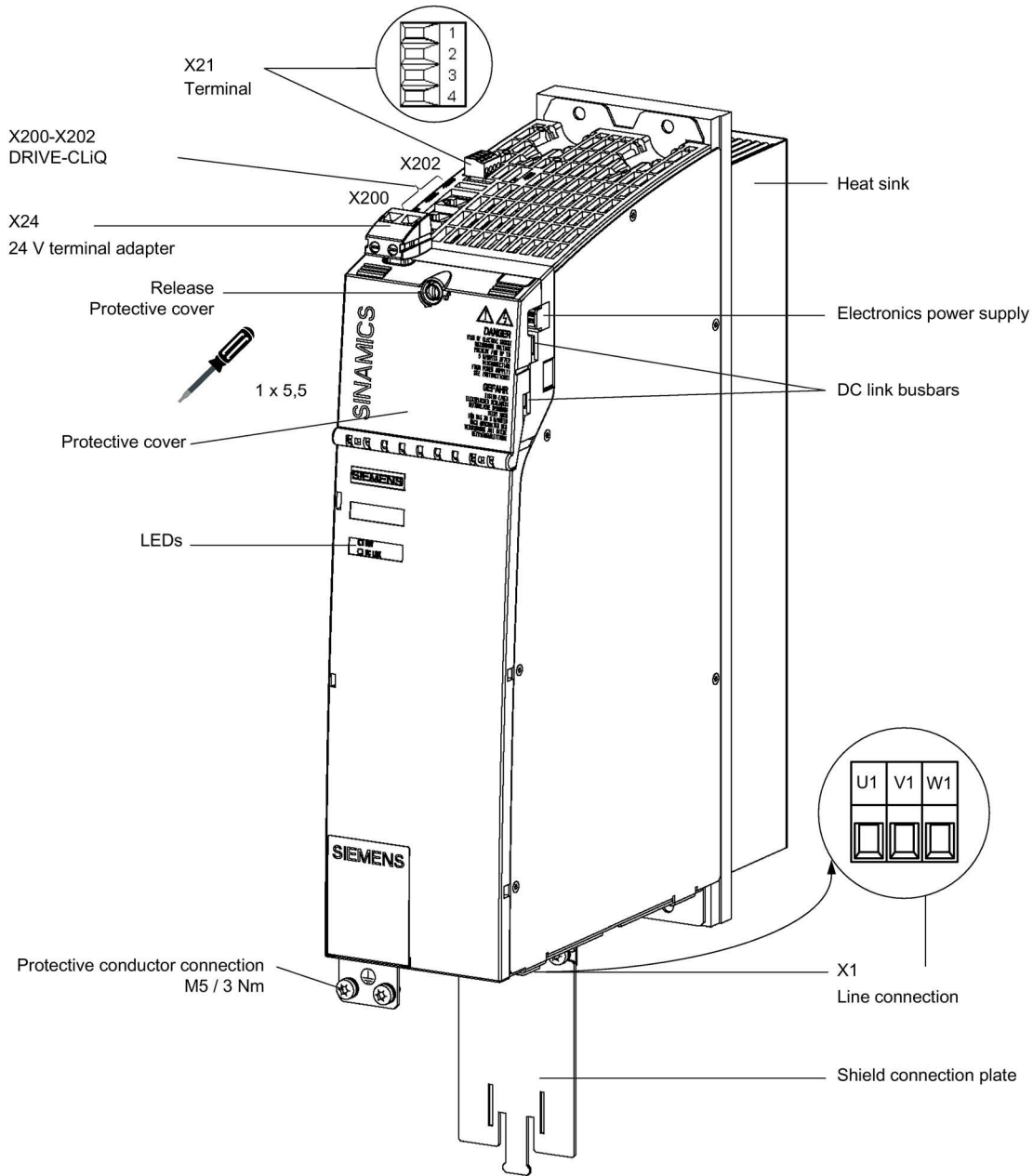

Figure 4-12 Interface overview, Active Line Module with external air cooling (example: 16 kW)

4.4.2.2 X1 line connection

Table 4- 12 X1: Line connection for Active Line Modules 16 kW

	Terminal	Technical data
	U1	Type: Screw terminal 6 (Page 708)
	V1	
	W1	
	Protective conductor connection	Threaded hole M5 / 3 Nm (26.6 lbf in) ¹⁾
¹⁾ For ring cable lugs without insulation (Page 710)		

Table 4- 13 X1: Line supply connection for Active Line Modules 36 kW to 120 kW

	Terminal	Technical data
	U1	Supply voltage: 380 ... 480 V 3 AC, 50/60 Hz 36 kW: Threaded bolt M6 / 6 Nm (53.1 lbf in) ¹⁾ 55 kW, 80 kW and 120 kW: Threaded bolt M8 / 13 Nm (115 lbf in) ¹⁾
	V1	
	W1	
	Protective conductor connection	36 kW and 55 kW: Threaded hole M6 / 6 Nm (53.1 lbf in) ¹⁾
		80 kW and 120 kW: Threaded hole M8 / 13 Nm (115 lbf in) ¹⁾
¹⁾ For ring cable lugs without insulation (Page 710)		

4.4.2.3 X12 fan connection

Active Line Modules 80 kW and 120 kW are equipped with an interface for connecting the sub-chassis fan. The interface is located on the underside of the Line Module.

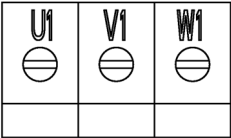
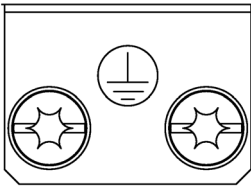
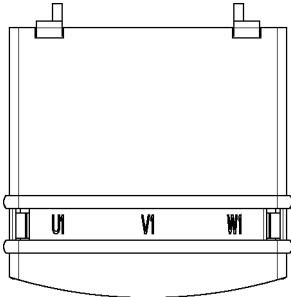
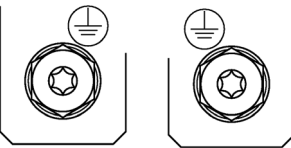
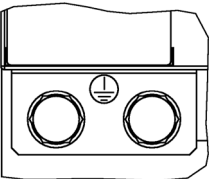
Table 4- 14 X12 fan connection

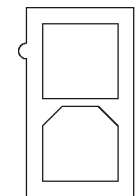
	Terminal	Function	Technical data
	1	Fan connection +	Voltage 48 V DC for the supplied fan
	2	Fan connection -	

4.4.2.4 X21 EP terminals

Table 4- 15 X21 EP terminal / temperature sensor

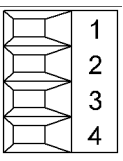
	Terminal	Designation	Technical data
	1	+ Temp	Temperature sensors ¹⁾ : KTY84–1C130 ²⁾ / PT1000 ²⁾ / PTC ²⁾ / bimetallic switch with NC contact If an Active Interface Module is used, the temperature input must be connected to the Active Interface Module sensor (bimetallic switch with NC contact).
	2	- Temp	
	3	EP +24 V (pulse enable)	Voltage: 24 V DC (20.4 ... 28.8 V) Current consumption, typical: 4 mA at 24 V Isolated input
	4	EP M (Enable Pulses)	

Type: Screw terminal 1 (Page 708)

- 1) The temperature sensor type and the temperature output can be selected by parameter (see the SINAMICS S120/S150 List Manual).
- 2) Temperatures are detected but not evaluated in the Active Line Module.

Terminals X21.1 and X21.2

When using an Active Interface Module, its temperature output must be connected at terminals X21.1 and X21.2.

Terminals X21.3 and X21.4

For operation, the 24 V DC voltage must be connected to terminal X21.3 and ground to terminal X21.4.

Pulse cancellation is activated if the power supply is disconnected. As a consequence, regenerative feedback is deactivated and the bypass relay drops out. If the Line Module is not disconnected from the line supply when the EP terminal is de-energized, for example, because a line contactor is not installed, then the DC link remains charged.



! WARNING

Electric shock in the event of voltage flashovers at the temperature sensor

Voltage flashovers in the signal electronics can occur in motors without safe electrical separation of the temperature sensors.

- Use temperature sensors that comply with the specifications relating to protective separation.
- If safe electrical separation cannot be guaranteed (for linear motors or third-party motors, for example), use a Sensor Module External (SME120 or SME125) or Terminal Module TM120.

4.4.2.5 X24 24 V terminal adapter

Table 4- 16 X24: 24 V terminal adapter

	Terminal	Designation	Technical data
	+	24 V power supply	24 V DC supply voltage
	M	Ground	Electronics ground
Type: Screw terminal 5 (Page 708)			

The 24 V terminal adapter is included in the scope of supply.

4.4.2.6 X200-X202 DRIVE-CLiQ interfaces

Table 4- 17 X200-X202: DRIVE-CLiQ interfaces

	PIN	Signal name	Technical data
	1	TXP	Transmit data +
	2	TXN	Transmit data -
	3	RXP	Receive data +
	4	Reserved, do not use	-
	5	Reserved, do not use	-
	6	RXN	Receive data -
	7	Reserved, do not use	-
	8	Reserved, do not use	-
	A	+(24 V)	24 V power supply
	B	M (0 V)	Electronics ground

The blanking covers for the DRIVE-CLiQ interfaces are included in the scope of delivery.

Blanking cover (50 pcs.) Article number: 6SL3066-4CA00-0AA0

4.4.3 Connection example

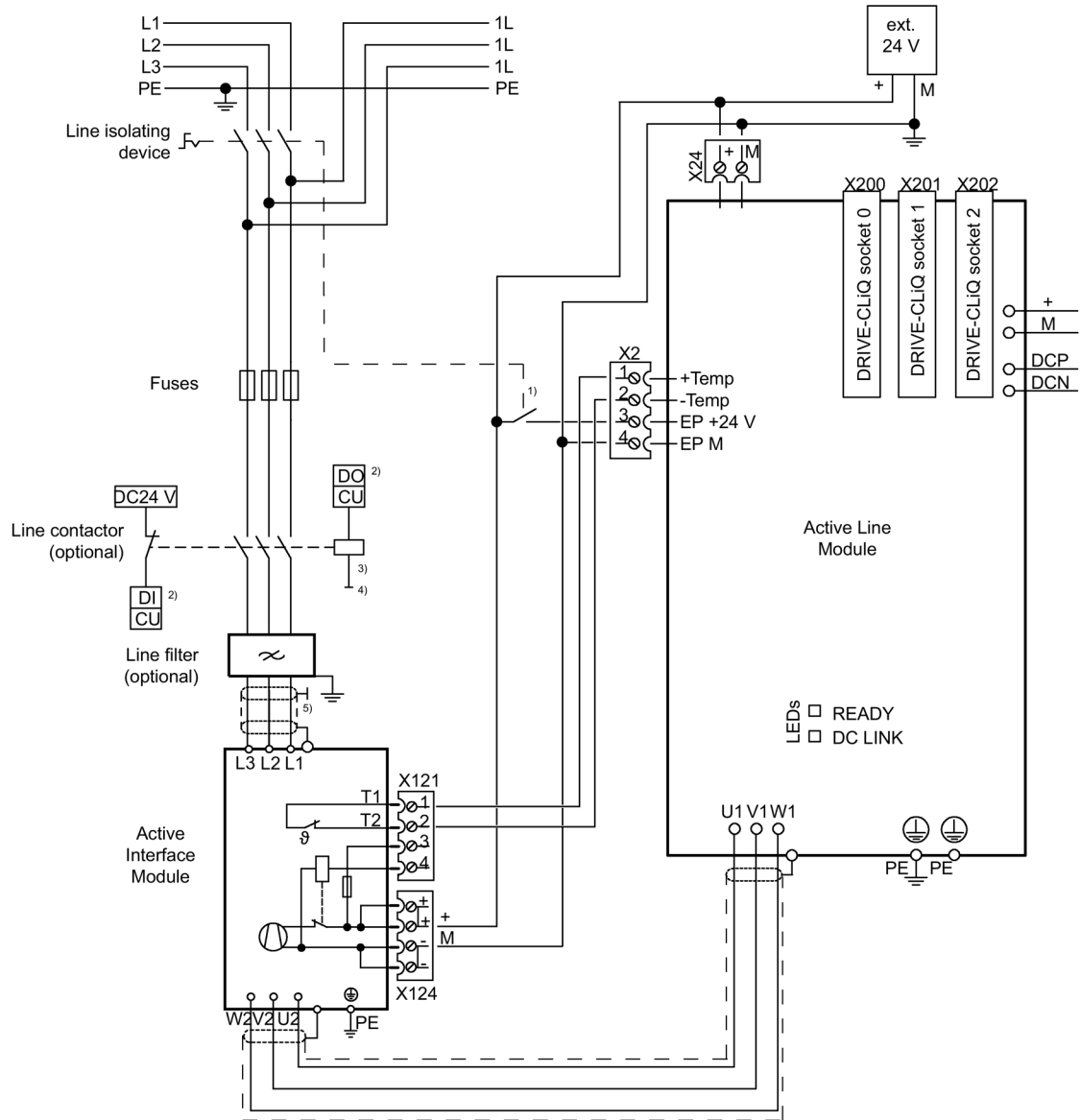

- 1) Leading opening contact $t > 10$ ms
- 2) DI/DO, controlled by the Control Unit.
- 3) No additional load permitted downstream of the line contactor!
- 4) The current carrying capacity of the DO must be observed; an output coupling device may have to be used.
- 5) Contact established through the rear mounting panel or shield rails in accordance with the EMC Directive.

Figure 4-13 Example connection of Active Line Module

Note

If you are using a VSM10 Voltage Sensing Module, the leading opening contact can be omitted.

4.4.4 Meaning of LEDs

Table 4- 18 Meaning of the LEDs on the Active Line Module

Status		Description, cause	Remedy
RDY	DC LINK		
off	off	The electronics power supply is missing or outside the permissible tolerance range.	–
Green	-- ¹⁾	The component is ready for operation. Cyclic DRIVE-CLiQ communication is established.	–
	Orange	The component is ready for operation. Cyclic DRIVE-CLiQ communication is established. The DC link voltage is present.	–
	Red	The component is ready for operation. Cyclic DRIVE-CLiQ communication is established. The DC link voltage is outside the permissible tolerance range.	Check the line supply voltage.
Orange	Orange	DRIVE-CLiQ communication is being established.	–
Red	-- ¹⁾	This component has at least one fault.	Resolve and acknowledge the fault.
Green/ red (0.5 Hz)	-- ¹⁾	Firmware is being downloaded.	–
Green/red (2 Hz)	-- ¹⁾	Firmware download has been completed. The system waits for POWER ON.	Carry out a POWER ON.
Green/orange or red/orange	-- ¹⁾	Component recognition via LED is activated ²⁾ . Note: Both options depend on the LED status when component recognition is activated.	–

¹⁾ Irrespective of the status of the LED "DC LINK"

²⁾ For information about activating the parameter "Recognition via LED", see SINAMICS S120/S150 List Manual

4.4.5 Dimension drawings

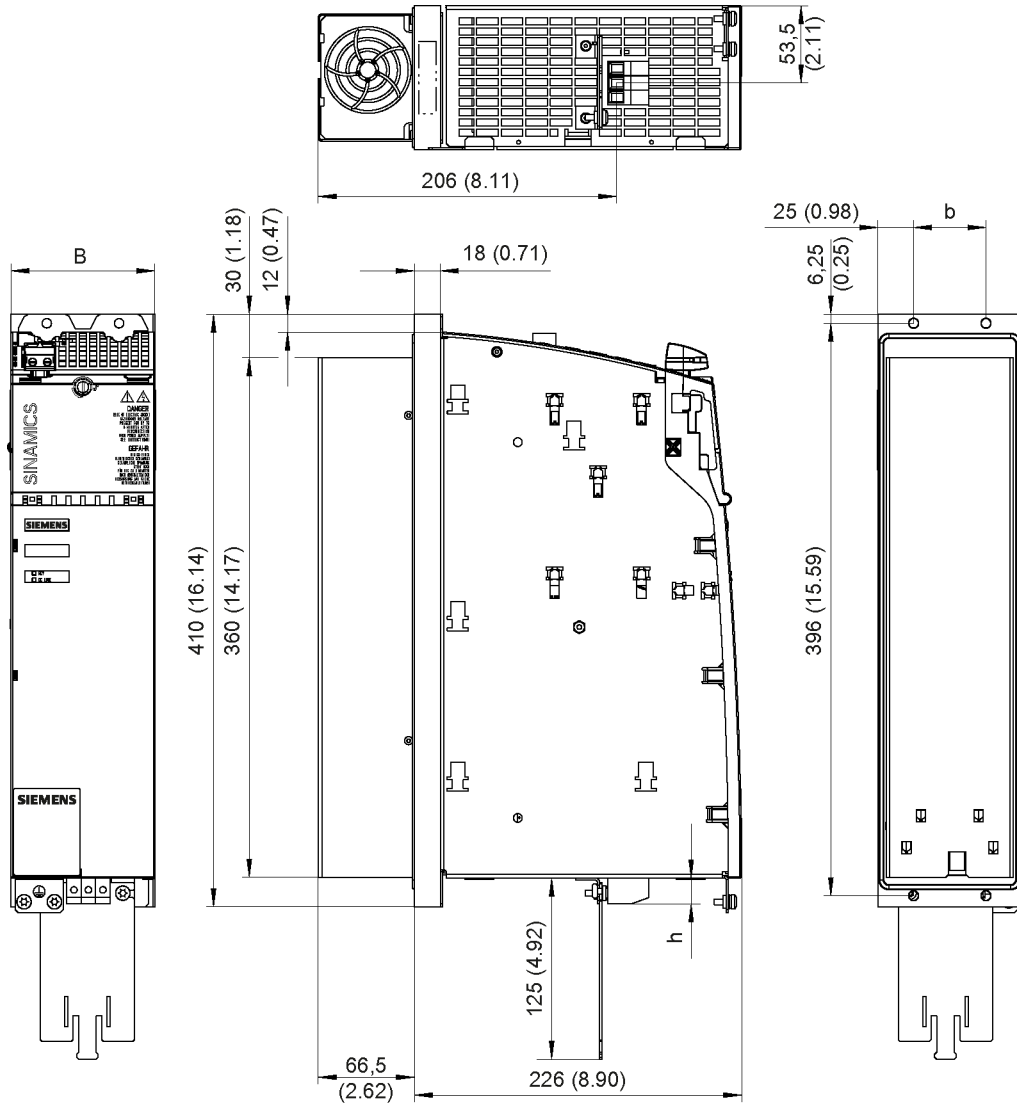

Figure 4-14 Dimension drawing of 16 kW Active Line Module with external air cooling, all dimensions in mm and (inches)

Table 4- 19 Dimensions of 16 kW Active Line Module with external air cooling

Active Line Module	Article No.	B [mm] (inch)	b [mm] (inch)	h [mm] (inch)
16 kW	6SL3131-7TE21-6AA.	100 (3.94)	50 (1.97)	18 (0.71)

Note

The shield connecting plate is supplied as standard with a 100 mm Line Module. For more information, see Chapter Shield connecting plates for power supply and motor cables (Page 569).

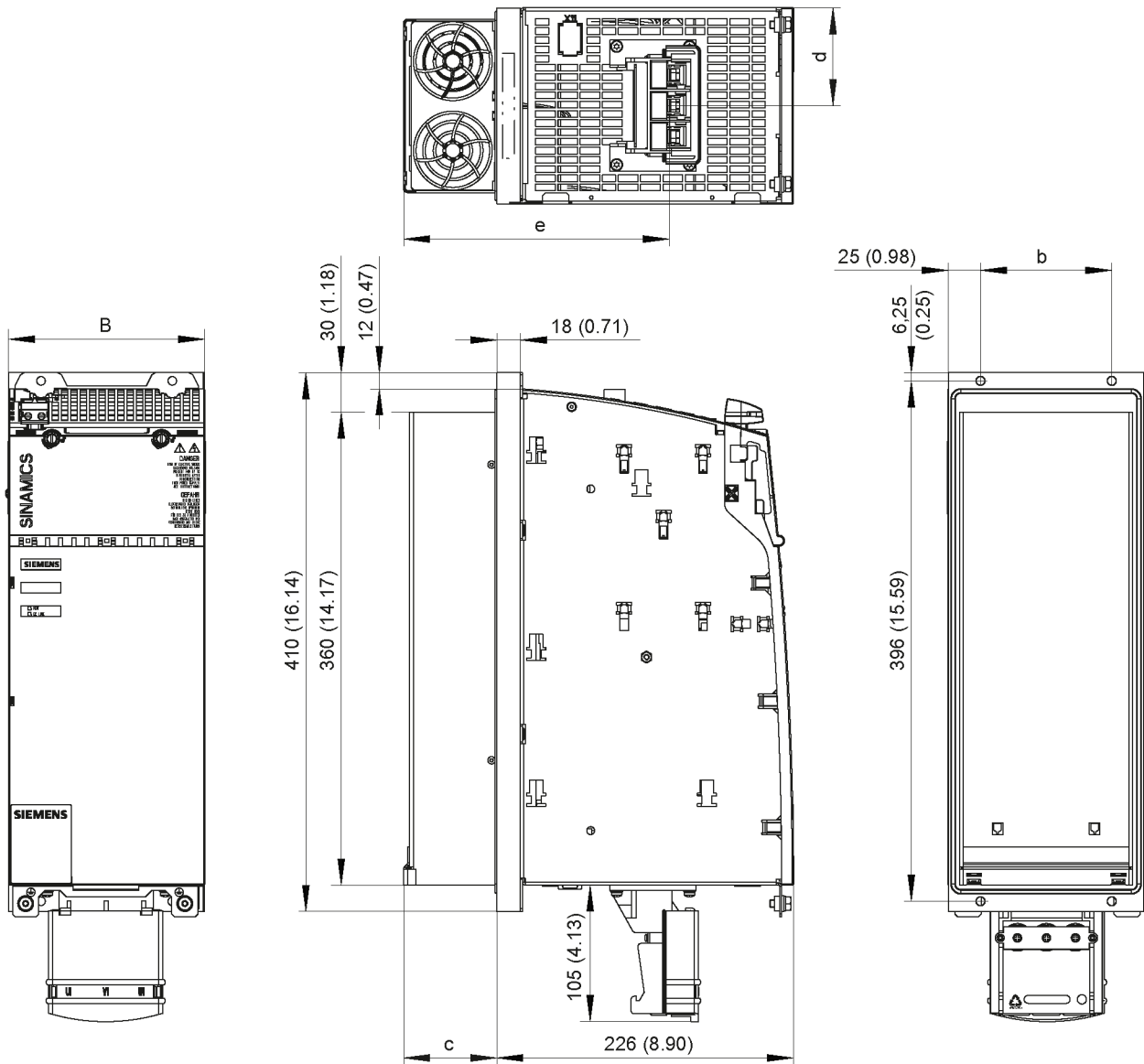

Figure 4-15 Dimension drawing of 36 kW, 55 kW, 80 kW, and 120 kW Active Line Modules with external air cooling (example 36 kW), all dimensions in mm and (inches)

Table 4- 20 Dimensions of 36 kW, 55 kW, 80 kW, and 120 kW Active Line Modules with external air cooling

Active Line Mod-ule	Article No.	B [mm] (inch)	b [mm] (inch)	c [mm] (inch)	d [mm] (inch)	e [mm] (inch)
36 kW	6SL3131-7TE23-6AA.	150 (5.91)	100 (3.94)	71 (2.80)	75 (2.95)	203 (7.99)
55 kW	6SL3131-7TE25-5AA.	200 (7.87)	150 (5.91)	92 (3.62)	100 (3.94)	224 (8.82)
80 kW	6SL3131-7TE28-0AA.	300 (11.81)	250 (9.84)	82 (3.23)	150 (5.91)	214 (8.43)
120 kW	6SL3131-7TE31-2AA.	300 (11.81)	250 (9.84)	82 (3.23)	150 (5.91)	214 (8.43)

4.4 Active Line Modules with external air cooling

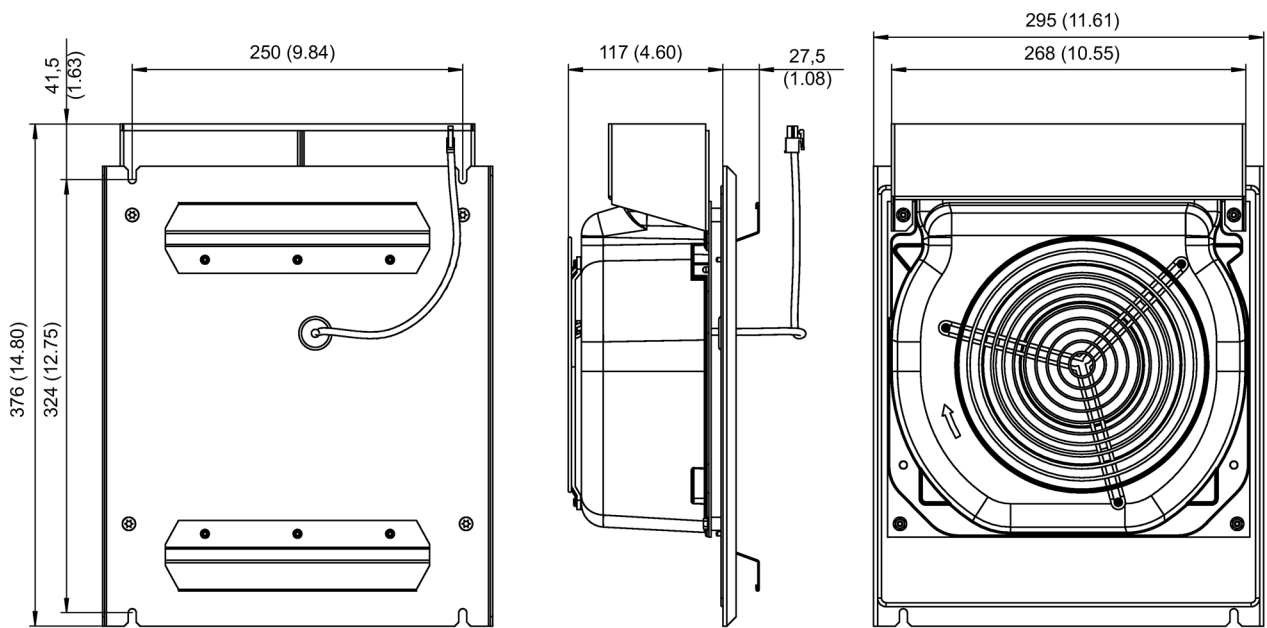
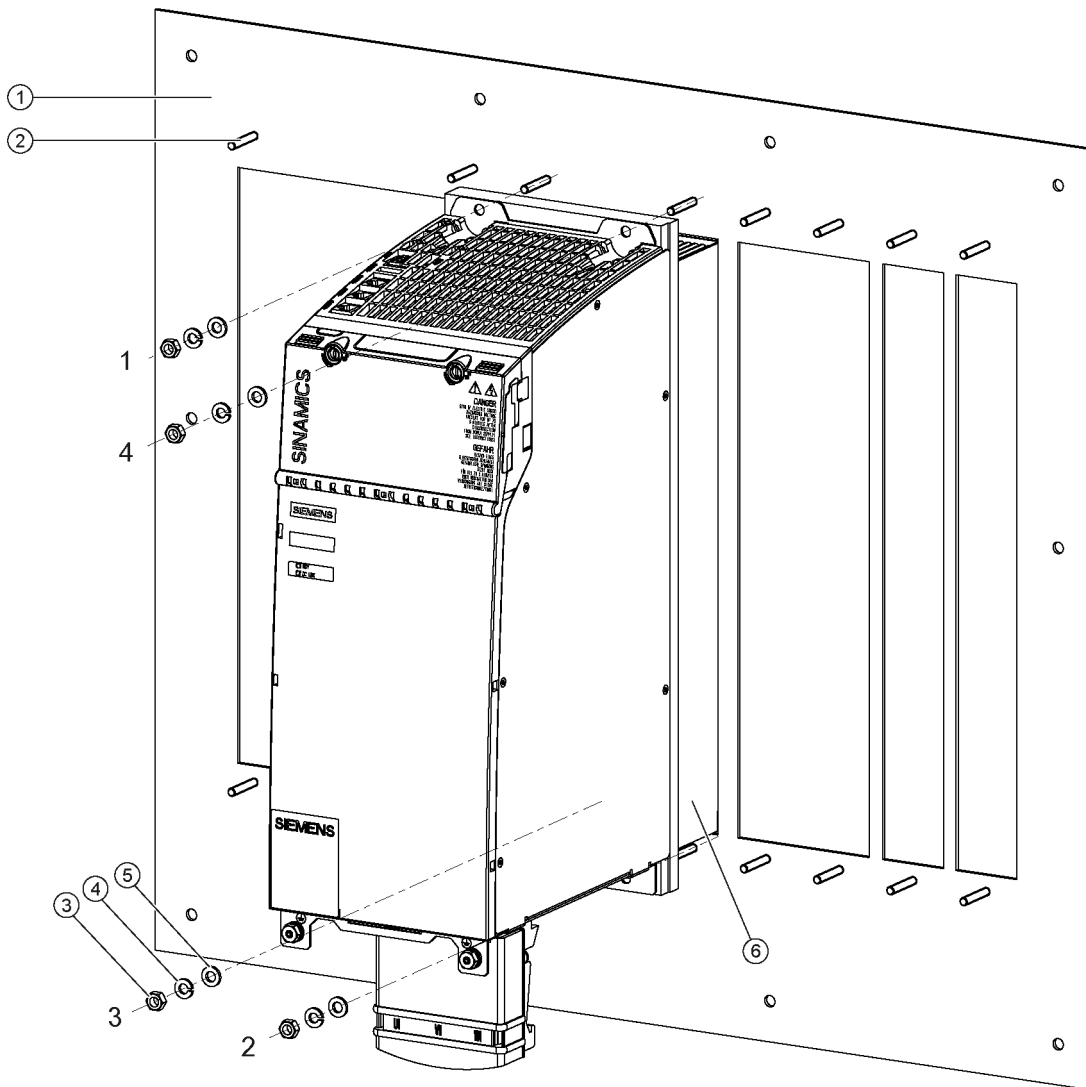

Figure 4-16 Dimension drawing of fan for 80 kW and 120 kW Active Line Modules with external air cooling, all dimensions in mm and (inches)

4.4.6 Installation



- ① Mounting plate with openings for mounting
- ② Threaded bolts M6
- ③ M6 nut
- ④ Spring washer
- ⑤ Washer
- ⑥ Fan assembly

Figure 4-17 Mounting an Active Line Module with external air cooling (example: 36 kW)

Tightening torques:

1. Firstly, tighten the nuts by hand.
Tightening torque: 0.5 Nm (4.4 lbf in)
2. Then tighten the nuts in the specified sequence 1 to 4.
Tightening torque: 6 Nm (53.1 lbf in)

Help with the mechanical control cabinet design is available from:

Siemens AG
Digital Factory, DF MC MF - WKC AS
TCCCC (Technical Competence Center Cabinets Chemnitz)
Postfach 1124
09070 Chemnitz
e-mail: cc.cabinetcooling.aud@siemens.com

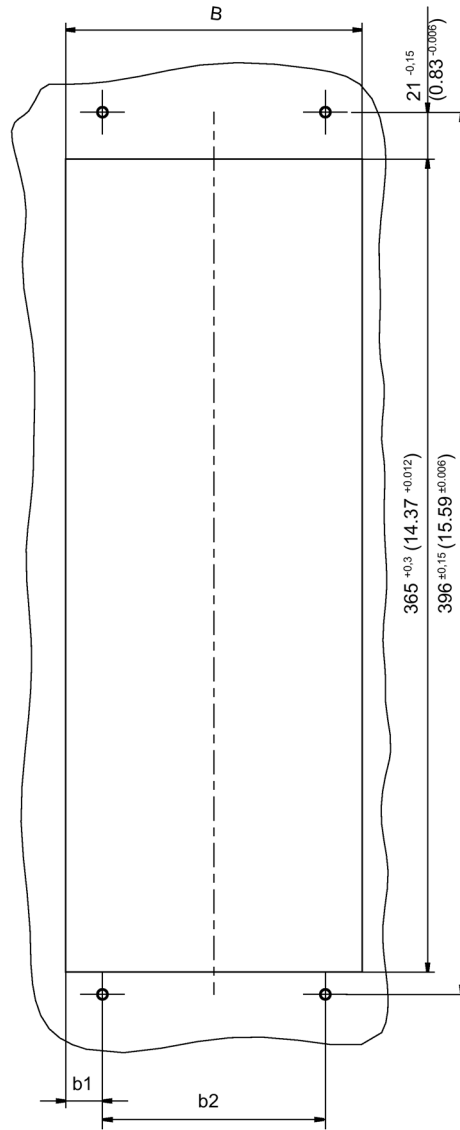
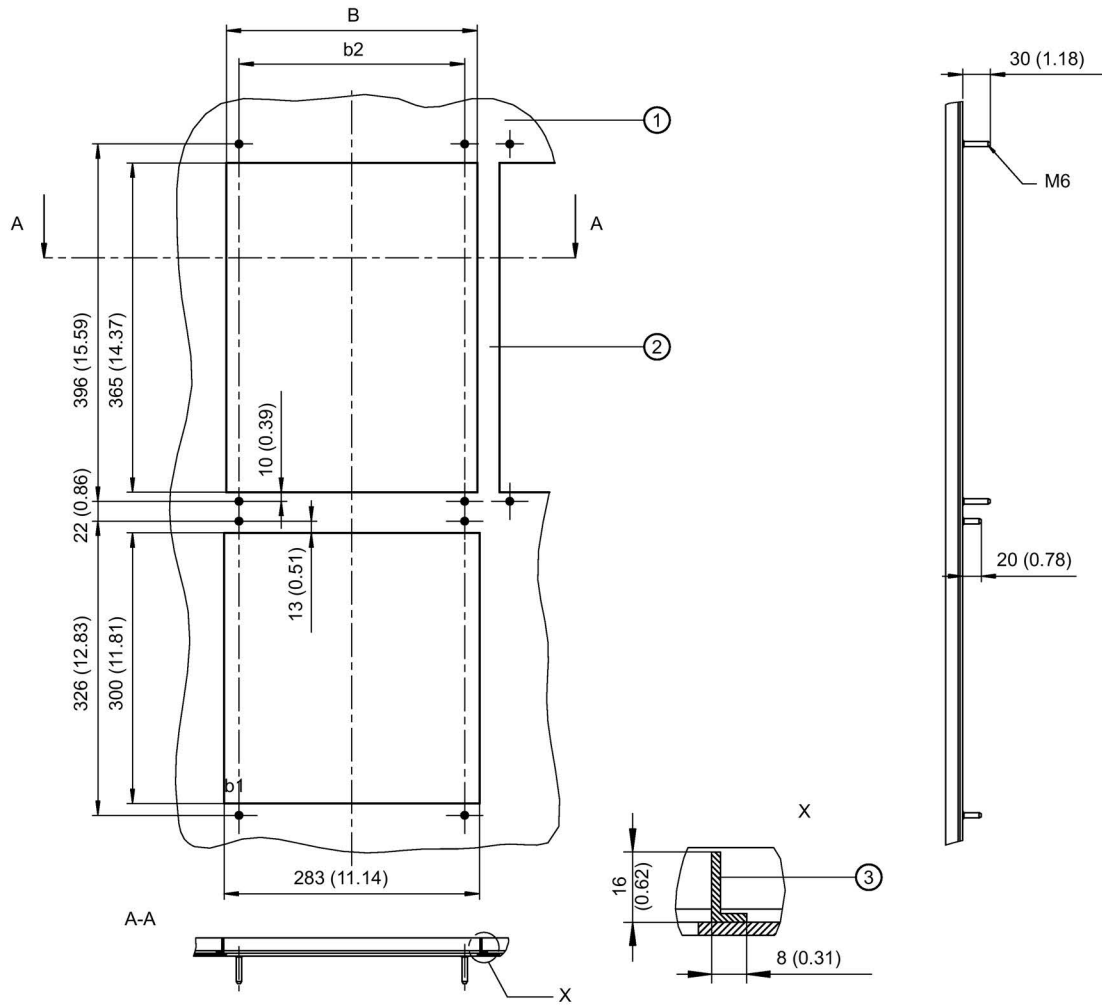

Figure 4-18 Openings to mount Active Line Modules 50 mm to 200 mm with external air cooling, all data in mm and (inches)



- ① Insert plate or mounting plate
- ② Cross-piece
- ③ Reinforcing bracket

Figure 4-19 Openings to mount an Active Line Module 300 mm with external air cooling, all data in mm and (inches)

Table 4- 21 Dimensions of openings to mount Active Line Modules with external air cooling

Component width	W [mm] (inch)	b1 [mm] (inch)	b2 [mm] (inch)
100 mm	89.5 ^{+0.3} (3.52 ^{+0.012})	19.75 ^{+0.15} (0.78 ^{+0.006})	50 ^{±0.15} (1.97 ^{±0.006})
150 mm	133 ^{+0.3} (5.24 ^{+0.012})	16.5 ^{+0.15} (0.65 ^{+0.006})	100 ^{±0.15} (3.94 ^{±0.006})
200 mm	173 ^{+0.3} (6.81 ^{+0.012})	11.5 ^{+0.15} (0.45 ^{+0.006})	150 ^{±0.15} (5.91 ^{±0.006})
300 mm	278 ^{+0.3} (10.94 ^{+0.012})	14.0 ^{±0.15} (0.55 ^{±0.006})	250 ^{+0.15} (9.84 ^{+0.006})

4.4.6.1 Mounting examples

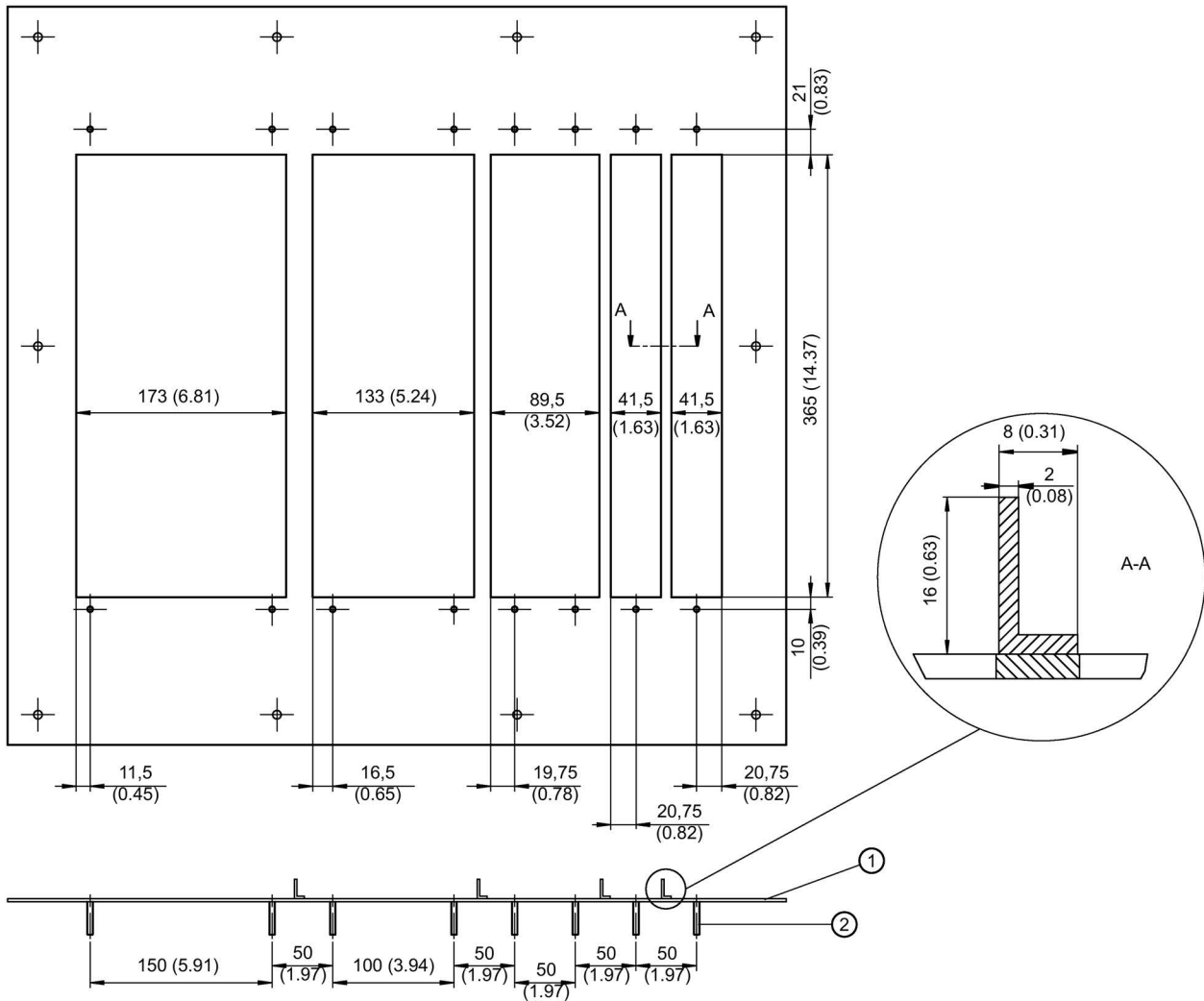

- ① Insert plate or mounting plate
- ② Threaded bolts M6 x 30

Figure 4-20 Example of a mounting plate for a drive line-up with external air cooling, all data in mm and (inch)

When mounting it must be ensured that the component's seal is tight throughout. The cross-pieces must have the appropriate stability. If necessary, the cross-pieces of the openings must be reinforced.

In the example, the cross-pieces have been reinforced using brackets according to EN 755-9. You are free to select the way that the bracket is attached to the insert.

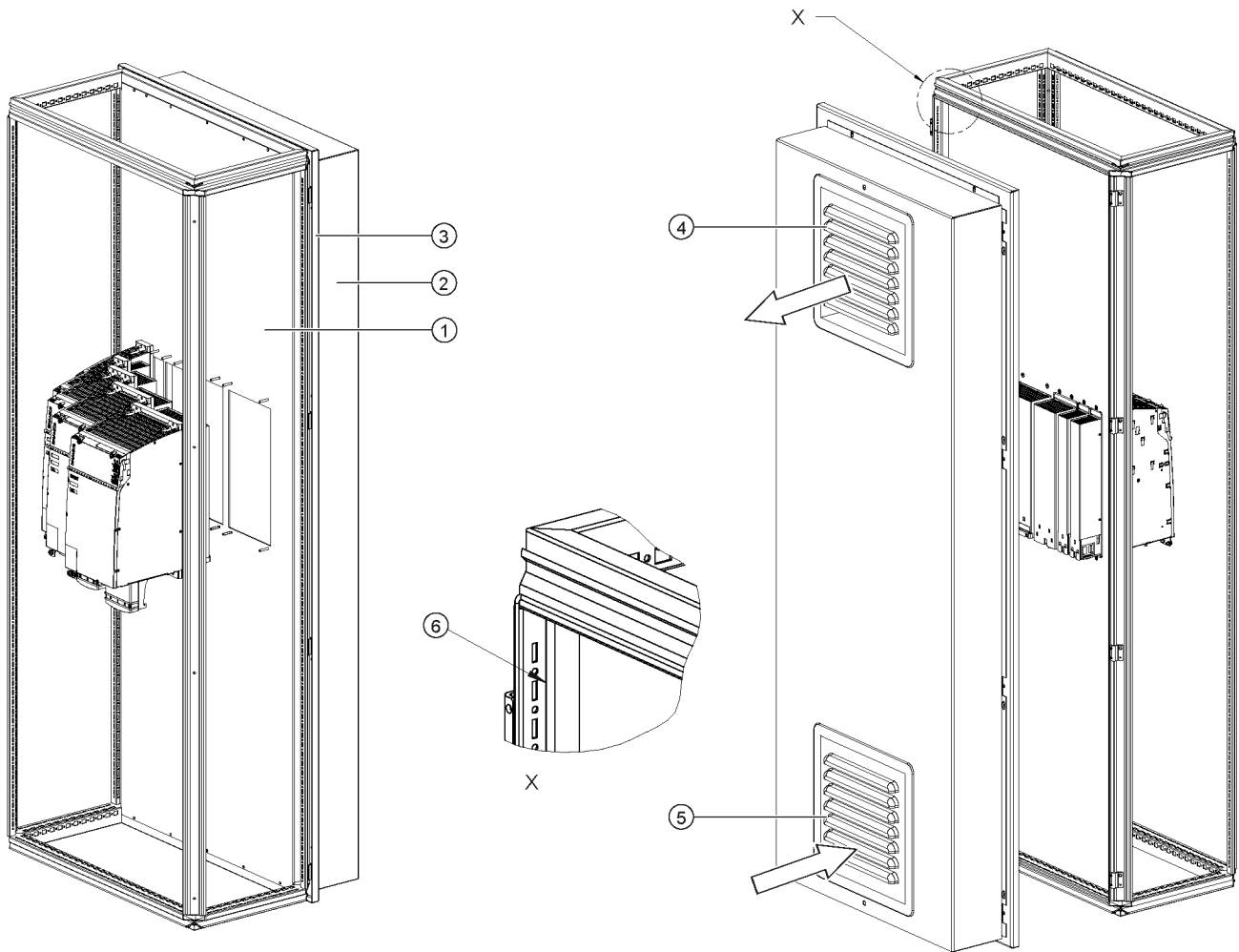

- ① Mounting plate
- ② Cover
- ③ Rear panel
- ④ Air discharge
- ⑤ Air inlet - filter with filter fan
- ⑥ To comply with degree of protection IP54, the surfaces ⑥ between the mounting plate and the cabinet strip must be sealed all round the circumference (e.g. Terostat-91 sealant from the Teroson company).

Figure 4-21 Example 1: mounting in the cabinet with mounting plate

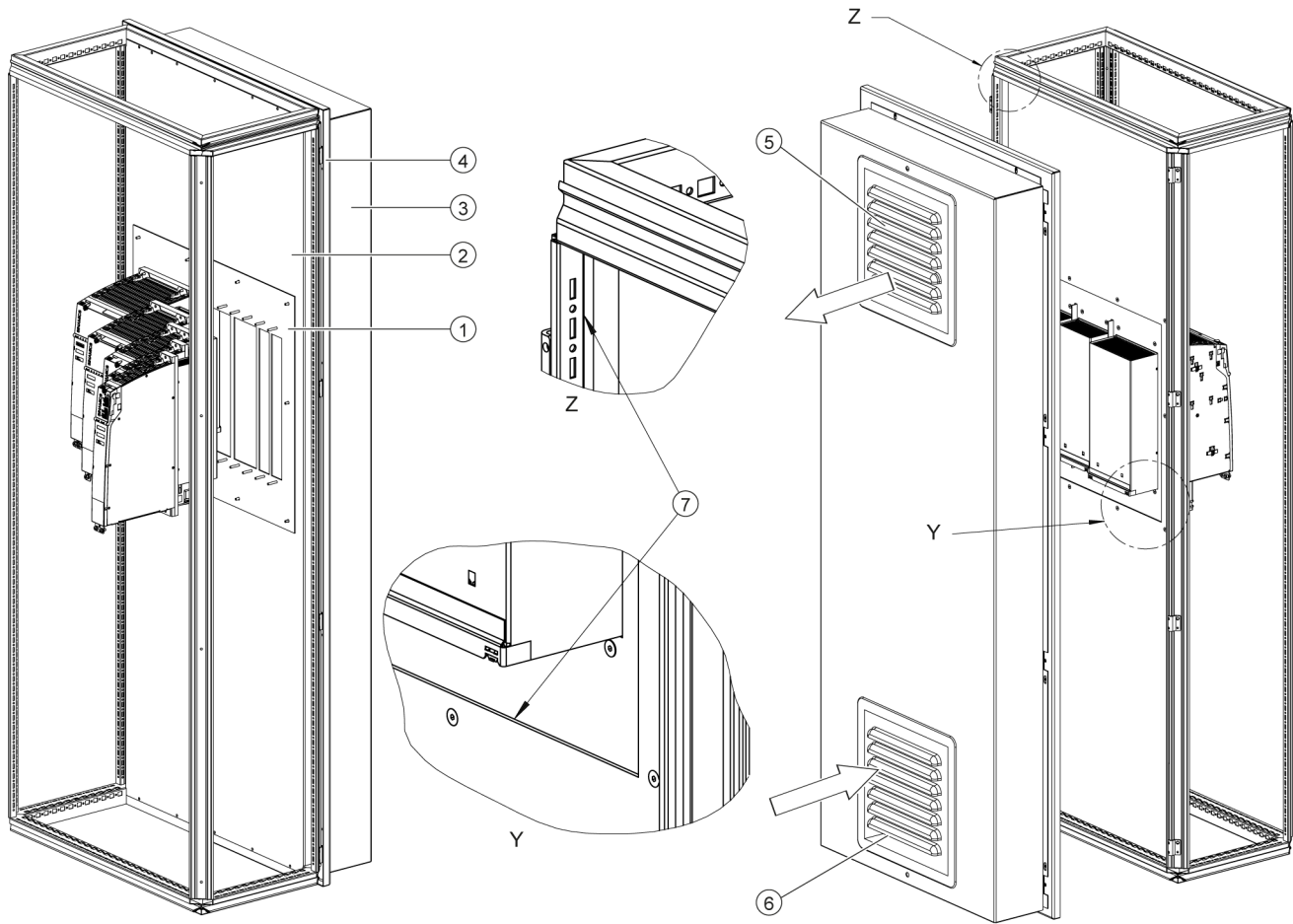

- ① Insert plate
- ② Mounting plate
- ③ Cover
- ④ Rear panel
- ⑤ Air discharge
- ⑥ Air inlet - filter with filter fan
- ⑦ To comply with degree of protection IP54, the surfaces ⑥ Between the mounting plate and the cabinet strip must be sealed all round the circumference (e.g. Terostat-91 sealant from the Teroson company).

Figure 4-22 Example 2: mounting in the cabinet with mounting plate

We recommend that you attach a cover and filter fan to the cabinet.

The filtered fan must be fitted in such a way that the cooling air required by the drive line-up is not restricted. The overall cooling air requirement is obtained from the sum of the individual components (see Chapter Technical data (Page 173)).

Note

If the cooling air requirement is not covered by the filtered fan, the components cannot output their specified power.

The filters with filter fan must be regularly checked for dirt and cleaned if necessary.

4.4.7 Technical data

Table 4- 22 Technical data for Active Line Modules with external air cooling, part 1

External air cooling	6SL3131-	7TE21-6AA.	7TE23-6AA.	7TE25-5AA.	7TE25-5AA3 + Active Inter- face Module
Rated power	kW	16	36	55	55
Infeed¹⁾					
Rated power S1 duty	kW (P_n)	16	36	55	55
Infeed power S6 duty (40 %)	kW (P_{S6})	21	47	71	71
Peak infeed power	kW (P_{max})	35	70	91	110
Regenerative feedback					
Continuous regenerative power	kW	16	36	55	55
Peak regenerative power	kW	35	70	91	110
Supply voltages		3 AC 380 ... 480 \pm 10 % (15 % < 1 min)			
Line voltage	V_{ACrms}	47 ... 63 Hz			
Line frequency	Hz	24 (20.4 ... 28.8)			
Electronics power supply	V_{DC}				
DC-link voltage	V_{DC}	510 ... 720			
Overvoltage trip	V_{DC}	820 \pm 2 %			
Undervoltage trip ²⁾	V_{DC}	360 \pm 2 %			
Input currents					
Rated input current: for AC 400 V	A_{AC}	25	55	84	84
input current: for AC 380 V / AC 480 V	A_{AC}	26 / 21	58 / 46	88 / 70	88 / 70
for AC 400 V; S6 duty (40 %)	A_{AC}	32	71	108	108
for AC 400 V; peak current	A_{AC}	54	107	139	168
DC link currents					
Rated DC link current: at 600 V DC	A_{DC}	27	60	92	92
at 510 V DC / 720 V DC	A_{DC}	27 / 22.2	60 / 50	92 / 76.4	92 / 76.4
DC-link current: for 600 V DC; S6 duty (40 %)	A_{DC}	35	79	121	121
for 600 V DC; peak current	A_{DC}	59	117	152	176
Current carrying capacity					
DC link busbars	A_{DC}	100	200	200	200
Reinforced DC link busbars	A_{DC}	150	--	--	--
24 V DC busbars	A_{DC}	20	20	20	20
Electronics current consumption					
at 24 V DC	A_{DC}	0.95	1.5	1.9	1.9

4.4 Active Line Modules with external air cooling

External air cooling	6SL3131-	7TE21-6AA.	7TE23-6AA.	7TE25-5AA.	7TE25-5AA3 + Active Interface Module
Rated power	kW	16	36	55	55
Total power loss (including electronics losses, see Power loss tables (Page 734))	W	282.8	666	945.6	945.6
DC link capacitance Active Line Module	μF	705	1410	1880	1880
Drive line-up, max.	μF	20000	20000	20000	20000
Power factor	$\cos \varphi$	1	1	1	1
Circuit breaker (IEC 60947 and UL)		See Chapter Overcurrent protection using fuses and circuit breakers (Page 47)			
Max. total cable length³⁾		See Chapter Combination options, Line Modules with line reactors and line filters (Page 120)			
Sound pressure level	dB(A)	< 60	< 65	< 60	< 60
Cooling air requirement	m ³ /h	56	112	160	160
Max. permissible heat sink temperature	°C	85	90	88	88
Ventilation clearances above/below	mm	≥ 80			
Rated voltage for rated data 3 AC 380 V					
Weight	kg	8.78	14.0	20.5	20.5

- 1) The specified power ratings apply to the line voltage range from 380 V to 480 V.
- 2) Default for 400 V line systems; undervoltage trip threshold is adjusted to the parameterized rated voltage
- 3) Maximum total cable length = Σ motor cables, line feeder cable from line filter to the Line Module

Table 4- 23 Technical data for Active Line Modules with external air cooling, part 2

External air cooling	6SL3131-	7TE28-0AA.	7TE31-2AA.
Rated power	kW	80	120
Infeed¹⁾			
Rated power S1 duty	kW (P_n)	80	120
Infeed power S6 duty (40 %)	kW (P_{S6})	106	145
Peak infeed power	kW (P_{max})	131	175
Regenerative feedback			
Continuous regenerative power	kW	80	120
Peak regenerative power	kW	131	175
Supply voltages		3 AC 380 ... 480 $\pm 10\%$ (- 15 % < 1 min)	
Line voltage	V_{ACrms}	47 ... 63 Hz	
Line frequency	Hz	24 (20.4 ... 28.8)	
Electronics power supply	V_{DC}	510 ... 720	
DC-link voltage	V_{DC}	820 $\pm 2\%$	
Overvoltage trip	V_{DC}	360 $\pm 2\%$	
Undervoltage trip ²⁾	V_{DC}	360 $\pm 2\%$	

External air cooling	6SL3131-	7TE28-0AA.	7TE31-2AA.
Rated power	kW	80	120
Input currents Rated input current at AC 400 V	A _{AC}	122	182
Input current at AC 380 V / AC 480 V	A _{AC}	128 / 102	192 / 152
at AC 400 V; S6 duty (40 %)	A _{AC}	161	220
at AC 400 V; peak current	A _{AC}	200	267
DC-link currents Rated DC-link current at 600 V DC	A _{DC}	134	200
at 510 V DC / 720 V DC	A _{DC}	134 / 111	200 / 167
DC-link current: for 600 V DC; S6 duty (40 %)	A _{DC}	176	244
for 600 V DC; peak current	A _{DC}	218	292
Current carrying capacity DC link busbars	A _{DC}	200	200
24 V busbars	A _{DC}	20	20
Electronics current consumption at 24 V DC	A _{DC}	1.4	1.8
Total power loss (including electronics losses, see Power loss tables (Page 734))	W	1383.6	2243.2
DC link capacitance Active Line Module	μF	2820	3995
Drive line-up, max.	μF	20000	20000
Power factor	cos φ	1	1
Circuit breaker (IEC 60947 and UL)		See Chapter Overcurrent protection using fuses and circuit breakers (Page 47)	
Max. total cable length³⁾		See Chapter Combination options, Line Modules with line reactors and line filters (Page 120)	
Sound pressure level	dB(A)	< 73	< 73
Cooling air requirement	m ³ /h	520	520
Max. permissible heat sink temperature		73	83
Ventilation clearances above/below	mm		≥ 80
in front of the fan	mm		≥ 50
Rated voltage for rated data 3 AC 380 V			
Weight	kg	27.66	30.74

1) The specified power ratings apply to the line voltage range from 380 V to 480 V.

2) Default for 400 V line systems; undervoltage trip threshold is adjusted to the parameterized rated voltage

3) Maximum total cable length = Σ motor cables, line feeder cable from line filter to the Line Module

4.4.7.1 Characteristics

Rated duty cycles for Active Line Modules

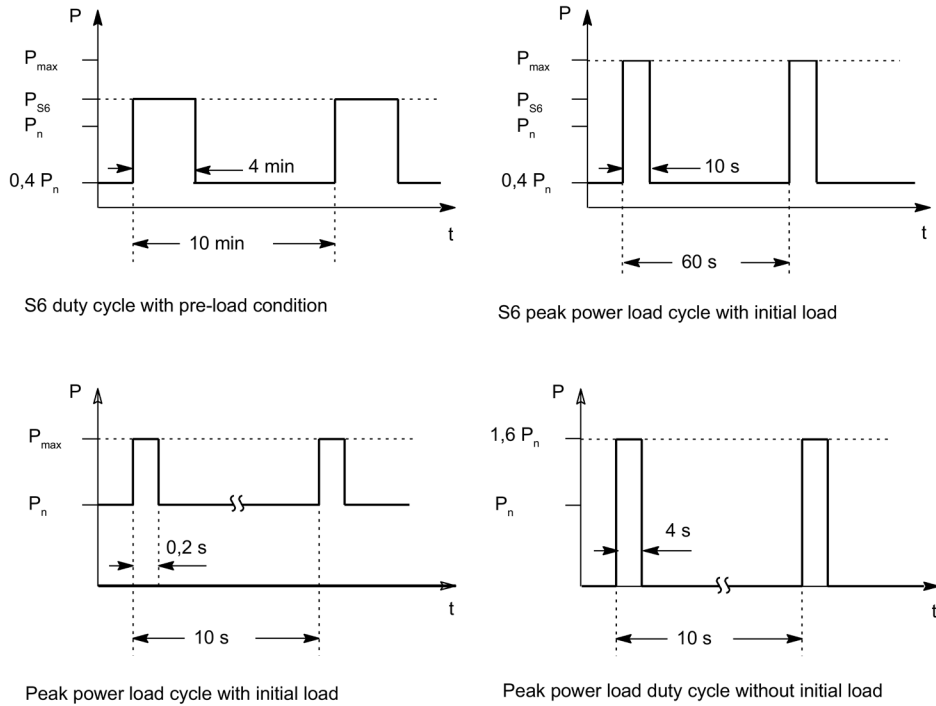

Figure 4-23 Rated duty cycles for Active Line Modules (**exception:** not applicable for 55 kW Active Line Module with Active Interface Module)

Rated duty cycles for Active Line Modules with Active Interface Modules

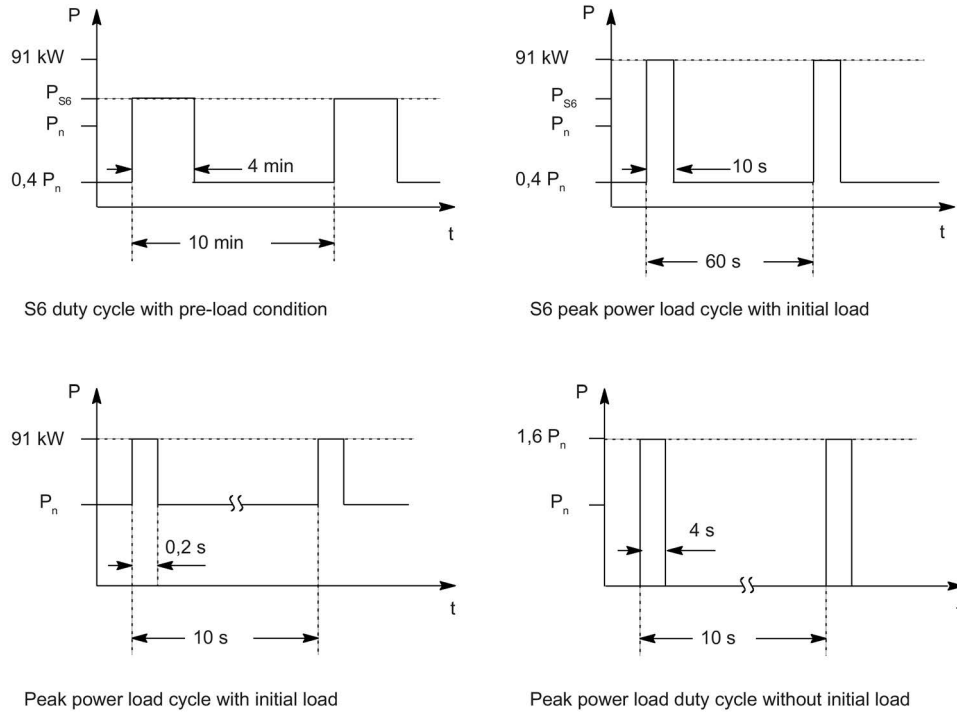

Figure 4-24 Load cycles for 55 kW Active Line Modules with Active Interface Module

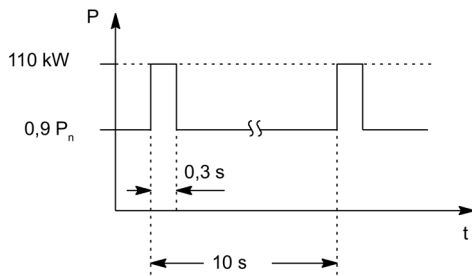

Figure 4-25 Peak load cycle with initial load for 55 kW Active Line Modules with Active Interface Module

4.5 Active Line Modules with cold plate

4.5.1 Description

Active Line Modules generate a constant, regulated DC voltage in the DC link from the 3-phase line supply voltage that supplies the connected Motor Modules with power.

This ensures that they are not influenced by line voltage fluctuations.

When motors brake, Active Line Modules feed energy back into the line supply. The regenerative feedback capability of the modules can be deactivated by parameterization.

The DC link starts precharging as soon as the line voltage is applied and is independent of its phase sequence direction. Load can be applied to the DC link after the module has been enabled.

A line contactor can be installed on the line side if the system has to be electrically isolated from the line supply.

Active Line Modules can be directly connected to TN, IT and TT systems. The Line Modules have an integrated overvoltage protection function.

4.5.2 Interface description

4.5.2.1 Overview

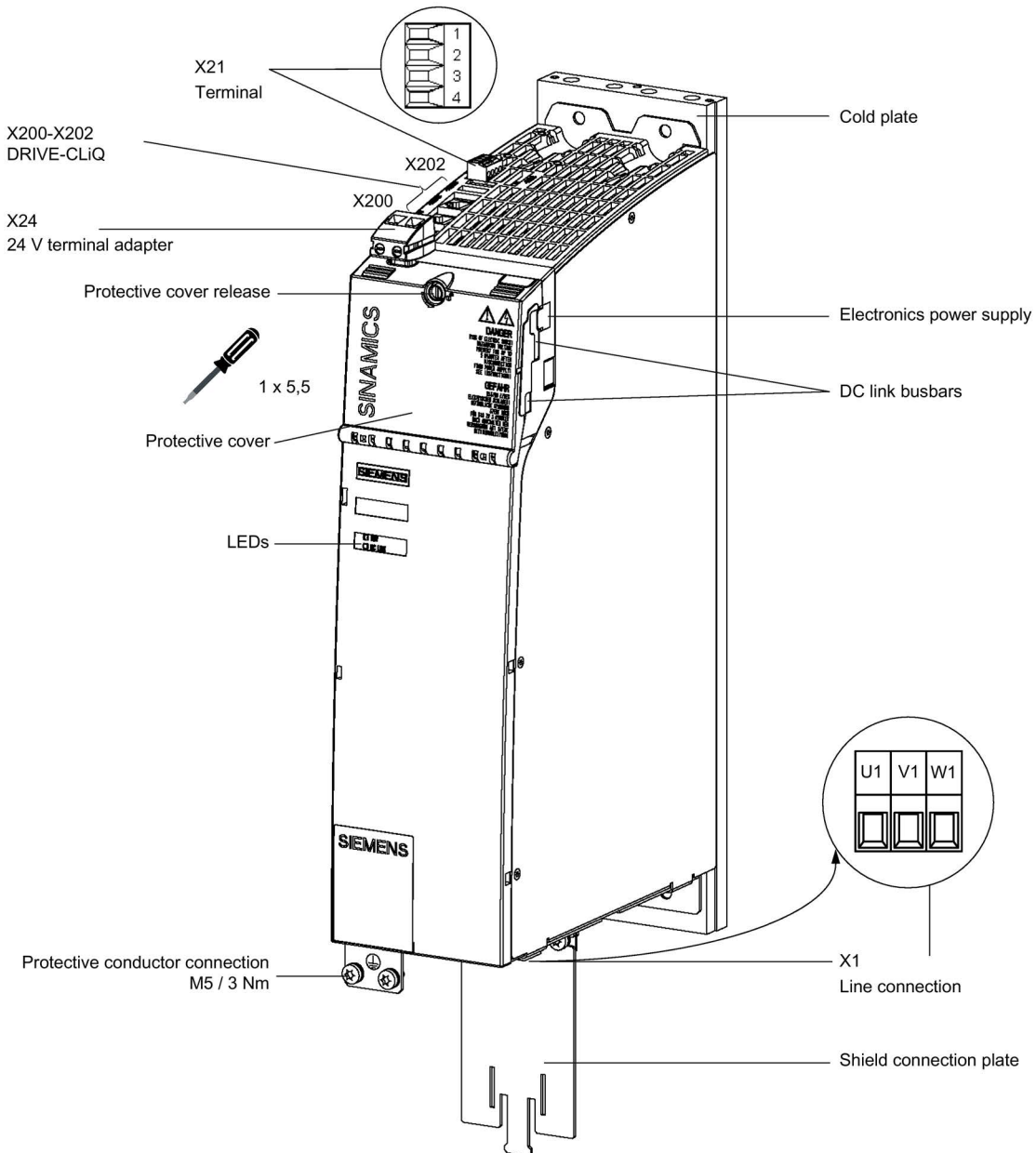

Figure 4-26 Interface overview, Active Line Module with cold plate (example: 16 kW)

4.5 Active Line Modules with cold plate

4.5.2.2 X1 line connection

Table 4- 24 X1: Line connection for Active Line Modules 16 kW

	Terminal	Technical data
	U1	Type: Screw terminal 6 (Page 708)
	V1	
	W1	
	Protective conductor connection	Threaded hole M5 / 3 Nm (26.6 lbf in) ¹⁾
¹⁾ For ring cable lugs without insulation (Page 710)		

Table 4- 25 X1: Line supply connection for Active Line Modules 36 kW to 120 kW

	Terminal	Technical data
	U1	Supply voltage: 380 ... 480 V 3 AC, 50/60 Hz 36 kW: Threaded bolt M6 / 6 Nm (53.1 lbf in) ¹⁾ 55 kW, 80 kW and 120 kW: Threaded bolt M8 / 13 Nm (115 lbf in) ¹⁾
	V1	
	W1	
	Protective conductor connection	36 kW and 55 kW: Threaded hole M6 / 6 Nm (53.1 lbf in) ¹⁾
		80 kW and 120 kW: Threaded hole M8 / 13 Nm (115 lbf in) ¹⁾
¹⁾ For ring cable lugs without insulation (Page 710)		

4.5.2.3 X21 EP terminals

Table 4- 26 X21 EP terminal / temperature sensor

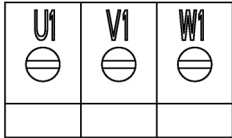
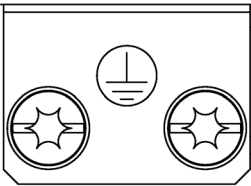
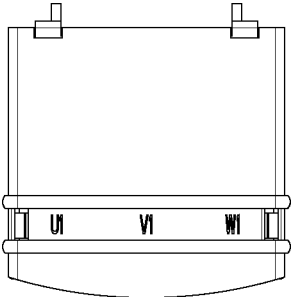
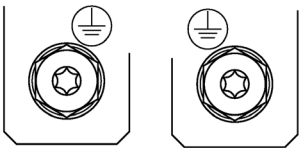
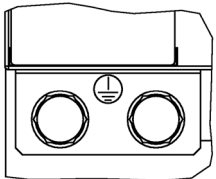
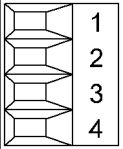
	Terminal	Designation	Technical data
	1	+ Temp	Temperature sensors ¹⁾ : KTY84–1C130 ²⁾ / PT1000 ²⁾ / PTC ²⁾ / bimetallic switch with NC contact If an Active Interface Module is used, the temperature input must be connected to the Active Interface Module sensor (bimetallic switch with NC contact).
	2	- Temp	
	3	EP +24 V (pulse enable)	Voltage: 24 V DC (20.4 ... 28.8 V) Current consumption, typical: 4 mA at 24 V Isolated input
	4	EP M (Enable Pulses)	

Type: Screw terminal 1 (Page 708)

1) The temperature sensor type and the temperature output can be selected by parameter (see the SINAMICS S120/S150 List Manual).

2) Temperatures are detected but not evaluated in the Active Line Module.

Terminals X21.1 and X21.2

When using an Active Interface Module, its temperature output must be connected at terminals X21.1 and X21.2.

Terminals X21.3 and X21.4

For operation, the 24 V DC voltage must be connected to terminal X21.3 and ground to terminal X21.4.

Pulse cancellation is activated if the power supply is disconnected. As a consequence, regenerative feedback is deactivated and the bypass relay drops out. If the Line Module is not disconnected from the line supply when the EP terminal is de-energized, for example, because a line contactor is not installed, then the DC link remains charged.



WARNING

Electric shock in the event of voltage flashovers at the temperature sensor

Voltage flashovers in the signal electronics can occur in motors without safe electrical separation of the temperature sensors.

- Use temperature sensors that comply with the specifications relating to protective separation.
- If safe electrical separation cannot be guaranteed (for linear motors or third-party motors, for example), use a Sensor Module External (SME120 or SME125) or Terminal Module TM120.

4.5.2.4 X24 24 V terminal adapter

Table 4- 27 X24: 24 V terminal adapter

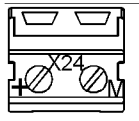
	Terminal	Designation	Technical data
	+	24 V power supply	24 V DC supply voltage
	M	Ground	Electronics ground
Type: Screw terminal 5 (Page 708)			

The 24 V terminal adapter is included in the scope of supply.

4.5.2.5 X200-X202 DRIVE-CLiQ interfaces

Table 4- 28 X200-X202: DRIVE-CLiQ interfaces

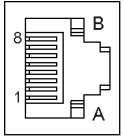
	PIN	Signal name	Technical data
	1	TXP	Transmit data +
	2	TXN	Transmit data -
	3	RXP	Receive data +
	4	Reserved, do not use	-
	5	Reserved, do not use	-
	6	RXN	Receive data -
	7	Reserved, do not use	-
	8	Reserved, do not use	-
	A	+(24 V)	24 V power supply
	B	M (0 V)	Electronics ground

The blanking covers for the DRIVE-CLiQ interfaces are included in the scope of delivery.

Blanking cover (50 pcs.) Article number: 6SL3066-4CA00-0AA0

4.5.3 Connection example

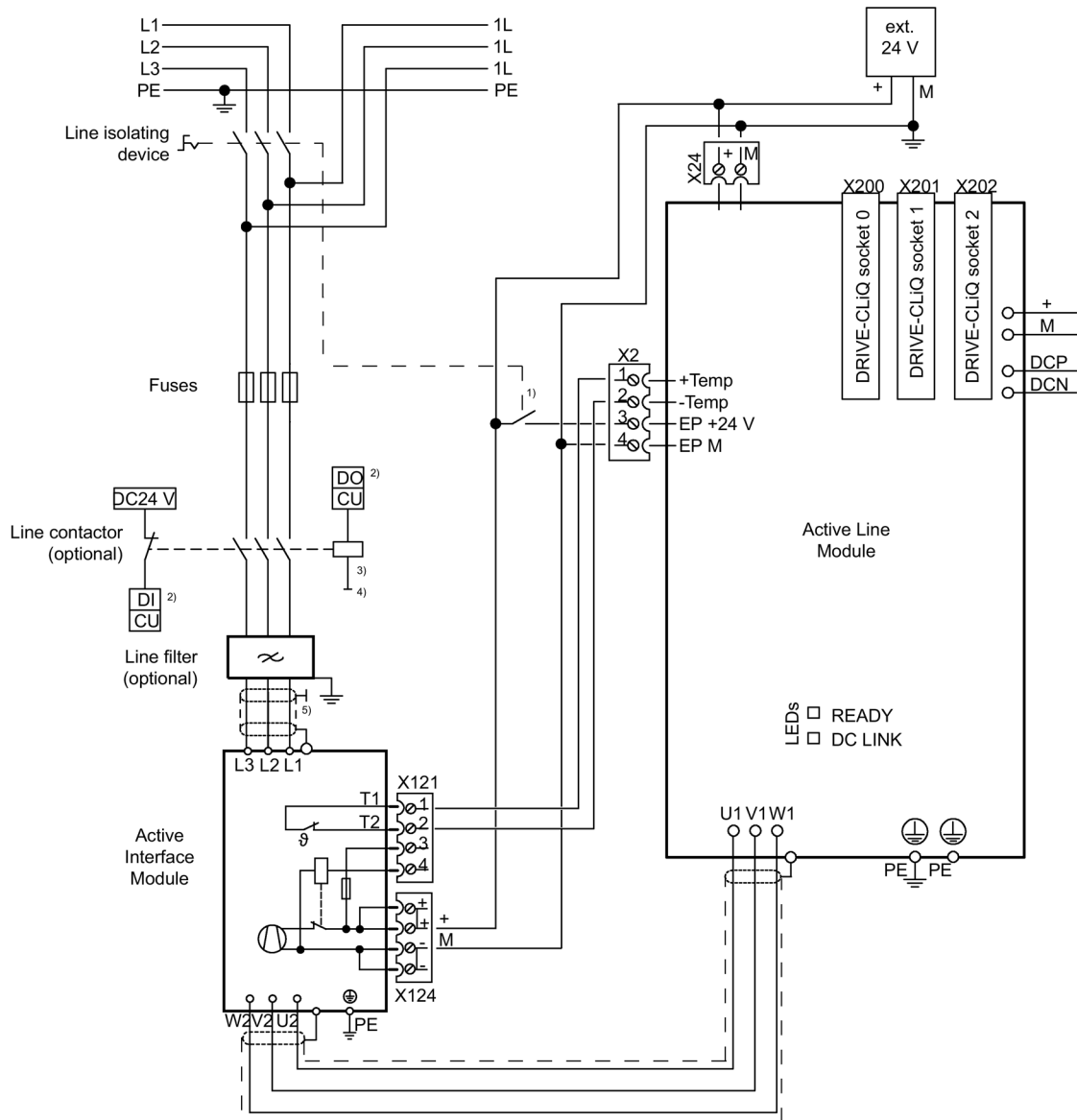

¹⁾ Leading opening contact $t > 10$ ms

²⁾ DI/DO, controlled by the Control Unit.

³⁾ No additional load permitted downstream of the line contactor!

⁴⁾ The current carrying capacity of the DO must be observed; an output coupling device may have to be used.

⁵⁾ Contact established through the rear mounting panel or shield rails in accordance with the EMC Directive.

Figure 4-27 Connection example: Active Line Module with cold plate

Note

If you are using a VSM10 Voltage Sensing Module, the leading opening contact can be omitted.

4.5.4 Meaning of LEDs

Table 4- 29 Meaning of the LEDs on the Active Line Module

Status		Description, cause	Remedy
RDY	DC LINK		
off	off	The electronics power supply is missing or outside the permissible tolerance range.	–
Green	-- ¹⁾	The component is ready for operation. Cyclic DRIVE-CLiQ communication is established.	–
	Orange	The component is ready for operation. Cyclic DRIVE-CLiQ communication is established. The DC link voltage is present.	–
	Red	The component is ready for operation. Cyclic DRIVE-CLiQ communication is established. The DC link voltage is outside the permissible tolerance range.	Check the line supply voltage.
Orange	Orange	DRIVE-CLiQ communication is being established.	–
Red	-- ¹⁾	This component has at least one fault.	Resolve and acknowledge the fault.
Green/ red (0.5 Hz)	-- ¹⁾	Firmware is being downloaded.	–
Green/red (2 Hz)	-- ¹⁾	Firmware download has been completed. The system waits for POWER ON.	Carry out a POWER ON.
Green/orange or red/orange	-- ¹⁾	Component recognition via LED is activated ²⁾ . Note: Both options depend on the LED status when component recognition is activated.	–

¹⁾ Irrespective of the status of the LED "DC LINK"

²⁾ For information about activating the parameter "Recognition via LED", see SINAMICS S120/S150 List Manual

4.5.5 Dimension drawings

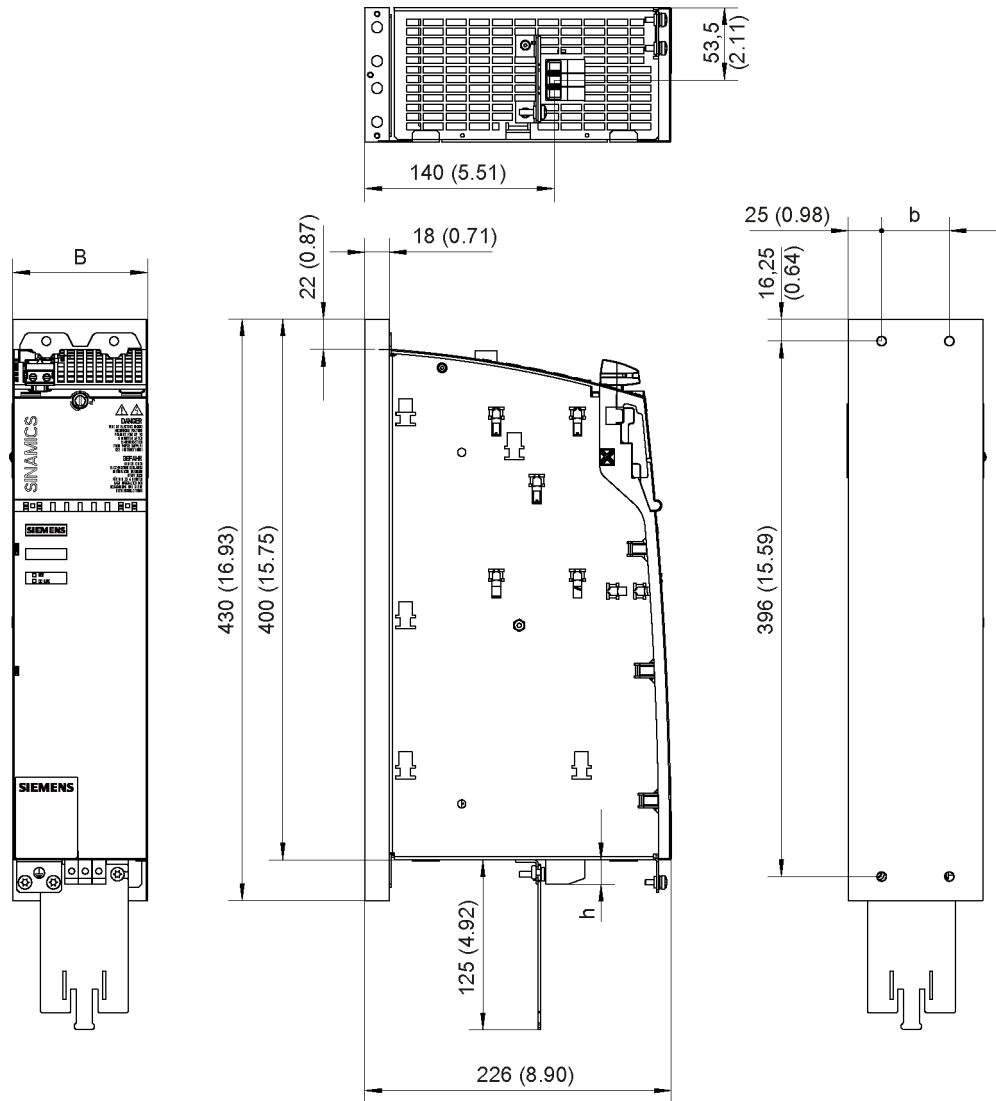

Figure 4-28 Dimension drawing of 16 kW Active Line Module with cold plate, all dimensions in mm and (inches)

Table 4- 30 Dimensions of 16 kW Active Line Module with cold plate

Active Line Module	Article No.	B [mm] (inch)	b [mm] (inch)	h [mm] (inch)
16 kW	6SL3136-7TE21-6AA.	100 (3.94)	50 (1.97)	18 (0.71)

4.5 Active Line Modules with cold plate

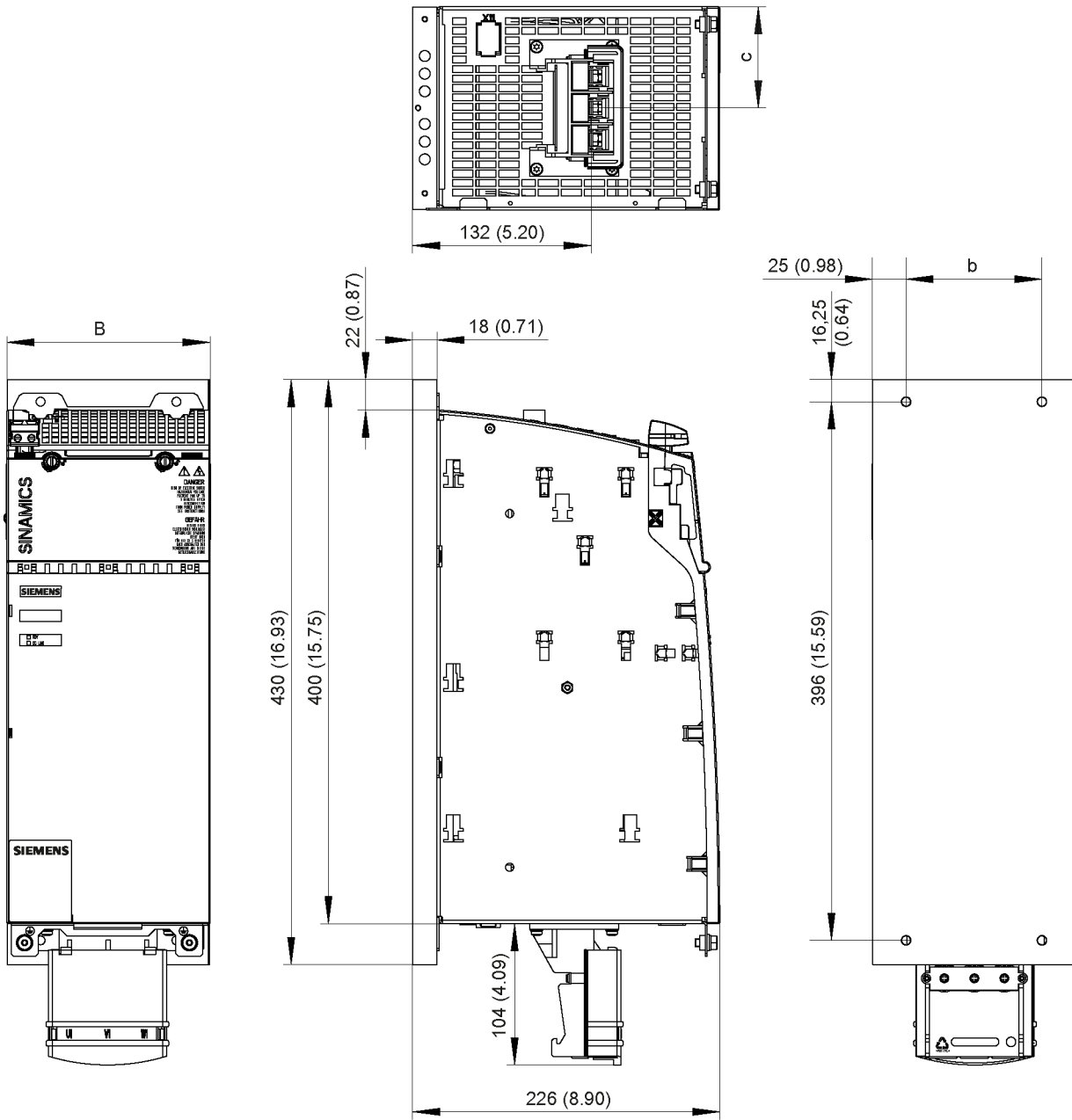

Figure 4-29 Dimension drawing of 36 kW, 55 kW, 80 kW, and 120 kW Active Line Modules with cold plate, all dimensions in mm and (inches)

Table 4- 31 Dimensions of 36 kW, 55 kW, 80 kW, and 120 kW Active Line Modules with cold plate

Active Line Module	Article No.	B [mm] (inch)	b [mm] (inch)	c [mm] (inch)
36 kW	6SL3136-7TE23-6AA.	150 (5.91)	100 (3.94)	75 (2.95)
55 kW	6SL3136-7TE25-5AA.	200 (7.87)	150 (5.91)	100 (3.94)
80 kW	6SL3136-7TE28-0AA.	300 (11.81)	250 (9.84)	150 (5.91)
120 kW	6SL3136-7TE31-2AA.	300 (11.81)	250 (9.84)	150 (5.91)

4.5.6 Mounting

Please note the following before mounting an Active Line Module with cold plate on a customer-specific heat sink:

- Check the surface of the heat sink to ensure that it is not damaged.
- To improve heat transfer, a heat-conducting medium must be used. Special spherical-indented heat-conducting foil must be used for this purpose. Every component with cold plate is supplied with heat-conducting foil cut to the right size. The position of the heat conducting foil should be carefully taken into account (see Fig. "Mounting an Active Line Module with cold plate on an external heat sink").

Note

Use heat conducting foil

- Also replace the heat-conducting foil when replacing a component.
 - Only use heat-conducting foil released or supplied by Siemens.
-

Table 4- 32 Overview of heat-conducting foils

	Article No.
Heat-conducting foil, 100 mm	6SL3162-6FD00-0AA0
Heat-conducting foil, 150 mm	6SL3162-6FF00-0AA0
Heat-conducting foil, 200 mm	6SL3162-6FH00-0AA0
Heat-conducting foil, 300 mm	6SL3162-6FM00-0AA0

Note

To mount the components, M6 threaded bolts and hexagon nuts/grub screws ISO 7436-M6x40-14 H, property class 8.8 are recommended.

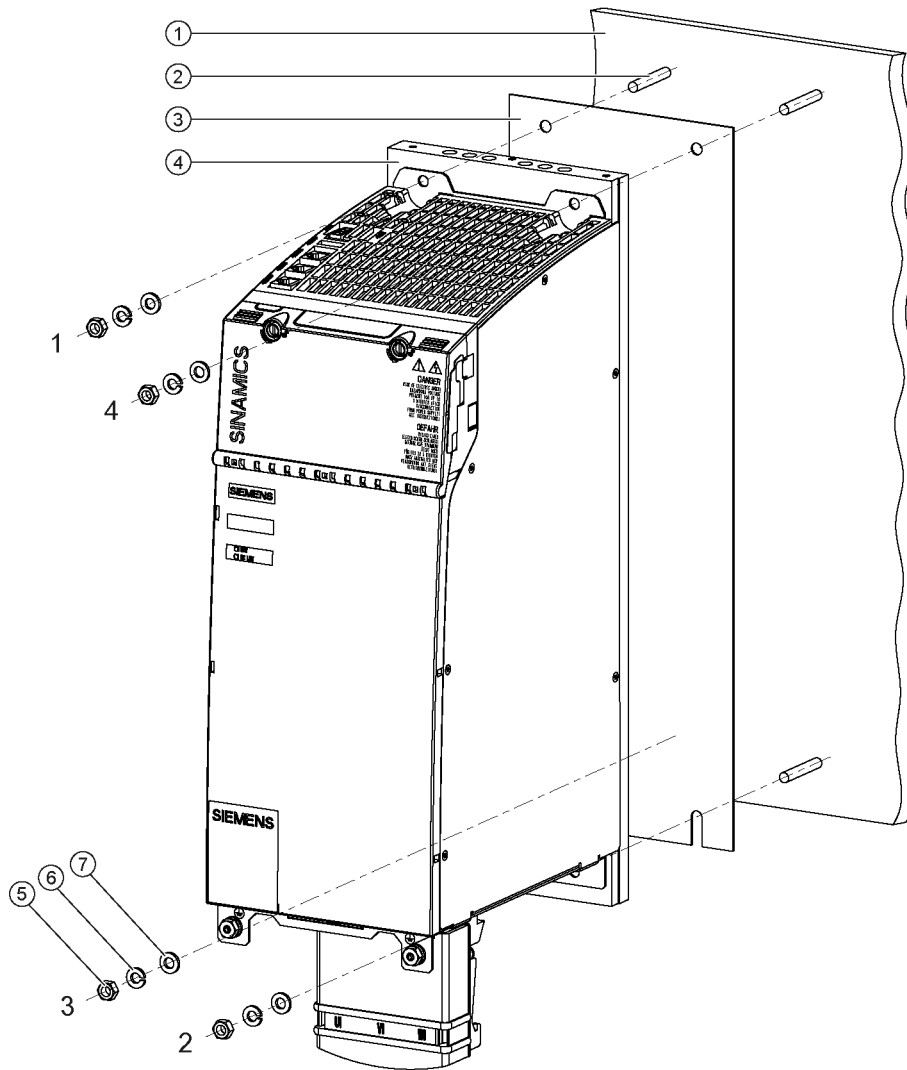

- ① External heat sink (air or liquid)
- ② Threaded bolts M6
- ③ Heat-conducting foil
- ④ Cold plate
- ⑤ M6 nut
- ⑥ Spring washer
- ⑦ Washer

Figure 4-30 Mounting an Active Line Module with cold plate on an external heat sink (example: 36 kW)

Tightening torques:

1. Firstly, tighten the nuts by hand.
Tightening torque: 0.5 Nm (4.4 lbf in)
2. Then tighten the nuts in the specified sequence 1 to 4.
Tightening torque: 10 Nm (88.5 lbf in)

Support with the mechanical control cabinet design is available from:

Siemens AG
Digital Factory, DF MC MF - WKC AS
TCCC (Technical Competence Center Cabinets Chemnitz)
Postfach 1124
09070 Chemnitz
e-mail: cc.cabinetcooling.aud@siemens.com

Properties of the heat sink

We recommend using AlMgSi 0.5 as the heat sink material.
The roughness of the external heat sink surface should be at least Rz 16. The contact surface between the heat sink and cold plate should have an evenness of 0.2 mm (applicable to a height of 450 mm and a width of 300 mm).

Note

Machine manufacturers can adapt the heat sink version to their special requirements. The specified rated data for the Line Modules can only be achieved if the power losses can be dissipated by the external heat sink under the specified general conditions.

NOTICE**Damage to the cold plate caused by incorrect mounting**

The threaded bolts can damage the cold plate when it is being mounted.

- Do not damage the cold plate.

4.5.7 Technical data

Table 4- 33 Technical data for Active Line Modules with cold plate cooling

Cold plate	6SL3136-7TE	21-6AA.	23-6AA.	25-5AA.	25-5AA3 + Active Interface Module	28-0AA.	31-2AA.
Rated power	kW	16	36	55	55	80 (64)¹⁾	120 (84)¹⁾
Infeed²⁾							
Rated power (S1)	kW (P _n)	16	36	55	55	80 (64) ¹⁾	120 (84) ¹⁾
Infeed power	kW (P _{S6})	21	47	71	71	106 (85) ¹⁾	145 (116) ¹⁾
S6 duty (40 %)							
Peak infeed power	kW (P _{max})	35	70	91	110	131	175
Regenerative feedback							
Continuous regenerative power	kW	16	36	55	55	80 (64) ¹⁾	120 (84) ¹⁾
Peak regenerative power	kW	35	70	91	110	131	175
Supply voltages		3 AC 380 ... 480 ±10 % (- 15 % < 1 min)					
Line voltage	V _{ACrms}	47 ... 63					
Line frequency	Hz	24 (20.4 ... 28.8)					
Electronics power supply	V _{DC}	510 ... 720					
DC-link voltage	V _{DC}	820 ± 2 %					
Overvoltage trip	V _{DC}	360 ± 2 %					
Undervoltage trip ³⁾	V _{DC}						
Input currents							
Rated input current:							
for AC 400 V	A _{AC}	25	55	84	84	122 (98) ¹⁾	182 (127) ¹⁾
input current:							
for AC 380 V	A _{AC}	26	58	88	88	128 (102) ¹⁾	192 (134) ¹⁾
for AC 480 V	A _{AC}	21	46	70	70	102 (82) ¹⁾	152 (106) ¹⁾
for AC 400 V; S6 (40 %)	A _{AC}	32	71	108	108	161 (129) ¹⁾	220 (154) ¹⁾
for AC 400 V; peak current	A _{AC}	54	107	139	168	200	267
DC link currents							
Rated DC link current:							
at 600 V DC	A _{DC}	27	60	92	92	134 (107) ¹⁾	200 (140) ¹⁾
at 510 V DC / 720 V DC	A _{DC}	27 / 22.2	60 / 50	92 / 76.4	92 / 76.4	134 (107) / 111 (89) ¹⁾	200 (140) / 167 (134) ¹⁾
DC-link current:							
at 600 V DC; S6 (40 %)	A _{DC}	35	79	121	121	176 (141) ¹⁾	244 (171) ¹⁾
at 600 V DC; peak current	A _{DC}	59	117	152	176	195	292
Current carrying capacity							
DC link busbars	A _{ACrms}	100	200	200	200	200	200
Reinforced DC link busbars	A _{ACrms}	150	--	--	--	--	--
24 V DC busbars	A _{ACrms}	20	20	20	20	20	20
Electronics current consumption							
at 24 V DC	A _{DC}	0.85	1.05	1.15	1.15	1.4	1.8

Cold plate	6SL3136-7TE	21-6AA.	23-6AA.	25-5AA.	25-5AA3 + Active Interface Module	28-0AA.	31-2AA.
Total power loss (including electronics losses, see Power loss tables (Page 734))	W	280.4	655.2	927.6	927.6	1383.6	2243.2
DC link capacitance Active Line Module	μF	710	1410	1880	1880	2820	3760
Drive line-up, max.	μF	20000	20000	20000	20000	20000	20000
Power factor	$\cos \varphi$	1	1	1	1	1	1
Circuit breaker (IEC 60947 and UL)		See Chapter Overcurrent protection using fuses and circuit breakers (Page 47)					
Max. total cable length⁴⁾		See Chapter Combination options, Line Modules with line reactors and line filters (Page 120)					
Max. permissible heat sink temperature	$^{\circ}\text{C}$	70	73	83	83	75	80
Ventilation clearances above/below	mm	≥ 80					
Weight	kg	6.1	10.3	14.4	14.4	20.3	20.4

- 1) Derating must be applied due to the transfer of heat to the external heat sink. At a temperature of 40°C at the interface to the power unit, 80% derating occurs for 6SL3136-7TE28-0AA. and 70 % for 6SL3136-7TE31-2AA.
- 2) The specified power ratings apply to the line voltage range from 380 V to 480 V.
- 3) Default for 400 V line systems; undervoltage trip threshold is adjusted to the parameterized rated voltage
- 4) Maximum total cable length = Σ motor cables, line feeder cable from line filter to the Line Module

Note

New systems with 80 kW and 120 kW Active Line Modules should ideally be designed with 120 kW Active Line Modules Liquid Cooled in order to avoid power derating.

4.5.7.1 Characteristics

Rated duty cycles for Active Line Modules

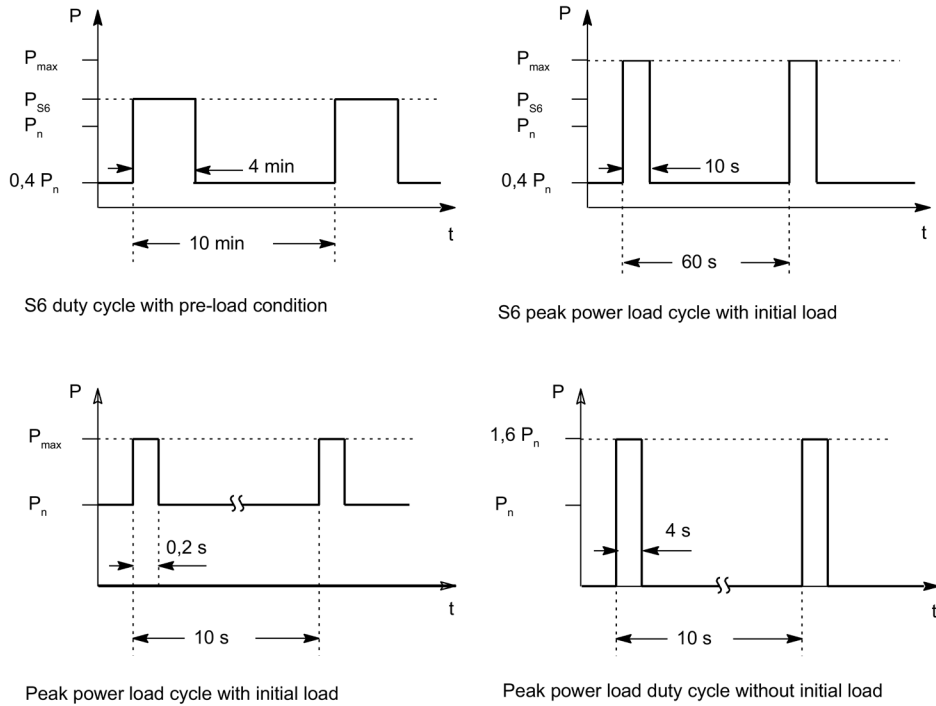

Figure 4-31 Rated duty cycles for Active Line Modules (**exception:** not applicable for 55 kW Active Line Module with Active Interface Module)

Rated duty cycles for Active Line Modules with Active Interface Modules

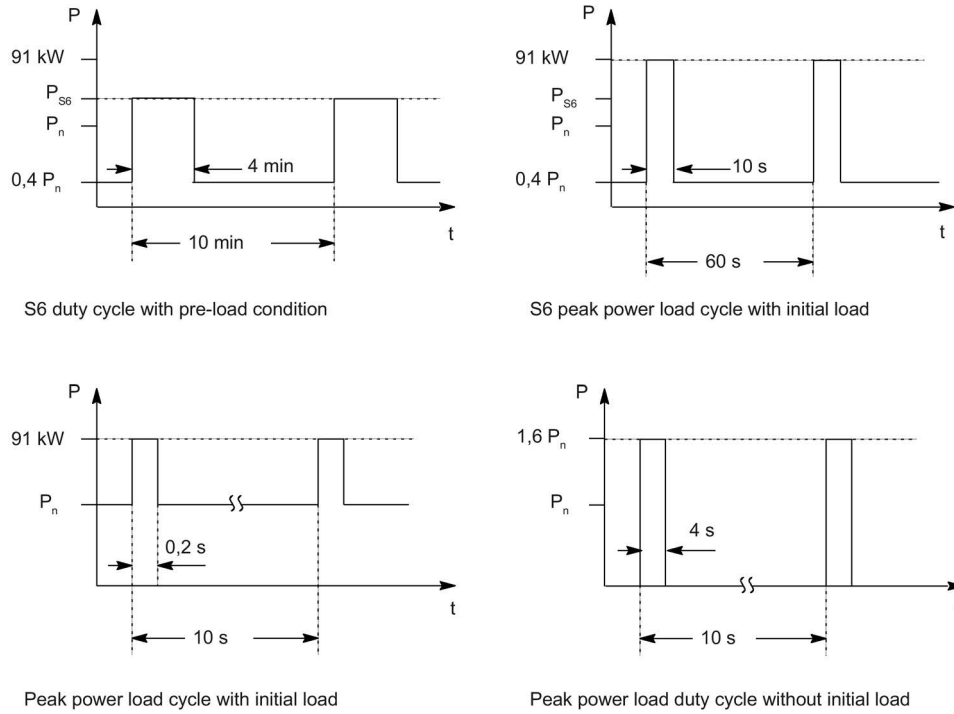

Figure 4-32 Load cycles for 55 kW Active Line Modules with Active Interface Module

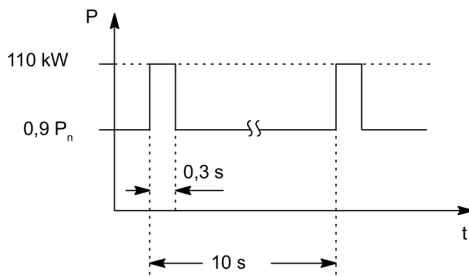

Figure 4-33 Peak load cycle with initial load for 55 kW Active Line Modules with Active Interface Module

4.6 Active Line Modules Liquid Cooled

4.6.1 Description

Active Line Modules generate a constant, regulated DC voltage in the DC link from the 3-phase line supply voltage that supplies the connected Motor Modules with power.

This ensures that they are not influenced by line voltage fluctuations.

When motors brake, Active Line Modules feed energy back into the line supply. The regenerative feedback capability of the modules can be deactivated by parameterization.

The DC link starts precharging as soon as the line voltage is applied and is independent of its phase sequence direction. Load can be applied to the DC link after the module has been enabled.

A line contactor can be installed on the line side if the system has to be electrically isolated from the line supply.

Active Line Modules can be directly connected to TN, IT and TT systems. The Line Modules have an integrated overvoltage protection function.

4.6.2 Interface description

4.6.2.1 Overview

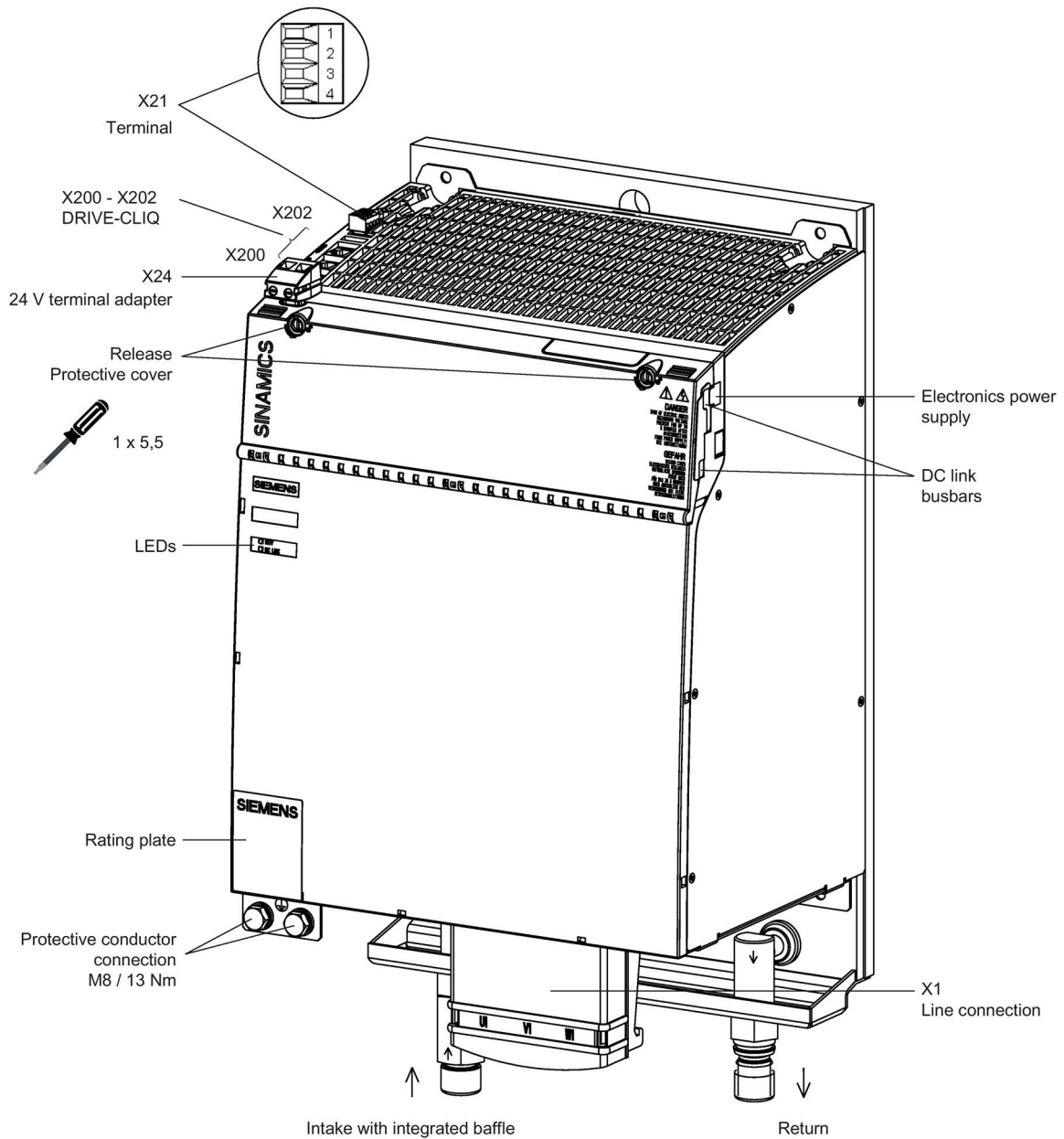
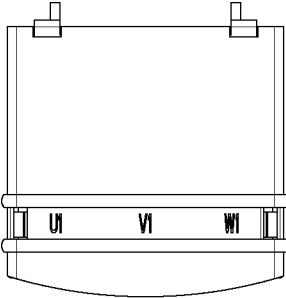
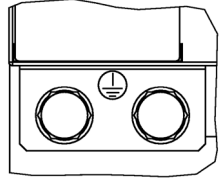

Figure 4-34 Interface overview, Active Line Module Liquid Cooled (120 kW)

4.6.2.2 X1 line connection

Table 4- 34 X1 line connection

	Terminals	Technical data
	U1	Supply voltage: 3 AC 380 V ... 480 V, 50 / 60 Hz Threaded bolt M8 / 13 Nm (115 lbf in) ¹⁾
	V1	
	W1	
	Protective conductor connection	Threaded hole M8 / 13 Nm (115 lbf in) ¹⁾
¹⁾ For ring cable lugs without insulation (Page 710)		

4.6.2.3 X21 EP terminals

Table 4- 35 X21 EP terminal / temperature sensor

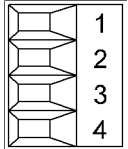
	Terminal	Designation	Technical data
	1	+ Temp	Temperature sensors ¹⁾ : KTY84–1C130 ²⁾ / PT1000 ²⁾ / PTC ²⁾ / bimetallic switch with NC contact If an Active Interface Module is used, the temperature input must be connected to the Active Interface Module sensor (bimetallic switch with NC contact).
	2	- Temp	
	3	EP +24 V (pulse enable)	Voltage: 24 V DC (20.4 ... 28.8 V)
	4	EP M (Enable Pulses)	Current consumption, typical: 4 mA at 24 V Isolated input
Type: Screw terminal 1 (Page 708)			

¹⁾ The temperature sensor type and the temperature output can be selected by parameter (see the SINAMICS S120/S150 List Manual).

²⁾ Temperatures are detected but not evaluated in the Active Line Module.

Terminals X21.1 and X21.2

When using an Active Interface Module, its temperature output must be connected at terminals X21.1 and X21.2.

Terminals X21.3 and X21.4

For operation, the 24 V DC voltage must be connected to terminal X21.3 and ground to terminal X21.4.

Pulse cancellation is activated if the power supply is disconnected. As a consequence, regenerative feedback is deactivated and the bypass relay drops out. If the Line Module is not disconnected from the line supply when the EP terminal is de-energized, for example, because a line contactor is not installed, then the DC link remains charged.

**! WARNING****Electric shock in the event of voltage flashovers at the temperature sensor**

Voltage flashovers in the signal electronics can occur in motors without safe electrical separation of the temperature sensors.

- Use temperature sensors that comply with the specifications relating to protective separation.
- If safe electrical separation cannot be guaranteed (for linear motors or third-party motors, for example), use a Sensor Module External (SME120 or SME125) or Terminal Module TM120.

4.6.2.4 X24 24 V terminal adapter

Table 4- 36 X24: 24 V terminal adapter

	Terminal	Designation	Technical data
	+	24 V power supply	24 V DC supply voltage
	M	Ground	Electronics ground

Type: Screw terminal 5 (Page 708)

The 24 V terminal adapter is included in the scope of supply.

4.6.2.5 X200-X202 DRIVE-CLiQ interfaces

Table 4- 37 X200-X202: DRIVE-CLiQ interfaces

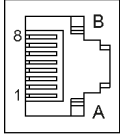
	PIN	Signal name	Technical data
	1	TXP	Transmit data +
	2	TXN	Transmit data -
	3	RXP	Receive data +
	4	Reserved, do not use	-
	5	Reserved, do not use	-
	6	RXN	Receive data -
	7	Reserved, do not use	-
	8	Reserved, do not use	-
	A	+(24 V)	24 V power supply
	B	M (0 V)	Electronics ground

The blanking covers for the DRIVE-CLiQ interfaces are included in the scope of delivery.

Blanking cover (50 pcs.) Article number: 6SL3066-4CA00-0AA0

4.6.3 Connection example

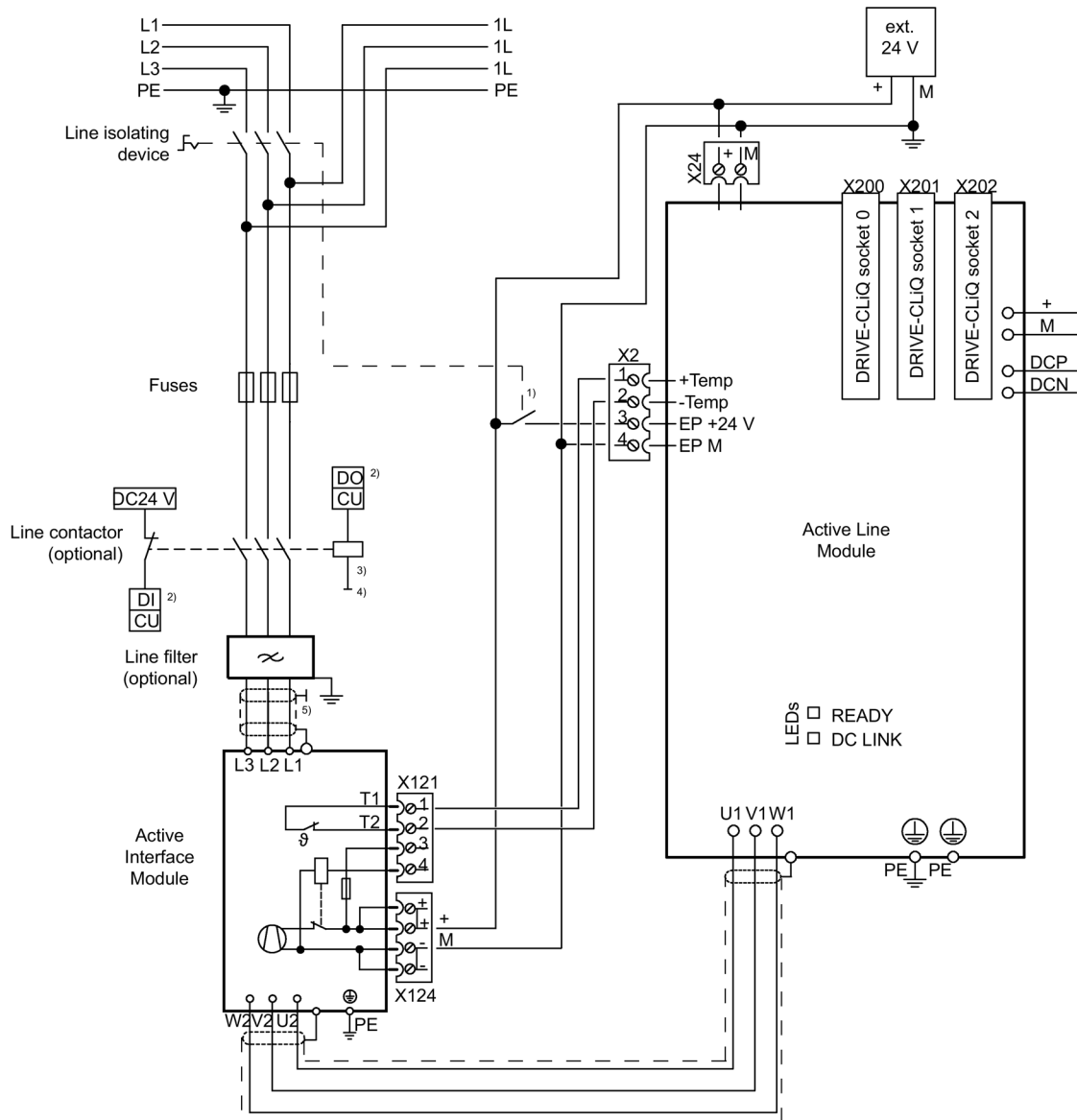

¹⁾ Leading opening contact $t > 10$ ms

²⁾ DI/DO, controlled by the Control Unit.

³⁾ No additional load permitted downstream of the line contactor!

⁴⁾ The current carrying capacity of the DO must be observed; an output coupling device may have to be used.

⁵⁾ Contact established through the rear mounting panel or shield rails in accordance with the EMC Directive.

Figure 4-35 Example connection of Active Line Module

Note

If you are using a VSM10 Voltage Sensing Module, the leading opening contact can be omitted.

4.6.4 Meaning of LEDs

Table 4- 38 Meaning of the LEDs on the Active Line Module

Status		Description, cause	Remedy
RDY	DC LINK		
off	off	The electronics power supply is missing or outside the permissible tolerance range.	–
Green	-- ¹⁾	The component is ready for operation. Cyclic DRIVE-CLiQ communication is established.	–
	Orange	The component is ready for operation. Cyclic DRIVE-CLiQ communication is established. The DC link voltage is present.	–
	Red	The component is ready for operation. Cyclic DRIVE-CLiQ communication is established. The DC link voltage is outside the permissible tolerance range.	Check the line supply voltage.
Orange	Orange	DRIVE-CLiQ communication is being established.	–
Red	-- ¹⁾	This component has at least one fault.	Resolve and acknowledge the fault.
Green/ red (0.5 Hz)	-- ¹⁾	Firmware is being downloaded.	–
Green/red (2 Hz)	-- ¹⁾	Firmware download has been completed. The system waits for POWER ON.	Carry out a POWER ON.
Green/orange or red/orange	-- ¹⁾	Component recognition via LED is activated ²⁾ . Note: Both options depend on the LED status when component recognition is activated.	–

¹⁾ Irrespective of the status of the LED "DC LINK"

²⁾ For information about activating the parameter "Recognition via LED", see SINAMICS S120/S150 List Manual

4.6.5 Dimension drawing

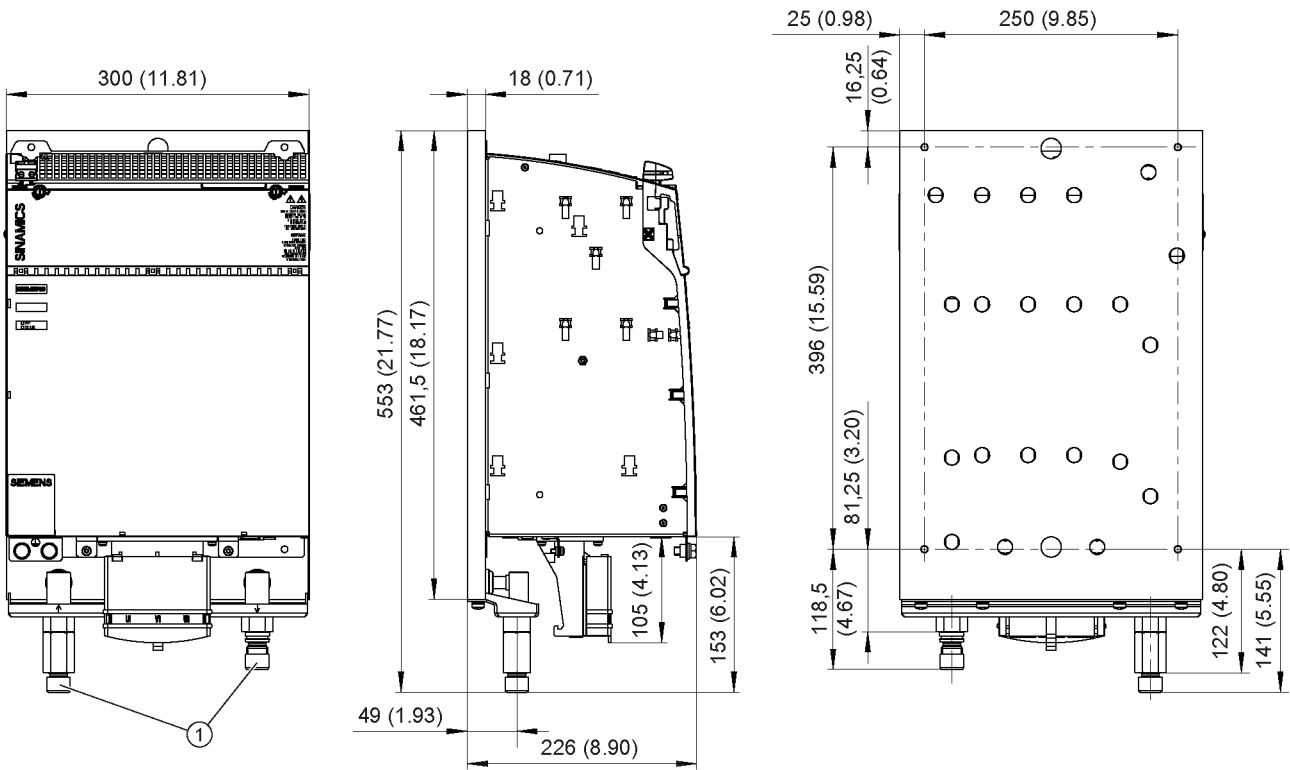

① Pipe thread ISO 228 G ½ B.

Figure 4-36 Dimension drawing of Active 120 kW Line Module Liquid Cooled, all dimensions in mm and (inches)

4.6.6 Installation

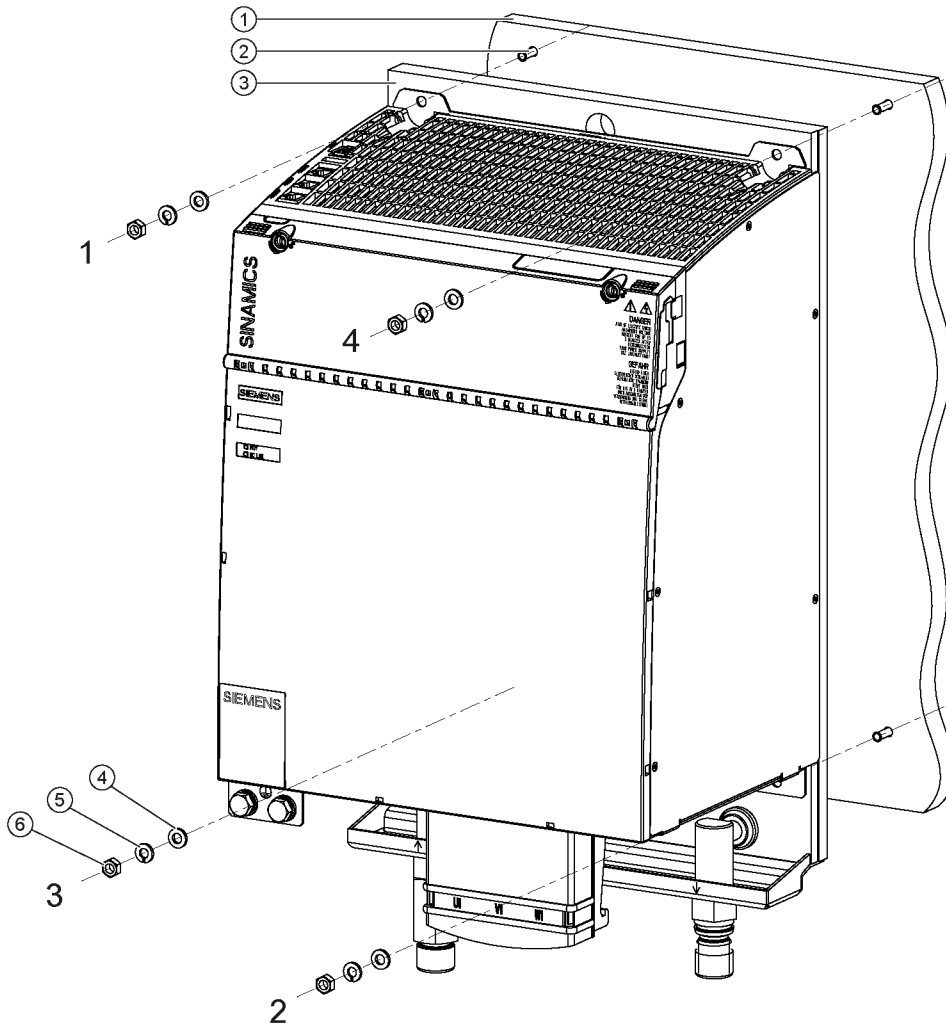

- ① Mounting surface
- ② Threaded bolts M6
- ③ Heat sink
- ④ Washer
- ⑤ Spring washer
- ⑥ M6 nut

Figure 4-37 Mounting an Active Line Module Liquid Cooled

Tightening torques:

1. Firstly, tighten the nuts by hand.
Tightening torque: 0.5 Nm (4.4 lbf in)
2. Then tighten the nuts in the specified sequence 1 to 4.
Tightening torque: 10 Nm (88.5 lbf in)

For installation, M6 threaded bolts and hexagon nuts/grub screws ISO 7436-M6x40-14 H, property class 8.8 are recommended.

The coolant connections are located on the lower side of the components. All connection elements can be accessed using an appropriate tool.

- Thread type of water connections: Pipe thread ISO 228 G ½ B.

4.6.7 Technical data

Table 4- 39 Technical data for an Active Line Module Liquid Cooled

Liquid Cooled		6SL3135-7TE31-2AA3
Rated power	kW	120
Infeed¹⁾		
Rated power S1 duty	kW (P _n)	120
Infeed power S6 duty (40 %)	kW (P _{S6})	145
Peak infeed power	kW (P _{max})	175
Regenerative feedback		
Continuous regenerative power	kW	120
Peak regenerative power	kW	175
Supply voltages		
Line voltage	V _{ACrms}	3 AC 380 ... 480 ±10 % (- 15 % < 1 min)
Line frequency	Hz	47 ... 63
Electronics power supply	V _{DC}	24 (20.4 ... 28.8)
DC-link voltage	V _{DC}	510 ... 720
Overvoltage trip	V _{DC}	820 ± 2 %
Undervoltage trip ²⁾	V _{DC}	360 ± 2 %
Input currents		
Rated input current: at AC 400 V	A _{AC}	182
Input current at AC 380 V / AC 480 V	A _{AC}	192 / 152
at AC 400 V; S6 duty (40%)	A _{AC}	220
at AC 400 V; peak current	A _{AC}	267
DC link currents		
Rated DC link current: at 600 V DC	A _{DC}	200
at 510 V DC / 720 V DC	A _{DC}	200 / 167
DC-link current: for 600 V DC; S6 duty (40 %)	A _{DC}	244
for 600 V DC; peak current	A _{DC}	292
Current carrying capacity		
DC link busbars	A _{DC}	200
24 V DC busbars	A _{DC}	20
Electronics current consumption at 24 V DC	A _{DC}	1.8
Total power loss (including electronics losses, see Power loss tables (Page 734))	W	2243.2

4.6 Active Line Modules Liquid Cooled

Liquid Cooled		6SL3135-7TE31-2AA3
Rated power	kW	120
DC link capacitance: Active Line Module Drive line-up, max.	μF μF	3995 20000
Power factor	$\cos \varphi$	1
Circuit breaker (IEC 60947 and UL)		See Chapter Overcurrent protection using fuses and circuit breakers (Page 47)
Max. total cable length ³⁾		See Chapter Combination options, Line Modules with line reactors and line filters (Page 120)
Rated flow rate for water at 70 kPa pressure drop (for other coolants, see Cooling circuit and coolant properties (Page 749))	l/min	8
Volume of liquid internal	ml	100
Max. coolant temperature without derating with derating	$^{\circ}\text{C}$ $^{\circ}\text{C}$	45 50
Max. permissible heat sink temperature	$^{\circ}\text{C}$	80
Ventilation clearances above/below	mm	≥ 80
Weight	kg	23

1) The specified power ratings apply to the line voltage range from 380 V to 480 V.

2) Default for 400 V line systems; undervoltage trip threshold is adjusted to the parameterized rated voltage

3) Maximum total cable length = Σ motor cables, line feeder cable from line filter to the Line Module

4.6.7.1 Characteristics

Rated duty cycles of Active Line Modules Liquid Cooled

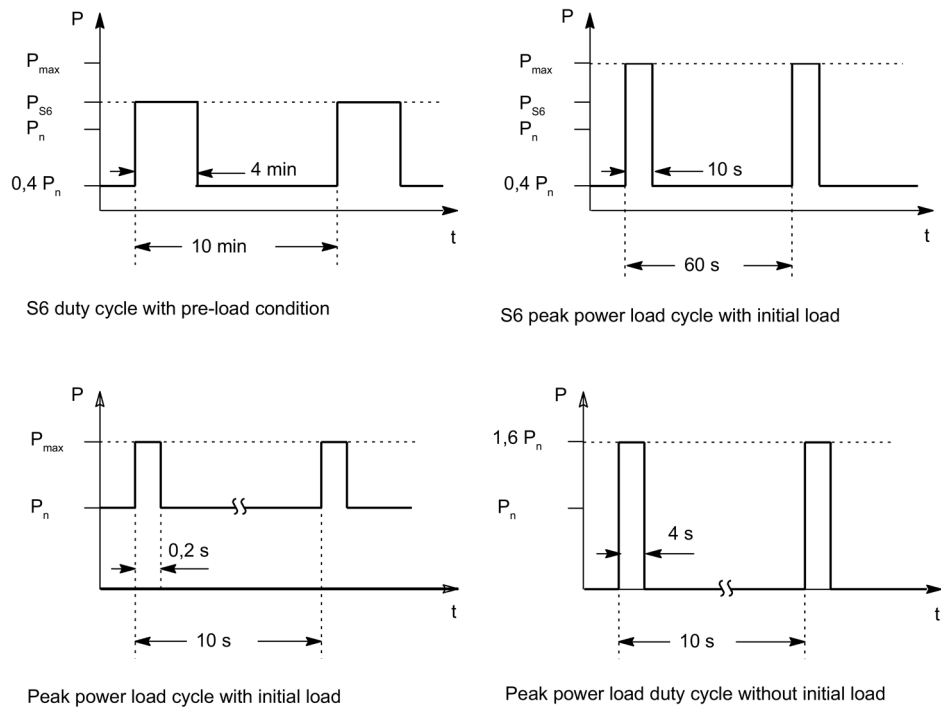

Figure 4-38 Rated duty cycles of Active Line Modules

Derating characteristics

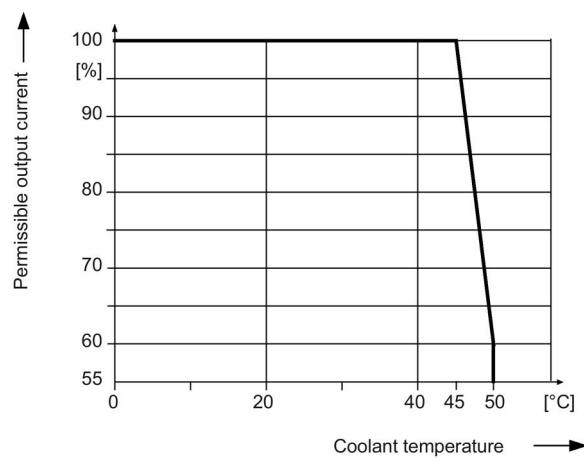

Figure 4-39 Output current as a function of the coolant temperature

Note

Information about derating the output current as a function of the ambient temperature and installation altitude is provided in Chapter "System data (Page 42)".

4.7 Basic Line Modules with internal air cooling

4.7.1 Description

The Basic Line Modules generate a non-regulated DC voltage, which matches the rectified line input voltage, from the 3-phase line voltage and feed this DC voltage into the DC link. One Basic Line Module can supply one or more Motor Modules with power via the DC link.

To reduce the energy, e.g. for emergency retraction, the 20 kW and 40 kW Basic Line Modules feature a control for an external braking resistor.

For 100 kW Basic Line Modules, an external braking unit is required for degradation of energy. Either Braking Modules Booksize Compact (also in a parallel connection) or a MASTERDRIVES braking unit (see Chapter "Braking units for 100 kW Basic Line Modules (Page 497)") can be used.

A line contactor can be installed on the line side if the system has to be electrically isolated from the line supply.

Basic Line Modules are suitable for direct operation on TN, IT and TT systems. The Line Modules have an integrated overvoltage protection function.

The 100 kW Basic Line Module features basic interference suppression, the 20 kW and 40 kW Basic Line Modules do not.

The ratio between the line short-circuit power (system fault level) and the rated power must be ≥ 30 .

Data regarding the radio interference voltage categories and maximum total cable lengths that can be achieved, see Chapter "Combination options, Line Modules with line reactors and line filters (Page 120)".

4.7.2 Interface description

4.7.2.1 Overview

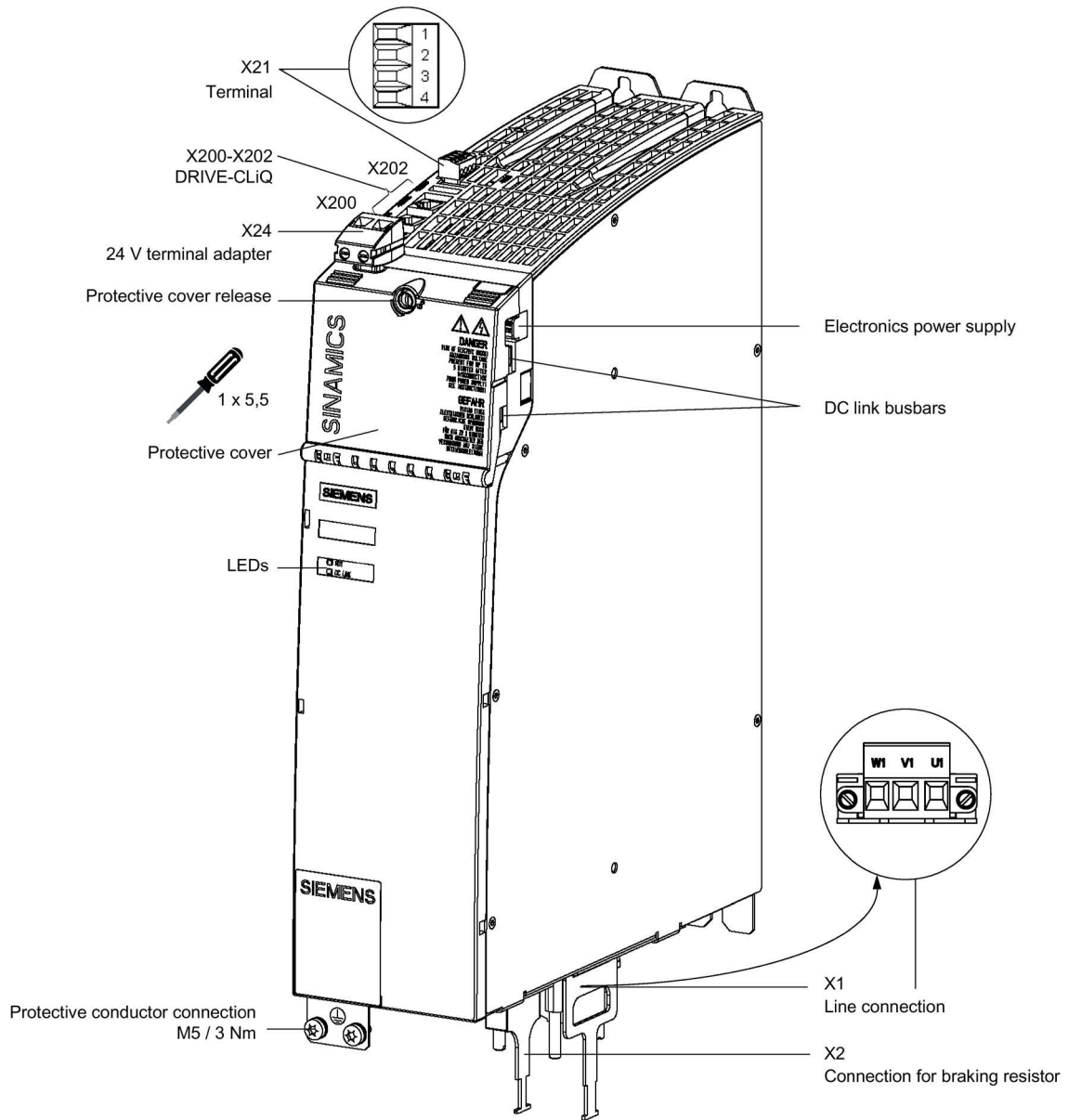

Figure 4-40 Interface overview, Basic Line Module with internal air cooling (example: 20 kW)

4.7 Basic Line Modules with internal air cooling

4.7.2.2 X1 line connection

Table 4- 40 X1: Line supply connection for Basic Line Modules 20 kW

	Terminal	Technical data
	U1	Supply voltage:
	V1	3 AC 380 ... 480 V, 50 / 60 Hz
	W1	Type: Screw terminal 7 (Page 708)
	Protective conductor connection	Threaded hole M5 / 3 Nm (26.6 lbf in) ¹⁾
¹⁾ For ring cable lugs without insulation (Page 710)		

Table 4- 41 X1: Line supply connection for Basic Line Modules 40 kW

	Terminal	Technical data
	U1	Supply voltage:
	V1	3 AC 380 ... 480 V, 50 / 60 Hz
	W1	Max. connectable cross section 50 mm ² (AWG 1), wire end ferrules Tightening torque min. 6 Nm (53.1 lbf in)
	Protective conductor connection	Threaded hole M6 / 6 Nm (53.1 lbf in) ¹⁾
¹⁾ For ring cable lugs without insulation (Page 710)		

Note

Compliance with IPXXB degree of protection for Basic Line Modules 40 kW

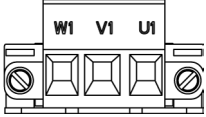
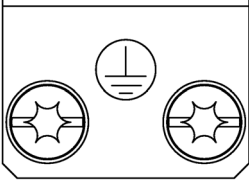
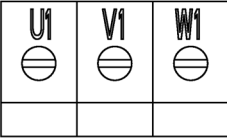
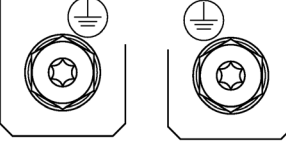
Degree of protection IPXXB according to EN 60529 for the Basic Line Module 40 kW is only obtained when power cables with insulated end sleeves and cross-sections > 25 mm² (AWG 4) are used.

Table 4- 42 X1: Line supply connection for Basic Line Modules 100 kW

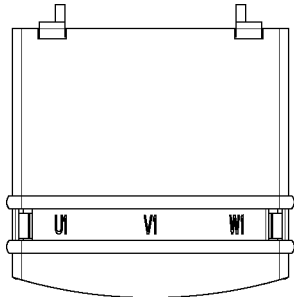
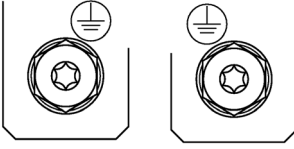
	Terminal	Technical data
	U1	Supply voltage: 3 AC 380 ... 480 V, 50 / 60 Hz Type: Threaded bolts M8 ¹⁾ Max. connectable cross-section: 120 mm ² (AWG 4/0) Tightening torque: 13 Nm (115 lbf in)
	V1	
	W1	
	Protective conductor connection	Threaded hole M6 / 6 Nm (53.1 lbf in) ¹⁾
¹⁾ For ring cable lugs without insulation (Page 710)		

4.7.2.3 X2 braking resistor connection

Table 4- 43 X2: Braking resistor connection at the Basic Line Module 20 kW

	Terminal	Designation	Technical data
	1	Braking resistor connection R1	Type: Screw terminal 4 (Page 708)
	2	Braking resistor connection R2	

Table 4- 44 X2: Braking resistor connection at the Basic Line Module 40 kW

	Terminal	Designation	Technical data
	1	Braking resistor connection R1	Type: Screw terminal 6 (Page 708)
	2	Braking resistor connection R2	

4.7 Basic Line Modules with internal air cooling

Table 4- 45 Braking resistors with a thermostatic switch for 20 kW and 40 kW Basic Line Modules

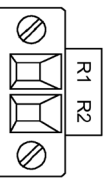
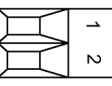
Braking resistor	R in Ω	P _N in kW	4 x P _N in kW	P _{max} in kW
6SE7018-0ES87-2DC0	80	1.25	5	7.5
6SE7021-6ES87-2DC0	40	2.5	10	15
6SE7023-2ES87-2DC0	20	5	20	30
6SE7028-0ES87-2DC0 ¹⁾	8	12.5	50	75

¹⁾ Not suitable for 20 kW Basic Line Module

For detailed technical information on the braking resistors, see the section entitled Braking resistors (Page 529).

4.7.2.4 X21 EP terminals

Table 4- 46 X21 EP terminal / temperature sensor

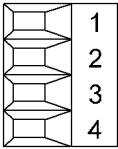
	Terminal	Designation	Technical data
	1	+ Temp	Temperature sensors ¹⁾ : KTY84-1C130 ²⁾ / PT1000 ²⁾ / PTC ²⁾ / bimetallic switch with NC contact With the 20 kW and 40 kW Basic Line Modules, the temperature sensor of the braking resistor (bimetallic switch with NC contact) is connected to the temperature input. Response thresholds of the temperature input: Temperature at the braking resistor in the operating range → resistance value ≤ 100 ohms Overtemperature at the braking resistor → resistance value > 100 ohms Fault responses: An alarm is output and the Basic Line Module is deactivated with a fault after one minute, if overtemperature is still present at the braking resistor. If there is no braking resistor, terminals 1 and 2 must be jumpered to deactivate the overtemperature.
	2	- Temp	
	3	EP +24 V (pulse enable)	Voltage: 24 V DC (20.4 ... 28.8 V)
	4	EP M (Enable Pulses)	Current consumption, typical: 4 mA at 24 V Isolated input
Type: Screw terminal 1 (Page 708)			

¹⁾ The temperature sensor type and the temperature output can be selected by parameter (see the SINAMICS S120/S150 List Manual).

²⁾ Temperatures are detected but not evaluated in the Basic Line Module.

Terminals X21.1 and X21.2**NOTICE****Overheating of the resistor if the temperature switch is not connected**

If the temperature switch is not connected, this can cause the overheating and thus damage to the resistor.

- Connect the temperature switch.

Terminals X21.3 and X21.4

For operation, the 24 V DC voltage must be connected to terminal X21.3 and ground to terminal X21.4.

Pulse cancellation is activated if the power supply is disconnected. As a consequence, regenerative feedback is deactivated and the bypass relay drops out. If the Line Module is not disconnected from the line supply when the EP terminal is de-energized, for example, because a line contactor is not installed, then the DC link remains charged.

**! WARNING****Electric shock in the event of voltage flashovers at the temperature sensor**

Voltage flashovers in the signal electronics can occur in motors without safe electrical separation of the temperature sensors.

- Use temperature sensors that comply with the specifications relating to protective separation.
- If safe electrical separation cannot be guaranteed (for linear motors or third-party motors, for example), use a Sensor Module External (SME120 or SME125) or Terminal Module TM120.

4.7.2.5 X24 24 V terminal adapter

Table 4- 47 X24: 24 V terminal adapter

	Terminal	Designation	Technical data
	+	24 V power supply	24 V DC supply voltage
	M	Ground	Electronics ground
Type: Screw terminal 5 (Page 708)			

The 24 V terminal adapter is included in the scope of supply.

4.7.2.6 X200-X202 DRIVE-CLiQ interfaces

Table 4- 48 X200-X202: DRIVE-CLiQ interfaces

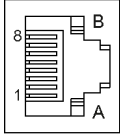
	PIN	Signal name	Technical data
	1	TXP	Transmit data +
	2	TXN	Transmit data -
	3	RXP	Receive data +
	4	Reserved, do not use	-
	5	Reserved, do not use	-
	6	RXN	Receive data -
	7	Reserved, do not use	-
	8	Reserved, do not use	-
	A	+(24 V)	24 V power supply
	B	M (0 V)	Electronics ground

The blanking covers for the DRIVE-CLiQ interfaces are included in the scope of delivery.

Blanking cover (50 pcs.) Article number: 6SL3066-4CA00-0AA0

4.7.3 Connection examples

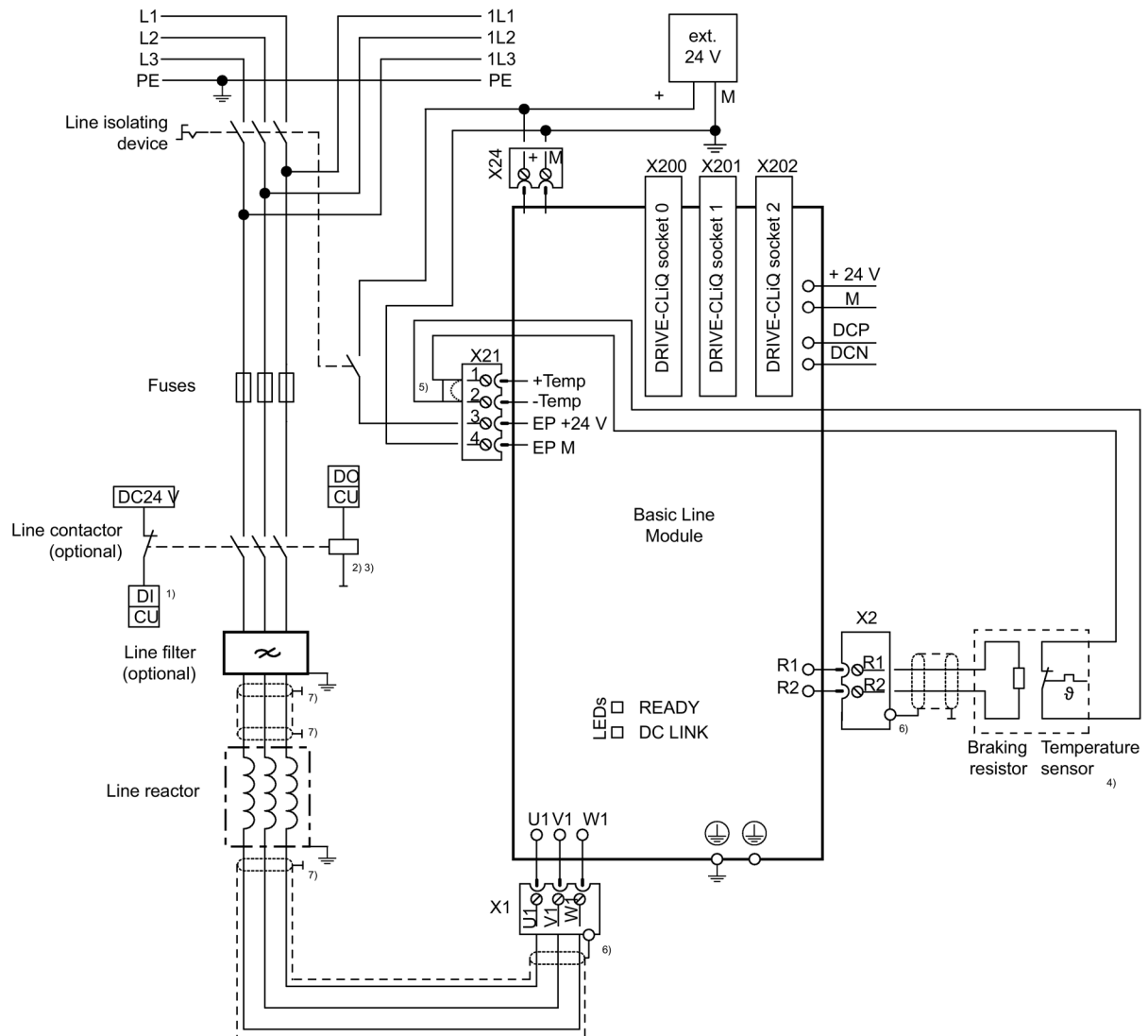

¹⁾DI/DO, controlled by the Control Unit

²⁾No additional load permitted downstream of the line contactor.

³⁾The current carrying capacity of the digital output (DO) must be observed; an output coupling device may have to be used.

⁴⁾The bimetallic switch with wiring may not exceed a resistance value of 100 ohm in the closed state.

⁵⁾Jumper for deactivating temperature monitoring for the braking resistor.

⁶⁾Contacting via plug connector (20 kW) or shield plate (40 kW).

⁷⁾Contact established via rear mounting panel or shielding buses in accordance with the EMC installation guideline.

Figure 4-41 Connection example: Basic Line Module (20 kW and 40 kW)

4.7 Basic Line Modules with internal air cooling

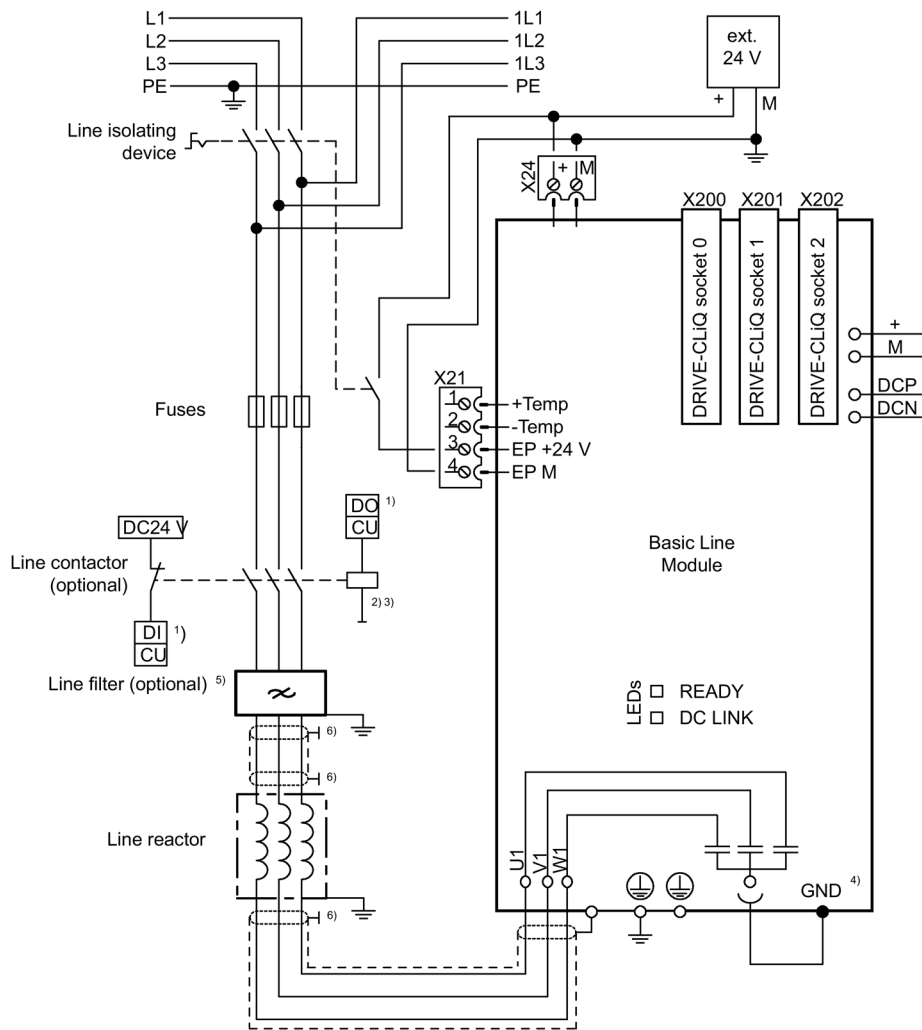

- ¹⁾DI/DO, controlled by the Control Unit
- ²⁾No additional load permitted downstream of the line contactor.
- ³⁾The current carrying capacity of the digital output (DO) must be observed; an output coupling device may have to be used.
- ⁴⁾The bimetallic switch with wiring may not exceed a resistance value of 100 ohm in the closed state.
- ⁵⁾Jumper for deactivating temperature monitoring for the braking resistor.
- ⁶⁾Contacting via plug connector (20 kW) or shield plate (40 kW).
- ⁷⁾Contact established via rear mounting panel or shielding buses in accordance with the EMC installation guideline.

Figure 4-42 Connection example: Basic Line Module (100 kW)

4.7.4 Meaning of LEDs

Table 4- 49 Meaning of the LEDs on the Basic Line Module

Status		Description, cause	Remedy
RDY	DC LINK		
Off	Off	The electronics power supply is missing or outside the permissible tolerance range.	–
Green	-- ¹⁾	The component is ready for operation. Cyclic DRIVE-CLiQ communication is taking place.	–
	Orange	The component is ready for operation. Cyclic DRIVE-CLiQ communication is taking place. The DC link voltage is present.	–
	Red	The component is ready for operation. Cyclic DRIVE-CLiQ communication is taking place. The DC link voltage is outside the permissible tolerance range.	Check the line supply voltage.
Orange	Orange	DRIVE-CLiQ communication is being established.	–
Red	-- ¹⁾	This component has at least one fault.	Resolve and acknowledge the fault.
Green/ red (0.5 Hz)	-- ¹⁾	Firmware is being downloaded.	–
Green/red (2 Hz)	-- ¹⁾	Firmware download has been completed. The system waits for POWER ON.	Carry out a POWER ON.
Green/orange or red/orange	-- ¹⁾	Component recognition via LED is activated ²⁾ . Note: Both options depend on the LED status when component recognition is activated.	–

1) Irrespective of the status of the LED "DC LINK"

2) For information about activating the parameter "Recognition via LED", see SINAMICS S120/S150 List Manual

4.7.5 Dimension drawings

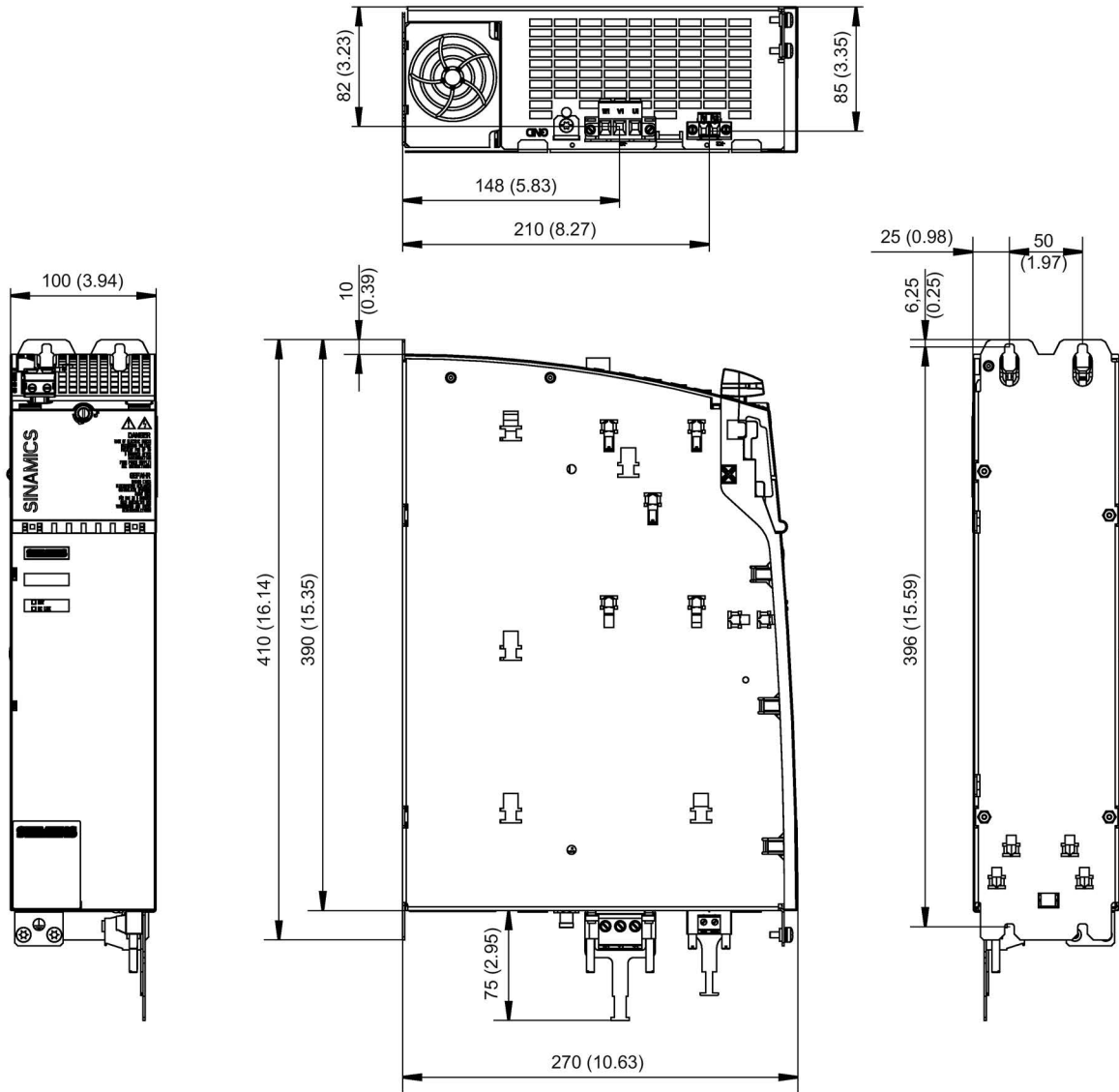

Figure 4-43 Dimension drawing of 20 kW Basic Line Module with internal air cooling, all dimensions in mm and (inches)

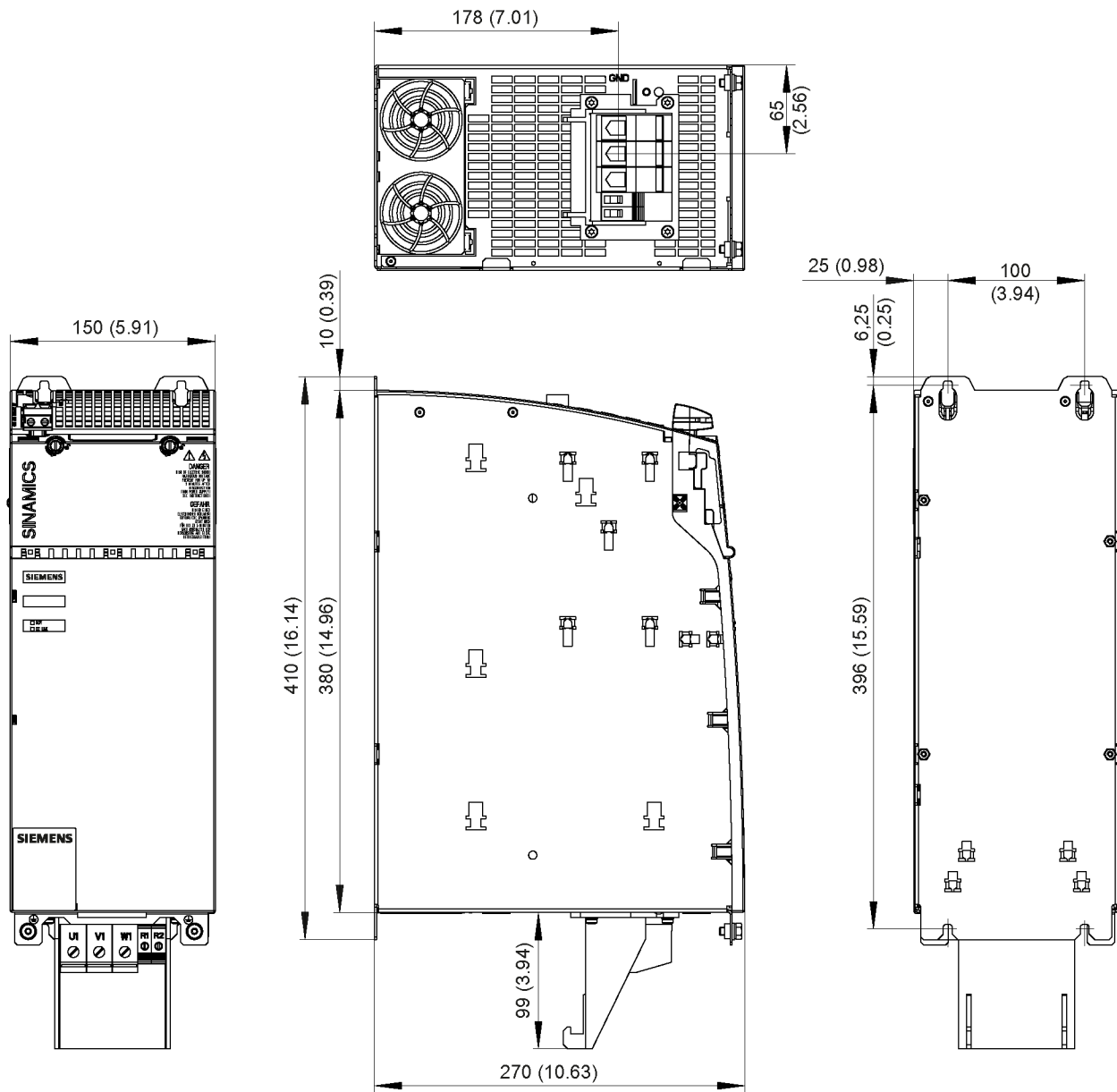

Figure 4-44 Dimension drawing of 40 kW Basic Line Module with internal air cooling, all dimensions in mm and (inches)

4.7 Basic Line Modules with internal air cooling

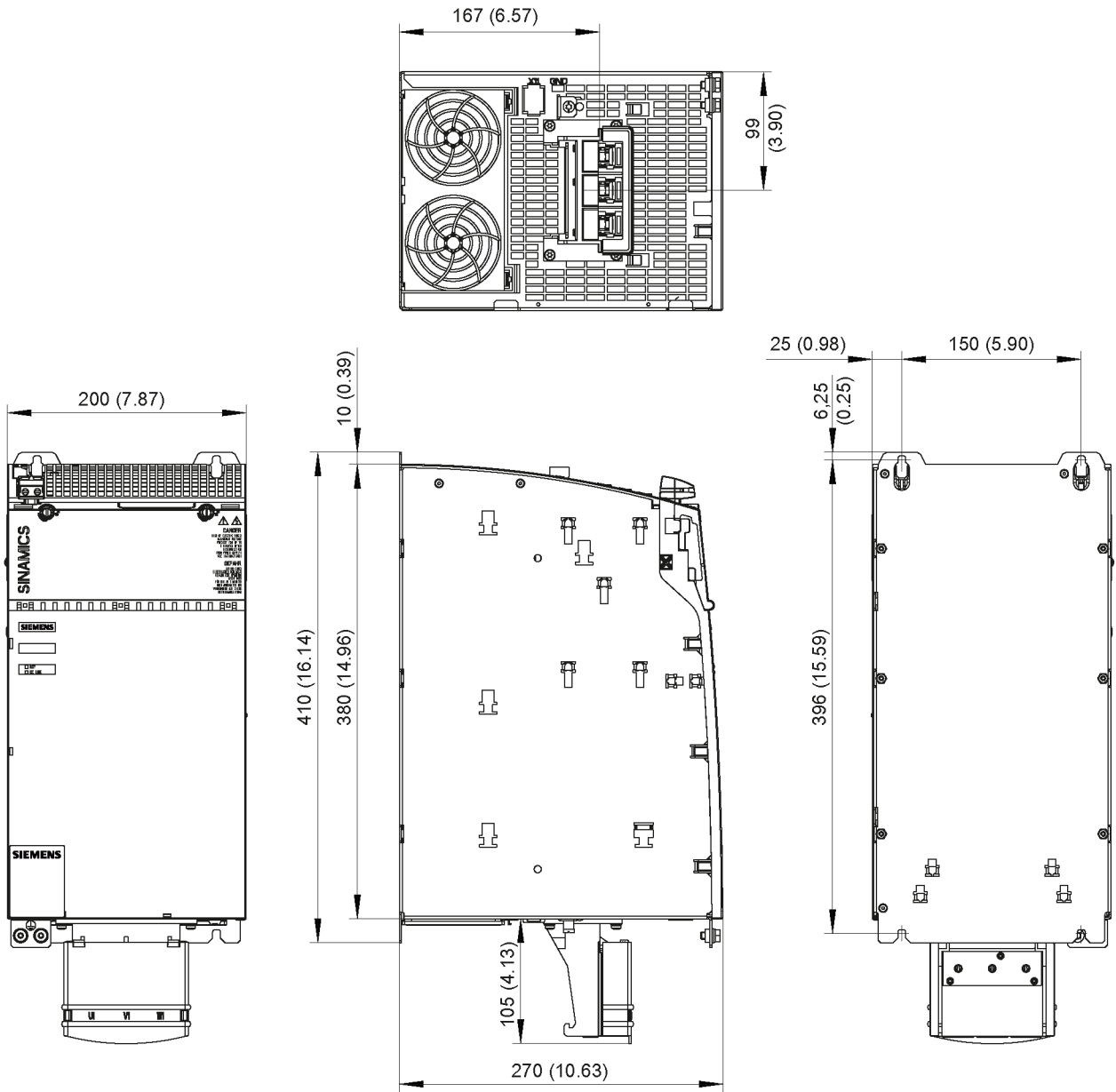
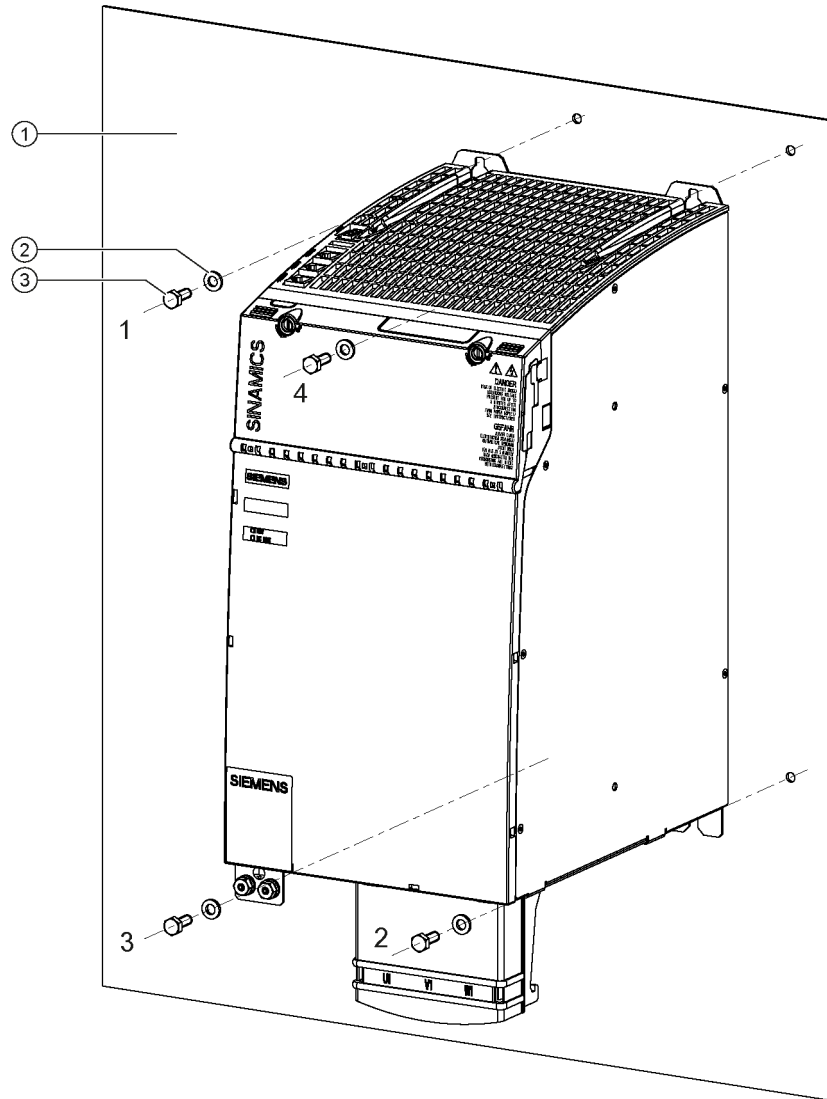

Figure 4-45 Dimension drawing of 100 kW Basic Line Module with internal air cooling, all dimensions in mm and (inches)

4.7.6 Installation

The Basic Line Modules are designed for installation in the control cabinet. They are fixed to the control cabinet panel or a mounting panel using M6 screws.



- ① Control cabinet panel/mounting panel
- ② Washer
- ③ M6 screw

Figure 4-46 Mounting a Basic Line Module with internal air cooling (example: 100 kW)

Tightening torques:

1. Firstly, tighten the nuts by hand.
Tightening torque: 0.5 Nm (4.4 lbf in)
2. Then tighten the nuts in the specified sequence.
Tightening torque: 6 Nm (53.1 lbf in)

4.7.7 Operation on an isolated-neutral system (IT system)

In IT systems, all live parts are isolated from ground, or one point is connected to ground through an impedance. Housings of loads in the electrical plant or system are either individually grounded, jointly grounded or are all connected to the system ground

To operate a 100 kW Basic Line Module on an isolated-neutral (IT) system, the connection bracket for the interference suppression capacitor (Page 221) must be removed. The connection bracket is located on the lower side of the component.

Note

Connection bracket to the interference suppression capacitor has not been removed

If the connection bracket for the interference suppression capacitor is not removed, an error message might be output via the insulation monitor in the system.

4.7.8 Operation on networks with asymmetrical grounding

TN or TT systems with asymmetrical grounding are not grounded at the neutral point, but rather at another reference point, for example at the line conductor.

For operation of a Basic Line Module 100 kW on such networks, the connection bracket for the interference suppression capacitor must be removed (see Chapter "Operation on an isolated network (IT system) (Page 220)".

The symmetrical filter branch and the clock frequency filter remain effective.

NOTICE
Damage to equipment if operation is carried out on asymmetrically grounded networks without the connecting bracket removed
With asymmetrical grounding, the interference suppression capacitors are subjected to voltage overload if the connection bracket has not been removed.
<ul style="list-style-type: none">• Remove the connection bracket for the interference suppression capacitor before commissioning.



4.7.9 Removing the connection clip for the interference suppression capacitor

 **WARNING**
Electric shock when the connection bracket is removed

Because of the capacitors, a hazardous voltage is present for up to 5 minutes after the power supply has been switched off.

Contact with live parts can result in death or serious injury.

- Wait 5 min. after the supply has been switched off before removing the connection bracket.

		
<p>1. Remove the connection bracket to the interference suppression capacitor using a Tx25 screwdriver.</p>	<p>2. Withdraw the connection bracket.</p>	<p>3. Connection bracket to the interference suppression capacitor</p>

Note**Installing the connection bracket for the interference-suppression capacitor**

For operation of the Basic Line Module in a TN or TT system with grounded neutral point, the connection bracket must be refitted and fastened with a tightening torque of 1.8 Nm (15.9 lbf in).

4.7.10 Technical data

Table 4- 50 Technical data: Basic Line Modules

Internal air cooling	6SL3130-	1TE22-0AA0	1TE24-0AA0	1TE31-0AA0
Rated power	kW	20	40	100
Infeed¹⁾				
Rated power S1 duty	kW (P_n)	20	40	100
Infeed power S6 duty (40 %)	kW (P_{S6})	26	52	130
Peak infeed power	kW (P_{max})	60	120	175
Braking power				
Continuous power	kW (P_n)	5	10	-
Peak power	kW (P_{max})	40	80	-
Supply voltages		3 AC 380 ... 480 $\pm 10\%$ (- 15 % < 1 min) ²⁾		
Line voltage	V_{ACrms}	47 ... 63		
Line frequency	Hz	24 (20.4 ... 28.8)		
Electronics power supply	V_{DC}	510 ... 720		
DC-link voltage	V_{DC}	820 $\pm 2\%$		
Overtoltage trip	V_{DC}	360 $\pm 2\%$		
Undervoltage trip ³⁾	V_{DC}			
Input currents				
Rated input current: for AC 400 V	A_{AC}	33	66	166
input current: for AC 380 V / AC 480 V	A_{AC}	35 / 28	70 / 55	172 / 138
for AC 400 V; S6 duty (40 %)	A_{AC}	43	86	216
for AC 400 V; peak current	A_{AC}	100	199	290
DC link currents				
Rated DC link current: at 600 V DC	A_{DC}	33.5	67	167
DC-link current: at 510 V DC / 720 V DC	A_{DC}	33.5 / 27.8	67 / 55.6	167 / 139
at 600 V DC; S6 duty (40%)	A_{DC}	43	87	217
at 600 V DC; peak current	A_{DC}	100	200	292
Current carrying capacity				
DC link busbars	A_{DC}	100	200	200
Reinforced DC link busbars	A_{DC}	150	--	--
24 V DC busbars	A_{DC}	20	20	20
Electronics current consumption at 24 V DC	A_{DC}	1	1.4	2.0
Total power loss (including electronics losses, see Power loss tables (Page 734))	W	144	283.6	628
DC link capacitance				
Basic Line Module	μF	940	1880	4100
Drive line-up, max.	μF	20000	20000	50000
Power factor⁴⁾	cos φ	0.98	0.98	0.98
Circuit breaker (IEC 60947 and UL)		See Chapter Overcurrent protection using fuses and circuit breakers (Page 47)		
Max. total cable length⁵⁾		See Chapter Combination options, Line Modules with line reactors and line filters (Page 120)		

Internal air cooling	6SL3130-	1TE22-0AA0	1TE24-0AA0	1TE31-0AA0
Sound pressure level	dB(A)	< 60	< 65	< 65
Cooling method (internal air cooling)		Internal fan		
Cooling air requirement	m ³ /h	56	112	180
Max. permissible heat sink temperature	°C	65	70	70
Ventilation clearances above/below	mm	≥ 80		
Rated voltage for rated data 3 AC 380 V				
Weight	kg	6.8	11.3	15.8

- 1) The specified power ratings apply to the line voltage range from 380 V to 480 V.
- 2) Can also be operated on supply systems with 200 ... 240 V 3 AC ±10 % with appropriate parameterization and reduced power.
- 3) Default for 400 V line systems; undervoltage trip threshold is adjusted to the parameterized rated voltage
- 4) Only the fundamental component
- 5) Maximum total cable length = Σ motor cables, line feeder cable from line filter to the Line Module

4.7.10.1 Characteristics

Rated duty cycles for Basic Line Modules

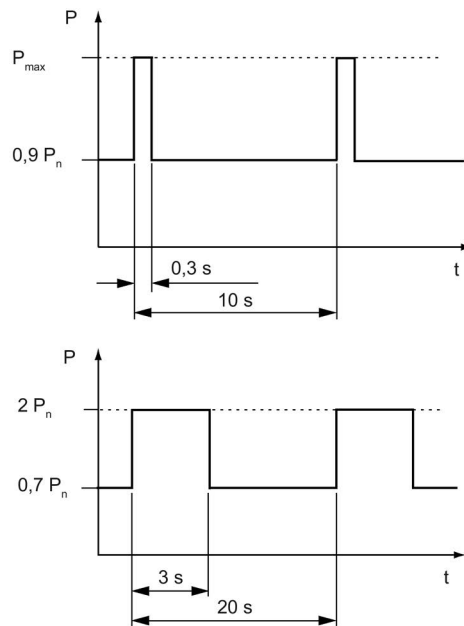

Figure 4-47 Duty cycles with initial load

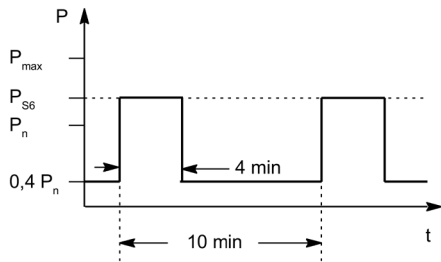

Figure 4-48 S6 duty cycle with pre-load condition

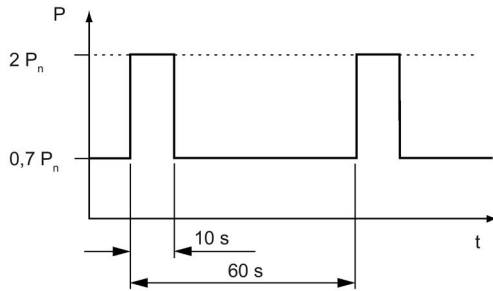

Figure 4-49 Duty cycle with pre-load condition for 20 kW and 40 kW Basic Line Modules

Braking duty cycle for Basic Line Modules

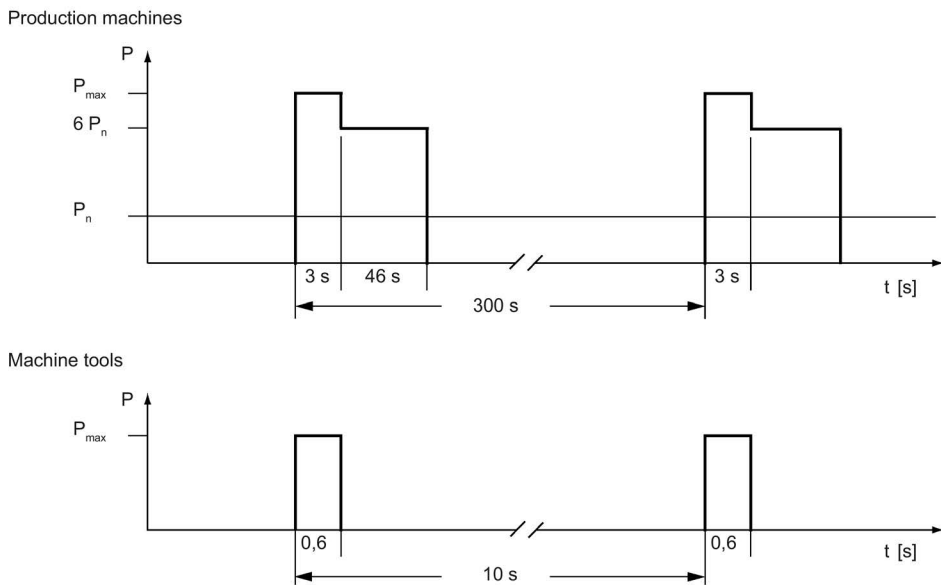

Figure 4-50 Braking duty cycle for Basic Line Modules

4.8 Basic Line Modules with cold plate

4.8.1 Description

The Basic Line Modules generate a non-regulated DC voltage, which matches the rectified line input voltage, from the 3-phase line voltage and feed this DC voltage into the DC link. One Basic Line Module can supply one or more Motor Modules with power via the DC link.

To reduce the energy, e.g. for emergency retraction, the 20 kW and 40 kW Basic Line Modules feature a control for an external braking resistor.

For 100 kW Basic Line Modules, an external braking unit is required for degradation of energy. Either Braking Modules Booksize Compact (also in a parallel connection) or a MASTERDRIVES braking unit (see Chapter "Braking units for 100 kW Basic Line Modules (Page 497)") can be used.

A line contactor can be installed on the line side if the system has to be electrically isolated from the line supply.

Basic Line Modules are suitable for direct operation on TN, IT and TT systems. The Line Modules have an integrated overvoltage protection function.

The 100 kW Basic Line Module features basic interference suppression, the 20 kW and 40 kW Basic Line Modules do not.

The ratio between the line short-circuit power (system fault level) and the rated power must be ≥ 30 .

Data regarding the radio interference voltage categories and maximum total cable lengths that can be achieved, see Chapter "Combination options, Line Modules with line reactors and line filters (Page 120)".

4.8.2 Interface description

4.8.2.1 Overview

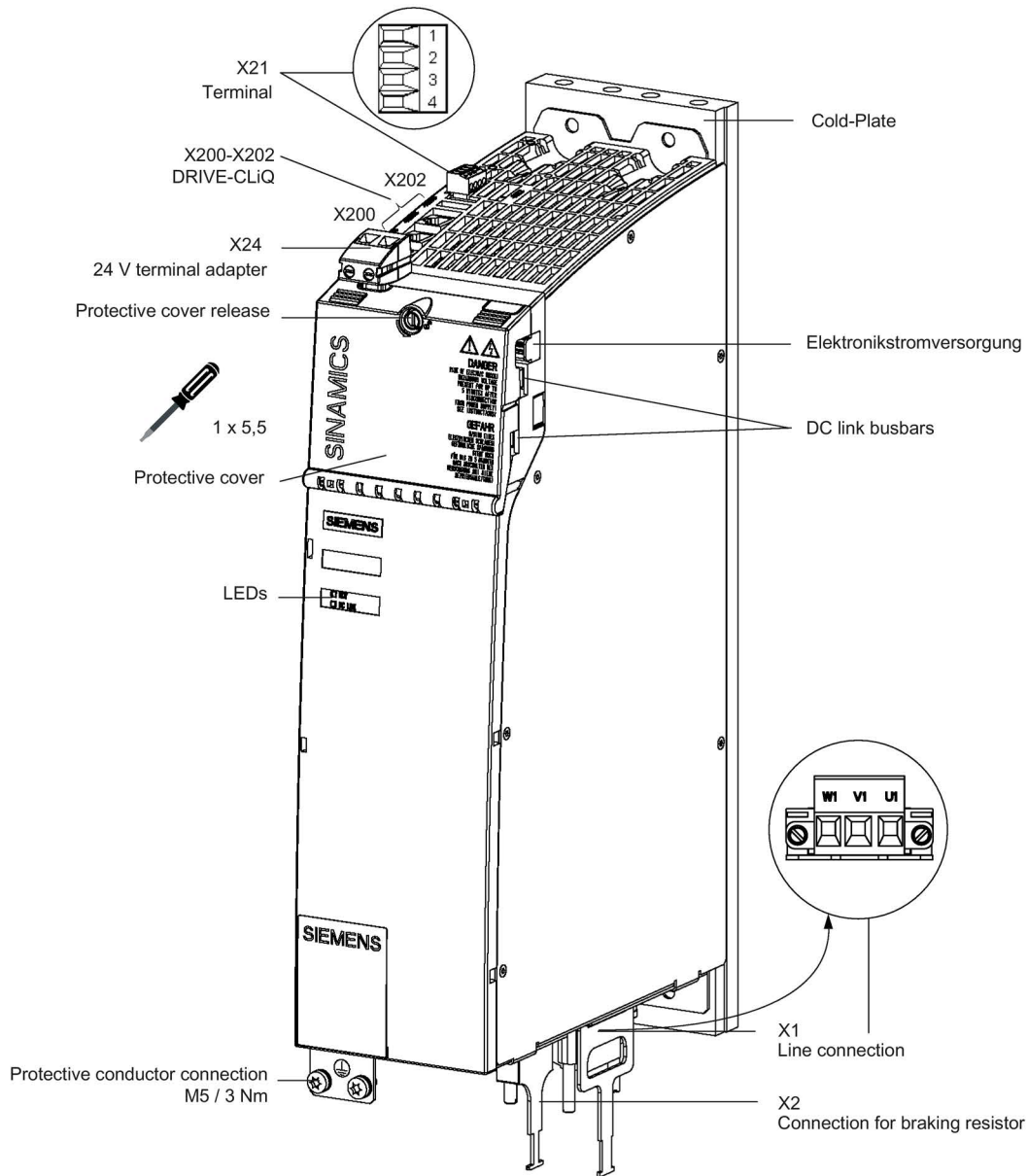

Figure 4-51 Interface overview, Basic Line Module with cold plate (example: 20 kW)

4.8.2.2 X1 line connection

Table 4- 51 X1: Line supply connection for Basic Line Modules 20 kW

	Terminal	Technical data
	U1	Supply voltage: 3 AC 380 ... 480 V, 50 / 60 Hz Type: Screw terminal 7 (Page 708)
	V1	
	W1	
	Protective conductor connection	Threaded hole M5 / 3 Nm (26.6 lbf in) ¹⁾
¹⁾ For ring cable lugs without insulation (Page 710)		

Table 4- 52 X1: Line supply connection for Basic Line Modules 40 kW

	Terminal	Technical data
	U1	Supply voltage: 3 AC 380 ... 480 V, 50 / 60 Hz Max. connectable cross section 50 mm ² (AWG 1), wire end ferrules Tightening torque min. 6 Nm (53.1 lbf in)
	V1	
	W1	
	Protective conductor connection	Threaded hole M6 / 6 Nm (53.1 lbf in) ¹⁾
¹⁾ For ring cable lugs without insulation (Page 710)		

Note

Compliance with IPXXB degree of protection for Basic Line Modules 40 kW

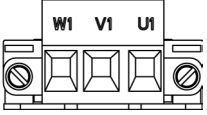
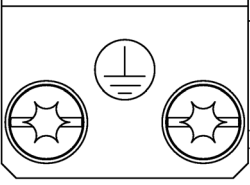
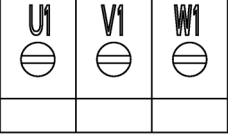
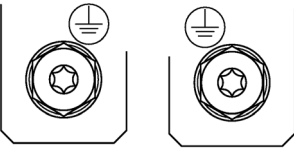
Degree of protection IPXXB according to EN 60529 for the Basic Line Module 40 kW is only obtained when power cables with insulated end sleeves and cross-sections > 25 mm² (AWG 4) are used.

4.8 Basic Line Modules with cold plate

Table 4- 53 X1: Line supply connection for Basic Line Modules 100 kW

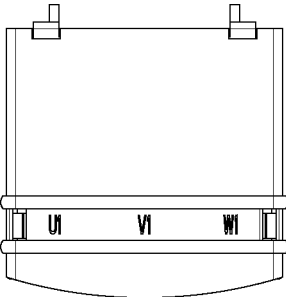
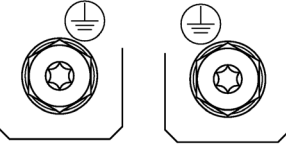
	Terminal	Technical data
	U1	Supply voltage: 3 AC 380 ... 480 V, 50 / 60 Hz Type: Threaded bolts M8 ¹⁾ Max. connectable cross-section: 120 mm ² (AWG 4/0) Tightening torque: 13 Nm (115 lbf in)
	V1	
	W1	
	Protective conductor connection	Threaded hole M6 / 6 Nm (53.1 lbf in) ¹⁾
¹⁾ For ring cable lugs without insulation (Page 710)		

4.8.2.3 X2 braking resistor connection

Table 4- 54 X2: Braking resistor connection at the Basic Line Module 20 kW

	Terminal	Designation	Technical data
	1	Braking resistor connection R1	Type: Screw terminal 4 (Page 708)
	2	Braking resistor connection R2	

Table 4- 55 X2: Braking resistor connection at the Basic Line Module 40 kW

	Terminal	Designation	Technical data
	1	Braking resistor connection R1	Type: Screw terminal 6 (Page 708)
	2	Braking resistor connection R2	

Table 4- 56 Braking resistors with a thermostatic switch for 20 kW and 40 kW Basic Line Modules

Braking resistor	R in Ω	P _N in kW	4 x P _N in kW	P _{max} in kW
6SE7018-0ES87-2DC0	80	1.25	5	7.5
6SE7021-6ES87-2DC0	40	2.5	10	15
6SE7023-2ES87-2DC0	20	5	20	30
6SE7028-0ES87-2DC0 ¹⁾	8	12.5	50	75

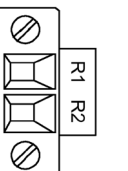
¹⁾ Not suitable for 20 kW Basic Line Module

For detailed technical information on the braking resistors, see the section entitled Braking resistors (Page 529).

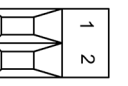
4.8.2.4 X21 EP terminals

Table 4- 57 X21 EP terminal / temperature sensor

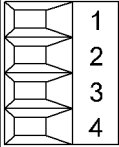
	Terminal	Designation	Technical data
	1	+ Temp	Temperature sensors ¹⁾ : KTY84-1C130 ²⁾ / PT1000 ²⁾ / PTC ²⁾ / bimetallic switch with NC contact With the 20 kW and 40 kW Basic Line Modules, the temperature sensor of the braking resistor (bimetallic switch with NC contact) is connected to the temperature input. Response thresholds of the temperature input: Temperature at the braking resistor in the operating range → resistance value ≤ 100 ohms Overtemperature at the braking resistor → resistance value > 100 ohms Fault responses: An alarm is output and the Basic Line Module is deactivated with a fault after one minute, if overtemperature is still present at the braking resistor. If there is no braking resistor, terminals 1 and 2 must be jumpered to deactivate the overtemperature.
	2	- Temp	
	3	EP +24 V (pulse enable)	Voltage: 24 V DC (20.4 ... 28.8 V)
	4	EP M (Enable Pulses)	Current consumption, typical: 4 mA at 24 V Isolated input
Type: Screw terminal 1 (Page 708)			

¹⁾ The temperature sensor type and the temperature output can be selected by parameter (see the SINAMICS S120/S150 List Manual).

²⁾ Temperatures are detected but not evaluated in the Basic Line Module.

Terminals X21.1 and X21.2

NOTICE
Overheating of the resistor if the temperature switch is not connected
If the temperature switch is not connected, this can cause the overheating and thus damage to the resistor.
<ul style="list-style-type: none"> • Connect the temperature switch.

Terminals X21.3 and X21.4

For operation, the 24 V DC voltage must be connected to terminal X21.3 and ground to terminal X21.4.

Pulse cancellation is activated if the power supply is disconnected. As a consequence, regenerative feedback is deactivated and the bypass relay drops out. If the Line Module is not disconnected from the line supply when the EP terminal is de-energized, for example, because a line contactor is not installed, then the DC link remains charged.



! WARNING
Electric shock in the event of voltage flashovers at the temperature sensor
Voltage flashovers in the signal electronics can occur in motors without safe electrical separation of the temperature sensors.
<ul style="list-style-type: none"> • Use temperature sensors that comply with the specifications relating to protective separation. • If safe electrical separation cannot be guaranteed (for linear motors or third-party motors, for example), use a Sensor Module External (SME120 or SME125) or Terminal Module TM120.

4.8.2.5 X24 24 V terminal adapter

Table 4- 58 X24: 24 V terminal adapter

	Terminal	Designation	Technical data
	+	24 V power supply	24 V DC supply voltage
	M	Ground	Electronics ground
Type: Screw terminal 5 (Page 708)			

The 24 V terminal adapter is included in the scope of supply.

4.8.2.6 X200-X202 DRIVE-CLiQ interfaces

Table 4- 59 X200-X202: DRIVE-CLiQ interfaces

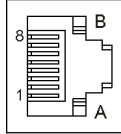
	PIN	Signal name	Technical data
	1	TXP	Transmit data +
	2	TXN	Transmit data -
	3	RXP	Receive data +
	4	Reserved, do not use	-
	5	Reserved, do not use	-
	6	RXN	Receive data -
	7	Reserved, do not use	-
	8	Reserved, do not use	-
	A	+(24 V)	24 V power supply
	B	M (0 V)	Electronics ground

The blanking covers for the DRIVE-CLiQ interfaces are included in the scope of delivery.

Blanking cover (50 pcs.) Article number: 6SL3066-4CA00-0AA0

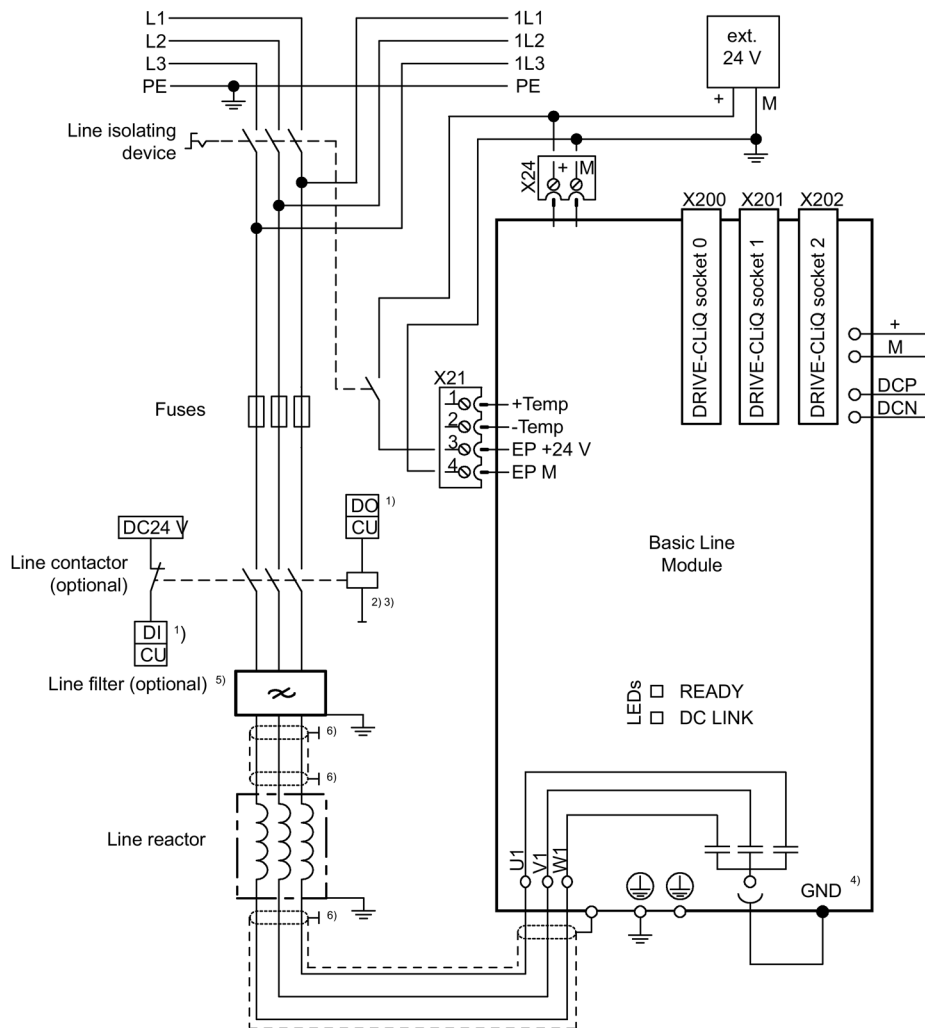

¹⁾DI/DO, controlled by the Control Unit

²⁾No additional load permitted downstream of the line contactor.

³⁾The current carrying capacity of the digital output (DO) must be observed; an output coupling device may have to be used.

⁴⁾The bimetallic switch with wiring may not exceed a resistance value of 100 ohm in the closed state.

⁵⁾Jumper for deactivating temperature monitoring for the braking resistor.

⁶⁾Contacting via plug connector (20 kW) or shield plate (40 kW).

⁷⁾Contact established via rear mounting panel or shielding buses in accordance with the EMC installation guideline.

Figure 4-53 Connection example: Basic Line Module (100 kW)

4.8.4 Meaning of LEDs

Table 4- 60 Meaning of the LEDs on the Basic Line Module

Status		Description, cause	Remedy
RDY	DC LINK		
Off	Off	The electronics power supply is missing or outside the permissible tolerance range.	–
Green	-- ¹⁾	The component is ready for operation. Cyclic DRIVE-CLiQ communication is taking place.	–
	Orange	The component is ready for operation. Cyclic DRIVE-CLiQ communication is taking place. The DC link voltage is present.	–
	Red	The component is ready for operation. Cyclic DRIVE-CLiQ communication is taking place. The DC link voltage is outside the permissible tolerance range.	Check the line supply voltage.
Orange	Orange	DRIVE-CLiQ communication is being established.	–
Red	-- ¹⁾	This component has at least one fault.	Resolve and acknowledge the fault.
Green/ red (0.5 Hz)	-- ¹⁾	Firmware is being downloaded.	–
Green/red (2 Hz)	-- ¹⁾	Firmware download has been completed. The system waits for POWER ON.	Carry out a POWER ON.
Green/orange or red/orange	-- ¹⁾	Component recognition via LED is activated ²⁾ . Note: Both options depend on the LED status when component recognition is activated.	–

¹⁾ Irrespective of the status of the LED "DC LINK"

²⁾ For information about activating the parameter "Recognition via LED", see SINAMICS S120/S150 List Manual

4.8.5 Dimension drawings

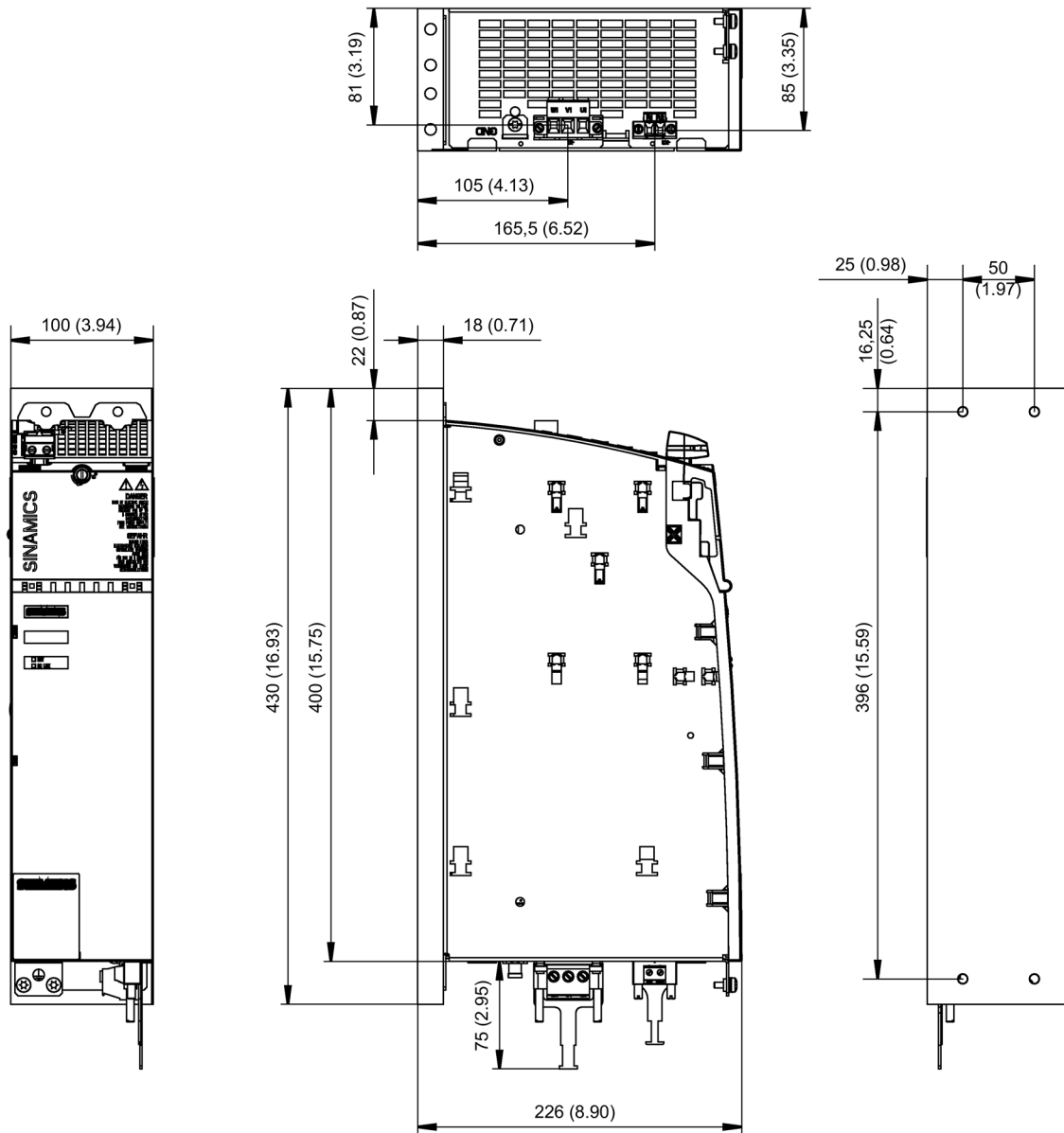

Figure 4-54 Dimension drawing of 20 kW Basic Line Module with cold plate, all dimensions in mm and (inches)

4.8 Basic Line Modules with cold plate

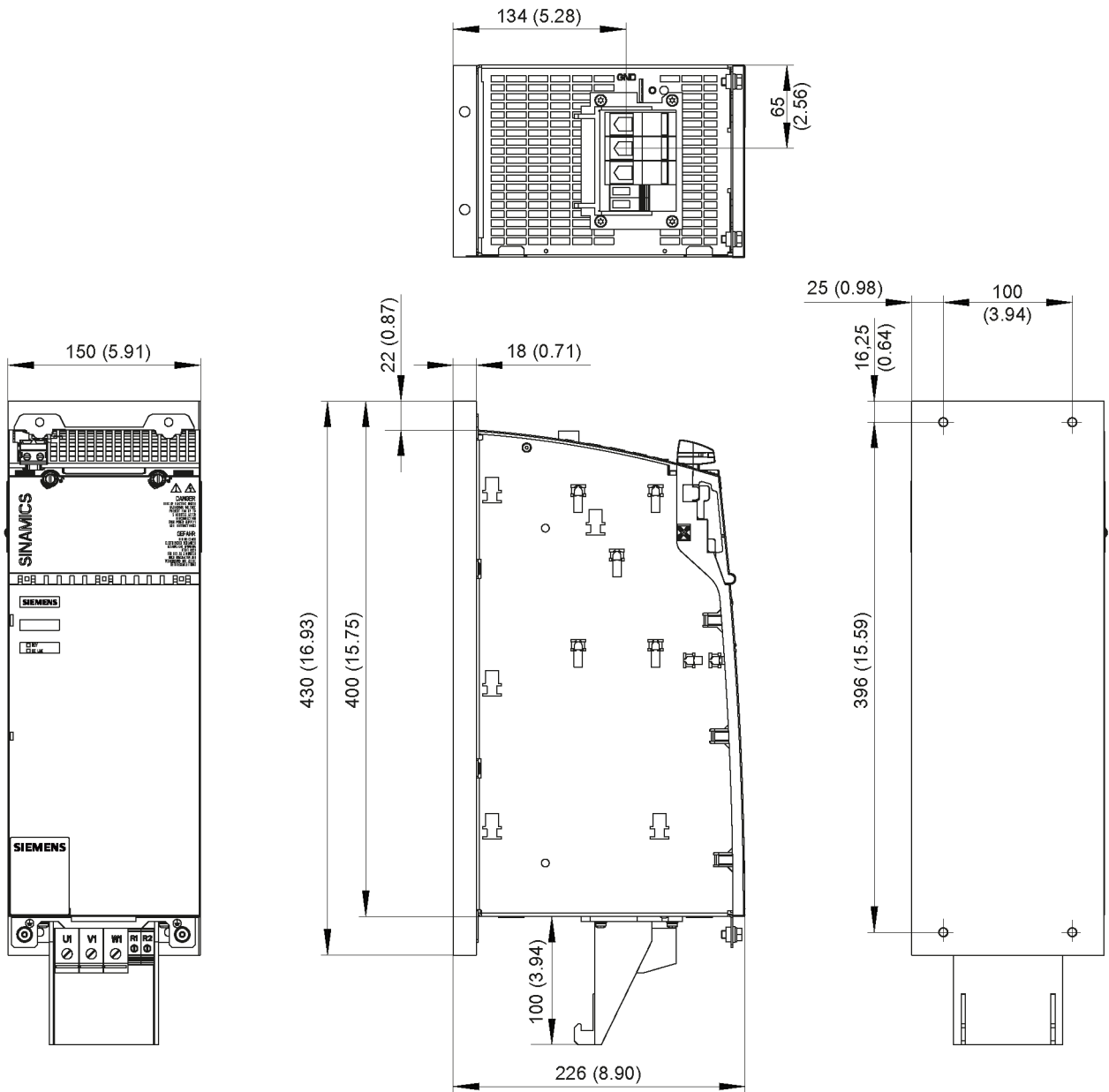

Figure 4-55 Dimension drawing of 40 kW Basic Line Module with cold plate, all dimensions in mm and (inches)

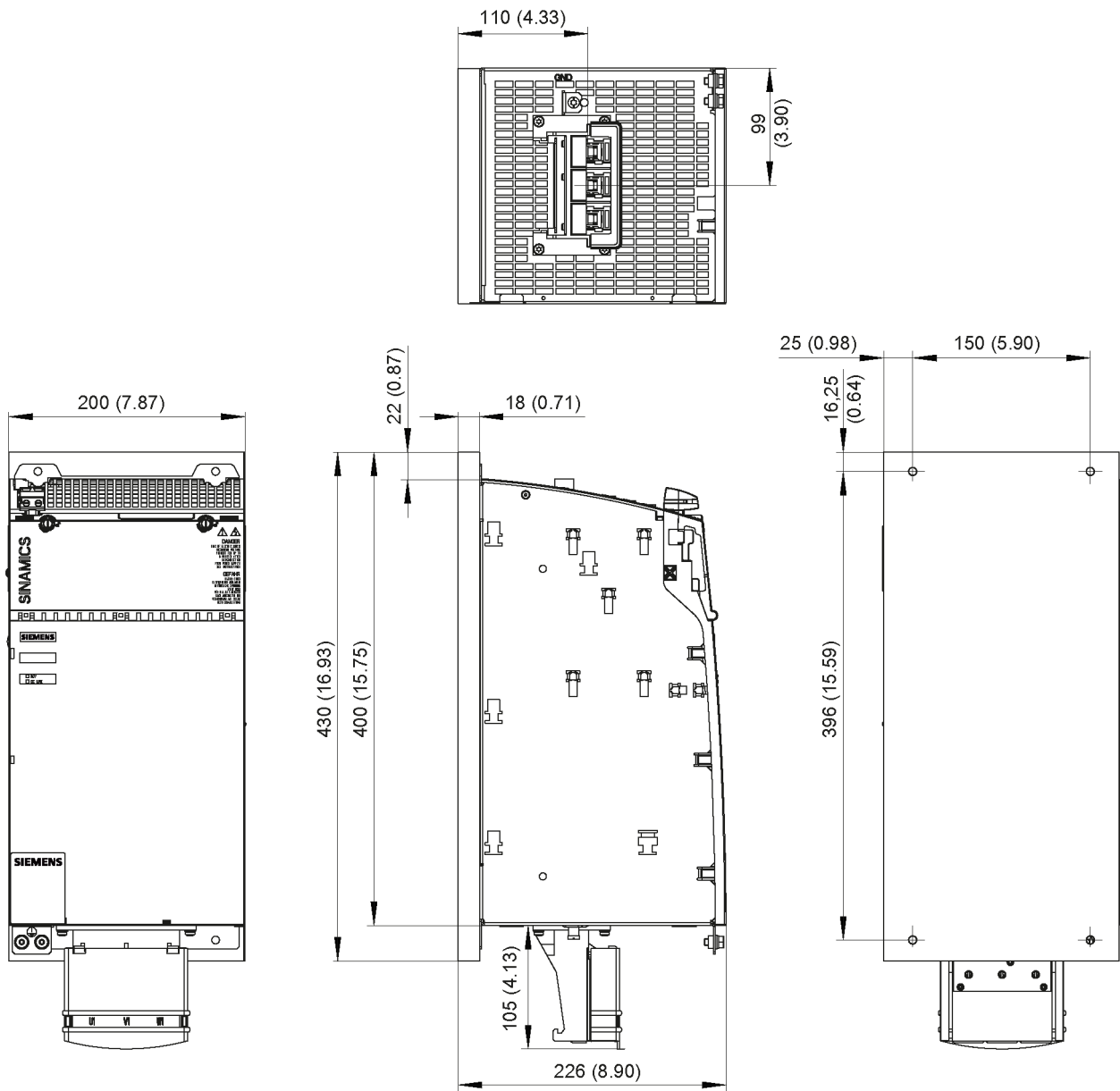

Figure 4-56 Dimension drawing of 100 kW Basic Line Module with cold plate, all dimensions in mm and (inches)

4.8.6 Mounting

Please note the following before mounting a Basic Line Module with cold plate onto a customer-specific heat sink:

- Before mounting, check the surface of the heat sink to ensure that it is not damaged.
- To improve heat transfer, a heat-conducting medium must be used. Special spherical-indented heat-conducting foil must be used for this purpose. Every Basic Line Module cold plate is supplied with heat-conducting foil cut to the right size. Note the mounting position of the heat-conducting foil (see figures below).

Note

- Also replace the heat-conducting foil when replacing a component.
 - Only use heat-conducting foil released or supplied by Siemens.
-

Table 4- 61 Overview of heat-conducting foils

	Article No.
Heat-conducting foil, 100 mm	6SL3162-6FD00-0AA0
Heat-conducting foil, 150 mm	6SL3162-6FF00-0AA0
Heat-conducting foil, 200 mm	6SL3162-6FH00-0AA0

Note

To mount the components, M6 threaded bolts and hexagon nuts/grub screws ISO 7436-M6x40-14 H, property class 8.8 are recommended.

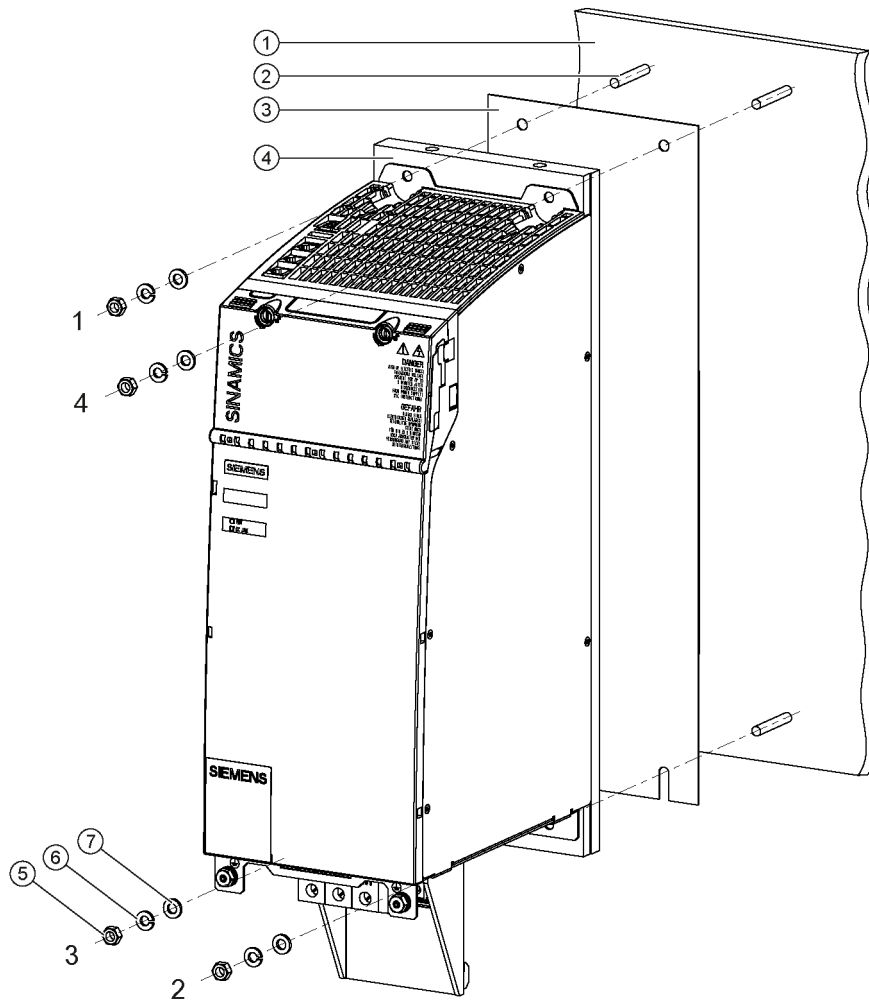

- ① External heat sink
- ② Threaded bolts M6
- ③ Heat-conducting foil
- ④ Cold plate
- ⑤ M6 nut
- ⑥ Spring washer
- ⑦ Washer

Figure 4-57 Mounting a Basic Line Module 40 kW with cold plate on an external heat sink

Tightening torques:

1. Firstly, tighten the nuts by hand.
Tightening torque: 0.5 Nm (4.4 lbf in)
2. Then tighten the nuts in the specified sequence 1 to 4.
Tightening torque: 10 Nm (88.5 lbf in)

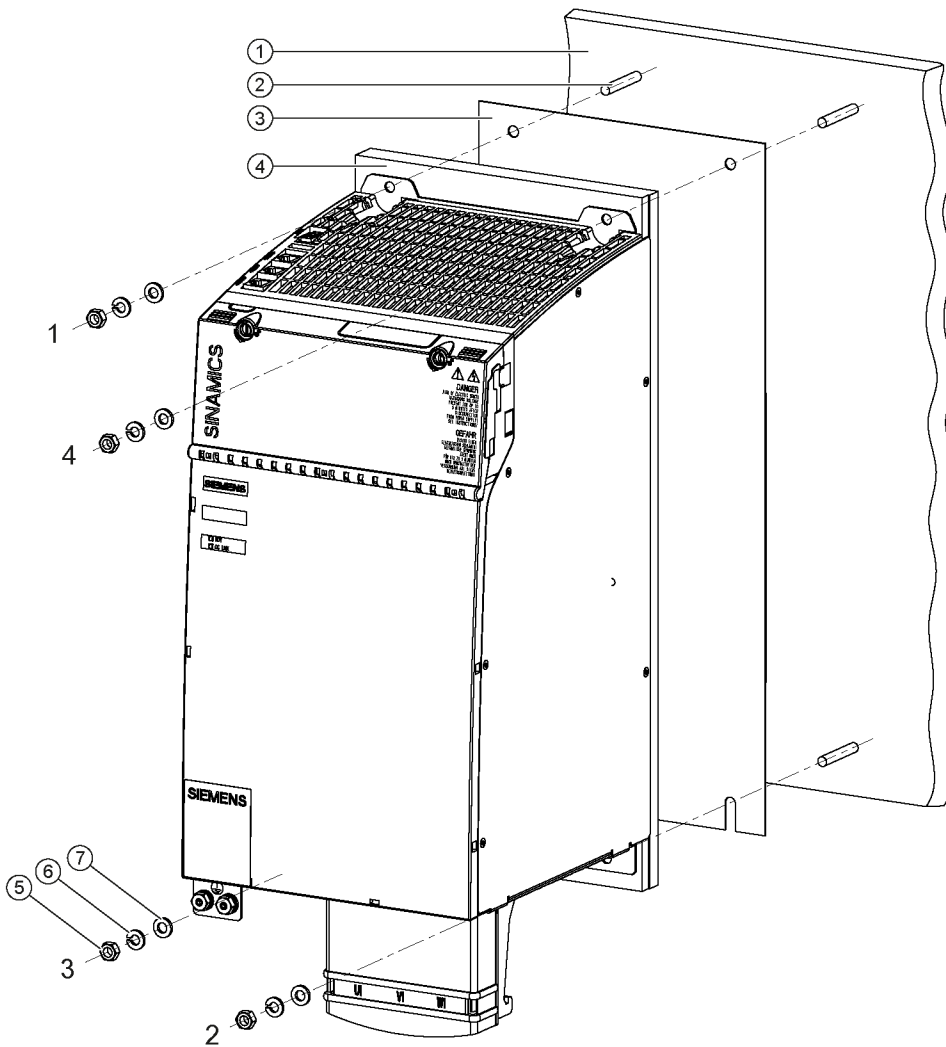

- ① External heat sink
- ② Threaded bolts M6
- ③ Heat-conducting foil
- ④ Cold plate
- ⑤ M6 nut
- ⑥ Spring washer
- ⑦ Washer

Figure 4-58 Mounting a Basic Line Module 100 kW with cold plate on an external heat sink

Tightening torques:

1. Firstly, tighten the nuts by hand.
Tightening torque: 0.5 Nm (4.4 lbf in)
2. Then tighten the nuts in the specified sequence 1 to 4.
Tightening torque: 10 Nm (88.5 lbf in)

Support with the mechanical control cabinet design is available from:

Siemens AG
 Digital Factory, DF MC MF - WKC AS
 TCCCC (Technical Competence Center Cabinets Chemnitz)
 Postfach 1124
 09070 Chemnitz
 E-mail: cc.cabinetcooling.aud@siemens.com

Properties of the heat sink

AlMgSi 0.5 is recommended as the heat sink material.
 The roughness of the external heat sink surface should be at least Rz 16 and the contact surface between the heat sink and cold plate should have an evenness of 0.2 mm (applicable to a height of 450 mm and width of 300 mm).

Note

Machine manufacturers can adapt the heat sink version to their special requirements. The specified rated data for the Power Modules can only be achieved if the power losses can be dissipated by the external heat sink under the specified general conditions.

NOTICE**Damage to the cold plate caused by incorrect mounting**

The threaded bolts can damage the cold plate when it is being mounted.

- Do not damage the cold plate.

4.8.7 Operation on an isolated-neutral system (IT system)

In IT systems, all live parts are isolated from ground, or one point is connected to ground through an impedance. Housings of loads in the electrical plant or system are either individually grounded, jointly grounded or are all connected to the system ground

To operate a 100 kW Basic Line Module on an isolated-neutral (IT) system, the connection bracket for the interference suppression capacitor (Page 242) must be removed. The connection bracket is located on the lower side of the component.

Note**Connection bracket to the interference suppression capacitor has not been removed**

If the connection bracket for the interference suppression capacitor is not removed, an error message might be output via the insulation monitor in the system.

4.8.8 Operation on networks with asymmetrical grounding

TN or TT systems with asymmetrical grounding are not grounded at the neutral point, but rather at another reference point, for example at the line conductor.

For operation of a Basic Line Module 100 kW on such networks, the connection bracket for the interference suppression capacitor must be removed (see Chapter "Operation on an isolated network (IT system) (Page 241)".

The symmetrical filter branch and the clock frequency filter remain effective.

NOTICE

Damage to equipment if operation is carried out on asymmetrically grounded networks without the connecting bracket removed

With asymmetrical grounding, the interference suppression capacitors are subjected to voltage overload if the connection bracket has not been removed.

- Remove the connection bracket for the interference suppression capacitor before commissioning.

4.8.9 Removing the connection clip for the interference suppression capacitor





! WARNING

Electric shock when the connection bracket is removed

Because of the capacitors, a hazardous voltage is present for up to 5 minutes after the power supply has been switched off.

Contact with live parts can result in death or serious injury.

- Wait 5 min. after the supply has been switched off before removing the connection bracket.

		
1. Remove the connection bracket to the interference suppression capacitor using a Tx25 screwdriver.	2. Withdraw the connection bracket.	3. Connection bracket to the interference suppression capacitor

Note**Installing the connection bracket for the interference-suppression capacitor**

For operation of the Basic Line Module in a TN or TT system with grounded neutral point, the connection bracket must be refitted and fastened with a tightening torque of 1.8 Nm (15.9 lbf in).

4.8.10 Technical data

Table 4- 62 Technical data for Basic Line Modules with cold plate cooling

	6SL3136-	1TE22-0AA0	1TE24-0AA0	1TE31-0AA0
Rated power	kW	20	40	100
Infeed¹⁾				
Rated power S1 duty	kW (P_n)	20	40	100
Infeed power S6 duty (40 %)	kW (P_{S6})	26	52	130
Peak infeed power	kW (P_{max})	60	120	175
Braking power				
Continuous power	kW (P_n)	5	10	-
Peak power	kW (P_{max})	40	80	-
Supply voltages		3 AC 380 ... 480 \pm 10 % (-15 % < 1 min)		
Line voltage	V_{ACrms}	47 ... 63		
Line frequency	Hz	24 (20.4 ... 28.8)		
Electronics power supply	V_{DC}	510 ... 720		
DC-link voltage	V_{DC}	820 \pm 2 %		
Overvoltage trip	V_{DC}	360 \pm 2 %		
Undervoltage trip ²⁾	V_{DC}			

4.8 Basic Line Modules with cold plate

	6SL3136-	1TE22-0AA0	1TE24-0AA0	1TE31-0AA0
Rated input currents at AC 380 V at AC 480 V / AC 528 V at 480 V; S6 duty (40 %)	A _{AC} A _{AC} A _{AC}	34.5 31 / 29 38	69 62 / 58 78	172 154 / 145 193
Peak current at AC 400 V / AC 480 V)	A _{AC}	113 / 91	208 / 172	265 / 252
DC link currents Rated DC link current: at 600 V DC DC-link current: at 510 V DC / 720 V DC at 600 V DC; S6 duty (40%) at 600 V DC; peak current	A _{DC} A _{DC} A _{DC} A _{DC}	33.5 33.5 / 27.8 43 100	67 67 / 55.6 87 200	167 167 / 139 217 292
Current carrying capacity DC link busbars Reinforced DC link busbars 24 V DC busbars	A _{ACrms} A _{ACrms} A _{ACrms}	100 150 20	200 -- 20	200 -- 20
Electronics current consumption at 24 V DC	A _{DC}	0.9	1.1	1.6
Total power loss (including electronics losses, see Power loss tables (Page 734))	W	141.6	276.4	618.4
DC link capacitance Basic Line Module Drive line-up, max.	μF μF	940 20000	1880 20000	4100 20000
Power factor ³⁾	cos φ	approx. 0.98		
Circuit breaker (IEC 60947 and UL)		See Chapter Overcurrent protection using fuses and circuit breakers (Page 47)		
Max. total cable length ⁴⁾		See Chapter Combination options, Line Modules with line reactors and line filters (Page 120)		
Max. permissible heat sink temperature	°C	70	70	70
Ventilation clearances above/below	mm	≥ 80		
Weight	kg	6.4	10.9	16.4

1) The specified power ratings apply to the line voltage range from 380 V to 480 V.

2) Default for 400 V line systems; undervoltage trip threshold is adjusted to the parameterized rated voltage

3) Only the fundamental component

4) Maximum total cable length = Σ motor cables, line feeder cable from line filter to the Line Module

4.8.10.1 Characteristics

Rated duty cycles for Basic Line Modules

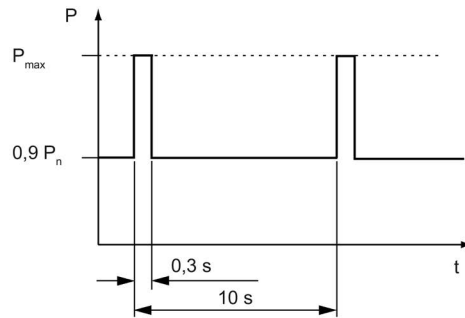

Figure 4-59 Duty cycles with initial load

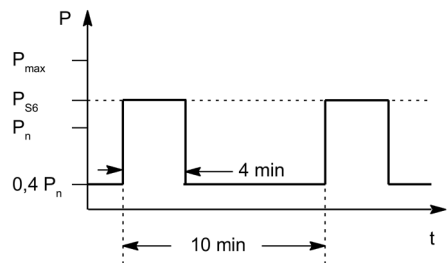
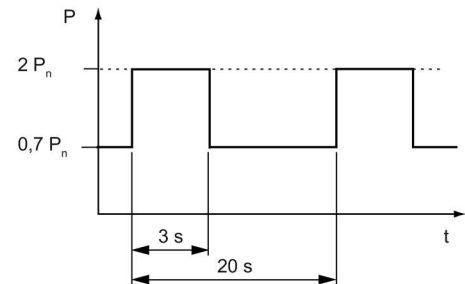

Figure 4-60 S6 duty cycle with pre-load condition

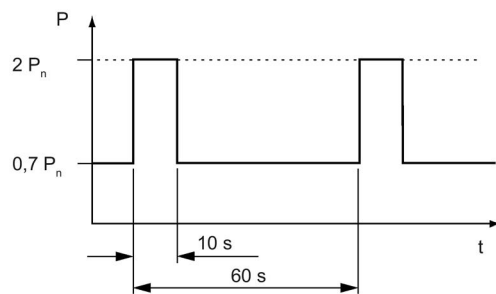

Figure 4-61 Duty cycle with pre-load condition for 20 kW and 40 kW Basic Line Modules

Braking duty cycle for Basic Line Modules

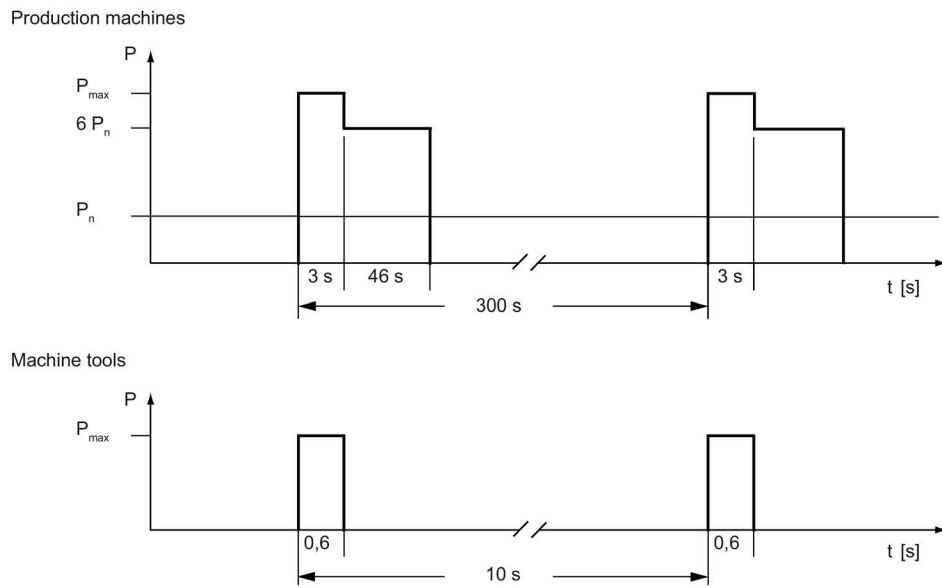

Figure 4-62 Braking duty cycle for Basic Line Modules

4.9 Smart Line Modules with internal air cooling

4.9.1 Description

The Smart Line Module is a non-regulated infeed/regenerative feedback unit. The Smart Line Module supplies the Motor Module with a non-regulated DC voltage at the DC output. In the infeed mode the Smart Line Module exhibits the typical current and voltage waveforms of a 6-pulse diode rectifier bridge.

In feedback mode, the current waveform is square waved. Regenerative feedback can be deactivated if required. On 5 kW and 10 kW Smart Line Modules, this is realized via a terminal, since these modules do not feature a DRIVE-CLiQ connection. On 16 kW to 55 kW Smart Line Modules, regenerative feedback can be deactivated via parameters, as, just like Active Line Modules, these modules are equipped with a DRIVE-CLiQ connection.

The DC link starts precharging as soon as the line voltage is applied and is independent of its phase sequence direction. Load can be applied to the DC link after the module has been enabled.

A line contactor can be installed on the line side if the system has to be electrically isolated from the line supply.

Smart Line Modules are suitable for direct operation on TN, IT and TT systems. The Line Modules have an integrated overvoltage protection function.

4.9.2 Additional safety instructions for Smart Line Modules Booksize

<p>NOTICE</p> <p>Damage to the Smart Line Module for an incorrect switch-on or switch-off sequence</p> <p>It is essential that an appropriate switch-on and switch-off sequence (Page 248) is complied with in order to control the 5 kW and 10 kW Smart Line Modules; if this sequence is not observed, the Smart Line Module could be damaged beyond repair.</p> <ul style="list-style-type: none"> • Comply with the specified switching sequence.
--

Note

Connected to the public low-voltage network

Smart Line Modules have been designed for use in the industrial environment and generate current harmonics on the line side as a result of the rectifier circuit.

When connecting a machine with integrated Smart Line Modules to the public low-voltage line supply (grid), authorization is required in advance from the local power supply company (utility company) in the following cases:

- The rated current of the motor ≤ 16 A per conductor.
- The rated motor current does not comply with the requirements specified in EN 61000-3-2 regarding current harmonics.

4.9.3 Switch-on/switch-off sequence for 5 kW and 10 kW Smart Line Modules

It is essential that the subsequently described switch-on and switch-off sequence is complied with in order to control the 5 kW and 10 kW Smart Line Modules; if this sequence is not observed, the Smart Line Module could be destroyed.

Observe the "Ready" signal at output terminal X21.1:

Switching on

1. 24 V DC supply X24 ON
2. Line contactor ON
3. EP signal X21.3 and X21.4 ON
4. Wait until precharging has been completed
5. "Ready" signal at terminal X21.1 switched to high
6. Infeed is ready, pulse enable possible for motors

Switching off

1. Shut drives down
2. Cancel pulse enable for motors (OFF1 signal)
3. EP signal X21.3 and X21.4 OFF
4. Line contactor OFF
5. 24 V DC supply X24 OFF

Overload

1. "Prewarning" signal at terminal X21.2 switches to low
2. Shut drives down via the control system
3. "Ready" signal at terminal X21.1 switches to low
4. Pulse inhibit for all the drives supplied by this infeed within 4 ms

4.9.4 Interface description

4.9.4.1 Overview

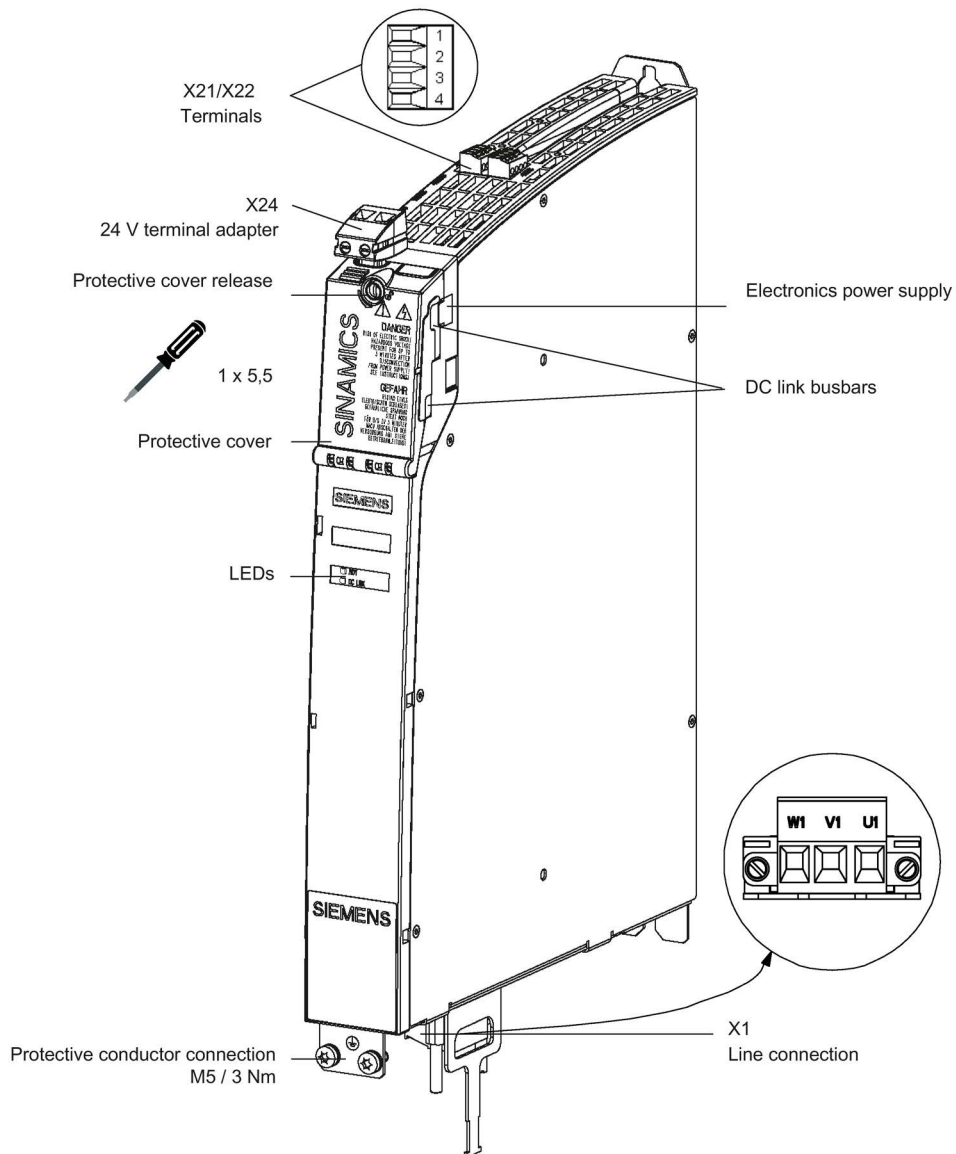

Figure 4-63 Interface overview, 5 kW and 10 kW Smart Line Modules with internal air cooling (example: 5 kW)

4.9 Smart Line Modules with internal air cooling

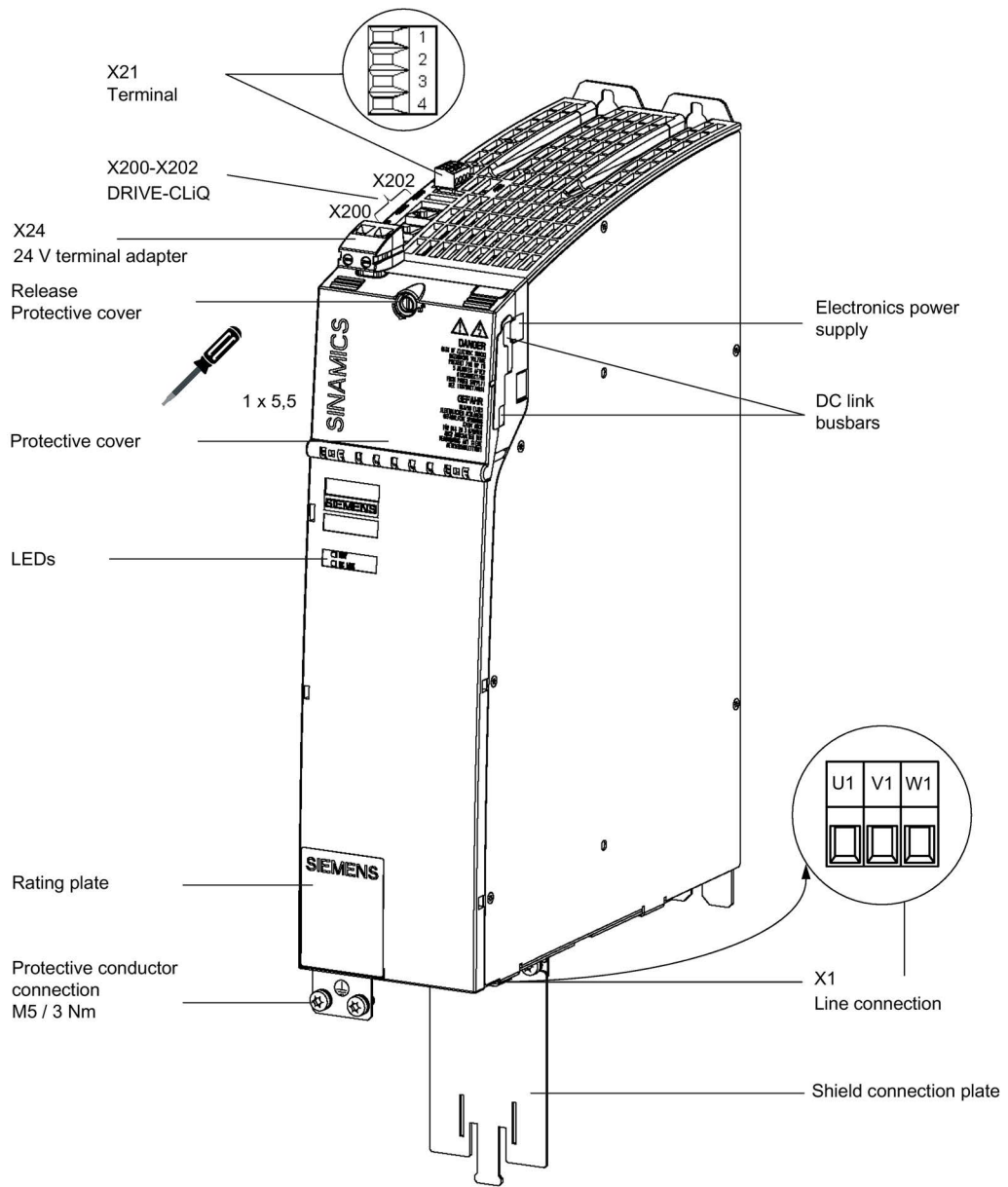

Figure 4-64 Interface overview, 16 kW Smart Line Module with internal air cooling

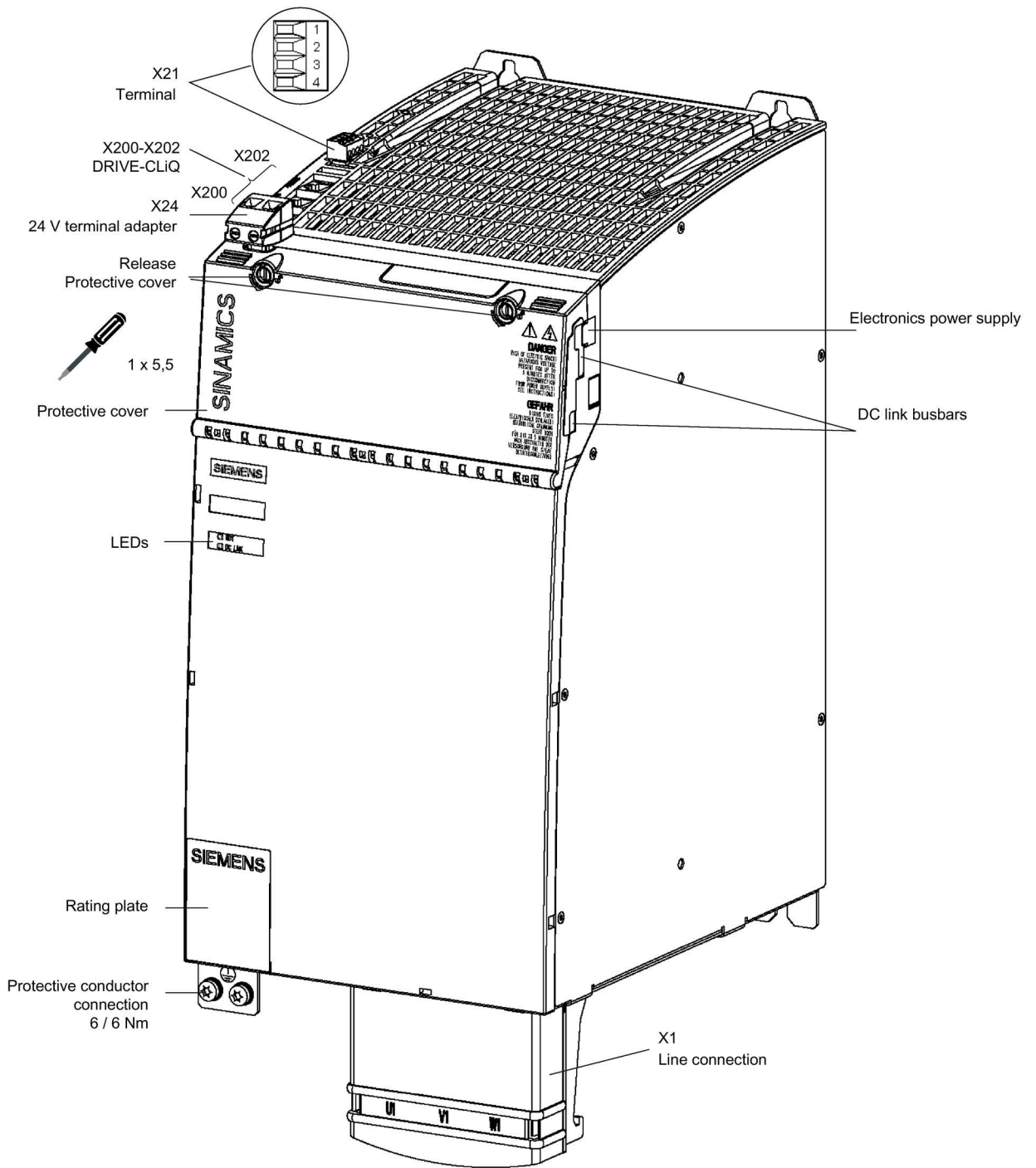

Figure 4-65 Interface overview, 36 kW and 55 kW Smart Line Modules with internal air cooling (example: 55 kW)

4.9 Smart Line Modules with internal air cooling

4.9.4.2 X1 line connection

Table 4- 63 X1: Line connection for Smart Line Modules 5 kW and 10 kW

	Terminal	Technical data
	U1	Supply voltage: 3 AC 380 ... 480 V, 50 / 60 Hz Type: Screw terminal 5 (Page 708)
	V1	
	W1	
	Protective conductor connection	Threaded hole M5 / 3 Nm (26.6 lbf in) ¹⁾
¹⁾ For ring cable lugs without insulation (Page 710)		

Table 4- 64 X1: Line supply connection for Smart Line Modules 16 kW

	Terminal	Technical data
	U1	Supply voltage: 3 AC 380 ... 480 V, 50 / 60 Hz Type: Screw terminal 6 (Page 708)
	V1	
	W1	
	Protective conductor connection	Threaded hole M5 / 3 Nm (26.6 lbf in) ¹⁾
¹⁾ For ring cable lugs without insulation (Page 710)		

Table 4- 65 X1: Line connection for Smart Line Modules 36 kW and 55 kW

	Terminal	Technical data
	U1 V1 W1	Supply voltage: 3 AC 380 ... 480 V, 50 / 60 Hz 36 kW: Threaded bolt M6 / 6 Nm (53.1 lbf in) ¹⁾ 55 kW: Threaded bolt M8 / 13 Nm (115 lbf in) ¹⁾
	Protective conductor connection	36 kW and 55 kW: Threaded hole M6 / 6 Nm (53.1 lbf in) ¹⁾
¹⁾ For ring cable lugs without insulation (Page 710)		

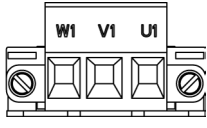
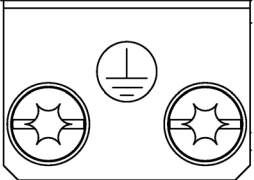
4.9.4.3 X21 EP terminals

Smart Line Modules 5 kW and 10 kW

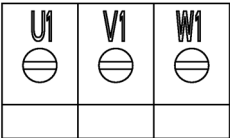
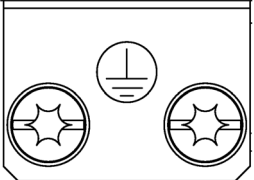
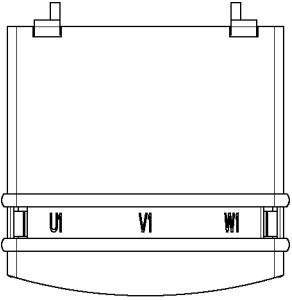
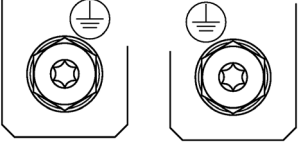
Table 4- 66 X21 EP terminal for Smart Line Modules 5 kW and 10 kW

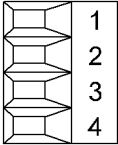
	Terminal	Designation	Technical data
	1	DO: Ready	Feedback signal: Smart Line Module ready The signal switches to high level when the following conditions have been met: <ul style="list-style-type: none"> • Electronics power supply (X24) OK • DC link is precharged • Pulses enabled (X21.3/4) • No overtemperature • No overcurrent
	2	DO: Prewarning	DO: Prewarning High = no prewarning Low = prewarning <ul style="list-style-type: none"> • Overtemperature warning threshold/I²t 5 kW prewarning: 64 °C, overtemperature threshold: 69 °C 10 kW prewarning: 68 °C, overtemperature threshold: 73 °C • No regenerative feedback capability due to a line fault [only monitored when feedback is activated (see terminal X22.2)]
	3	EP +24 V (pulse enable)	Voltage: 24 V DC (20.4 ... 28.8 V)
	4	EP M (Enable Pulses)	Current consumption, typical: 4 mA at 24 V Isolated input
Type: Screw terminal 1 (Page 708)			

Terminals X21.1 and X21.2

Note

Wiring to a digital input of the Control Unit

Output terminal X21.1 must be wired to a digital input on the CU. The drives supplied with power from the Smart Line Module have to use this signal as a ready signal. This ensures that a pulse enable can only be issued for the drives (motor or generator operation) when the infeed is ready.

If interconnection with a digital input on the CU is not possible, the signal must be evaluated by a higher-level control system instead. It is not permissible that the control system sets the drives to ready until the infeed "Ready" signal is present.

Note**Evaluating the "Prewarning" signal**

The "Prewarning" signal at output terminal X21.2 warns against an overload. If this signal is set to low, the control system shuts the drives down before the "Ready" signal switches to low. If the "Ready" signal switches to "low", the drive pulses must be suppressed within 4 ms.

Note

The Smart Line Module signals "Ready" (X21.1 = High), even if one of the line conductor voltages is not available. In this case, regenerative feedback is deactivated and an alarm is output at X21.2 (DO, Warning I²t low signal).

If regenerative feedback was deactivated by applying a "high" signal to terminal X22.2 (DI, Disable), no alarm will be output at X21.2 (DO, Warning I²t).

Terminals X21.3 and X21.4

For operation, the 24 V DC voltage must be connected to terminal X21.3 and ground to terminal X21.4.

Pulse cancellation is activated if the power supply is disconnected. As a consequence, regenerative feedback is deactivated and the bypass relay drops out. If the Line Module is not disconnected from the line supply when the EP terminal is de-energized, for example, because a line contactor is not installed, then the DC link remains charged.

16 kW to 55 kW Smart Line Modules

Table 4- 67 X21 EP terminal / temperature sensor for 16 kW to 55 kW Smart Line Modules

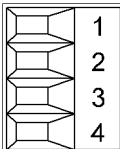
	Terminal	Function	Technical data
	1	+ Temp	Temperature sensors ¹⁾ : KTY84–1C130 / PT1000 / PTC / bimetallic switch with NC contact
	2	- Temp	
	3	EP +24 V (pulse enable)	Voltage: 24 V DC (20.4 ... 28.8 V) Current consumption, typical: 4 mA at 24 V Isolated input
	4	EP M (Enable Pulses)	
Type: Screw terminal 1 (Page 708)			

¹⁾ The temperature sensor type and the temperature output can be selected by parameter (see the SINAMICS S120/S150 List Manual).

Temperatures are sensed, but are not evaluated in the Smart Line Module.

Terminals X21.1 and X21.2 - temperature sensor connection



⚠ WARNING
<p>Electric shock in the event of voltage flashovers on the temperature sensor cable</p> <p>Voltage flashovers in the signal electronics can occur in motors without safe electrical separation of the temperature sensors.</p> <ul style="list-style-type: none"> • Only use temperature sensors that fully comply with the specifications of protective separation. • If safe electrical separation cannot be guaranteed (for linear motors or third-party motors, for example), use a Sensor Module External (SME120 or SME125) or Terminal Module TM120.

NOTICE
<p>Damage to motor in the event of incorrectly connected KTY temperature sensor</p> <p>A KTY temperature sensor connected with incorrect polarity cannot detect if the motor overheats. Overheating can cause damage to the motor.</p> <ul style="list-style-type: none"> • Connect the KTY temperature sensor with the correct polarity.

Terminals X21.3 and X21.4

For operation, the 24 V DC voltage must be connected to terminal X21.3 and ground to terminal X21.4.

Pulse cancellation is activated if the power supply is disconnected. As a consequence, regenerative feedback is deactivated and the bypass relay drops out. If the Line Module is not disconnected from the line supply when the EP terminal is de-energized, for example, because a line contactor is not installed, then the DC link remains charged.

4.9.4.4 X22 digital inputs

Table 4- 68 X22 digital inputs for Smart Line Modules 5 kW and 10 kW

	Terminal	Designation¹⁾	Technical data
	1	24 V power supply	Electronics power supply for controlling digital inputs X22.2 and 3
	2	DI: Disable Regeneration	Deactivate regenerative feedback (high active) No power is supplied back to the network from the DC link. The regenerative energy of the motors may have to be reduced using a combination of the Braking Module and braking resistor.
	3	DI: Reset	Reset faults (negative edge)
	4	Ground	Electronics ground
Type: Screw terminal 1 (Page 708)			

¹⁾ DI: Digital input

4.9.4.5 X24 24 V terminal adapter

Table 4- 69 X24: 24 V terminal adapter

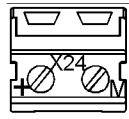
	Terminal	Designation	Technical data
	+	24 V power supply	24 V DC supply voltage
	M	Ground	Electronics ground
Type: Screw terminal 5 (Page 708)			

The 24 V terminal adapter is included in the scope of supply.

4.9.4.6 X200-X202 DRIVE-CLiQ interfaces

Table 4- 70 X200-X202: DRIVE-CLiQ interfaces

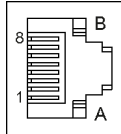
	PIN	Signal name	Technical data
	1	TXP	Transmit data +
	2	TXN	Transmit data -
	3	RXP	Receive data +
	4	Reserved, do not use	-
	5	Reserved, do not use	-
	6	RXN	Receive data -
	7	Reserved, do not use	-
	8	Reserved, do not use	-
	A	+(24 V)	24 V power supply
	B	M (0 V)	Electronics ground

The blanking covers for the DRIVE-CLiQ interfaces are included in the scope of delivery.

Blanking cover (50 pcs.) Article number: 6SL3066-4CA00-0AA0

4.9.5 Connection examples

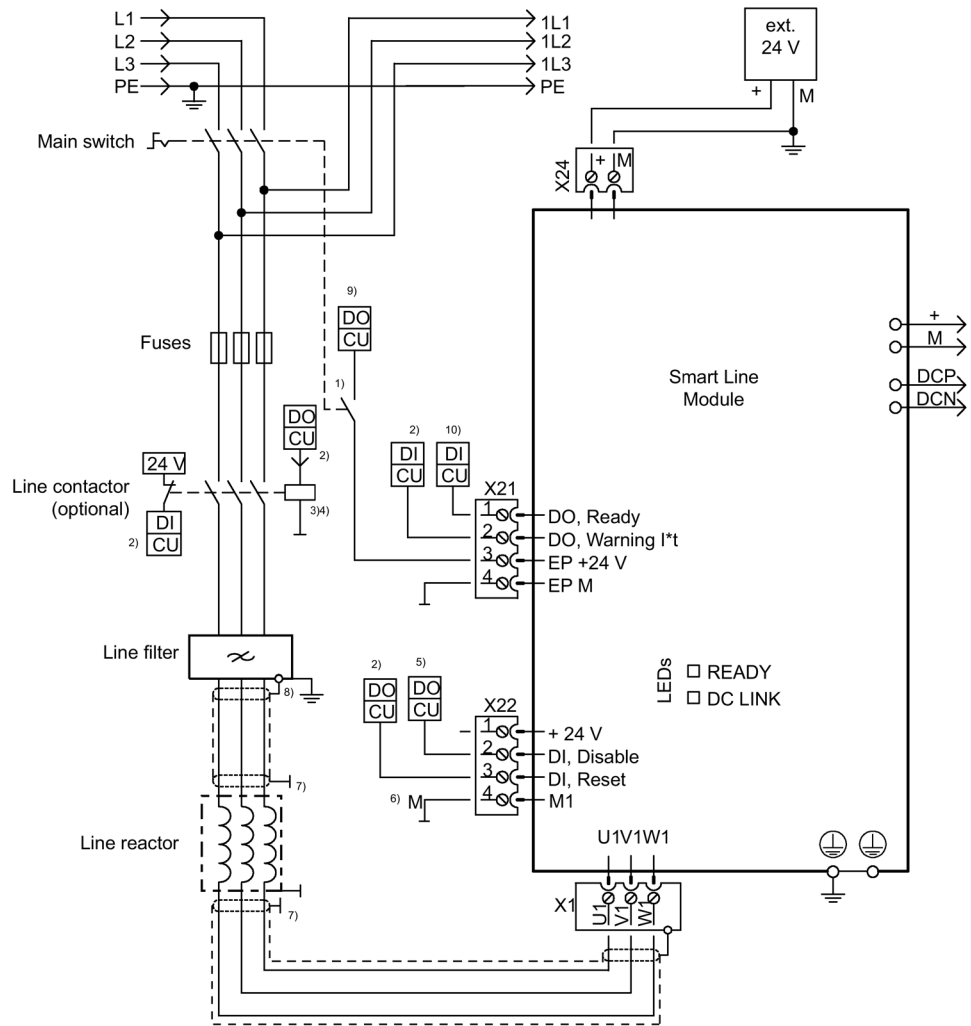

- 1) Leading opening contact $t > 10$ ms; 24 V DC and ground must be connected for operation.
- 2) DI/DO, controlled by the Control Unit
- 3) No additional load permitted downstream of the line contactor
- 4) The current carrying capacity of the DO must be observed; an output coupling device may have to be used.
- 5) DO high, feedback deactivated (a bridge can be installed between X22 pin 1 and 2 for permanent deactivation)
- 6) X22 pin 4 must be connected with ground (ext. 24 V)
- 7) Contact established through the rear mounting panel or shield rails in accordance with the EMC installation guideline
- 8) 5 kW and 10 kW line filter via shield connection
- 9) Signal output of controller to prevent reaction of 24 V DC supply on EP terminal
- 10) Interconnection via BiCo to parameter p0864

Figure 4-66 Connection example for 5 kW and 10 kW Smart Line Modules

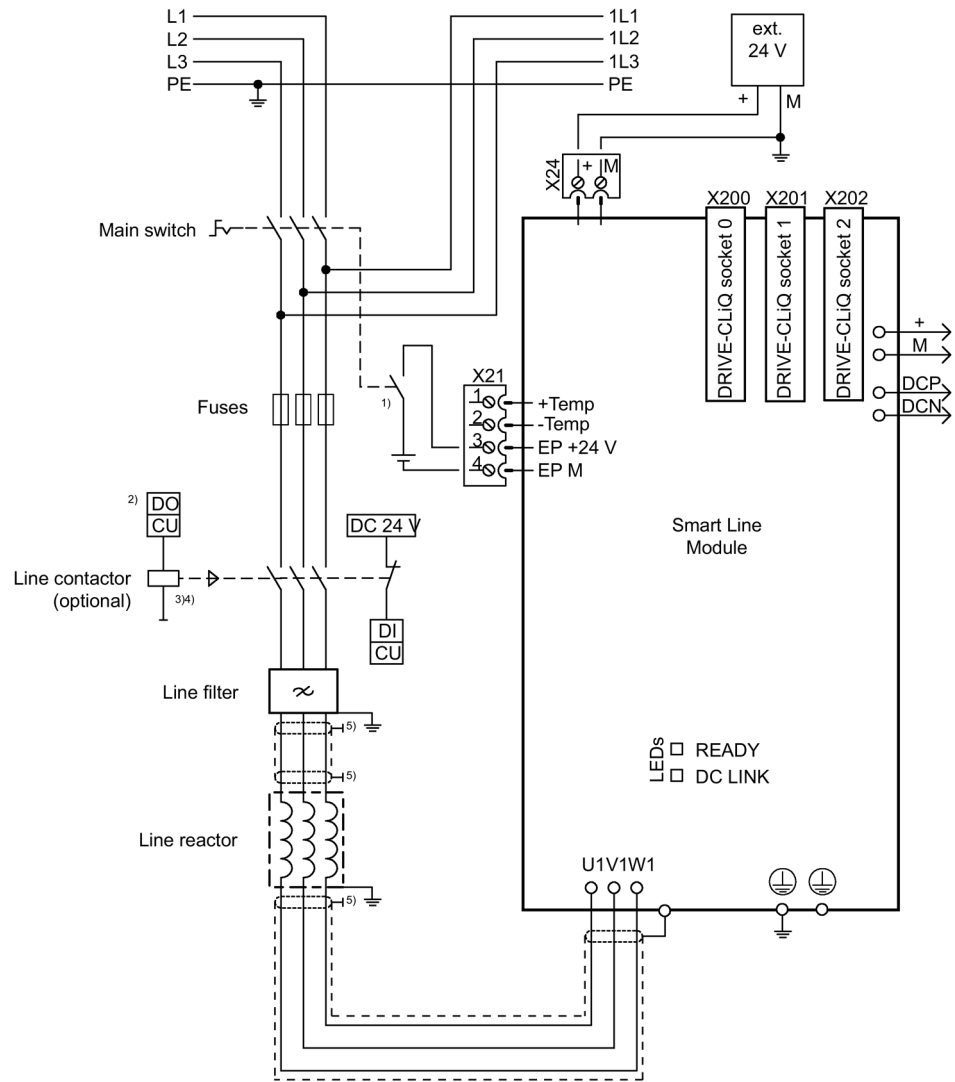

- 1) Leading opening contact, $t > 10$ ms
- 2) DI/DO, controlled from the Control Unit
- 3) No additional load/consumer is permitted after the line contactor
- 4) The current carrying capacity of the DO must be observed; an output coupling device may have to be used.
- 5) Contact established through the rear mounting panel or shield rails in accordance with the EMC installation guideline

Figure 4-67 Connection example for 16 kW to 55 kW Smart Line Modules

Note

If you are using a VSM10 Voltage Sensing Module, the leading opening contact can be omitted.

4.9.6 Meaning of LEDs

4.9.6.1 Smart Line Modules 5 kW and 10 kW

Table 4- 71 Meaning of the LEDs on 5 kW and 10 kW Smart Line Modules

LED	Color	Status	Description, cause	Remedy
RDY	–	Off	The electronics power supply is missing or outside the permissible tolerance range.	–
	Green	Continuous light	The component is ready for operation.	–
	Orange	Continuous light	The precharging has not yet been completed. The bypass relay has dropped out. The EP terminals are not supplied with 24 V DC.	–
	Red	Continuous light	Overtemperature overcurrent	Diagnose the fault (using the output terminals) and acknowledge (using the input terminal).
DC LINK	Orange	Continuous light	The DC link voltage is within permissible tolerance range.	–
	Red	Continuous light	The DC link voltage is outside the permissible tolerance range or a line fault is present.	Check the line supply voltage.

4.9.6.2 16 kW to 55 kW Smart Line Modules

Table 4- 72 Meaning of the LEDs on Smart Line Modules \geq 16 kW

Status		Description, cause	Remedy
RDY	DC LINK		
Off	Off	The electronics power supply is missing or outside the permissible tolerance range.	–
Green	-- ¹⁾	The component is ready for operation. Cyclic DRIVE-CLiQ communication is taking place.	–
	Orange	The component is ready for operation. Cyclic DRIVE-CLiQ communication is taking place. The DC link voltage is present.	–
	Red	The component is ready for operation. Cyclic DRIVE-CLiQ communication is taking place. The DC link voltage is outside the permissible tolerance range.	Check the line supply voltage.
Orange	Orange	DRIVE-CLiQ communication is being established.	–
Red	-- ¹⁾	This component has at least one fault.	Resolve and acknowledge the fault.
Green/red (0.5 Hz)	-- ¹⁾	Firmware is being downloaded.	–
Green/red (2 Hz)	-- ¹⁾	Firmware download has been completed. The system waits for POWER ON.	Carry out a POWER ON.
Green/orange or red/orange	-- ¹⁾	Component recognition via LED is activated ²⁾ . Note: Both options depend on the LED status when component recognition is activated.	–

1) Irrespective of the status of the LED "DC LINK"

2) For information about activating the parameter "Recognition via LED", see SINAMICS S120/S150 List Manual

4.9.7 Dimension drawings

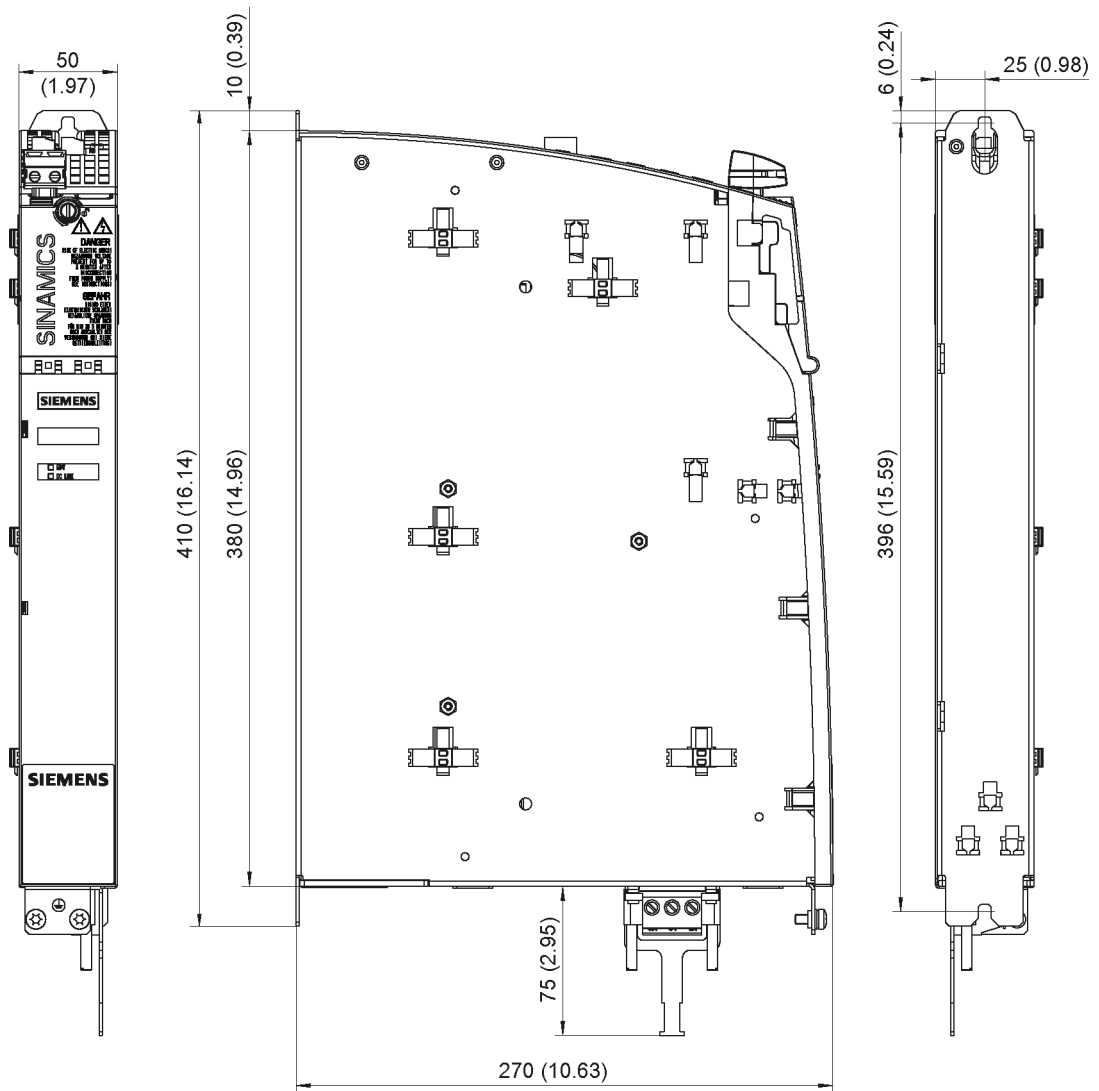

Figure 4-68 Dimension drawing of 5 kW and 10 kW Smart Line Modules with internal air cooling, all dimensions in mm and (inches)

Note

The shield connecting plate is integrated in the line connector of the 50 mm Smart Line Modules.

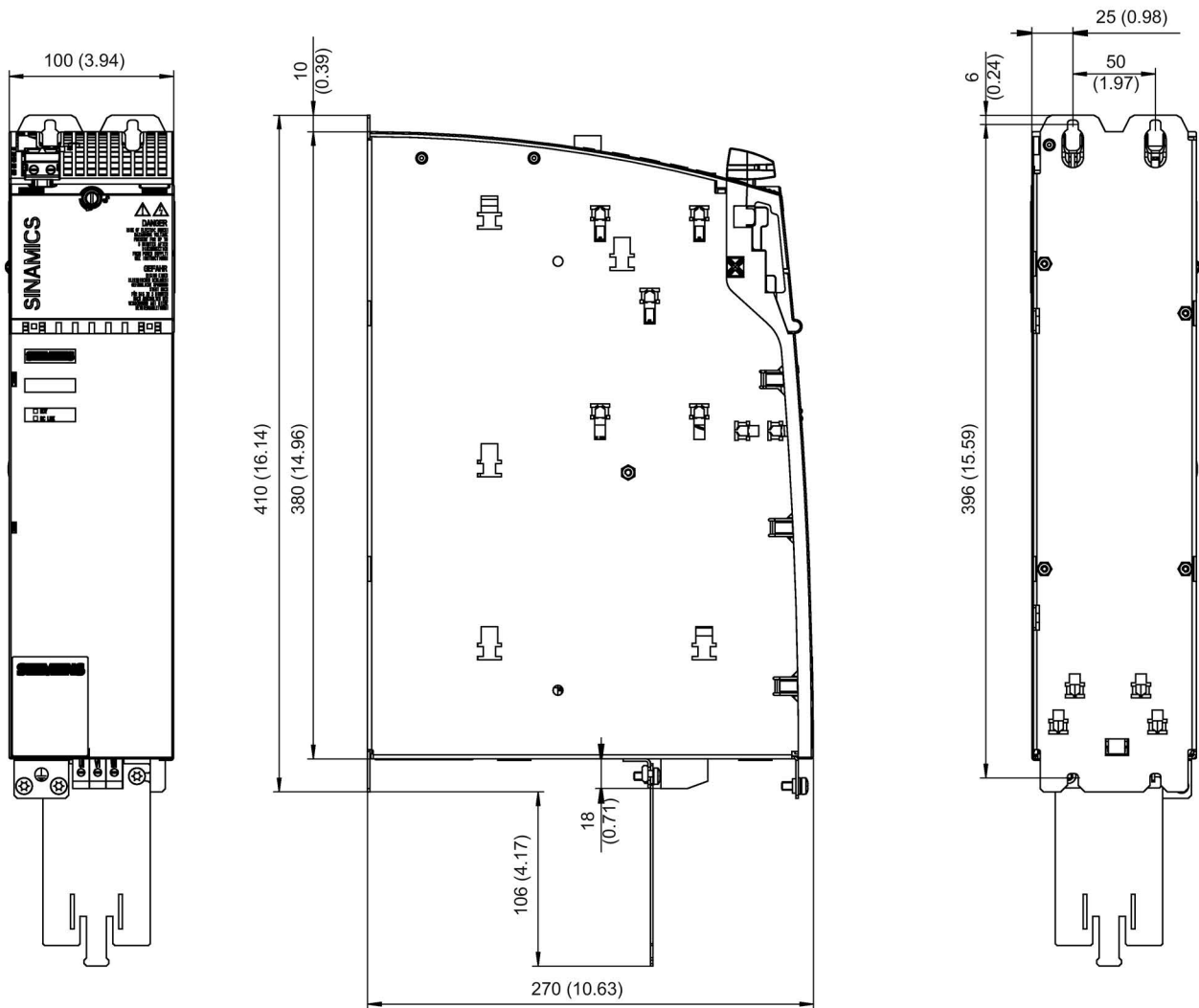

Figure 4-69 Dimension drawing of 16 kW Smart Line Module with internal air cooling, all dimensions in mm and (inches)

Note

The shield connecting plate is part of the scope of delivery of the 100 mm Smart Line Modules.

4.9 Smart Line Modules with internal air cooling

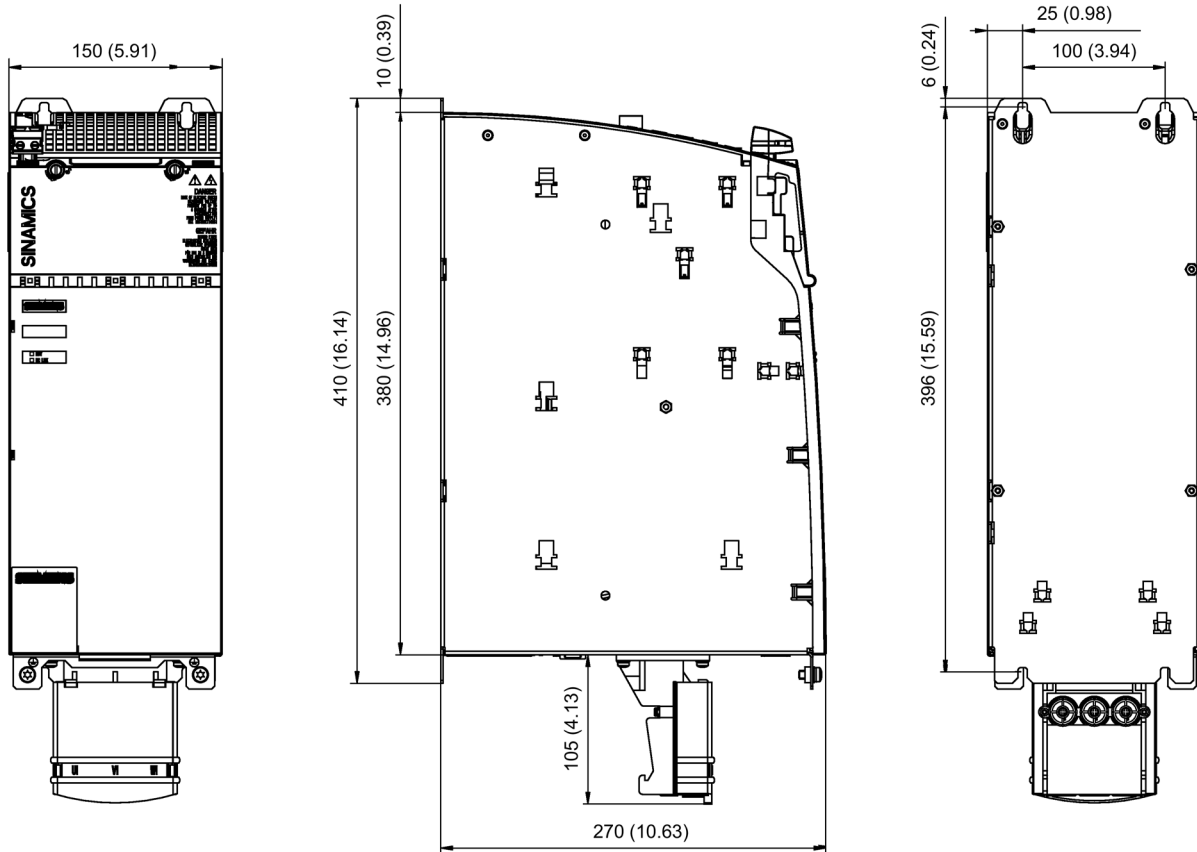

Figure 4-70 Dimension drawing of 36 kW Smart Line Module with internal air cooling, all dimensions in mm and (inches)

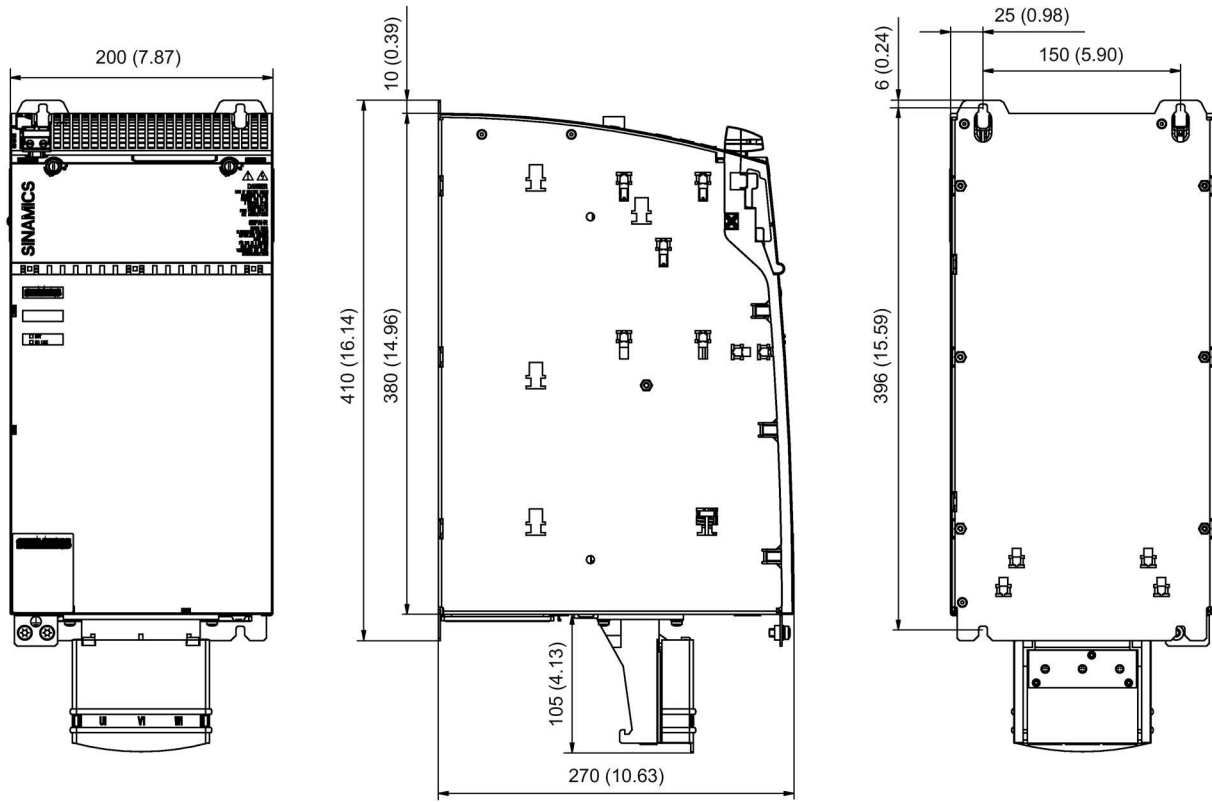
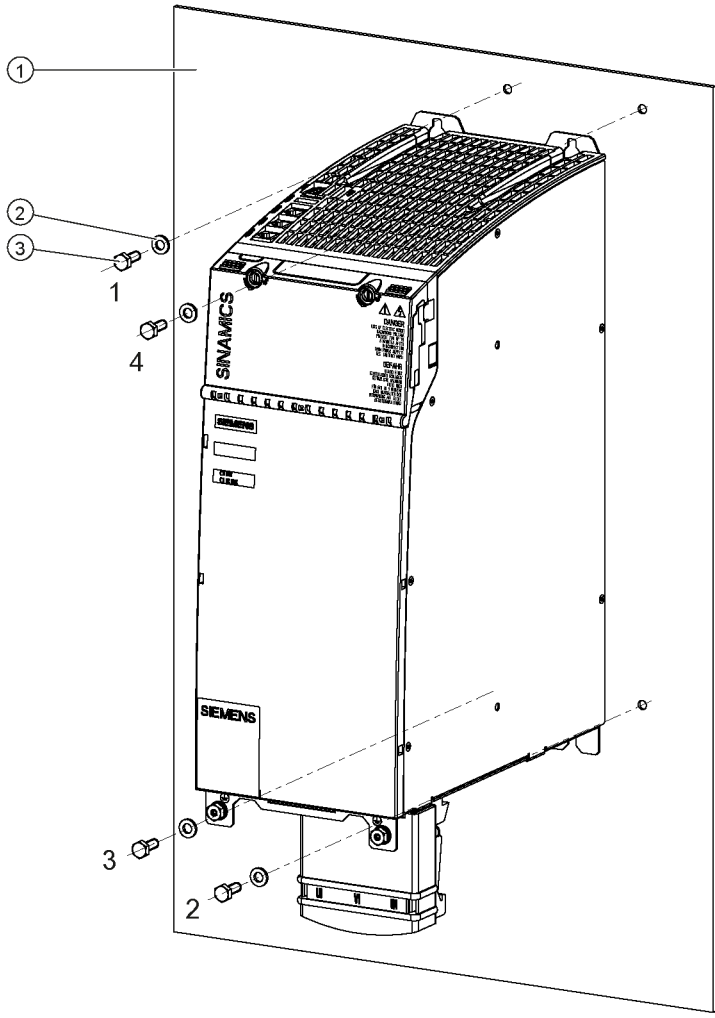

Figure 4-71 Dimension drawing of 55 kW Smart Line Module with internal air cooling, all dimensions in mm and (inches)

4.9.8 Installation

Smart Line Modules are designed for installation in the control cabinet. They are fixed to the control cabinet panel or a mounting panel using M6 screws.



- ① Control cabinet panel/mounting panel
- ② Washer
- ③ M6 screw

Figure 4-72 Mounting a Smart Line Module with internal air cooling (example: 36 kW)

Tightening torques:

1. Firstly, tighten the nuts by hand.
Tightening torque. 0.5 Nm (4.4 lbf in)
2. Then tighten the nuts in the specified sequence 1 to 4.
Tightening torque: 6 Nm (53.1 lbf in)

4.9.9 Technical data

Table 4- 73 Technical data for Smart Line Modules in booksize format with internal air cooling

Internal air cooling	6SL3130-	6AE15-0A..	6AE21-0A..	6TE21-6A..	6TE23-6A..	6TE25-5AA.
Rated power	kW	5	10	16	36	55
Infeed¹⁾						
Rated power S1 duty	kW (P _n)	5	10	16	36	55
Infeed power S6 duty (40 %)	kW (P _{S6})	6.5	13	21	47	71
Peak infeed power	kW (P _{max})	10	20	35	70	91
Regenerative feedback						
Continuous regenerative power	kW	5	10	16	36	55
Peak regenerative power	kW	10	20	35	70	91
Supply voltages		3 AC 380 ... 480 ± 10 % (-15 % < 1 min)				
Line voltage	V _{AC}	47 ... 63				
Line frequency	Hz	24 (20.4 ... 28.8)				
Electronics power supply	V _{DC}	510 ... 720				
DC-link voltage	V _{DC}	820 ± 2 %				
Overvoltage trip	V _{DC}	360 ± 2 %				
Undervoltage trip ²⁾	V _{DC}					
Input currents						
Rated input current						
at AC 400 V	A _{AC}	8.1	16.2	27.5	59	90
at AC 380 V / AC 480 V	A _{AC}	8.6 / 6.7	17 / 12.8	29 / 24.5	62 / 51	94 / 77
S6 duty (40 %) at AC 400 V	A _{AC}	10.6	21.1	35	76	106
Peak current at AC 400 V	A _{AC}	15.7	31.2	57.5	112	130
DC-link currents						
DC-link output current						
at 600 V DC	A _{DC}	8.3	16.6	27	60	92
at 510 V DC / 720 V DC	A _{DC}	9.3 / 6.9	19.6 / 13.9	30 / 22.2	67 / 50	92 / 76.4
S6 duty (40%) at 600 V DC	A _{DC}	11	22	35	79	138
Peak current at 600 V DC	A _{DC}	16.6	33.2	59	118	178
Current carrying capacity						
DC link busbars	A _{DC}	100	100	100	200	200
Reinforced DC link busbars	A _{DC}	150	150	150	--	--
24 V DC busbars	A _{DC}	20	20	20	20	20
Electronics current consumption						
at 24 V DC	A _{DC}	0.8	0.9	0.95	1.5	1.9
Total power loss						
(including electronics losses, see Power loss tables (Page 734))	W	79.2	141.6	187.8	406	665.6
DC link capacitance						
Smart Line Module	µF	220	330	705	1410	1880
Drive line-up, max.	µF	6000	6000	20000	20000	20000
Power factor	cos φ	0.98				
Circuit breaker (IEC 60947 and UL)		See Chapter Overcurrent protection using fuses and circuit breakers (Page 47)				

4.9 Smart Line Modules with internal air cooling

Internal air cooling	6SL3130-	6AE15-0A..	6AE21-0A..	6TE21-6A..	6TE23-6A..	6TE25-5AA.
Rated power	kW	5	10	16	36	55
Max. total cable length³⁾		See Chapter Combination options, Line Modules with line reactors and line filters (Page 120)				
Sound pressure level	dB(A)	< 60	< 60	< 60	< 65	< 60
Cooling method (internal air cooling)		Internal fan				
Cooling air requirement	m³/h	29.6	29.6	56	112	160
Max. permissible heat sink temperature	°C	69⁴⁾	73⁴⁾	77	80	75
Ventilation clearances above/below	mm	≥ 80				
Rated voltage for rated data 3 AC 380 V						
Weight	kg	4.7	4.8	7	10.7	16

- 1) The specified power ratings apply to the line voltage range from 380 V to 480 V.
- 2) For 16 kW and 36 kW Smart Line Modules: Default for 400 V line supplies; undervoltage trip threshold is adjusted to the parameterized rated voltage.
- 3) Maximum total cable length = Σ motor cables, line feeder cable from line filter to the Line Module
- 4) Values cannot be read out by the system (STARTER).

4.9.9.1 Characteristics

Rated duty cycles of Smart Line Modules

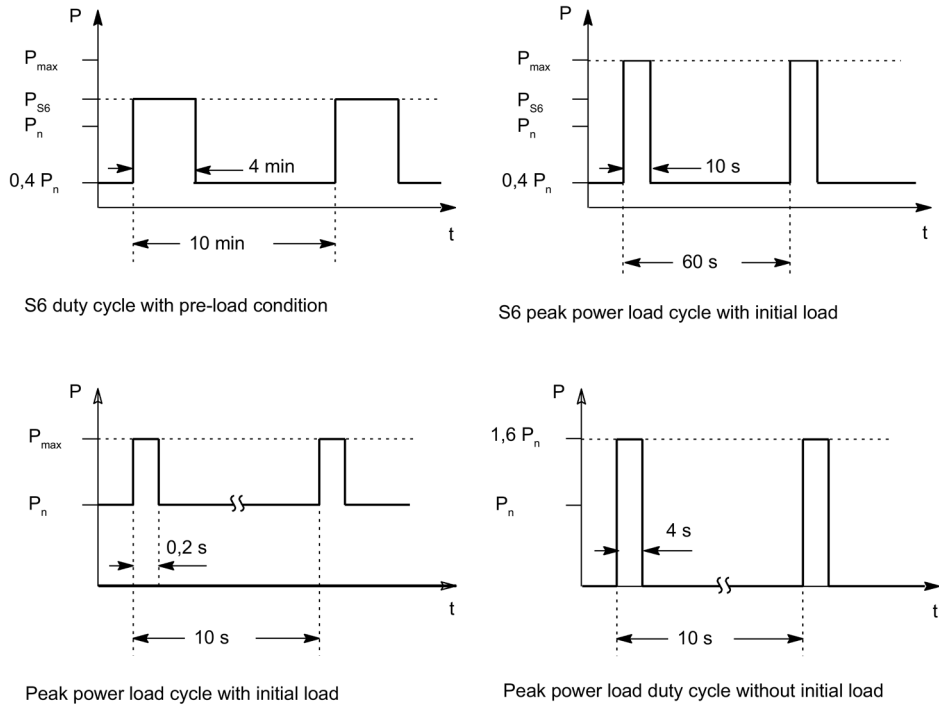

Figure 4-73 Rated duty cycles of Smart Line Modules

4.10 Smart Line Modules with external air cooling

4.10.1 Description

The Smart Line Module is a non-regulated infeed/regenerative feedback unit. The Smart Line Module supplies the Motor Module with a non-regulated DC voltage at the DC output. In the infeed mode the Smart Line Module exhibits the typical current and voltage waveforms of a 6-pulse diode rectifier bridge.

In feedback mode, the current waveform is square waved. Regenerative feedback can be deactivated if required. On 5 kW and 10 kW Smart Line Modules, this is done via a terminal, since these modules do not feature a DRIVE-CLiQ connection. On 16 kW to 55 kW Smart Line Modules, regenerative feedback can be deactivated via parameters, as, just like Active Line Modules, these modules are equipped with a DRIVE-CLiQ connection.

The DC link starts precharging as soon as the line voltage is applied and is independent of its phase sequence direction. Load can be applied to the DC link after the module has been enabled.

A line contactor can be installed on the line side if the system has to be electrically isolated from the line supply.

Smart Line Modules are suitable for direct operation on TN, IT and TT systems. The Line Modules have an integrated overvoltage protection function.

External air cooling uses the "through-hole" method. This is a cooling method that is only available for SINAMICS booksize units. The Smart Line Module and its heat sink can be inserted in a rectangular knockout at the rear of the control cabinet and mounted with a seal. The heat sink and the fan (included in the scope of supply) project beyond the rear of the control cabinet and the heat is dissipated outside the control cabinet or in a separate air duct.

4.10.2 Additional safety instructions for Smart Line Modules Booksize

NOTICE**Damage to the Smart Line Module for an incorrect switch-on or switch-off sequence**

It is essential that an appropriate switch-on and switch-off sequence (Page 272) is complied with in order to control the 5 kW and 10 kW Smart Line Modules; if this sequence is not observed, the Smart Line Module could be damaged beyond repair.

- Comply with the specified switching sequence.

Note**Connected to the public low-voltage network**

Smart Line Modules have been designed for use in the industrial environment and generate current harmonics on the line side as a result of the rectifier circuit.

When connecting a machine with integrated Smart Line Modules to the public low-voltage line supply (grid), authorization is required in advance from the local power supply company (utility company) in the following cases:

- The rated current of the motor ≤ 16 A per conductor.
- The rated motor current does not comply with the requirements specified in EN 61000-3-2 regarding current harmonics.

4.10.3 Switch-on/switch-off sequence for 5 kW and 10 kW Smart Line Modules

It is essential that the subsequently described switch-on and switch-off sequence is complied with in order to control the 5 kW and 10 kW Smart Line Modules; if this sequence is not observed, the Smart Line Module could be destroyed.

Observe the "Ready" signal at output terminal X21.1:

Switching on

1. 24 V DC supply X24 ON
2. Line contactor ON
3. EP signal X21.3 and X21.4 ON
4. Wait until precharging has been completed
5. "Ready" signal at terminal X21.1 switched to high
6. Infeed is ready, pulse enable possible for motors

Switching off

1. Shut drives down
2. Cancel pulse enable for motors (OFF1 signal)
3. EP signal X21.3 and X21.4 OFF
4. Line contactor OFF
5. 24 V DC supply X24 OFF

Overload

1. "Prewarning" signal at terminal X21.2 switches to low
2. Shut drives down via the control system
3. "Ready" signal at terminal X21.1 switches to low
4. Pulse inhibit for all the drives supplied by this infeed within 4 ms

4.10.4 Interface description

4.10.4.1 Overview

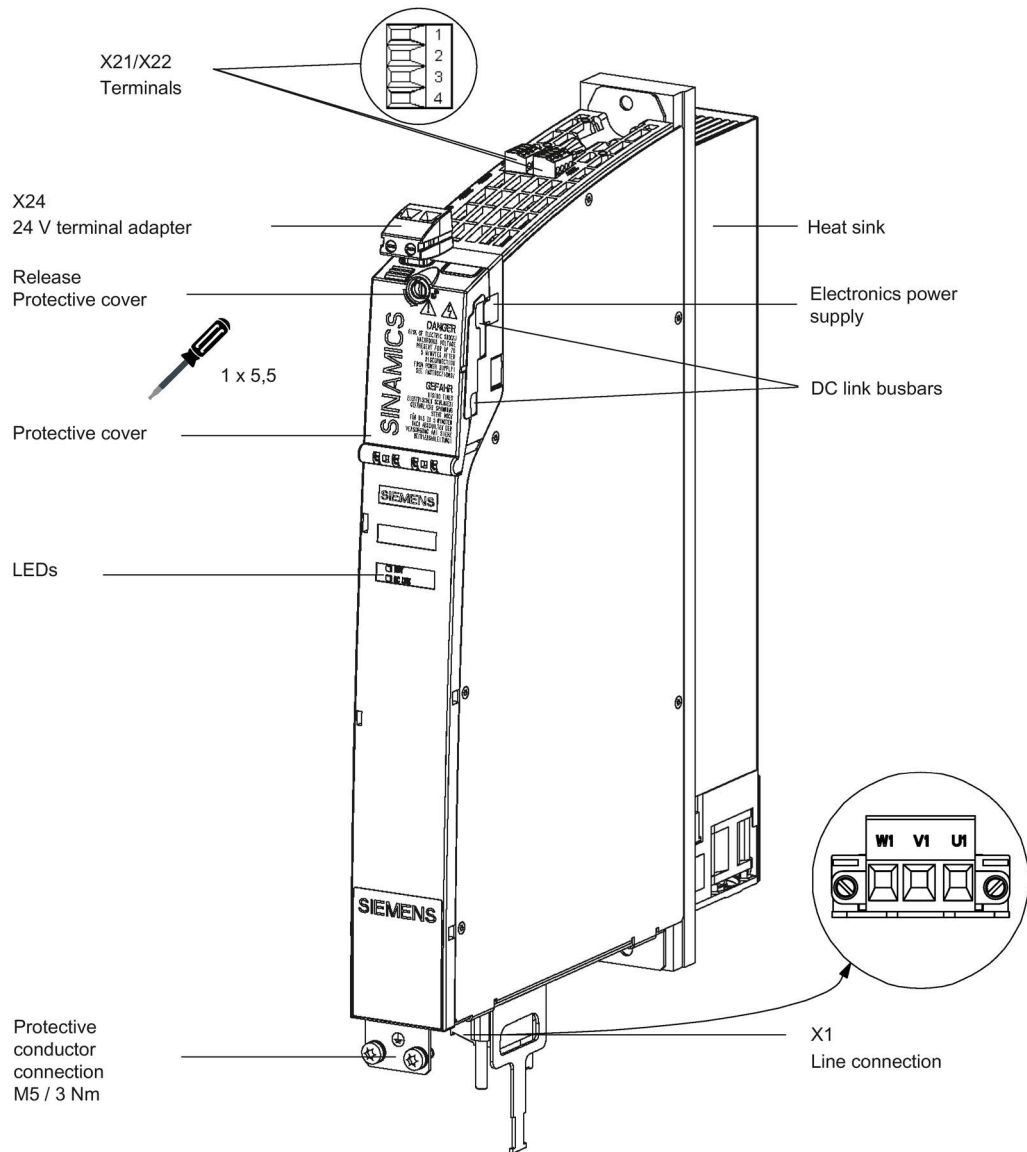

Figure 4-74 Interface overview, 5 kW and 10 kW Smart Line Modules with external air cooling (example: 5 kW)

4.10 Smart Line Modules with external air cooling

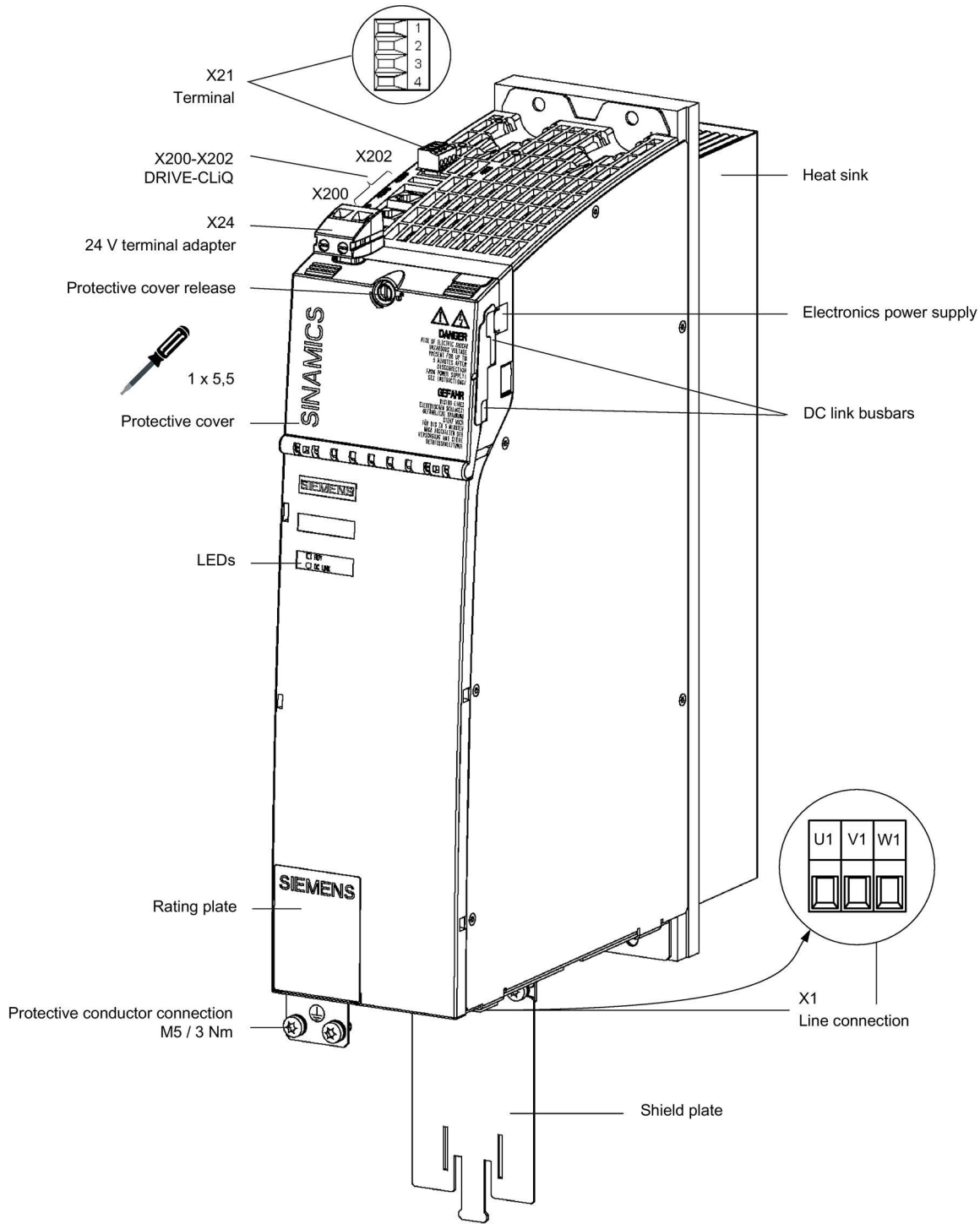

Figure 4-75 Interface overview, 16 kW Smart Line Module with external air cooling

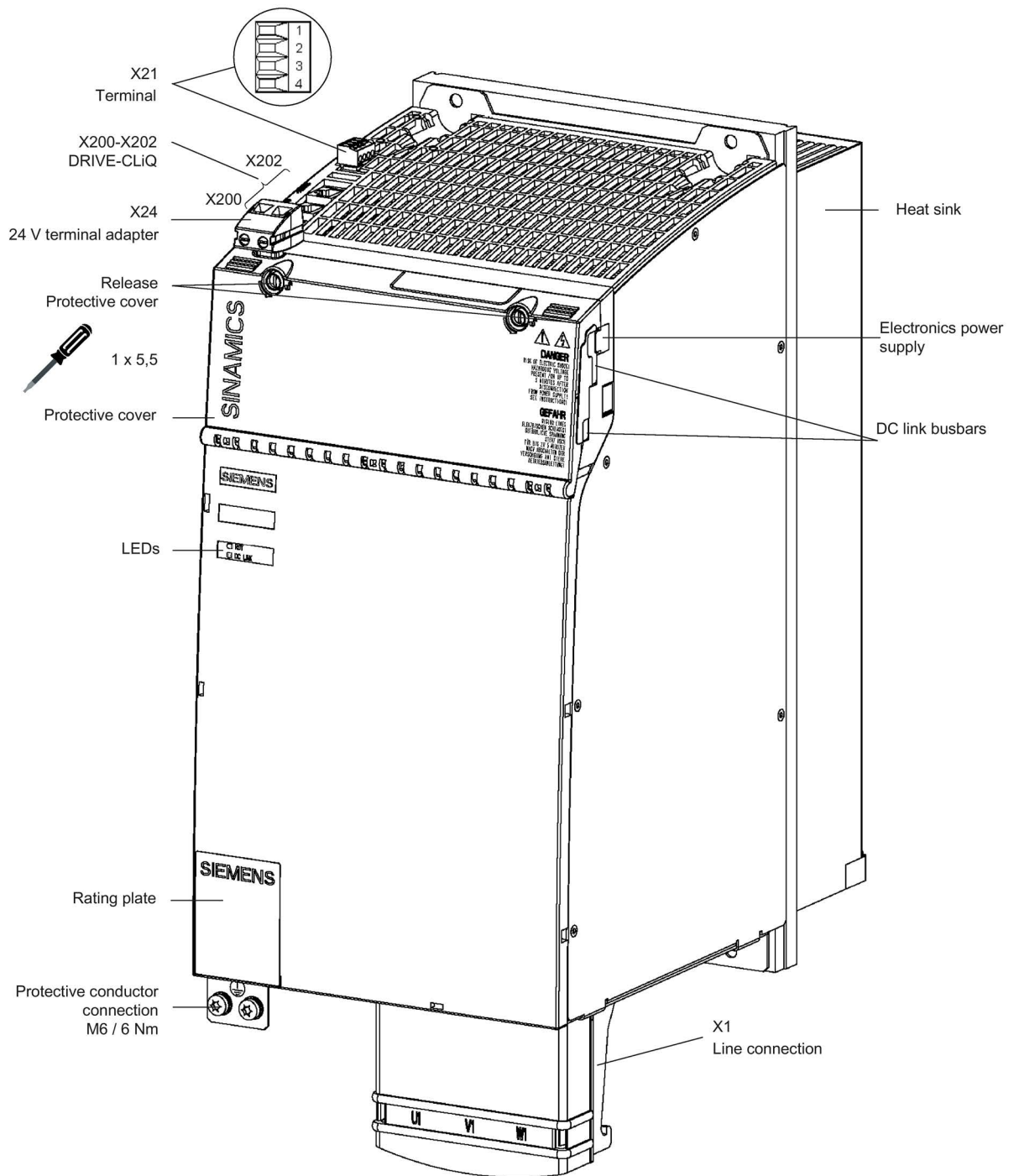

Figure 4-76 Interface overview, 36 kW and 55 kW Smart Line Modules with external air cooling (example: 55 kW)

4.10.4.2 X1 line connection

Table 4- 74 X1: Line connection for Smart Line Modules 5 kW and 10 kW

	Terminal	Technical data
	U1	Supply voltage: 3 AC 380 ... 480 V, 50 / 60 Hz Type: Screw terminal 5 (Page 708)
	V1	
	W1	
	Protective conductor connection	Threaded hole M5 / 3 Nm (26.6 lbf in) ¹⁾
¹⁾ For ring cable lugs without insulation (Page 710)		

Table 4- 75 X1: Line supply connection for Smart Line Modules 16 kW

	Terminal	Technical data
	U1	Supply voltage: 3 AC 380 ... 480 V, 50 / 60 Hz Type: Screw terminal 6 (Page 708)
	V1	
	W1	
	Protective conductor connection	Threaded hole M5 / 3 Nm (26.6 lbf in) ¹⁾
¹⁾ For ring cable lugs without insulation (Page 710)		

Table 4- 76 X1: Line connection for Smart Line Modules 36 kW and 55 kW

	Terminal	Technical data
	U1 V1 W1	Supply voltage: 3 AC 380 ... 480 V, 50 / 60 Hz 36 kW: Threaded bolt M6 / 6 Nm (53.1 lbf in) ¹⁾ 55 kW: Threaded bolt M8 / 13 Nm (115 lbf in) ¹⁾
	Protective conductor connection	36 kW and 55 kW: Threaded hole M6 / 6 Nm (53.1 lbf in) ¹⁾
¹⁾ For ring cable lugs without insulation (Page 710)		

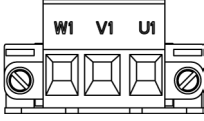
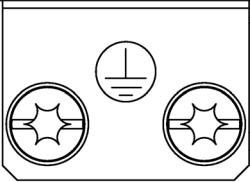
4.10.4.3 X21 EP terminals

Smart Line Modules 5 kW and 10 kW

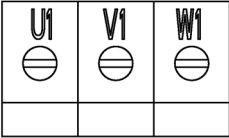
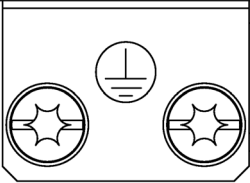
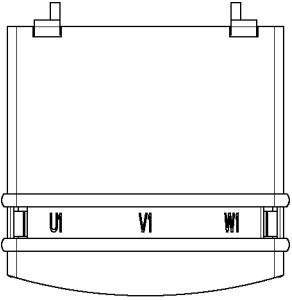
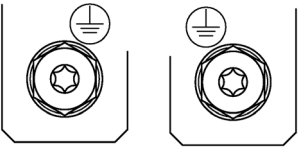
Table 4- 77 X21 EP terminal for Smart Line Modules 5 kW and 10 kW

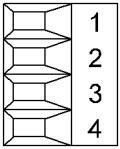
	Terminal	Designation	Technical data
	1	DO: Ready	Feedback signal: Smart Line Module ready The signal switches to high level when the following conditions have been met: <ul style="list-style-type: none"> • Electronics power supply (X24) OK • DC link is precharged • Pulses enabled (X21.3/4) • No overtemperature • No overcurrent
	2	DO: Prewarning	DO: Prewarning High = no prewarning Low = prewarning <ul style="list-style-type: none"> • Overtemperature warning threshold/I²t 5 kW prewarning: 64 °C, overtemperature threshold: 69 °C 10 kW prewarning: 68 °C, overtemperature threshold: 73 °C • No regenerative feedback capability due to a line fault [only monitored when feedback is activated (see terminal X22.2)]
	3	EP +24 V (pulse enable)	Voltage: 24 V DC (20.4 ... 28.8 V)
	4	EP M (Enable Pulses)	Current consumption, typical: 4 mA at 24 V Isolated input
Type: Screw terminal 1 (Page 708)			

Terminals X21.1 and X21.2

Note

Wiring to a digital input of the Control Unit

Output terminal X21.1 must be wired to a digital input on the CU. The drives supplied with power from the Smart Line Module have to use this signal as a ready signal. This ensures that a pulse enable can only be issued for the drives (motor or generator operation) when the infeed is ready.

If interconnection with a digital input on the CU is not possible, the signal must be evaluated by a higher-level control system instead. It is not permissible that the control system sets the drives to ready until the infeed "Ready" signal is present.

Note**Evaluating the "Prewarning" signal**

The "Prewarning" signal at output terminal X21.2 warns against an overload. If this signal is set to low, the control system shuts the drives down before the "Ready" signal switches to low. If the "Ready" signal switches to "low", the drive pulses must be suppressed within 4 ms.

Note

The Smart Line Module signals "Ready" (X21.1 = High), even if one of the line conductor voltages is not available. In this case, regenerative feedback is deactivated and an alarm is output at X21.2 (DO, Warning I²t low signal).

If regenerative feedback was deactivated by applying a "high" signal to terminal X22.2 (DI, Disable), no alarm will be output at X21.2 (DO, Warning I²t).

Terminals X21.3 and X21.4

For operation, the 24 V DC voltage must be connected to terminal X21.3 and ground to terminal X21.4.

Pulse cancellation is activated if the power supply is disconnected. As a consequence, regenerative feedback is deactivated and the bypass relay drops out. If the Line Module is not disconnected from the line supply when the EP terminal is de-energized, for example, because a line contactor is not installed, then the DC link remains charged.

16 kW to 55 kW Smart Line Modules

Table 4- 78 X21 EP terminal / temperature sensor for 16 kW to 55 kW Smart Line Modules

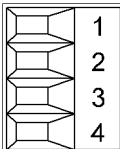
	Terminal	Function	Technical data
	1	+ Temp	Temperature sensors ¹⁾ : KTY84–1C130 / PT1000 / PTC / bimetallic switch with NC contact
	2	- Temp	
	3	EP +24 V (pulse enable)	Voltage: 24 V DC (20.4 ... 28.8 V) Current consumption, typical: 4 mA at 24 V Isolated input
	4	EP M (Enable Pulses)	
Type: Screw terminal 1 (Page 708)			

¹⁾ The temperature sensor type and the temperature output can be selected by parameter (see the SINAMICS S120/S150 List Manual).

Temperatures are sensed, but are not evaluated in the Smart Line Module.

Terminals X21.1 and X21.2 - temperature sensor connection



⚠ WARNING
<p>Electric shock in the event of voltage flashovers on the temperature sensor cable</p> <p>Voltage flashovers in the signal electronics can occur in motors without safe electrical separation of the temperature sensors.</p> <ul style="list-style-type: none"> • Only use temperature sensors that fully comply with the specifications of protective separation. • If safe electrical separation cannot be guaranteed (for linear motors or third-party motors, for example), use a Sensor Module External (SME120 or SME125) or Terminal Module TM120.

NOTICE
<p>Damage to motor in the event of incorrectly connected KTY temperature sensor</p> <p>A KTY temperature sensor connected with incorrect polarity cannot detect if the motor overheats. Overheating can cause damage to the motor.</p> <ul style="list-style-type: none"> • Connect the KTY temperature sensor with the correct polarity.

Terminals X21.3 and X21.4

For operation, the 24 V DC voltage must be connected to terminal X21.3 and ground to terminal X21.4.

Pulse cancellation is activated if the power supply is disconnected. As a consequence, regenerative feedback is deactivated and the bypass relay drops out. If the Line Module is not disconnected from the line supply when the EP terminal is de-energized, for example, because a line contactor is not installed, then the DC link remains charged.

4.10.4.4 X22 digital inputs

Table 4- 79 X22 digital inputs for Smart Line Modules 5 kW and 10 kW

	Terminal	Designation¹⁾	Technical data
	1	24 V power supply	Electronics power supply for controlling digital inputs X22.2 and 3
	2	DI: Disable Regeneration	Deactivate regenerative feedback (high active) No power is supplied back to the network from the DC link. The regenerative energy of the motors may have to be reduced using a combination of the Braking Module and braking resistor.
	3	DI: Reset	Reset faults (negative edge)
	4	Ground	Electronics ground
Type: Screw terminal 1 (Page 708)			

¹⁾ DI: Digital input

4.10.4.5 X24 24 V terminal adapter

Table 4- 80 X24: 24 V terminal adapter

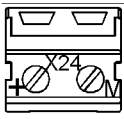
	Terminal	Designation	Technical data
	+	24 V power supply	24 V DC supply voltage
	M	Ground	Electronics ground
Type: Screw terminal 5 (Page 708)			

The 24 V terminal adapter is included in the scope of supply.

4.10.4.6 X200-X202 DRIVE-CLiQ interfaces

Table 4- 81 X200-X202: DRIVE-CLiQ interfaces

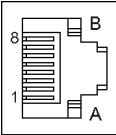
	PIN	Signal name	Technical data
	1	TXP	Transmit data +
	2	TXN	Transmit data -
	3	RXP	Receive data +
	4	Reserved, do not use	-
	5	Reserved, do not use	-
	6	RXN	Receive data -
	7	Reserved, do not use	-
	8	Reserved, do not use	-
	A	+(24 V)	24 V power supply
	B	M (0 V)	Electronics ground

The blanking covers for the DRIVE-CLiQ interfaces are included in the scope of delivery.

Blanking cover (50 pcs.) Article number: 6SL3066-4CA00-0AA0

4.10.5 Connection examples

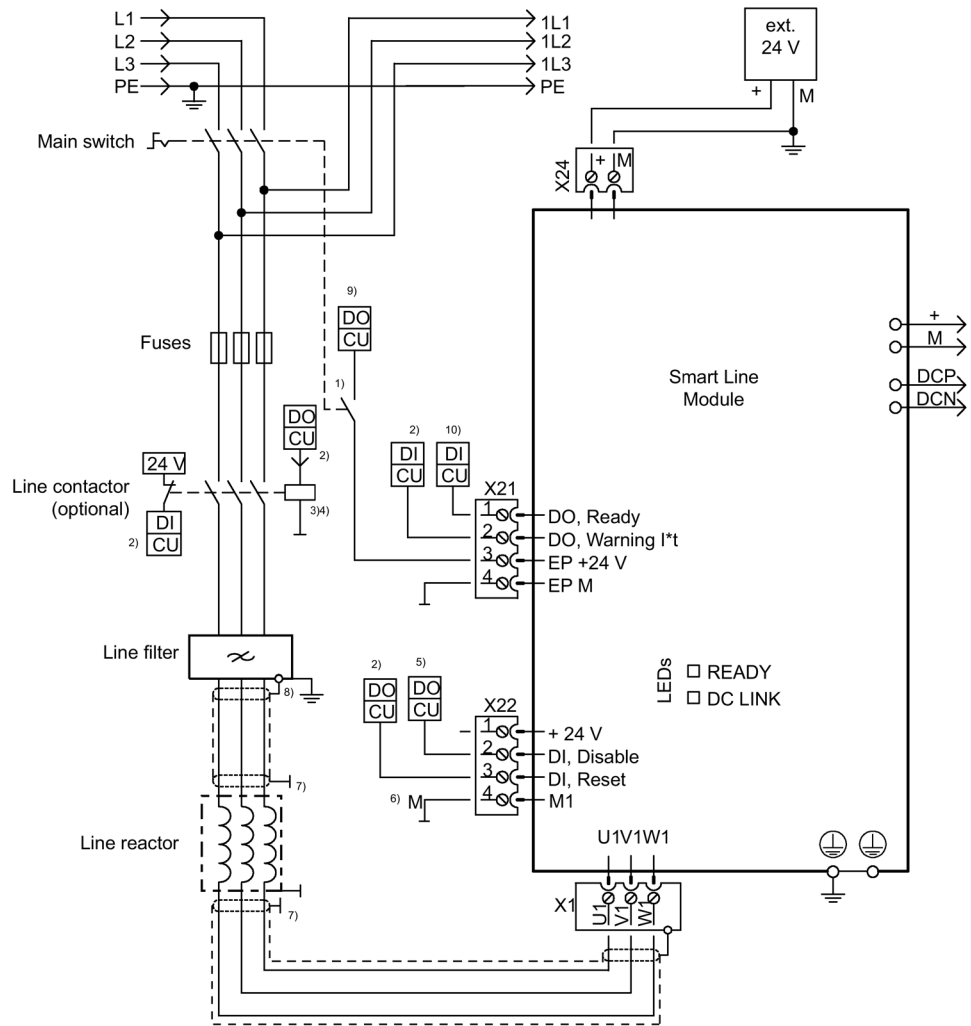

- 1) Leading opening contact $t > 10$ ms; 24 V DC and ground must be connected for operation.
- 2) DI/DO, controlled by the Control Unit
- 3) No additional load permitted downstream of the line contactor
- 4) The current carrying capacity of the DO must be observed; an output coupling device may have to be used.
- 5) DO high, feedback deactivated (a bridge can be installed between X22 pin 1 and 2 for permanent deactivation)
- 6) X22 pin 4 must be connected with ground (ext. 24 V)
- 7) Contact established through the rear mounting panel or shield rails in accordance with the EMC installation guideline
- 8) 5 kW and 10 kW line filter via shield connection
- 9) Signal output of controller to prevent reaction of 24 V DC supply on EP terminal
- 10) Interconnection via BiCo to parameter p0864

Figure 4-77 Connection example for 5 kW and 10 kW Smart Line Modules

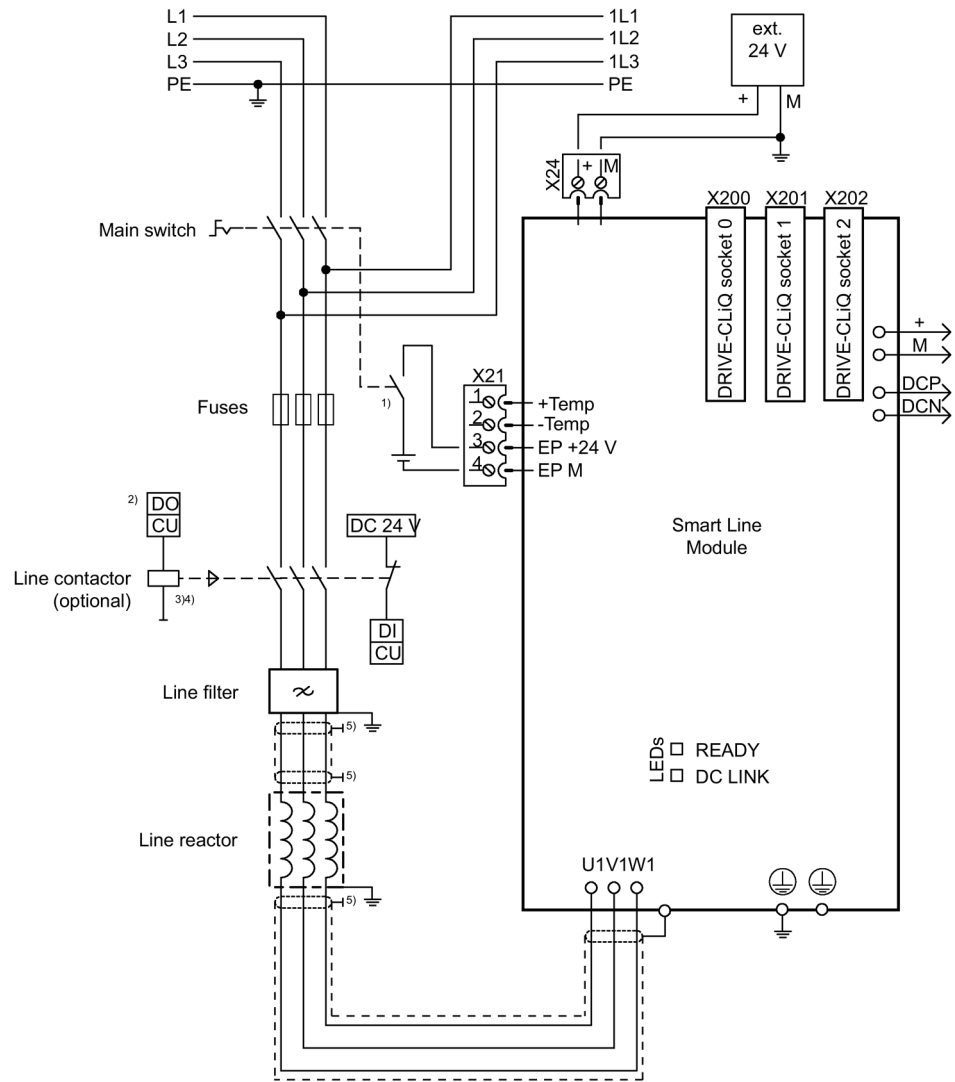

- 1) Leading opening contact, $t > 10$ ms
- 2) DI/DO, controlled from the Control Unit
- 3) No additional load/consumer is permitted after the line contactor
- 4) The current carrying capacity of the DO must be observed; an output coupling device may have to be used.
- 5) Contact established through the rear mounting panel or shield rails in accordance with the EMC installation guideline

Figure 4-78 Connection example for 16 kW to 55 kW Smart Line Modules

Note

If you are using a VSM10 Voltage Sensing Module, the leading opening contact can be omitted.

4.10.6 Meaning of LEDs

4.10.6.1 Smart Line Modules 5 kW and 10 kW

Table 4- 82 Meaning of the LEDs on 5 kW and 10 kW Smart Line Modules

LED	Color	Status	Description, cause	Remedy
RDY	–	Off	The electronics power supply is missing or outside the permissible tolerance range.	–
	Green	Continuous light	The component is ready for operation.	–
	Orange	Continuous light	The precharging has not yet been completed. The bypass relay has dropped out. The EP terminals are not supplied with 24 V DC.	–
	Red	Continuous light	Overtemperature overcurrent	Diagnose the fault (using the output terminals) and acknowledge (using the input terminal).
DC LINK	Orange	Continuous light	The DC link voltage is within permissible tolerance range.	–
	Red	Continuous light	The DC link voltage is outside the permissible tolerance range or a line fault is present.	Check the line supply voltage.

4.10.6.2 16 kW to 55 kW Smart Line Modules

Table 4- 83 Meaning of the LEDs on Smart Line Modules \geq 16 kW

Status		Description, cause	Remedy
RDY	DC LINK		
Off	Off	The electronics power supply is missing or outside the permissible tolerance range.	–
Green	-- ¹⁾	The component is ready for operation. Cyclic DRIVE-CLiQ communication is taking place.	–
	Orange	The component is ready for operation. Cyclic DRIVE-CLiQ communication is taking place. The DC link voltage is present.	–
	Red	The component is ready for operation. Cyclic DRIVE-CLiQ communication is taking place. The DC link voltage is outside the permissible tolerance range.	Check the line supply voltage.
Orange	Orange	DRIVE-CLiQ communication is being established.	–
Red	-- ¹⁾	This component has at least one fault.	Resolve and acknowledge the fault.
Green/red (0.5 Hz)	-- ¹⁾	Firmware is being downloaded.	–

Status		Description, cause	Remedy
RDY	DC LINK		
Green/red (2 Hz)	-- ¹⁾	Firmware download has been completed. The system waits for POWER ON.	Carry out a POWER ON.
Green/orange or red/orange	-- ¹⁾	Component recognition via LED is activated ²⁾ . Note: Both options depend on the LED status when component recognition is activated.	–

1) Irrespective of the status of the LED "DC LINK"

2) For information about activating the parameter "Recognition via LED", see SINAMICS S120/S150 List Manual

4.10.7 Dimension drawings

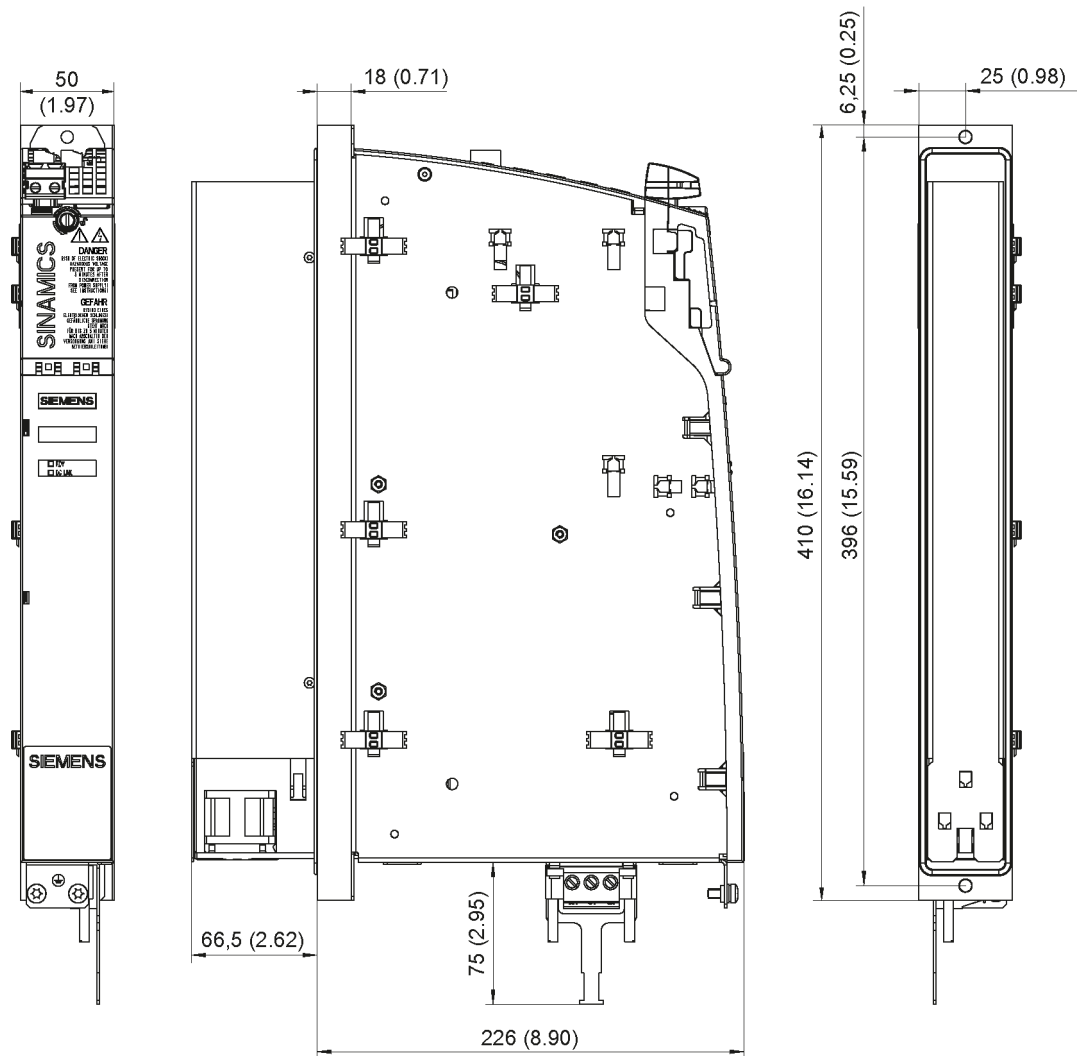

Figure 4-79 Dimension drawing of 5 kW and 10 kW Smart Line Modules with external air cooling, all dimensions in mm and (inches)

Note

The shield connecting plate is integrated in the power supply connector of the 50 mm Smart Line Modules.

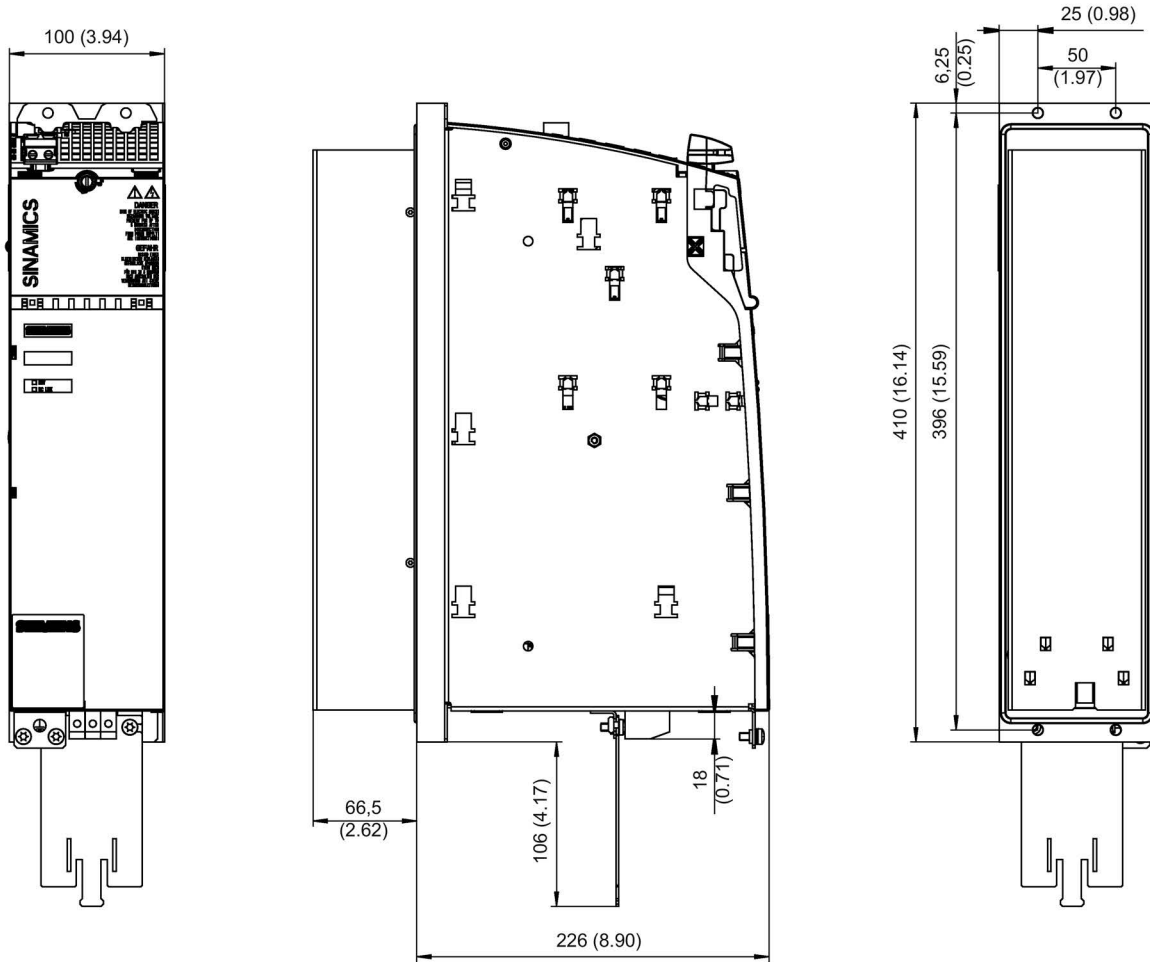

Figure 4-80 Dimension drawing of 16 kW Smart Line Module with external air cooling, all dimensions in mm and (inches)

Note

The shield connecting plate is part of the scope of delivery of the 100 mm Smart Line Modules.

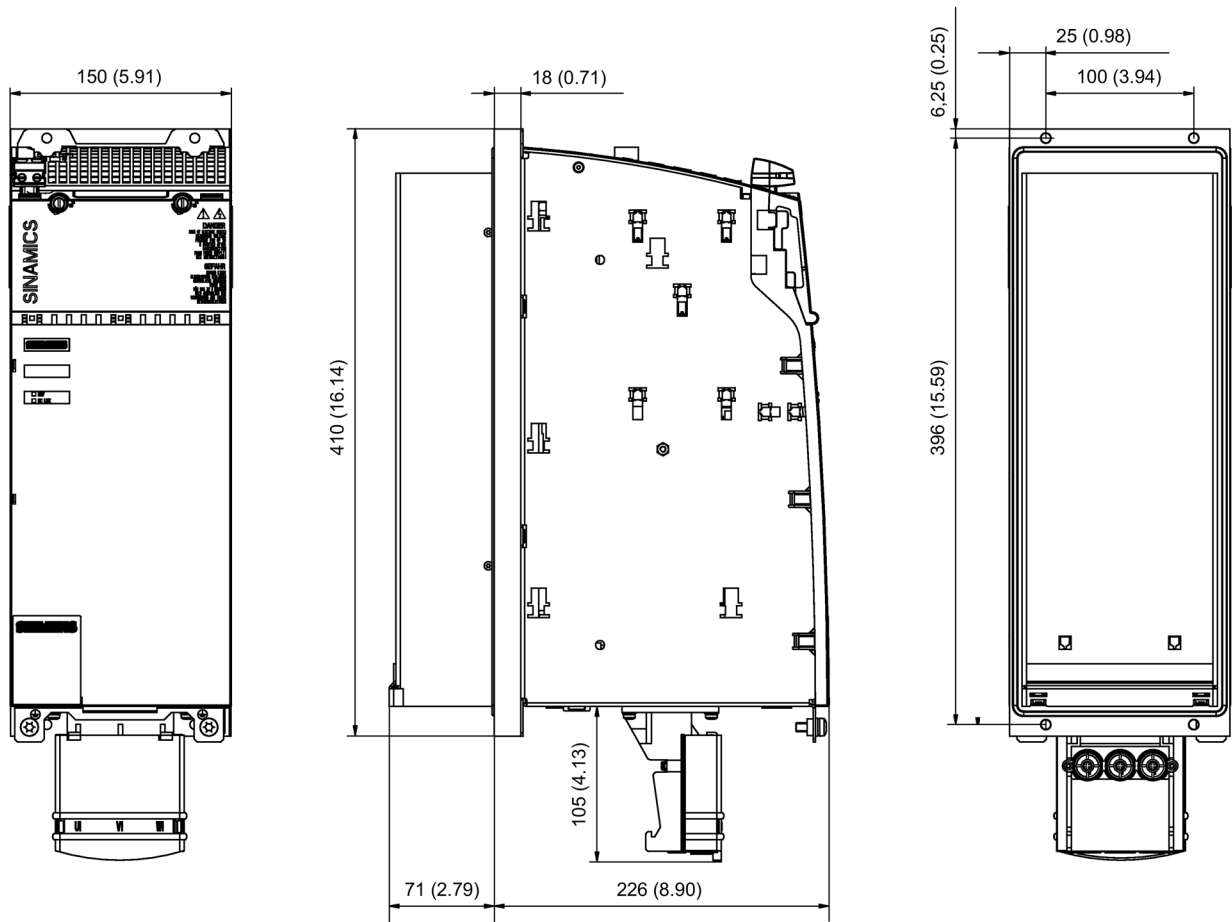

Figure 4-81 Dimension drawing of 36 kW Smart Line Module with external air cooling, all dimensions in mm and (inches)

4.10 Smart Line Modules with external air cooling

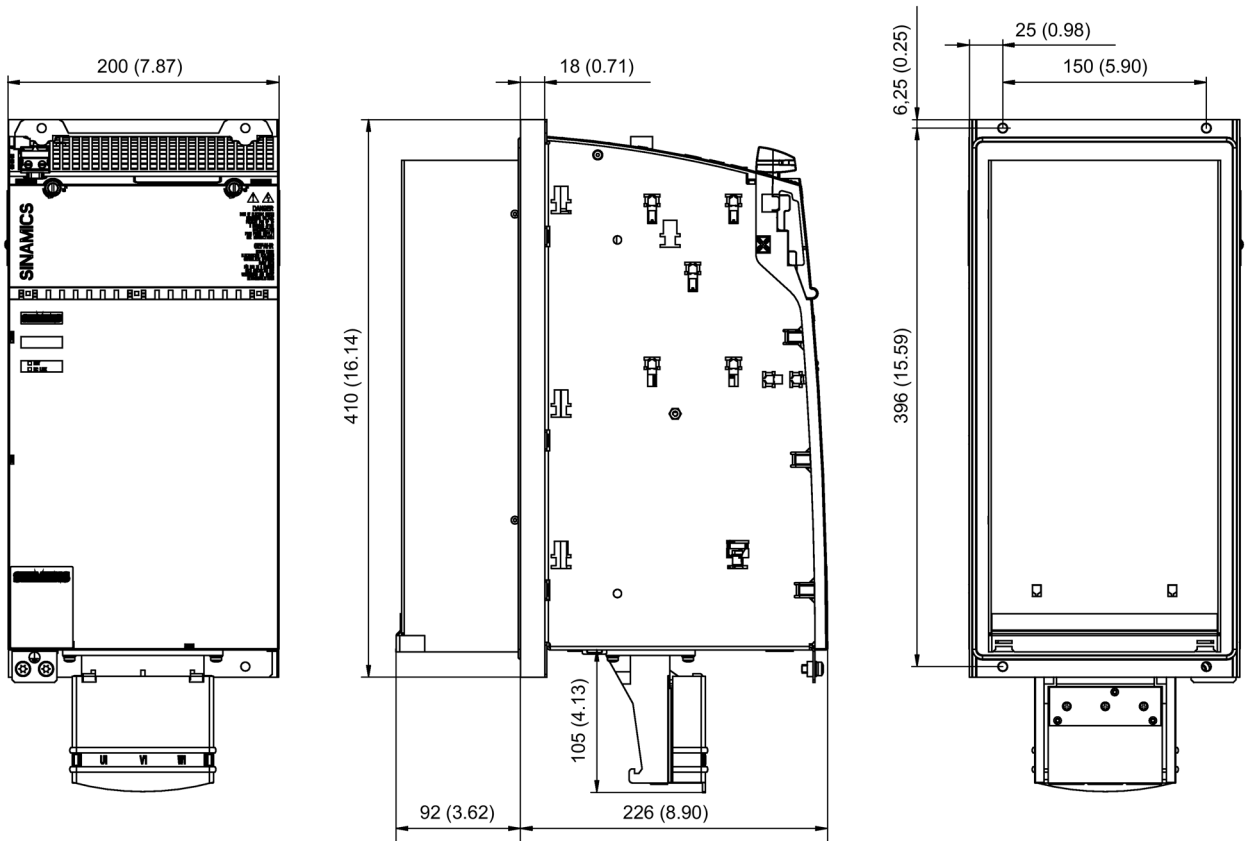
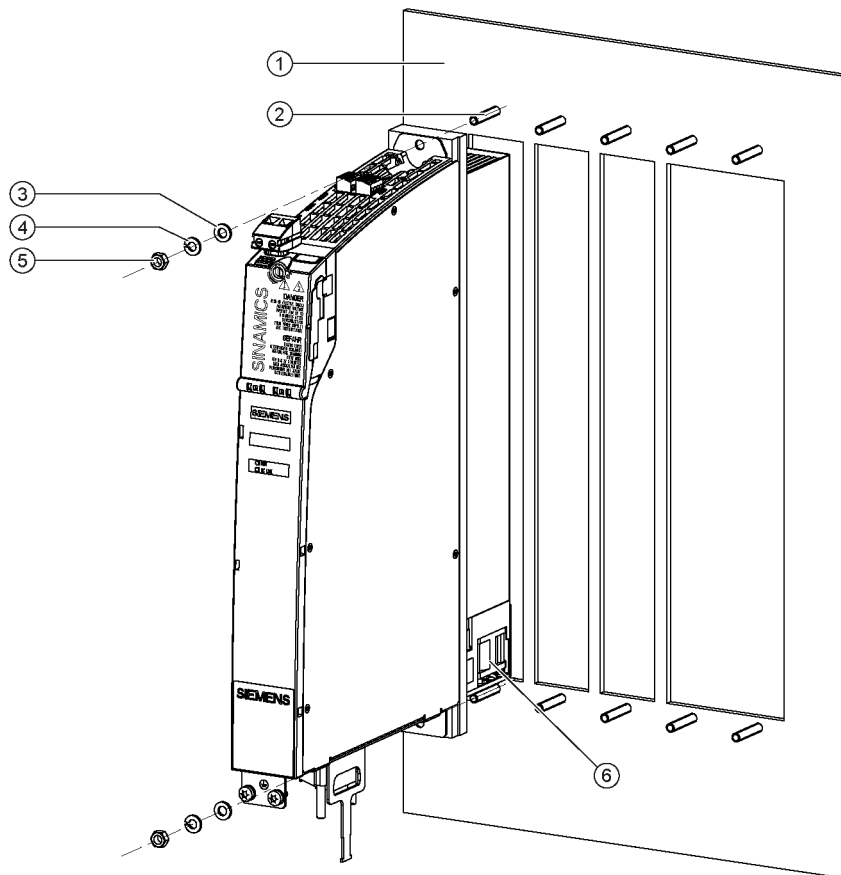

Figure 4-82 Dimension drawing of 55 kW Smart Line Module with external air cooling, all dimensions in mm and (inches)

4.10.8 Mounting



- ① Mounting plate with openings
- ② Threaded bolts M6
- ③ Washer
- ④ Spring washer
- ⑤ M6 nut, width A/F 10 (hexagon head)
- ⑥ Fan assembly

Figure 4-83 Mounting a Smart Line Module with external air cooling on a mounting plate, using a 5 kW Smart Line Module as an example

Tightening torques:

1. Firstly, tighten the nuts by hand.
Tightening torque: 0.5 Nm (4.4 lbf in)
2. Then tighten the nuts.
Tightening torque: 6 Nm (53.1 lbf in)

4.10 Smart Line Modules with external air cooling

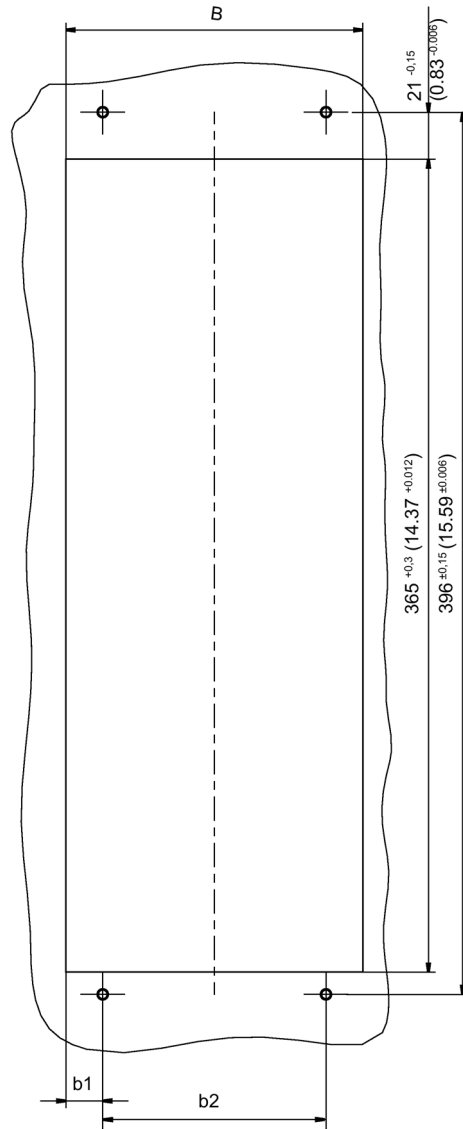

Figure 4-84 Opening to mount Smart Line Modules 50 mm to 200 mm with external air cooling, all data in mm and (inches)

Table 4- 84 Dimensions of openings to mount Smart Line Modules with external air cooling

Module width	W in mm (inch)	b1 in mm (inch)	b2 in mm (inch)
50 mm	41.5 +0.3 (1.63 +0.012)	20.75 +0.15 (0.82 +0.006)	--
100 mm	89.5 +0.3 (3.52 +0.012)	19.75 +0.15 (0.78 +0.006)	50 ±0.15 (1.97 ±0.006)
150 mm	133 +0.3 (5.24 +0.012)	16.5 +0.15 (0.65 +0.006)	100 ±0.15 (3.94 ±0.006)
200 mm	173 +0.3 (6.81 +0.012)	11.5 +0.15 (0.45 +0.006)	150 ±0.15 (5.91 ±0.006)

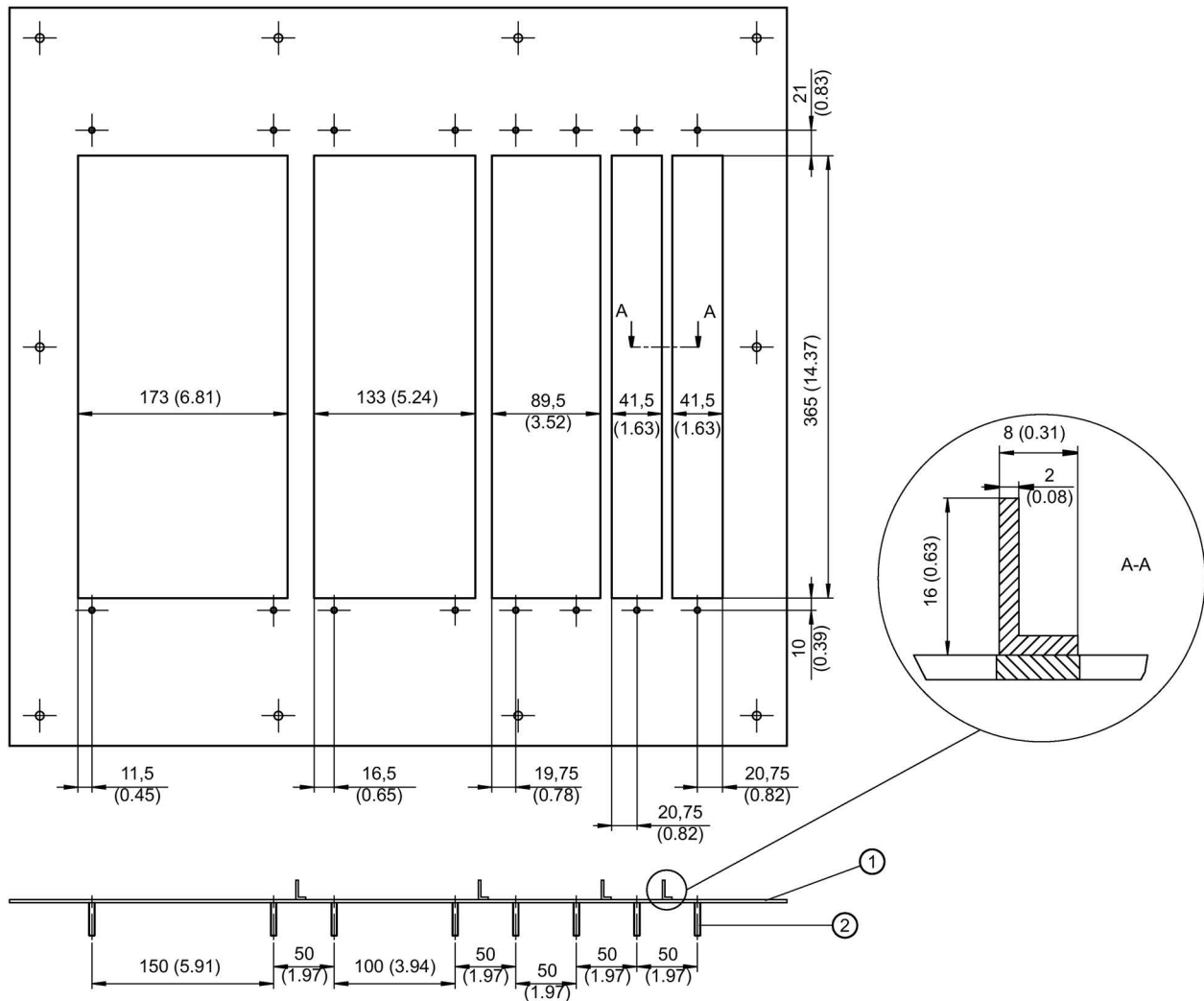
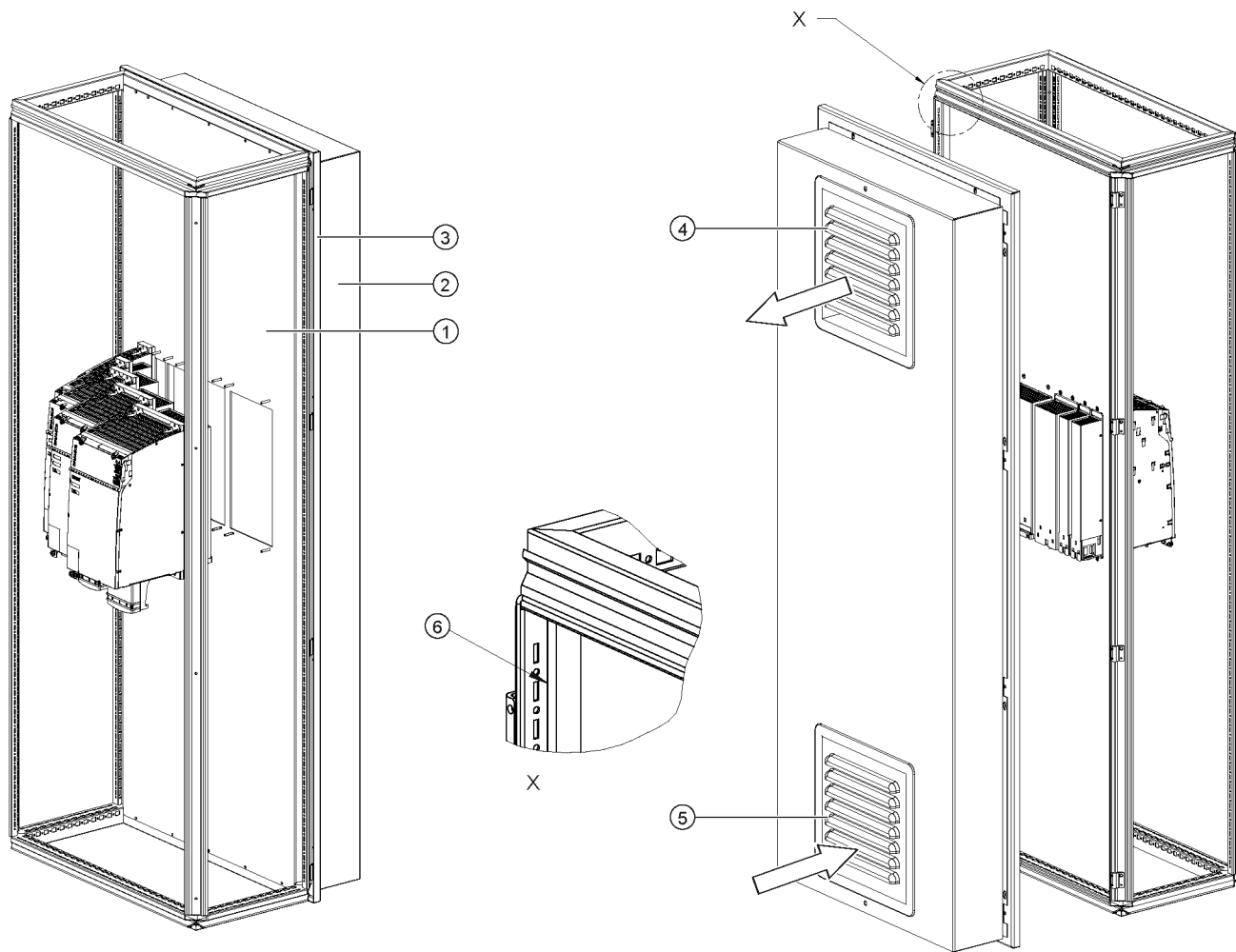

Figure 4-85 Example of a mounting plate for a drive line-up with external air cooling

When mounting it must be ensured that the component's seal is tight throughout. The cross-pieces must have the appropriate stability. If necessary, the cross-pieces of the openings must be reinforced.

In the example, the cross-pieces have been reinforced using brackets according to EN 755-9. You are free to select the way that the bracket is attached to the insert.



- ① Mounting plate
- ② Cover
- ③ Rear panel
- ④ Air discharge
- ⑤ Air inlet - filter with filter fan
- ⑥ To comply with degree of protection IP54, the surfaces ⑥ between the mounting plate and the cabinet strip must be sealed all round (e.g. Terostat-91 sealant from Teroson).

Figure 4-86 Example 1: mounting in the cabinet with mounting plate

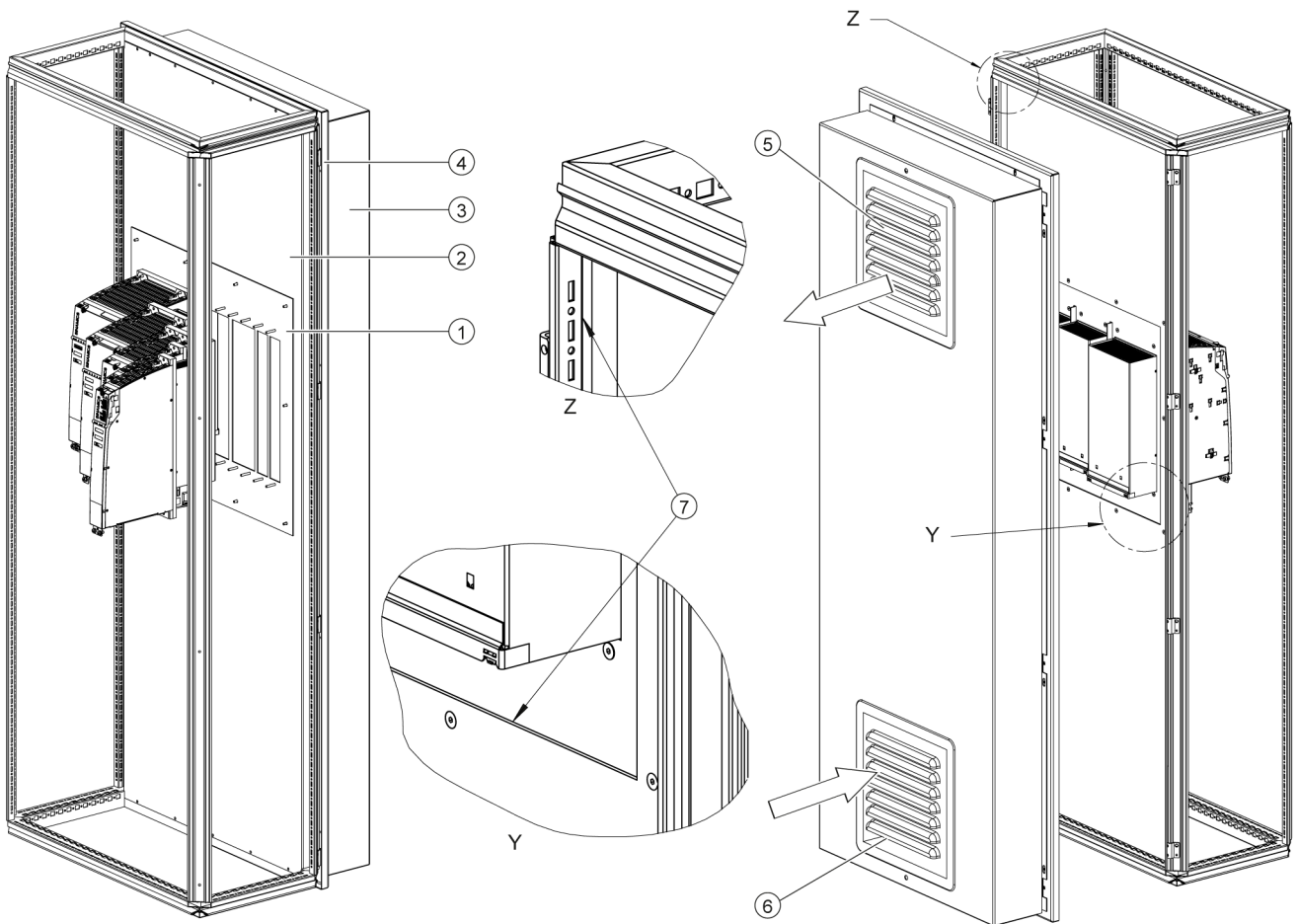

- ① Insert plate
- ② Mounting plate
- ③ Cover
- ④ Rear panel
- ⑤ Air discharge
- ⑥ Air inlet - filter with filter fan
- ⑦ To comply with degree of protection IP54, the surfaces ⑦ between the mounting plate and the cabinet strip and between the mounting plate and the insert plate must be sealed all round (e.g. Terostat-91 sealant from Teroson).

Figure 4-87 Example 2: mounting in the cabinet with mounting plate

It is recommended that you attach a cover and filter fan to the cabinet.

4.10 Smart Line Modules with external air cooling

The filtered fan must be fitted in such a way that the cooling air required by the drive line-up is not restricted. The overall cooling air requirement is obtained from the sum of the individual components (see Section "Technical data (Page 294)").

Note

If the cooling air requirement is not covered by the filtered fan, the components cannot output their specified power.

The filters with filter fan must be regularly checked for dirt and cleaned if necessary.

Help with the mechanical control cabinet design is available from:

Siemens AG
 Digital Factory, DF MC MF - WKC AS
 TCCCC (Technical Competence Center Cabinets Chemnitz)
 Postfach 1124
 09070 Chemnitz
 E-mail: cc.cabinetcooling.aud@siemens.com

4.10.9 Technical data

Table 4- 85 Technical data Smart Line Modules Booksize external air cooling

Internal air cooling	6SL3131-	6AE15-0AA.	6AE21-0AA.	6TE21-6AA.	6TE23-6AA.	6TE25-5AA.
Rated power	kW	5	10	16	36	55
Infeed¹⁾						
Rated power S1 duty	kW (P _n)	5	10	16	36	55
Infeed power S6 duty (40 %)	kW (P _{S6})	6.5	13	21	47	71
Peak infeed power	kW (P _{max})	10	20	35	70	91
Regenerative feedback						
Continuous regenerative power	kW	5	10	16	36	55
Peak regenerative power	kW	10	20	35	70	91
Supply voltages		3 AC 380 ... 480 ± 10 % (-15 % < 1 min)				
Line voltage	V _{AC}	47 ... 63				
Line frequency	Hz	24 (20.4 ... 28.8)				
Electronics power supply	V _{DC}	510 ... 720				
DC-link voltage	V _{DC}	820 ± 2 %				
Overvoltage trip	V _{DC}	360 ± 2 %				
Undervoltage trip ²⁾	V _{DC}					
Input currents						
Rated input current at AC 400 V	A _{AC}	8.1	16.2	27.5	59	90
at AC 380 V / AC 480 V	A _{AC}	8.6 / 6.7	17 / 12.8	29 / 24.5	62 / 51	94 / 77
S6 duty (40 %) at AC 400 V	A _{AC}	10.6	21.1	35	76	106
Peak current at AC 400 V	A _{AC}	15.7	31.2	57.5	112	130

Internal air cooling	6SL3131-	6AE15-0AA.	6AE21-0AA.	6TE21-6AA.	6TE23-6AA.	6TE25-5AA.
Rated power	kW	5	10	16	36	55
DC-link currents						
DC-link output current at 600 V DC	A _{DC}	8.3	16.6	27	60	92
at 510 V DC / 720 V DC	A _{DC}	9.3 / 6.9	19.6 / 13.9	30 / 22.2	67 / 50	92 / 76.4
S6 duty (40%) at 600 V DC	A _{DC}	11	22	35	79	138
Peak current at 600 V DC	A _{DC}	16.6	33.2	59	118	178
Current carrying capacity						
DC link busbars	A _{DC}	100	100	100	200	200
Reinforced DC link busbars	A _{DC}	150	150	150	--	--
24 V DC busbars	A _{DC}	20	20	20	20	20
Electronics current consumption at 24 V DC	A _{DC}	0.8	0.9	0.95	1.5	1.9
Total power loss (incl. electronics losses)	W	79.2	141.6	187.8	406	665.6
internal	W	41.2	66.6	64.8	116	185.6
external	W	38	75	123	290	480
(see power loss tables (Page 734))						
DC link capacitance						
Smart Line Module	μF	220	330	705	1410	1880
Drive line-up, max.	μF	6000	6000	20000	20000	20000
Power factor	cos φ	0.98	0.98	0.98	0.98	0.98
Circuit breaker (IEC 60947 and UL)		See Chapter Overcurrent protection using fuses and circuit breakers (Page 47)				
Max. total cable length³⁾		See Chapter Combination options, Line Modules with line reactors and line filters (Page 120)				
Sound pressure level	dB(A)	< 60	< 60	< 60	< 65	< 60
Cooling air requirement	m ³ /h	29.6	29.6	56	112	160
Max. permissible heat sink temperature	°C	69 ⁴⁾	73 ⁴⁾	77	80	75
Ventilation clearances above/below	mm	≥ 80				
Rated voltage for rated data 3 AC 380 V						
Weight	kg	5.3	5.4	8.8	14.0	20.5

1) The specified power ratings apply to the line voltage range from 380 V to 480 V.

2) For 16 kW and 36 kW Smart Line Modules: Default for 400 V line supplies; undervoltage trip threshold is adjusted to the parameterized rated voltage.

3) Maximum total cable length = Σ motor cables, line feeder cable from line filter to the Line Module

4) Values cannot be read out by the system (STARTER).

4.10.9.1 Characteristics

Rated duty cycles of Smart Line Modules

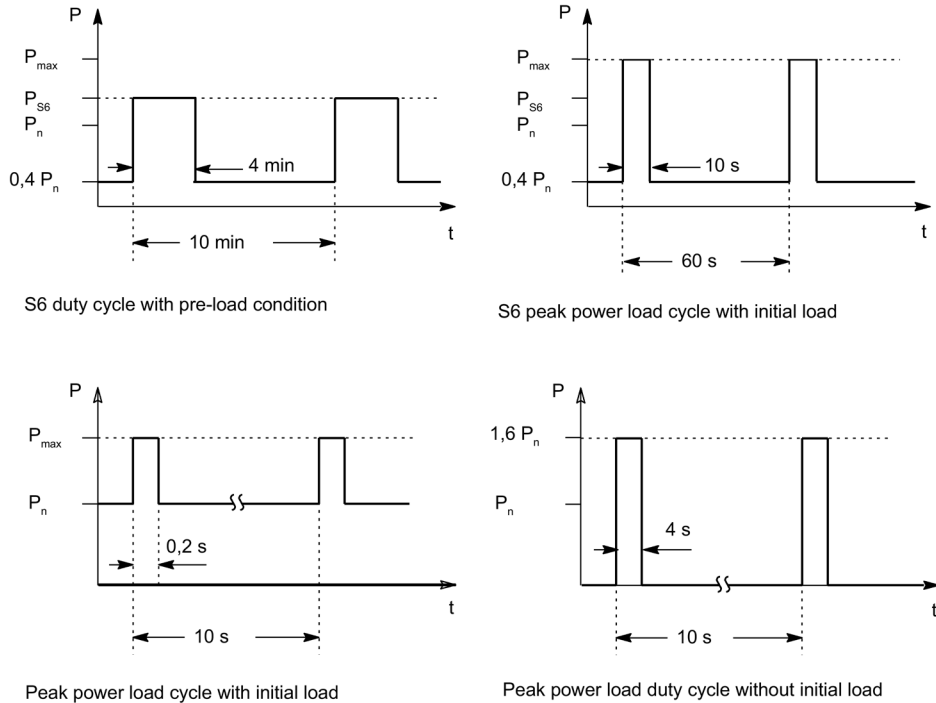

Figure 4-88 Rated duty cycles of Smart Line Modules

4.11 Smart Line Modules with cold plate

4.11.1 Description

The Smart Line Module is a non-regulated infeed/regenerative feedback unit. The Smart Line Module supplies the Motor Module with a non-regulated DC voltage at the DC output. In the infeed mode the Smart Line Module exhibits the typical current and voltage waveforms of a 6-pulse diode rectifier bridge.

In feedback mode, the current waveform is square waved. Feedback can be deactivated by means of a terminal because these Smart Line Modules are not equipped with a DRIVE-CLiQ connection.

The DC link starts precharging as soon as the line voltage is applied and is independent of its phase sequence direction. Load can be applied to the DC link after the module has been enabled.

A line contactor can be installed on the line side if the system has to be electrically isolated from the line supply.

Smart Line Modules are suitable for direct operation on TN, IT and TT systems. The Line Modules have an integrated overvoltage protection function.

4.11.2 Additional safety instructions for Smart Line Modules Booksize

NOTICE**Damage to the Smart Line Module for an incorrect switch-on or switch-off sequence**

It is essential that an appropriate switch-on and switch-off sequence (Page 298) is complied with in order to control the 5 kW and 10 kW Smart Line Modules; if this sequence is not observed, the Smart Line Module could be damaged beyond repair.

- Comply with the specified switching sequence.

Note**Connected to the public low-voltage network**

Smart Line Modules have been designed for use in the industrial environment and generate current harmonics on the line side as a result of the rectifier circuit.

When connecting a machine with integrated Smart Line Modules to the public low-voltage line supply (grid), authorization is required in advance from the local power supply company (utility company) in the following cases:

- The rated current of the motor ≤ 16 A per conductor.
- The rated motor current does not comply with the requirements specified in EN 61000-3-2 regarding current harmonics.

4.11.3 Switch-on/switch-off sequence for 5 kW and 10 kW Smart Line Modules

It is essential that the subsequently described switch-on and switch-off sequence is complied with in order to control the 5 kW and 10 kW Smart Line Modules; if this sequence is not observed, the Smart Line Module could be destroyed.

Observe the "Ready" signal at output terminal X21.1:

Switching on

1. 24 V DC supply X24 ON
2. Line contactor ON
3. EP signal X21.3 and X21.4 ON
4. Wait until precharging has been completed
5. "Ready" signal at terminal X21.1 switched to high
6. Infeed is ready, pulse enable possible for motors

Switching off

1. Shut drives down
2. Cancel pulse enable for motors (OFF1 signal)
3. EP signal X21.3 and X21.4 OFF
4. Line contactor OFF
5. 24 V DC supply X24 OFF

Overload

1. "Prewarning" signal at terminal X21.2 switches to low
2. Shut drives down via the control system
3. "Ready" signal at terminal X21.1 switches to low
4. Pulse inhibit for all the drives supplied by this infeed within 4 ms

4.11.4 Interface description

4.11.4.1 Overview

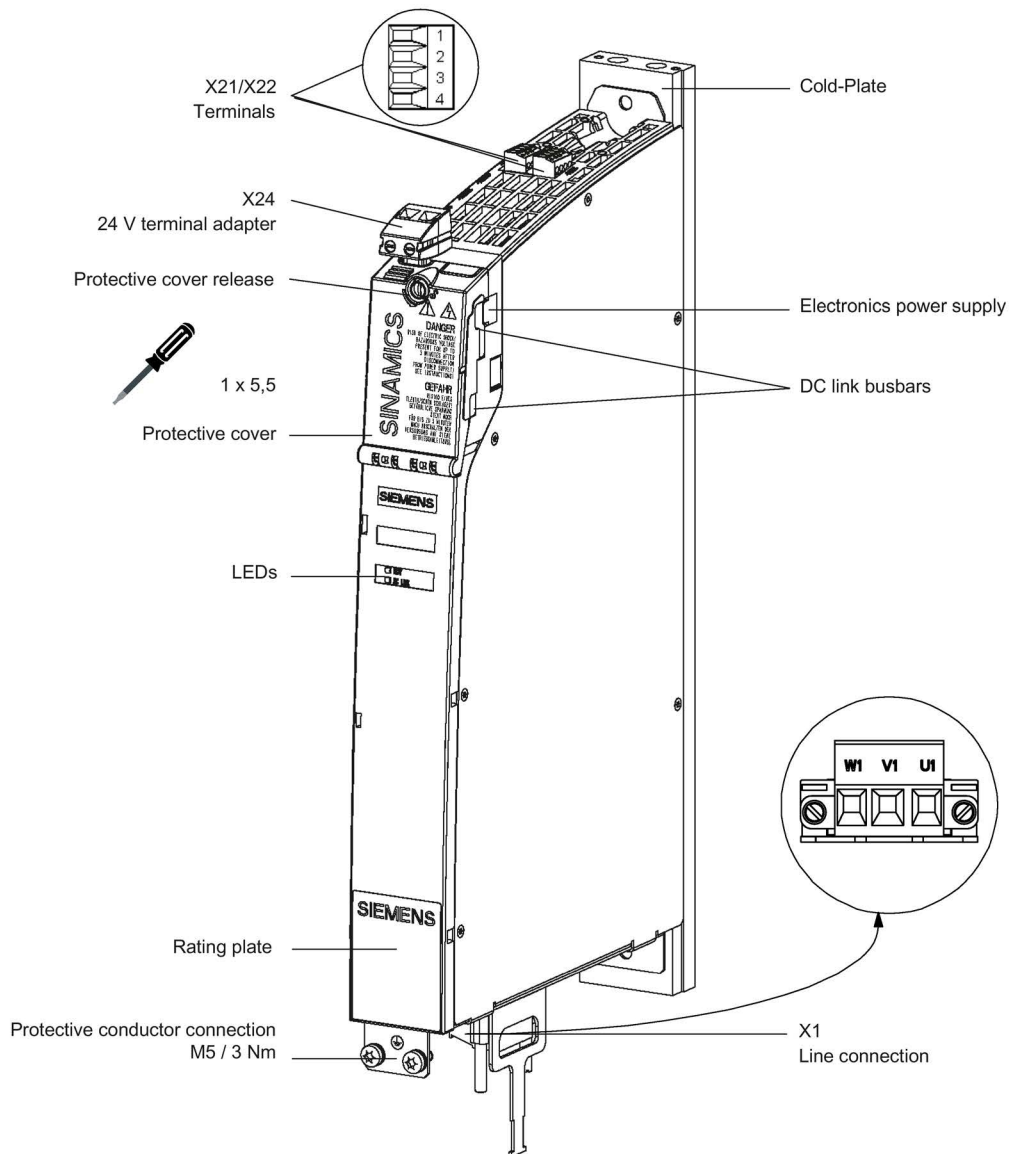
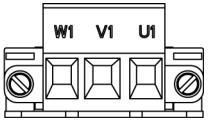
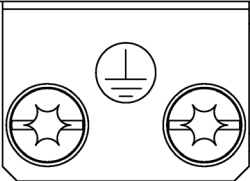

Figure 4-89 Interface overview, Smart Line Module with cold plate (example: 5 kW)

4.11 Smart Line Modules with cold plate

4.11.4.2 X1 line connection

Table 4- 86 X1 line connection

	Terminal	Technical data
	U1	Supply voltage: 3 AC 380 ... 480 V, 50 / 60 Hz Type: Screw terminal 5 (Page 708)
	V1	
	W1	
	Protective conductor connection	Threaded hole M5 / 3 Nm (26.6 lbf in) ¹⁾
¹⁾ For ring cable lugs without insulation (Page 710)		

4.11.4.3 X21 EP terminals

Table 4- 87 X21 EP terminals

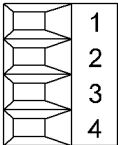
	Terminal	Designation	Technical data
	1	DO: Ready	Feedback signal: Smart Line Module ready The signal switches to high level when the following conditions have been met: <ul style="list-style-type: none"> • Electronics power supply (X24) OK • DC link is precharged • Pulses enabled (X21.3/.4) • No overtemperature • No overcurrent switch-off
	2	DO: Prewarning	DO: Prewarning High = no prewarning Low = prewarning <ul style="list-style-type: none"> • Overtemperature warning threshold / I*t 5 kW prewarning: 64° C, disconnection: 69° C 10 kW prewarning: 68° C, disconnection: 73 °C • No regenerative feedback capability due to a line fault [only monitored when feedback is activated (see terminal X22.2)]
	3	EP +24 V (pulse enable)	Voltage: 24 V DC (20.4 ... 28.8 V) Current consumption, typical: 4 mA at 24 V Isolated input
	4	EP M (Enable Pulses)	
Type: Screw terminal 1 (Page 708)			

Terminals X21.1 and X21.2

Note

Wiring to a digital input of the Control Unit

Output terminal X21.1 must be wired to a digital input on the CU. The drives supplied with power from the Smart Line Module have to use this signal as a ready signal. This ensures that a pulse enable can only be issued for the drives (motor or generator operation) when the infeed is ready.

If interconnection with a digital input on the CU is not possible, the signal must be evaluated by a higher-level control system instead. It is not permissible that the control system sets the drives to ready until the infeed "Ready" signal is present.

Note

Evaluating the "Prewarning" signal

The "Prewarning" signal at output terminal X21.2 warns against an overload. If this signal is set to low, the control system shuts the drives down before the "Ready" signal switches to low. If the "Ready" signal switches to "low", the drive pulses must be suppressed within 4 ms.

Note

The Smart Line Module signals "Ready" (X21.1 = "High"), even if one of the line conductor voltages is not available. In this case, regenerative feedback is deactivated and an alarm is output at X21.2 (DO, Warning I²t low signal).

If regenerative feedback was deactivated by applying a "high" signal to terminal X22.2 (DI, Disable), no alarm will be output at X21.2 (DO, Warning I²t).

Terminals X21.3 and X21.4

For operation, the 24 V DC voltage must be connected to terminal X21.3 and ground to terminal X21.4.

Pulse cancellation is activated if the power supply is disconnected. As a consequence, regenerative feedback is deactivated and the bypass relay drops out. If the Line Module is not disconnected from the line supply when the EP terminal is de-energized, for example, because a line contactor is not installed, then the DC link remains charged.

4.11 Smart Line Modules with cold plate

4.11.4.4 X22 digital inputs

Table 4- 88 X22 digital inputs for Smart Line Modules 5 kW and 10 kW

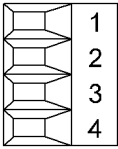
	Terminal	Designation ¹⁾	Technical data
	1	24 V power supply	Electronics power supply for controlling digital inputs X22.2 and 3
	2	DI: Disable Regeneration	Deactivate regenerative feedback (high active) No power is supplied back to the network from the DC link. The regenerative energy of the motors may have to be reduced using a combination of the Braking Module and braking resistor.
	3	DI: Reset	Reset faults (negative edge)
	4	Ground	Electronics ground
Type: Screw terminal 1 (Page 708)			

¹⁾ DI: Digital input

4.11.4.5 X24 24 V terminal adapter

Table 4- 89 X24: 24 V terminal adapter

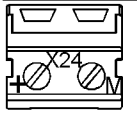
	Terminal	Designation	Technical data
	+	24 V power supply	24 V DC supply voltage
	M	Ground	Electronics ground
Type: Screw terminal 5 (Page 708)			

The 24 V terminal adapter is included in the scope of supply.

4.11.5 Connection example

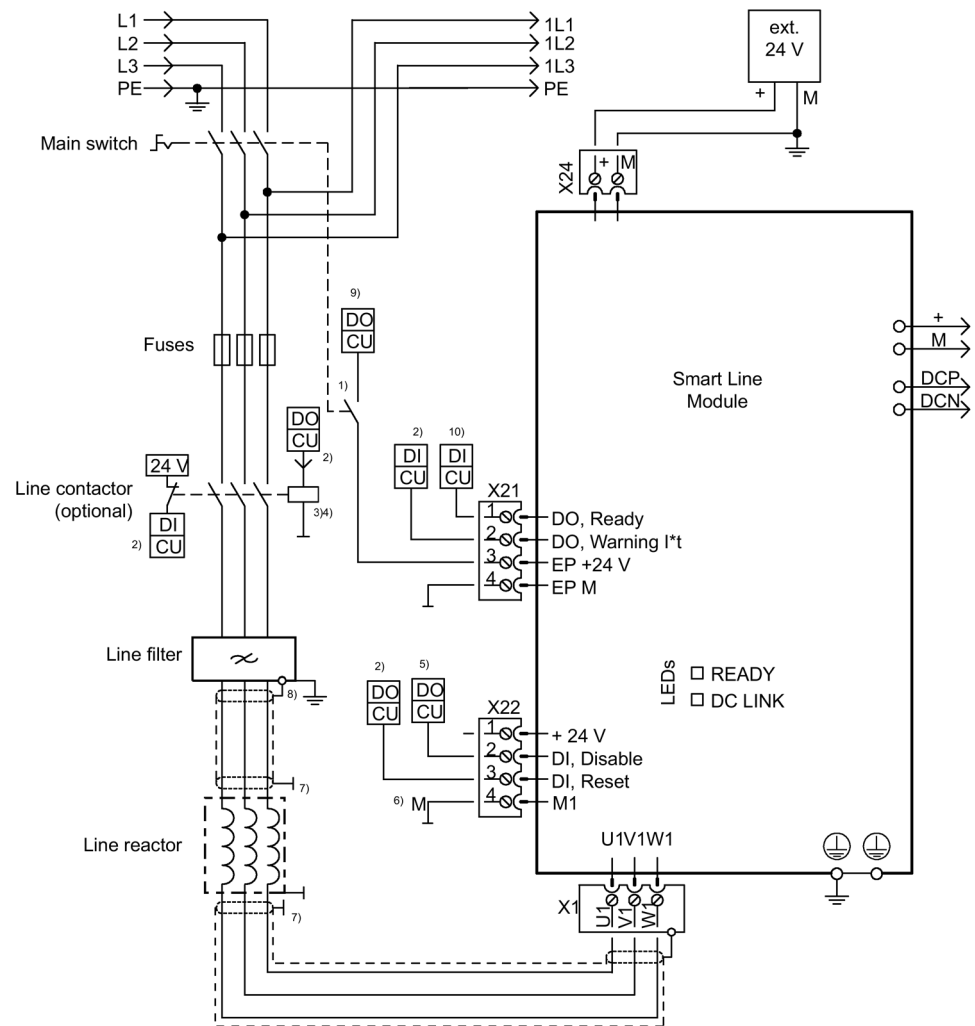

- 1) Leading opening contact $t > 10$ ms; 24 V DC and ground must be connected for operation.
- 2) DI/DO, controlled by the Control Unit
- 3) No additional load permitted downstream of the line contactor
- 4) The current carrying capacity of the DO must be observed; an output coupling device may have to be used.
- 5) DO high, feedback deactivated (a bridge can be installed between X22 pin 1 and 2 for permanent deactivation)
- 6) X22 pin 4 must be connected with ground (ext. 24 V)
- 7) Contact established through the rear mounting panel or shield rails in accordance with the EMC installation guideline
- 8) 5 kW and 10 kW line filter via shield connection
- 9) Signal output of controller to prevent reaction of 24 V DC supply on EP terminal
- 10) Interconnection via BiCo to parameter p0864

Figure 4-90 Connection example for 5 kW and 10 kW Smart Line Modules

4.11.6 Meaning of LEDs

Table 4- 90 Meaning of the LEDs on 5 kW and 10 kW Smart Line Modules

LED	Color	Status	Description, cause	Remedy
RDY	–	Off	The electronics power supply is missing or outside the permissible tolerance range.	–
	Green	Continuous light	The component is ready for operation.	–
	Orange	Continuous light	The precharging has not yet been completed. The bypass relay has dropped out. The EP terminals are not supplied with 24 V DC.	–
	Red	Continuous light	Overtemperature overcurrent	Diagnose the fault (using the output terminals) and acknowledge (using the input terminal).
DC LINK	Orange	Continuous light	The DC link voltage is within permissible tolerance range.	–
	Red	Continuous light	The DC link voltage is outside the permissible tolerance range or a line fault is present.	Check the line supply voltage.

4.11.7 Dimension drawings

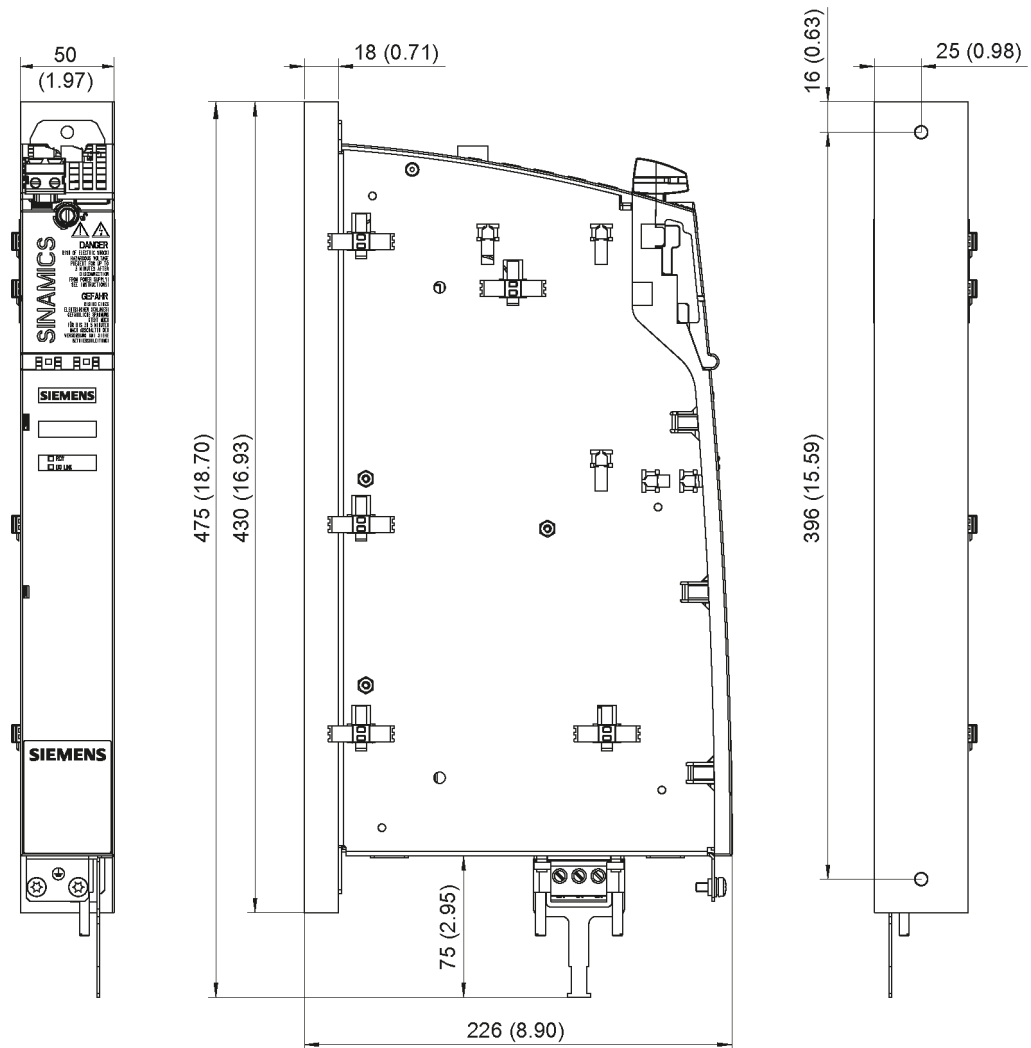

Figure 4-91 Dimension drawing of Smart Line Module with cold plate (5 kW and 10 kW), all dimensions in mm and (inches)

Note

The shield connecting plate is integrated in the power supply connector of the 50 mm Smart Line Modules.

4.11.8 Mounting

Please note the following before mounting a Smart Line Module with cold plate on a customer-specific heat sink:

- Before mounting, check the surface of the heat sink to ensure that it is not damaged.
- To improve heat transfer, a heat-conducting medium must be used. Special spherical-indented heat-conducting foil must be used for this purpose. Every cold plate power unit is supplied with heat-conducting foil cut to the right size. Note the mounting position of the heat-conducting foil (see figures below).

Note

Use heat conducting foil

- Also replace the heat-conducting foil when replacing a component.
- Only use heat-conducting foil released or supplied by Siemens.

	Article No.
Heat-conducting foil, 50 mm	6SL3162-6FB00-0AA0

Note

To mount the components, M6 threaded bolts and hexagon nuts/grub screws ISO 7436-M6x40-14 H, property class 8.8 are recommended.

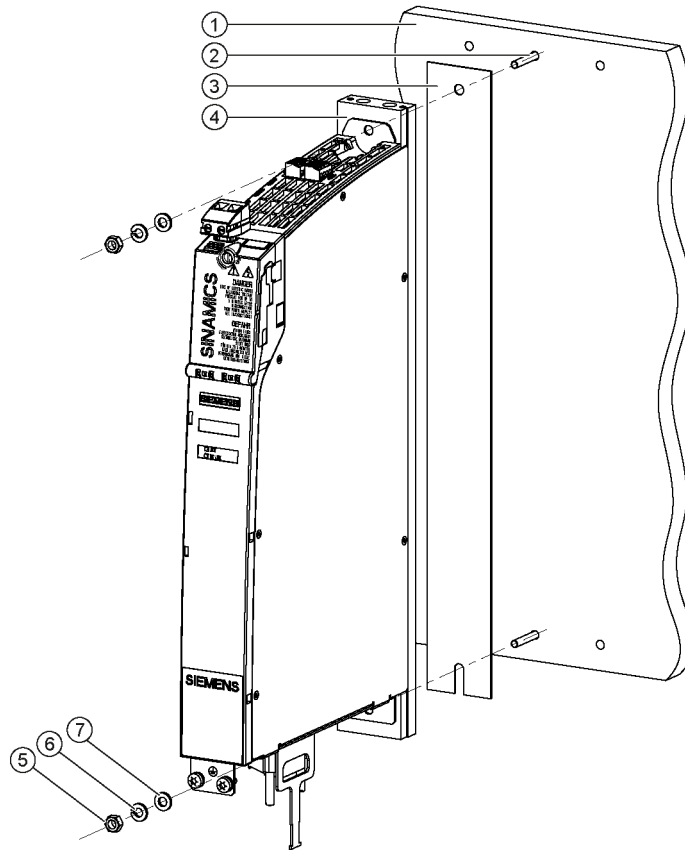

- ① External heat sink (air or liquid)
- ② Threaded bolts M6
- ③ Heat-conducting foil
- ④ Cold plate
- ⑤ M6 nut
- ⑥ Spring washer
- ⑦ Washer

Figure 4-92 Mounting a Smart Line Module with cold plate on an external heat sink, using a 5 kW Smart Line Module as an example

Tightening torques:

1. Firstly, only tighten the nuts by hand.
Tightening torque: 0.5 Nm (4.4 lbf in)
2. Then tighten the nuts.
Tightening torque: 10 Nm (88.5 lbf in)

4.11 Smart Line Modules with cold plate

Help with the mechanical control cabinet design is available from:

Siemens AG
 Digital Factory, DF MC MF - WKC AS
 TCCCC (Technical Competence Center Cabinets Chemnitz)
 Postfach 1124
 09070 Chemnitz
 e mail: cc.cabinetcooling.aud@siemens.com

Properties of the heat sink

We recommend using AlMgSi 0.5 as the heat sink material.
 The roughness of the external heat sink surface should be at least Rz 16 and the contact surface between the heat sink and cold plate should have an evenness of 0.2 mm.

Note

Machine manufacturers can adapt the heat sink version to their special requirements. The specified rated data for the Power Modules can only be achieved if the power losses can be dissipated by the external heat sink under the specified general conditions.

NOTICE
Damage to the cold plate caused by incorrect mounting
The threaded bolts can damage the cold plate when it is being mounted.
<ul style="list-style-type: none"> Do not damage the cold plate.

4.11.9 Technical data

Table 4- 91 Technical data for Smart Line Modules with cold plate cooling

	6SL3136-	6AE15-0AA.	6AE21-0AA.
Rated power	kW	5	10
Infeed¹⁾			
Rated power S1 duty	kW (P _n)	5	10
Infeed power S6 duty (40 %)	kW (P _{S6})	6.5	13
Peak infeed power	kW (P _{max})	10	20
Regenerative feedback			
Continuous regenerative power	kW	5	10
Peak regenerative power	kW	10	20
Supply voltages			
Line voltage	V _{AC}	3 AC 380 ... 480 ± 10 % (-15 % < 1 min)	
Line frequency	Hz	47 ... 63	
Electronics power supply	V _{DC}	24 (20.4 ... 28.8)	
DC-link voltage	V _{DC}	510 ... 720	
Overvoltage trip	V _{DC}	820 ± 2 %	
Undervoltage trip	V _{DC}	360 ± 2 %	

	6SL3136-	6AE15-0AA.	6AE21-0AA.
Input currents			
Rated input current at AC 400 V	A_{AC}	8.1	16.2
Input current at AC 380 V / AC 480 V	A_{AC}	8.6 / 6.7	17 / 12.8
at AC 400 V; S6 duty (40 %)	A_{AC}	10.6	21.1
at AC 400 V; peak current	A_{AC}	15.7	31.2
DC-link currents			
Rated DC-link current at 600 V DC	A_{DC}	8.3	16.6
DC-link current at 510 V DC / 720 V DC	A_{DC}	9.3 / 6.9	19.6 / 13.9
at 600 V DC; S6 duty (40%)	A_{DC}	11	22
at 600 V DC; peak current	A_{DC}	16.6	33.2
Current carrying capacity			
DC link busbars	A_{DC}	100	100
Reinforced DC link busbars	A_{DC}	150	150
24 V DC busbars	A_{DC}	20	20
Electronics current consumption at 24 V DC	A_{DC}	0.6	0.7
Power loss distribution (incl. electronics losses)	W	74.4	136.8
internal	W	34.4	56.8
external	W	40	80
(see power loss tables (Page 734))			
DC link capacitance			
Smart Line Module	μF	220	330
Drive line-up, max.	μF	6000	6000
Power factor	$\cos \varphi$	1	1
Circuit breaker (IEC 60947 and UL)		See Chapter Overcurrent protection using fuses and circuit breakers (Page 47)	
Max. total cable length²⁾		See Chapter Combination options, Line Modules with line reactors and line filters (Page 120)	
Max. permissible heat-sink temperature	$^{\circ}C$	60	65
Ventilation clearances above/below	mm	≥ 80	
Weight	kg	4.0	4.0

1) The specified power ratings apply to the line voltage range from 380 V to 480 V.

2) Maximum total cable length = Σ motor cables, line feeder cable from line filter to the Line Module

4.11.9.1 Characteristics

Rated duty cycles of Smart Line Modules

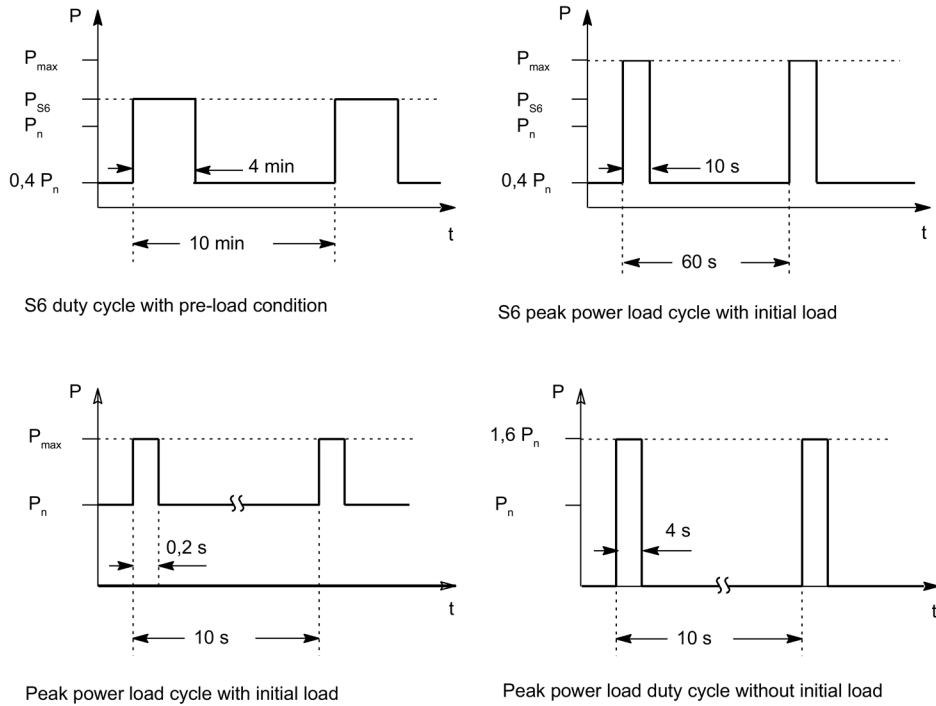

Figure 4-93 Rated duty cycles of Smart Line Modules

4.11.9.2 Measuring the heat sink temperature

The maximum permissible heat sink temperature is calculated at the cold plate in the measuring range shown below.

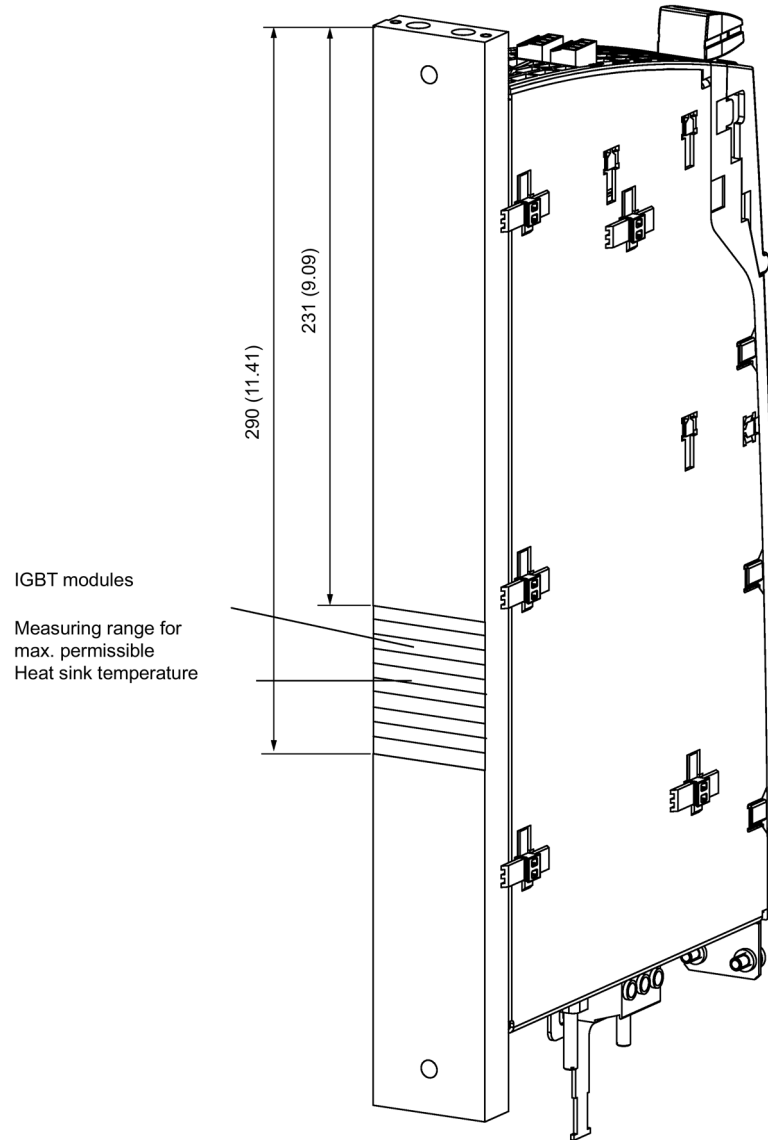

Figure 4-94 Measuring range for max. permissible heat-sink temperature for a Smart Line Module with cold plate

Line Modules Booksize Compact

5.1 Frequency with which the DC link is precharged

The frequency with which the DC link capacitance is precharged via the Line Module is determined using the following formula:

$$\text{Number of pre-charging operations within 8 minutes} = \frac{\text{Max. permissible DC link capacitance Line Module in } \mu\text{F}}{\Sigma\text{DC link capacitance of the configured drive line-up in } \mu\text{F}}$$

The DC link capacitances of the individual components can be taken from the relevant technical data.

5.2 Smart Line Modules Booksize Compact

5.2.1 Description

The Smart Line Module booksize compact is a non-regulated infeed/regenerative feedback unit. The Smart Line Module supplies the Motor Module with a non-regulated DC voltage at the DC output. In the infeed mode the Smart Line Module exhibits the typical current and voltage waveforms of a 6-pulse diode rectifier bridge.

In feedback mode, the current waveform is square waved. The regenerative feedback can be deactivated by means of parameters.

A line contactor can be installed on the line side if the system has to be electrically isolated from the line supply.

The Smart Line Module in booksize compact format can be used with cooling types "internal air cooling" or "cold plate". The cooling type is selected by parameter (see the SINAMICS S120/S150 List Manual).

Smart Line Modules are suitable for direct operation in TN, IT, and TT systems. The Line Modules have an integrated overvoltage protection function.

5.2.2 Safety instructions for Smart Line Modules Booksize Compact



! WARNING

Electric shock due to a high DC-link voltage

As long as the Line Module is connected to the line supply, the DC link is charged with a high voltage. A hazardous voltage can be present independent of the status of the LED "DC LINK" Contact with live parts and components can result in death or severe injury.

- Isolate the Line Module from the line supply during installation or maintenance work, e.g. via the line contactor or main switch.
- Observe the warning information on the component.



! WARNING

Electric shock due to the residual charge of the DC-link capacitors

Because of the DC link capacitors, a hazardous voltage is present for up to 5 minutes after the power supply has been switched off.

Contact with live parts can result in death or serious injury.

- Do not open the protective cover of the DC link until 5 minutes have elapsed.
- Measure the voltage before starting work on the DCP and DCN DC link terminals.



! WARNING

Electric shock when the protective cover of the DC link is open

Contact with live parts can result in death or serious injury.

- Only operate the components with closed protective cover.



! WARNING

Electric shock or fire due to overcurrent protective equipment that trips too late

Overcurrent protective equipment that trips too late or not all can cause electric shock or fire.

- To protect personnel and for fire protection purposes, at the infeed point, the short-circuit rating and loop impedance must match the specifications in the documentation so that the installed overcurrent protection devices trip within the specified time.



! WARNING

Electric shock due to improper DC link connection

Incorrect connections can lead to overheating and therefore fire. There is also a risk of an electric shock. This can result in serious injury or death.

- Only use adapters (DC link adapters and DC link rectifier adapters) released by Siemens for the connection to the DC link.



! WARNING

Electric shock due to missing DC-link side covers

Live parts are exposed if the DC link side covers are not fitted. Contact with these live parts could cause an electric shock.

- Mount the side covers on the first and last component in the drive line-up.
- Order any missing side covers (Article number: 6SL3162-5AA00-0AA0).



! WARNING

High leakage currents when the protective conductor in the line feeder cable is interrupted

The drive components conduct a high leakage current via the protective conductor. Touching conductive parts when the protective conductor is interrupted can result in death or serious injury.

- Carefully comply with the applicable regulations for dimensioning the protective conductor (see Chapter "Protective connection and equipotential bonding (Page 714)").

! WARNING

Fire due to overheating when the required cable cross-sections of power cables is fallen below

Power cables with excessively low cross-sections can cause them to overheat. This can result in severe injury or death due to fire and smoke.

- Only use power cables with sufficiently large cross-sections. Take into account the routing type, ambient temperature and cable length.

 WARNING
Fire due to overheating when the total length of the power cables is exceeded
Overheating can result when the total length of the power cables is exceeded. This can result in severe injury or death due to fire and smoke.
<ul style="list-style-type: none">• Ensure that the total length of the power cables (motor supply cables and DC link cables) does not exceed the values specified in Chapter Combination options, Line Modules with line reactors and line filters (Page 120).

Note

Operation on line supplies where energy recovery is not possible

In line supply systems without energy recovery capability (e.g. a diesel generator), device faults can occur as the braking energy cannot be dissipated.

- For line supplies without regenerative feedback capability (e.g. diesel generator), deactivate the regenerative feedback capability of the Line Modules using the appropriate parameter (see SINAMICS S120/S150 List Manual).
 - The braking energy must then be dissipated via an additional Braking Module with braking resistor in the drive line-up.
-

NOTICE
Damage through use of incorrect DRIVE-CLiQ cables
Damage or malfunctions can occur on the devices or system when DRIVE-CLiQ cables are used that are either incorrect or have not been approved for this purpose.
<ul style="list-style-type: none">• Only use suitable DRIVE-CLiQ cables that have been approved by Siemens for the particular application.

Note

Malfunctions due to polluted DRIVE-CLiQ interfaces

Malfunctions can occur in the system through the use of polluted DRIVE-CLiQ interfaces.

- Cover unused DRIVE-CLiQ interfaces with the supplied blanking covers.
-

Note

Fan operation

Activation of the fan is dependent on heat sink temperature and pulse enable.

5.2.3 Interface description

5.2.3.1 Overview

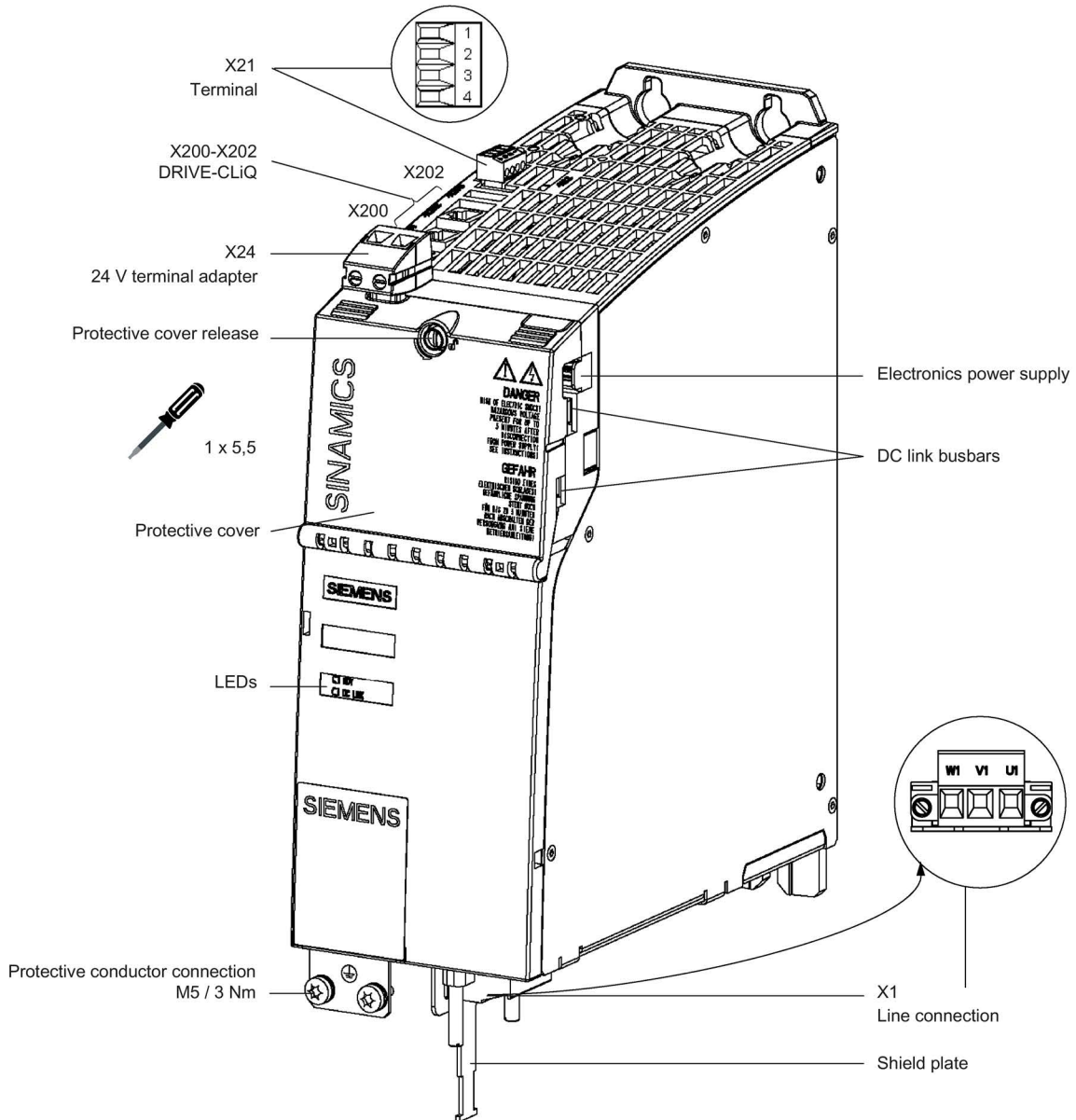
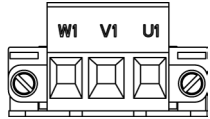
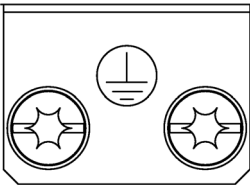

Figure 5-1 Interface overview, Smart Line Module in Booksize Compact format (16 kW)

5.2.3.2 X1 line connection

Table 5- 1 X1 line connection

	Terminal	Technical data
	U1	Supply voltage: 3 AC 380 ... 480 V, 50 / 60 Hz Type: Screw terminal 7 (Page 708)
	V1	
	W1	
	Protective conductor connection	Threaded hole M5 / 3 Nm (26.6 lbf in) ¹⁾
¹⁾ For ring cable lugs without insulation (Page 710)		

5.2.3.3 X21 EP terminals

Table 5- 2 X21 EP terminal / temperature sensor

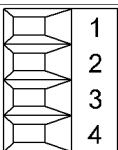
	Terminal	Function	Technical data
	1	+ Temp	Temperature sensors: KTY84-1C130 ¹⁾ / PT1000 ¹⁾ / PTC ¹⁾ /bimetallic switch with NC contact The temperature sensor type and the temperature display can be selected via parameter and read-out. ²⁾
	2	- Temp	
	3	EP +24 V (pulse enable)	Voltage: 24 V DC (20.4 ... 28.8 V)
	4	EP M (Enable Pulses)	Current consumption, typical: 4 mA at 24 V Isolated input
Type: Screw terminal 1 (Page 708)			

¹⁾ The temperatures are detected but not evaluated in the Smart Line Module.

²⁾ For further information see SINAMICS S120, Commissioning Manual

Terminals X21.1 and X21.2 - temperature sensor connection



! WARNING
<p>Electric shock due to voltage flashovers on the temperature sensor cable</p> <p>When using temperature sensors which are not isolated from the power circuit in accordance with the prescriptions for safe electrical separation, voltage flashovers could occur in the signal electronics.</p> <ul style="list-style-type: none"> • Only use temperature sensors that fully comply with the specifications of protective separation. • If safe electrical separation cannot be guaranteed (for linear motors or third-party motors, for example), use a Sensor Module External (SME120 or SME125) or Terminal Module TM120.

NOTICE
<p>Damage to motor in the event of incorrectly connected KTY temperature sensor</p> <p>A KTY temperature sensor connected with incorrect polarity cannot detect if the motor overheats. Overheating can cause damage to the motor.</p> <ul style="list-style-type: none"> • Connect the KTY temperature sensor with the correct polarity.

Terminals X21.3 and X21.4

For operation, the 24 V DC voltage must be connected to terminal X21.3 and ground to terminal X21.4.

Pulse cancellation is activated if the power supply is disconnected. As a consequence, regenerative feedback is deactivated and the bypass relay drops out. If the Line Module is not disconnected from the line supply when the EP terminal is de-energized, for example, because a line contactor is not installed, then the DC link remains charged.

5.2.3.4 X24 24 V terminal adapter

Table 5- 3 X24: 24 V terminal adapter

	Terminal	Designation	Technical data
	+	24 V power supply	24 V DC supply voltage
	M	Ground	Electronics ground
Type: Screw terminal 5 (Page 708)			

The 24 V terminal adapter is included in the scope of supply.

5.2.3.5 X200-X202 DRIVE-CLiQ interfaces

Table 5- 4 X200-X202: DRIVE-CLiQ interfaces

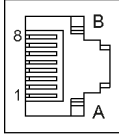
	PIN	Signal name	Technical data
	1	TXP	Transmit data +
	2	TXN	Transmit data -
	3	RXP	Receive data +
	4	Reserved, do not use	-
	5	Reserved, do not use	-
	6	RXN	Receive data -
	7	Reserved, do not use	-
	8	Reserved, do not use	-
	A	+(24 V)	24 V power supply
	B	M (0 V)	Electronics ground

The blanking covers for the DRIVE-CLiQ interfaces are included in the scope of delivery.

Blanking cover (50 pcs.) Article number: 6SL3066-4CA00-0AA0

5.2.4 Connection example

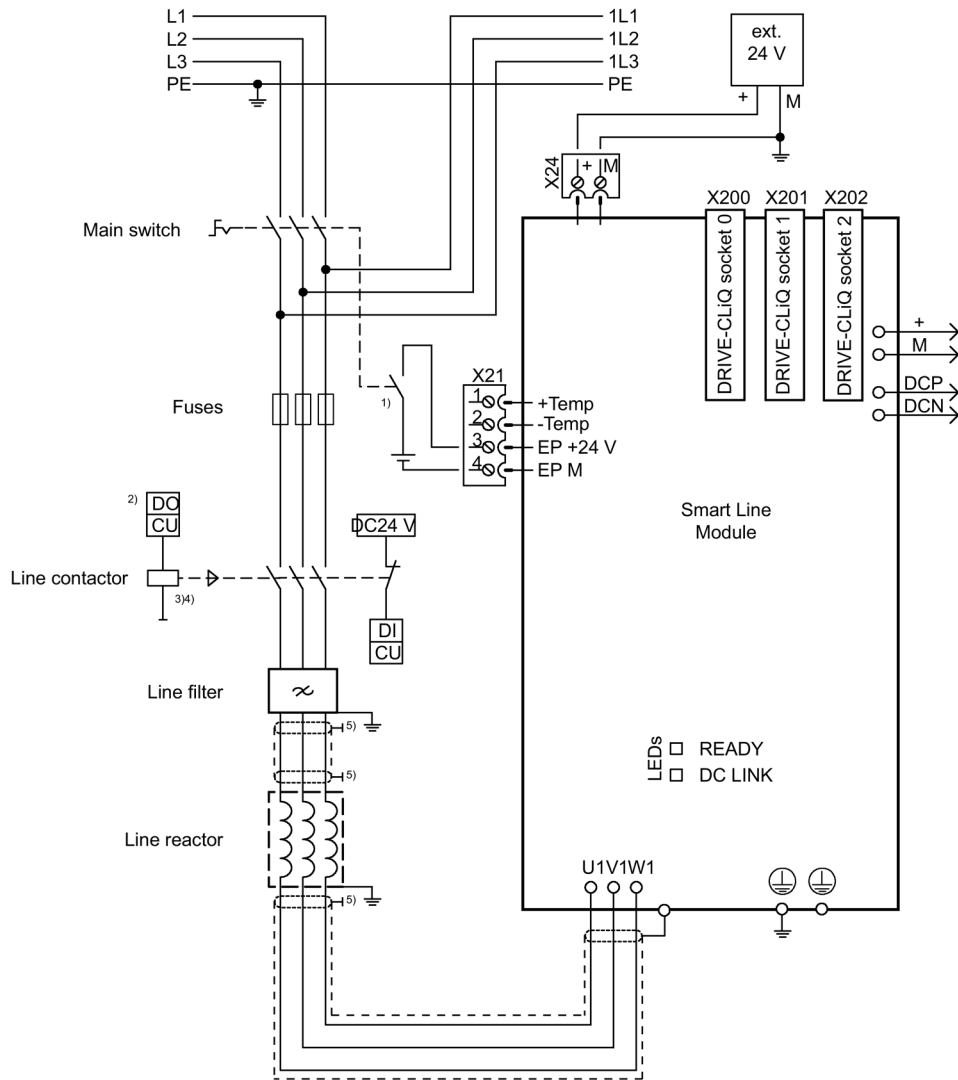

- 1) Leading opening contact, $t > 10$ ms
- 2) DI/DO, controlled from the Control Unit
- 3) No additional load permitted downstream of the line contactor
- 4) The current carrying capacity of the DO must be observed; an output coupling device may have to be used.
- 5) Contact established through the rear mounting panel or shield rails in accordance with the EMC installation guideline

Figure 5-2 Connection example, Smart Line Module Booksize Compact 16 kW

Note

If you are using a VSM10 Voltage Sensing Module, the leading opening contact can be omitted.

5.2.5 Meaning of the LEDs

Table 5- 5 Meaning of the LEDs on the Smart Line Module booksize compact

Status		Description, cause	Remedy
RDY	DC LINK		
Off	Off	The electronics power supply is missing or outside the permissible tolerance range.	–
Green	-- ¹⁾	The component is ready for operation. Cyclic DRIVE-CLiQ communication is taking place.	–
	Orange	The component is ready for operation. Cyclic DRIVE-CLiQ communication is taking place. The DC link voltage is present.	–
	Red	The component is ready for operation. Cyclic DRIVE-CLiQ communication is taking place. The DC link voltage is outside the permissible tolerance range.	Check the line supply voltage.
Orange	Orange	DRIVE-CLiQ communication is being established.	–
Red	-- ¹⁾	This component has at least one fault.	Resolve and acknowledge the fault.
Green/red (0.5 Hz)	-- ¹⁾	Firmware is being downloaded.	–
Green/red (2 Hz)	-- ¹⁾	Firmware download has been completed. The system waits for POWER ON.	Carry out a POWER ON.
Green/orange or Red/orange	-- ¹⁾	Component recognition via LED is activated ²⁾ . Note: Both options depend on the LED status when component recognition is activated.	–

¹⁾ Irrespective of the status of the LED "DC LINK"

²⁾ For information about activating the parameter "Recognition via LED", see SINAMICS S120/S150 List Manual

5.2.6 Dimension drawing

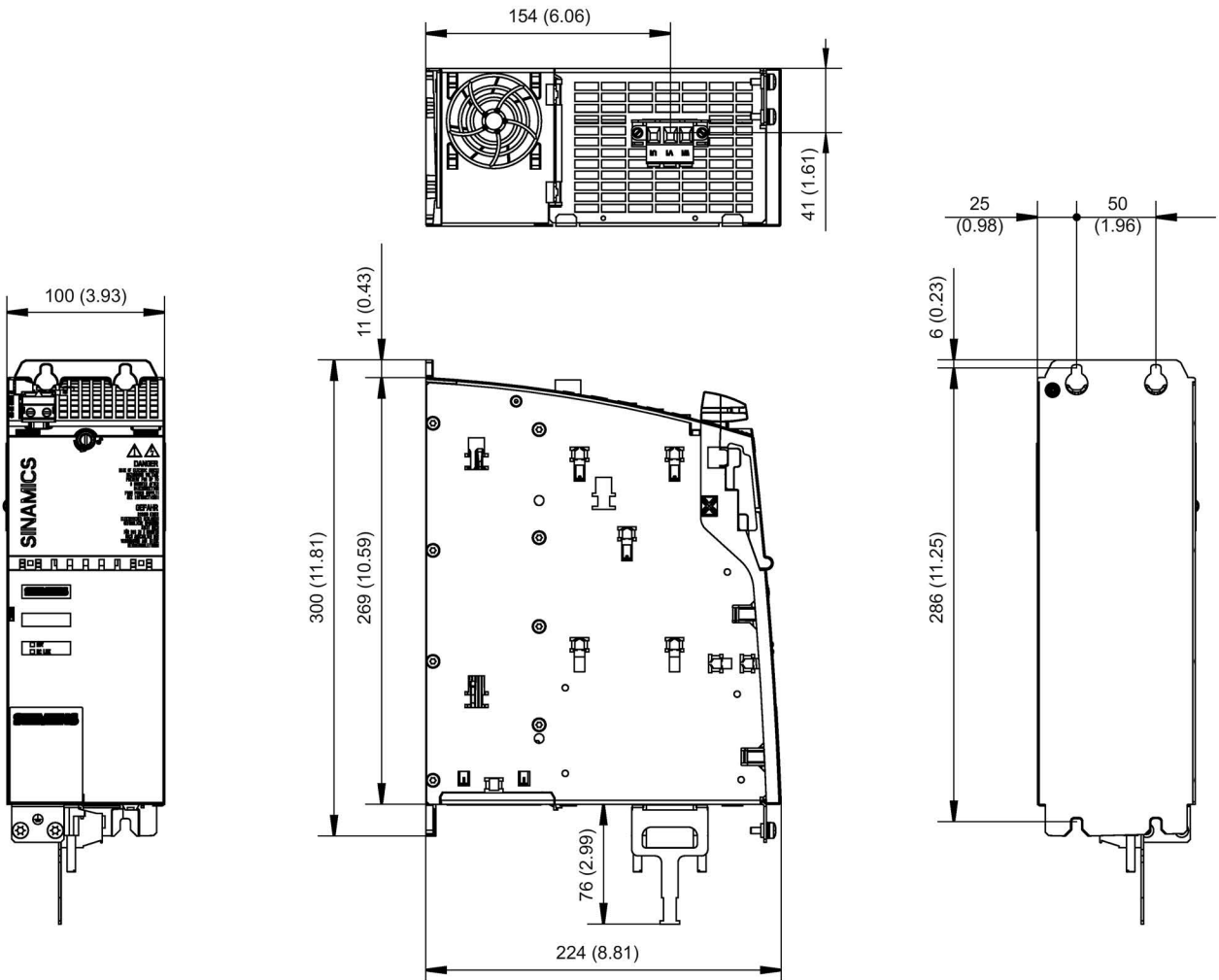

Figure 5-3 Dimension drawing Smart Line Module Booksize Compact format (16 kW), all dimensions in mm and (inches)

Note

The shield connecting plate is part of the scope of delivery of the Smart Line Modules Booksize Compact.

5.2.7 Mounting

Mounting a Smart Line Module Booksize Compact with internal air cooling

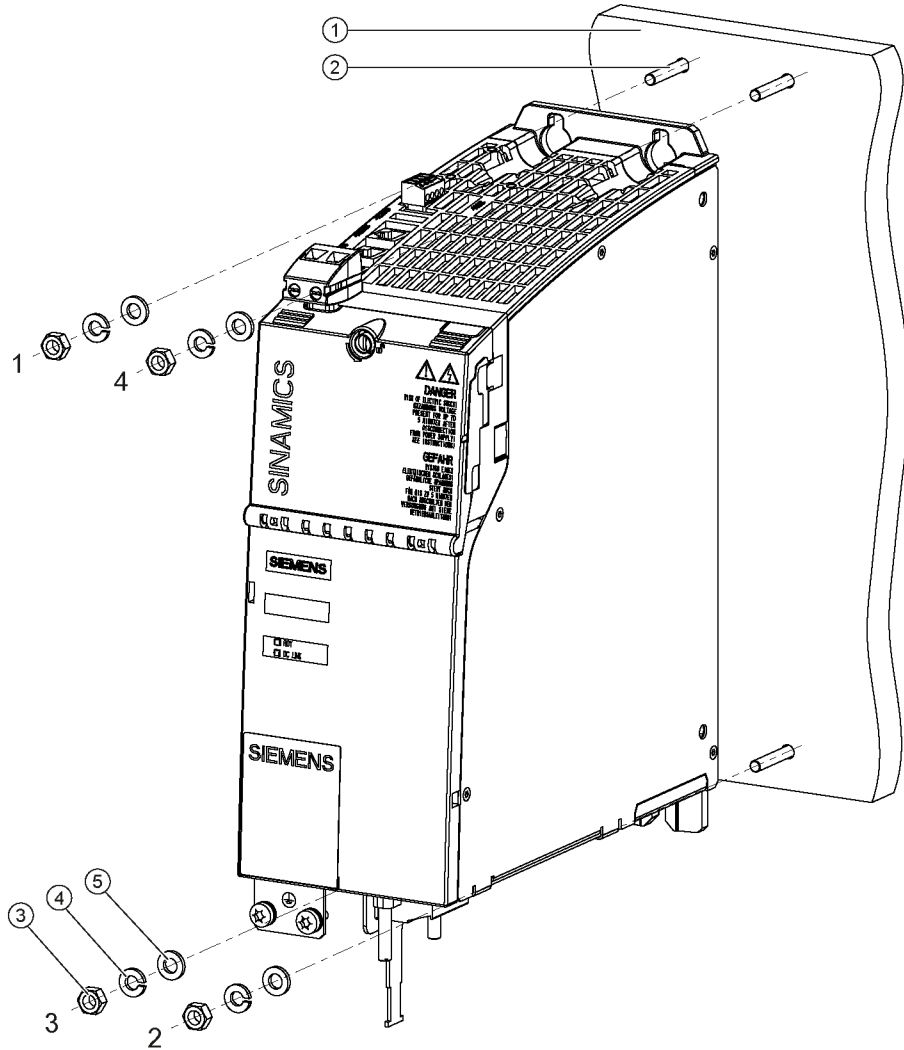

- ① Mounting panel
- ② Threaded bolts M6
- ③ M6 nut
- ④ Spring washer
- ⑤ Washer

Figure 5-4 Mounting a Smart Line Module Booksize Compact with internal cooling

Tightening torques:

1. Firstly, only tighten the nuts by hand.
Tightening torque: 0.5 Nm (4.4 lbf in)
2. Then tighten the nuts in the specified sequence 1 to 4.
Tightening torque: 6 Nm (53.1 lbf in)

Mounting a Smart Line Module Booksize Compact on a cold plate

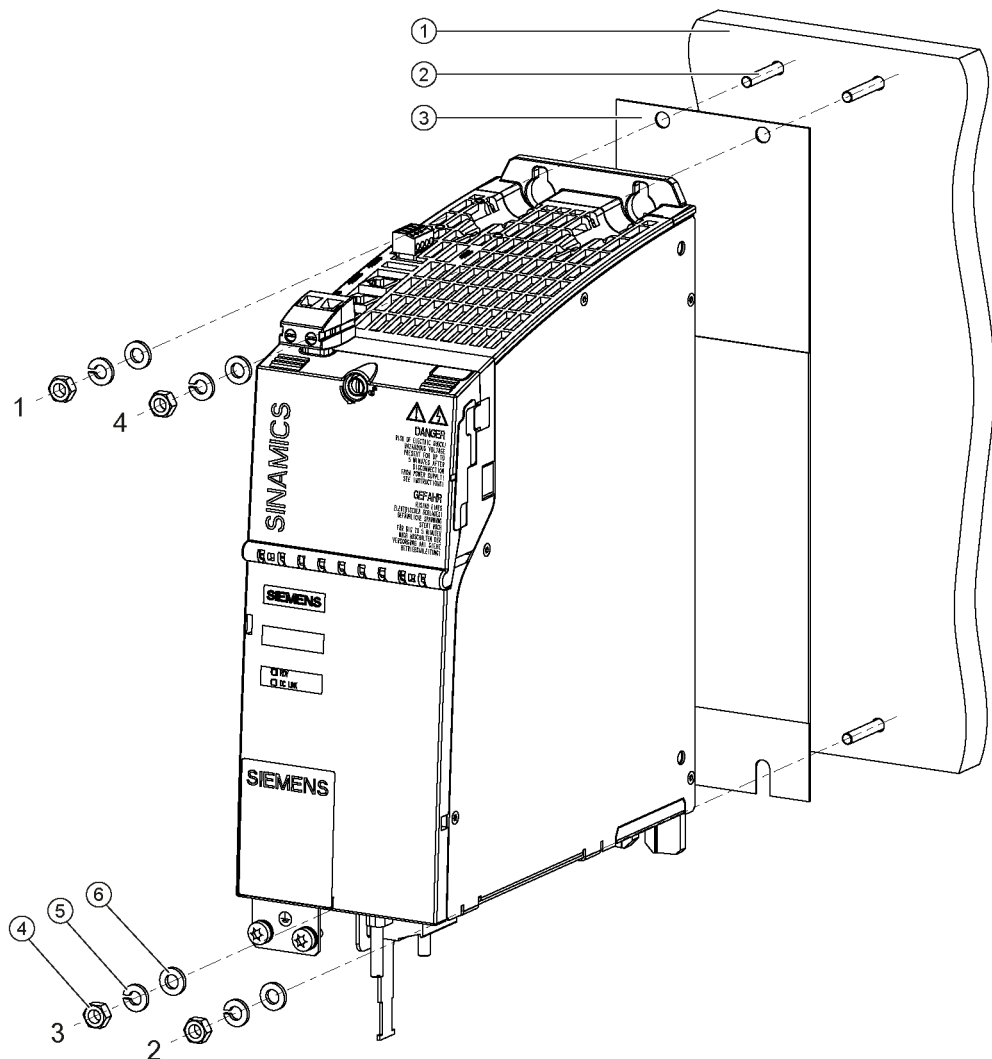

- ① Cold plate
- ② Threaded bolts M6
- ③ Heat-conducting foil
- ④ M6 nut
- ⑤ Spring washer
- ⑥ Washer

Figure 5-5 Mounting a Smart Line Module Booksize Compact on a cold plate

Tightening torques:

1. Firstly, only tighten the nuts by hand.
Tightening torque: 0.5 Nm (4.4 lbf in)
2. Then tighten the nuts in the specified sequence 1 to 4.
Tightening torque: 10 Nm (88.5 lbf in)

Special points to note in relation to mounting on a cold plate

To improve heat transfer, a heat-conducting medium must be used. Special spherical-indented heat-conducting foil must be used for this purpose. Every Smart Line Module Booksize Compact is supplied with heat-conducting foil cut to the right size. Note the mounting position of the heat-conducting foil.

Note

Use heat conducting foil

- Also replace the heat-conducting foil when replacing a component.
- Only use heat-conducting foil released or supplied by Siemens.

Table 5- 6 Heat-conducting foil

	Article No.
Heat-conducting foil, 100 mm	6SL3162-6FD01-0AA0

5.2.8 Technical data

Table 5- 7 Technical data Smart Line Modules Booksize Compact

Smart Line Module Booksize Compact	6SL3430–	6TE21-6AA.
Rated power	kW	16
Infeed¹⁾		
Rated power S1 duty	kW (P _n)	16
Infeed power S6 duty (40 %)	kW (P _{S6})	21
Peak infeed power	kW (P _{max})	35
Regenerative feedback		
Continuous regenerative power	kW	16
Peak regenerative power	kW	35
Supply voltages		
Line voltage	V _{AC}	3 AC 380 ... 480 ± 10 % (-15 % < 1 min)
Line frequency	Hz	47 ... 63
Electronics power supply	V _{DC}	24 (20.4 ... 28.8)
DC-link voltage	V _{DC}	510 ... 720
Overvoltage trip	V _{DC}	820 ± 2 %
Undervoltage trip ²⁾	V _{DC}	360 ± 2 %

Smart Line Module Booksize Compact	6SL3430–	6TE21-6AA.
Rated power	kW	16
Input currents Rated input current at AC 400 V Input current at AC 380 V / AC 480 V at AC 400 V; S6 duty (40 %) at AC 400 V; peak current	A _{AC} A _{AC} A _{AC} A _{AC}	27.5 29 / 24.5 35 57.5
DC-link currents Rated DC-link current at 600 V DC DC-link current at 510 V DC / 720 V DC at 600 V DC; S6 duty (40%) at 600 V DC; peak current	A _{DC} A _{DC} A _{DC} A _{DC}	27 30 / 22.2 35 59
Current carrying capacity DC link busbars Reinforced DC link busbars 24 V busbar:	A _{DC} A _{DC} A _{DC}	100 150 20
Electronics current consumption at 24 V DC For internal air cooling For cold plate cooling	A _{DC} A _{DC}	0.95 0.85
Total power loss internal air cooling (including electronics losses, see Power loss tables (Page 734))	W	187.8
Power loss distribution for cold plate (including electronics losses) Internal External	W W	56.6 130
DC link capacitance Smart Line Module Drive line-up, max.	μF μF	705 6000
Power factor	cos φ	0.98
Circuit breaker (IEC 60947 and UL)		See Chapter Overcurrent protection using line fuses and circuit breakers (Page 47)
Max. total cable length ³⁾		See Chapter Combination options, Line Modules with line reactors and line filters (Page 120)
Sound pressure level	dB(A)	< 60
Cooling methods		Internal air cooling Cold plate cooling
Cooling air requirement with internal air cooling	m ³ /h	56
Max. permissible heat-sink temperature cold plate	°C	71

Smart Line Module Booksize Compact	6SL3430-	6TE21-6AA.
Rated power	kW	16
Ventilation clearances above/below	mm	≥ 80
Weight	kg	5.3

- 1) The specified power ratings apply to the line voltage range from 380 V to 480 V.
- 2) Default for 400 V line systems; undervoltage trip threshold is adjusted to the parameterized rated voltage
- 3) Maximum total cable length = Σ motor cables, line feeder cable from line filter to the Line Module

5.2.8.1 Characteristics

Rated duty cycles of Smart Line Modules

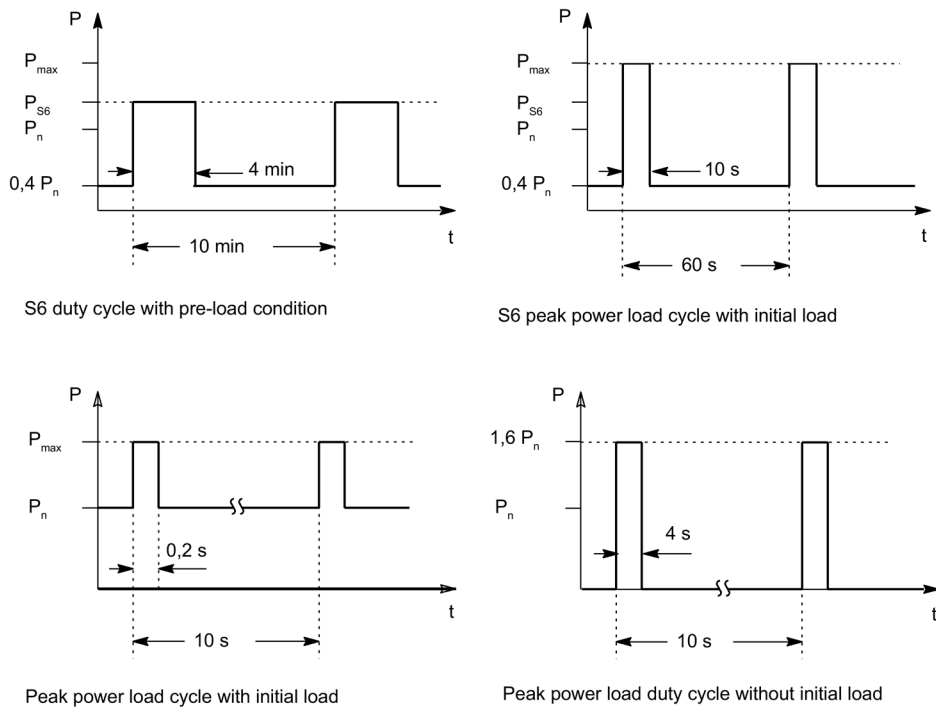

Figure 5-6 Rated duty cycles of Smart Line Modules

6.1 Safety instructions for Motor Modules Booksize



! WARNING

Electric shock due to the residual charge of the DC-link capacitors

Because of the DC link capacitors, a hazardous voltage is present for up to 5 minutes after the power supply has been switched off.

Contact with live parts can result in death or serious injury.

- Do not open the protective cover of the DC link until 5 minutes have elapsed.
- Measure the voltage before starting work on the DCP and DCN DC link terminals.



! WARNING

Electric shock when the protective cover of the DC link is open

Contact with live parts can result in death or serious injury.

- Only operate the components with closed protective cover.



! WARNING

Electric shock due to improper DC link connection

Incorrectly established connections can result in overheating and therefore fire with associated smoke. There is also a risk of an electric shock. This can result in serious injury or death.

- Only use adapters (DC link adapters and DC link rectifier adapters) released by Siemens for the connection to the DC link.





 WARNING
Electric shock due to incorrectly installed DC link bridges
Incorrectly installed DC link bridges at the left-hand end of the drive line-up can cause an electric shock.
<ul style="list-style-type: none">• For all 50 mm wide Motor Modules¹⁾, remove the DC link bridge including the screws. Do not tighten the screws without the DC link bridges.• For all components that are 75 mm wide or wider, the DC link bridges may neither be swung over to the left nor removed²⁾.
<p>¹⁾ For 50 mm wide modules, the DC link bridge cannot be swung inwards. ²⁾ The DC link bridge guarantees the mechanical stability of the DC link busbars.</p>



 WARNING
Electric shock due to missing DC-link side covers
There is a danger of an electric shock through contact when the side covers of the DC link are missing.
<ul style="list-style-type: none">• Mount the side covers on the first and last component in the drive line-up.• Order any missing side covers (Article number: 6SL3162-5AA00-0AA0).



 WARNING
Electric shock due to incorrectly laid brake cables
If brake cables are laid without safe electrical separation, the insulation can fail and cause an electric shock.
Install the brake in one of the following ways:
<ul style="list-style-type: none">• Connect the holding brake with the specified MOTION-CONNECT cable.• Only use third-party cables with safe electrically separated brake cores or lay the brake cores with safe electrical separation.

 WARNING
Fire as a result of overheated motor cables if cross-sections are smaller than the minimum permissible size
Excessively thin motor cables can result in overheating. This can result in severe injury or death due to fire and smoke.
<ul style="list-style-type: none">• Use cables that correspond to the Motor Module currents. Take into account the routing type, ambient temperature and cable length.• If smaller cross-sections are selected, you must ensure the appropriate level of conductor protection in another way, e.g. by suitably setting the control parameters.

NOTICE**Temperature signal disturbances and failure of components as a result of unshielded or incorrectly routed cables**

With unshielded or incorrectly laid cables, it can be expected that interference will be coupled into the signal processing electronics from the power side. This can result in significant disturbances (fault messages) up to failure of individual components (destruction of the devices).

- Only use shielded cables as temperature sensor cables.
- Only use temperature sensor cables that are routed together with the motor cable and twisted in pairs and shielded separately.
- Connect the cable shield to the chassis potential at both ends over a large surface area.

NOTICE**Premature wear of the motor holding brake when operated outside its permissible voltage range**

Operating the motor holding brake outside its permissible voltage range at the motor connection will damage the brake.

- Ensure that the motor holding brake is only operated within its permissible voltage range.

NOTICE**Damage through use of incorrect DRIVE-CLiQ cables**

Damage or malfunctions can occur on the devices or system when DRIVE-CLiQ cables are used that are either incorrect or have not been approved for this purpose.

- Only use suitable DRIVE-CLiQ cables that have been approved by Siemens for the particular application.

NOTICE**Motor damage due to the use of an unsuitable third-party motor**

The motor insulation is subject to higher stresses when operated with a converter. Damage to the motor winding may occur as a result.

- Observe the notes in the System Manual "Requirements placed on third-party motors (<https://support.industry.siemens.com/cs/document/79690594>)".

Note**Malfunctions due to polluted DRIVE-CLiQ interfaces**

Malfunctions can occur in the system through the use of polluted DRIVE-CLiQ interfaces.

- Cover unused DRIVE-CLiQ interfaces with the supplied blanking covers.

Special features for Motor Modules with external air cooling

Note

Insufficient cooling power when the external heat sinks are polluted

For components with external air cooling, the fan and the heat sinks can accumulate a lot of pollution. If the cooling air requirement is not provided by the filter fan, the components cannot output their specified power. This can cause the temperature monitoring function in the components to respond.

- Check the fans and heat sinks for pollution at regular intervals and clean them when necessary.
-

Note

Checking the seal

- After installation, check the seal on the rear of the device to ensure that it is tight.
 - If required, use additional sealing.
-

Note

Using an installation frame

- Only use an installation frame when the cabinet has an unpainted metal surface.
-

Notes for UL applications

Note

Motor overload protection

The Motor Module has integrated motor overload protection according to 61800-5-1. The protection threshold is 115 % of the full load current of the Motor Module. It can be adapted using parameter p5453 (see SINAMICS S120/S150 List Manual).

Note

The SINAMICS S120 Motor Modules Booksize provide short-circuit protection at the motor output terminals.

Fault protection for the motor circuit

Note

The electronic overcurrent trip complies with the requirements laid down in IEC 60364-3-2:2005/AMD1 - Section 411 for protection against electric shock.

- Observe the installation specifications provided in this manual.
 - Observe the applicable installation standards.
 - Ensure the continuity of the protective conductor.
-

6.2 Motor Modules with internal air cooling

6.2.1 Description

A Motor Module is a power unit (inverter) that provides the power for the connected motors. Power is supplied by the DC link of the drive unit. A Motor Module must be connected to a Control Unit via DRIVE-CLiQ. The open-loop and closed-loop control functions for the Motor Module are stored in the Control Unit.

One motor can be connected to Single Motor Modules and 2 motors can be connected to Double Motor Modules.

6.2.2 Interface description

6.2.2.1 Overview

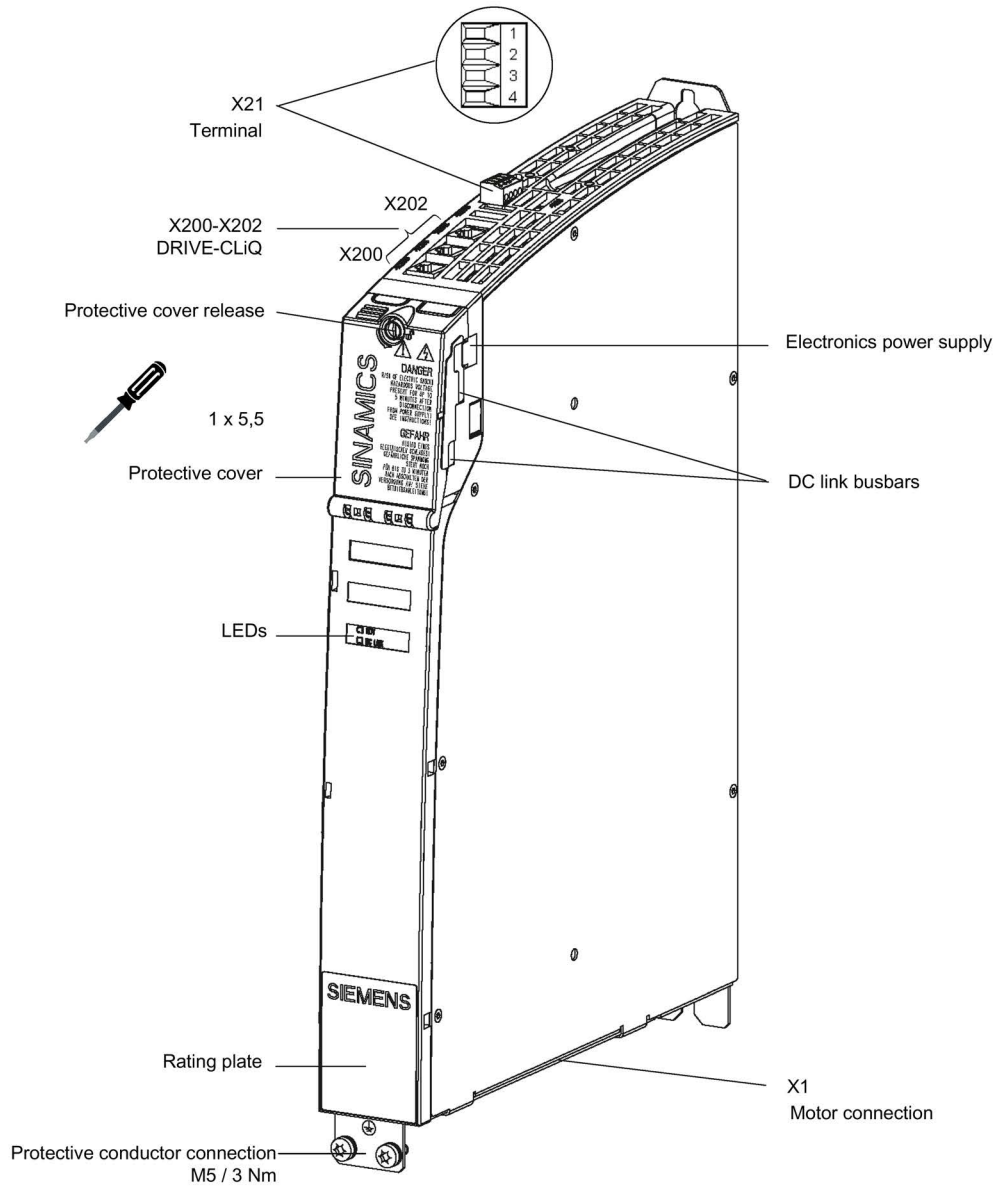

Figure 6-1 Interface overview, Single Motor Module Booksize with internal air cooling (example: 5 A)

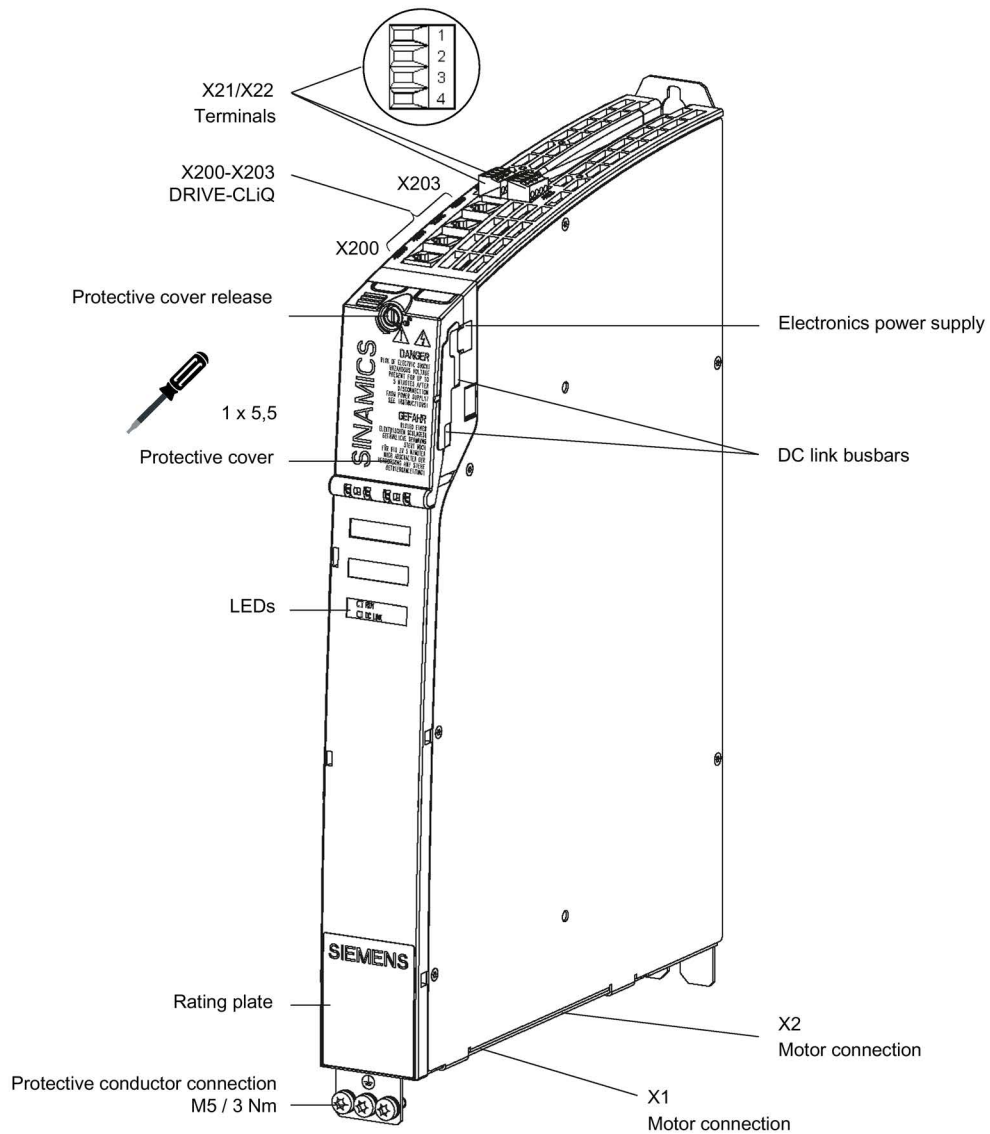

Figure 6-2 Interface overview, Double Motor Module Booksize with internal air cooling (example: 2 x 5 A)

6.2.2.2 Motor and brake connection

Table 6- 1 X1/X2 motor and brake connections for Single Motor Modules 3 A to 30 A and Double Motor Modules 2 x 3 A to 2 x 18 A

	Terminal	Technical data	
	U (U2)	Motor connection	
	V (V2)		
	W (W2)		
	+ (BR+)	Brake connection:	
	- (BR-)	Supply voltage: 24 V DC ±10% Max. load current: 2 A Minimum load current: 0.1 A	
	Protective conductor connection	Single Motor Modules 3 ... 30 A: Threaded hole M5 / 3 Nm (26.6 lbf in) ¹⁾	
		Double Motor Modules 2 x 3 ... 2 x 18 A: Threaded hole M5 / 3 Nm (26.6 lbf in) ¹⁾	
¹⁾ For ring cable lugs without insulation (Page 710)			

Table 6-2 X1 motor connection and X11 brake connection for Single Motor Modules 45 A to 200 A

	Terminal	Technical data
	U2	45 ... 60 A: Threaded bolts M6 / 6 Nm (53.1 lbf in) ¹⁾ 85 A: Threaded bolts M8 / 13 Nm (115 lbf in) ¹⁾ 132 ... 200 A: Threaded bolts M8 / 13 Nm (115 lbf in) ¹⁾
	V2	
	W2	
	Protective conductor connection	45 ... 60 A: Threaded bolts for motor cables: M6 / 6 Nm (53.1 lbf in) ¹⁾ Threaded hole for protective conductor: M6 / 6 Nm (53.1 lbf in) ¹⁾
		
	+ (BR+)	X11 brake connector²⁾: Supply voltage: 24 V DC ±10 % Max. load current: 2 A Minimum load current: 0.1 A Type: Spring-loaded terminal 2 (Page 708) The brake connector is part of the prefabricated cable.
	- (BR-)	

¹⁾ For ring cable lugs without insulation (Page 710)
²⁾ The circuit for protecting the brake against overvoltage is integrated in the Motor Module and does not need to be installed externally.

Motor holding brake connection

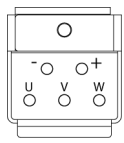
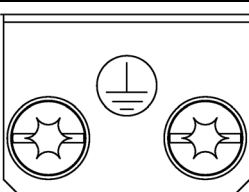
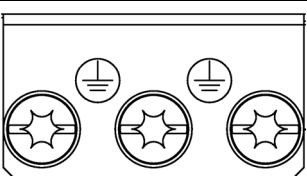
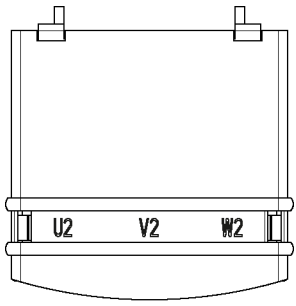
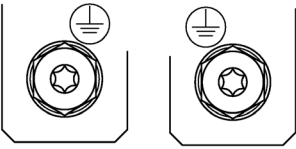
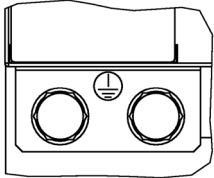
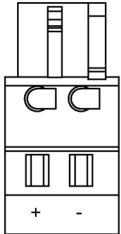
To ensure reliable opening of the motor holding brake, it requires a 24 V ± 10% voltage supply at the motor connection. It must be taken into account that voltage dips can occur along the supply cable.

- Use a Control Supply Module or a regulated DC power supply, whose setpoint is set to 26 V.
- Use supply cables with a minimum cross-section of 1.5 mm² (AWG 16) and a maximum length of 100 m.

Note

Protective circuit against overvoltage

The Motor Modules have an integrated overvoltage protection circuit for the motor holding brake. External protective circuits are not required.

 **WARNING**

High contact voltage on brake cables

For motor cables with integrated brake cable, when the motor is operated, the motor can charge the brake cable up to hazardous voltage levels. Coming into contact with the conductors or the shield of the brake cable can result in death or serious injury.

- Use motor cables with separate, shielded brake cables and connect the shield of the brake cable at both ends.

NOTICE

Premature wear of the motor holding brake when operated outside its permissible voltage range

Operating the motor holding brake outside its permissible voltage range at the motor connection will damage the brake.

- Ensure that the motor holding brake is only operated within its permissible voltage range.

NOTICE

Faulty brake function due to inadmissible wear

Inadmissible wear means that the braking function can no longer be guaranteed.

- Comply with the predefined Emergency Stop characteristics.
- Avoid repeated brief acceleration of the motor against a holding brake that is still closed. Consider the operating times of the brakes and the relays in the drive control and enable.

Note

The total length of the power cables (motor feeder cables and DC link cables) must not exceed the values listed in Chapter "Combination options, Line Modules with line reactors and line filters (Page 120)".

Note

The motor brake must be connected via connector X11. It is not permitted to directly connect the cable BR- to the electronics ground M.

6.2.2.3 X12 fan connection

The Motor Modules 132 A and 200 A are equipped with an interface to connect a sub-chassis fan. The interface is located on the underside of the Motor Module.

Table 6- 3 X12 fan connection

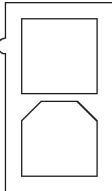
	Terminal	Function	Technical data
	1	Fan connection +	Voltage 48 V DC for the supplied fan
	2	Fan connection -	

6.2.2.4 X21/X22 EP terminals/temperature sensor

Table 6- 4 X21/X22 EP terminals / temperature sensor

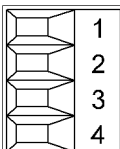
	Terminal	Function	Technical data
	1	+ Temp	Temperature sensors: KTY84-1C130 / PT1000 / PTC / bimetallic switch with NC contact
	2	- Temp	
	3	EP +24 V (pulse enable)	Supply voltage: 24 V DC (20.4 ... 28.8 V) Current consumption, typical: 4 mA at 24 V Isolated input The pulse inhibit function is only available when the "Safety Integrated Basic Functions via onboard terminals" software is enabled.
	4	EP M1 (enable pulses)	

Type: Screw terminal 1 (Page 708)

EP terminals

Parameters p9651 and p9851 are used to set the filter times for debouncing terminals X21.3 and X21.4, as well as X22.3 and X22.4 (see SINAMICS S120/S150 List Manual). Additional parameter settings are also required in order to prevent discrepancy errors when performing bit pattern tests (light/dark tests). For comprehensive information, see the SINAMICS S120 Safety Integrated Function Manual, Section "Controlling the safety functions".

Note

Function of the EP terminals

The function of the EP terminals for pulse inhibit is only available if the "Safety Integrated Basic Functions via onboard terminals" software is enabled.

Temperature sensor connection

<p>NOTICE</p> <p>Damage to motor in the event of incorrectly connected KTY temperature sensor</p> <p>A KTY temperature sensor connected with incorrect polarity cannot detect if the motor overheats. Overheating can cause damage to the motor.</p> <ul style="list-style-type: none"> • Connect the KTY temperature sensor with the correct polarity.
--

Note

The temperature sensor input is not needed if the motors feature an integrated DRIVE-CLiQ interface or if temperature values are detected by means of a different module (SMC, SME, TM).



<p>! WARNING</p> <p>Electric shock in the event of voltage flashovers at the temperature sensor</p> <p>Voltage flashovers in the signal electronics can occur in motors without safe electrical separation of the temperature sensors.</p> <ul style="list-style-type: none"> • Use temperature sensors that comply with the specifications relating to protective separation. • If safe electrical separation cannot be guaranteed (for linear motors or third-party motors, for example), use a Sensor Module External (SME120 or SME125) or Terminal Module TM120.

6.2.2.5 X200-X203 DRIVE-CLiQ interface

Table 6- 5 X200-X202: DRIVE-CLiQ interfaces for Single Motor Modules
X200-X203: DRIVE-CLiQ interfaces for Double Motor Modules

	Pin	Name	Technical data
	1	TXP	Transmit data +
	2	TXN	Transmit data -
	3	RXP	Receive data +
	4	Reserved, do not use	-
	5	Reserved, do not use	-
	6	RXN	Receive data -
	7	Reserved, do not use	-
	8	Reserved, do not use	-
	A	+ (24 V)	Power supply
	B	M (0 V)	Electronics ground

The blanking covers for the DRIVE-CLiQ interfaces are included in the scope of delivery.

Blanking cover (50 pcs.) Article number: 6SL3066-4CA00-0AA0

6.2.3 Connection examples

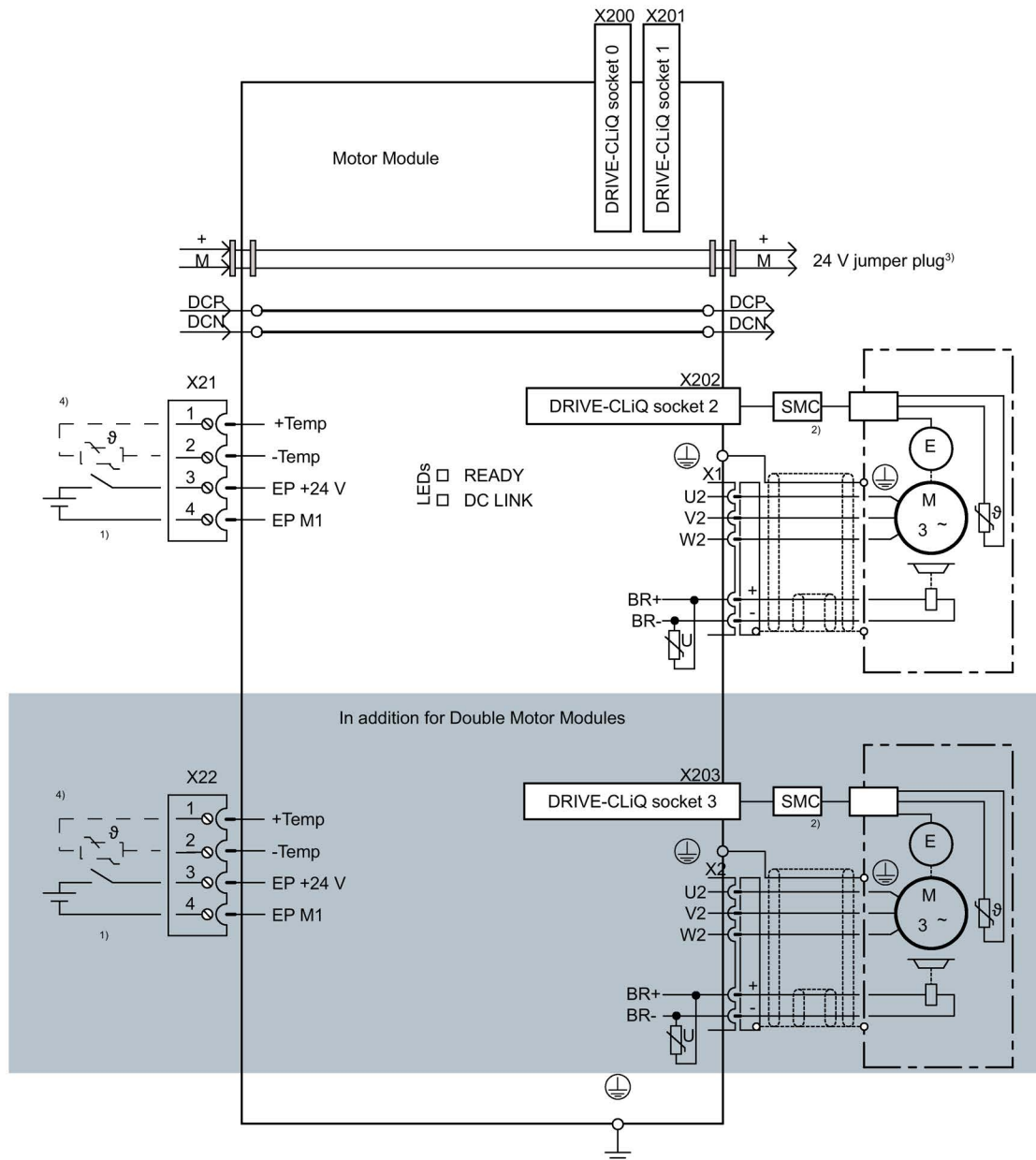

- 1) Required for safety
- 2) SMC required for motors without DRIVE-CLiQ interface
- 3) 24 V to the next module
- 4) Optional, e.g. for motor without encoder

Figure 6-3 Connection example of Motor Modules 3 A to 30 A and Double Motor Modules 2 x 3 A to 2 x 18 A

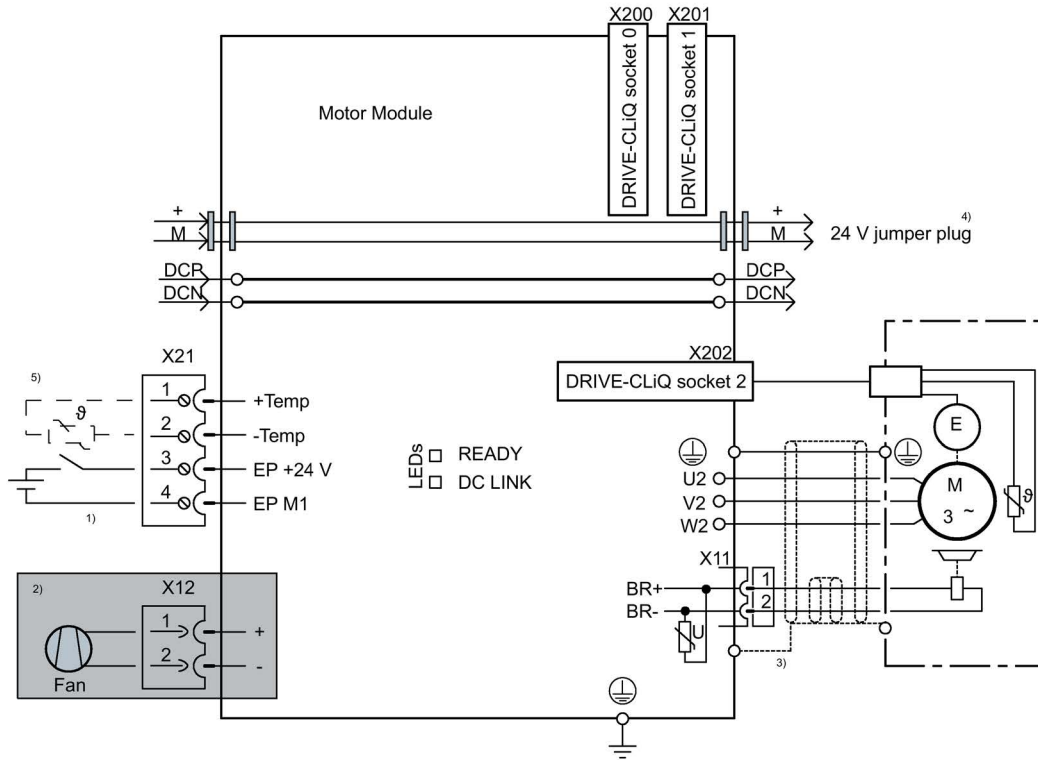

- 1) Required for safety
- 2) In addition for Motor Modules 132 A to 200 A
- 3) Contact established through the shield plate
- 4) 24 V to the next module
- 5) Optional, e.g. for motor without encoder

Figure 6-4 Example connection of Single Motor Modules 45 A to 200 A

6.2.4 Meaning of LEDs

Table 6- 6 Meaning of the LEDs on the Motor Module

Status		Description, cause	Remedy
RDY	DC LINK		
Off	Off	The electronics power supply is missing or outside the permissible tolerance range.	–
Green	-- ¹⁾	The component is ready for operation. Cyclic DRIVE-CLiQ communication is taking place.	–
	Orange	The component is ready for operation. Cyclic DRIVE-CLiQ communication is taking place. The DC link voltage is present.	–
	Red	The component is ready for operation. Cyclic DRIVE-CLiQ communication is taking place. The DC link voltage is outside the permissible tolerance range.	Check the line supply voltage.
Orange	Orange	DRIVE-CLiQ communication is being established.	–
Red	-- ¹⁾	This component has at least one fault.	Resolve and acknowledge the fault.
Green/red (0.5 Hz)	-- ¹⁾	Firmware is being downloaded.	–
Green/red (2 Hz)	-- ¹⁾	Firmware download has been completed. The system waits for POWER ON.	Carry out a POWER ON.
Green/orange or red/orange	-- ¹⁾	Component recognition via LED is activated ²⁾ . Note: Both options depend on the LED status when component recognition is activated.	–

¹⁾ Irrespective of the status of the LED "DC LINK"

²⁾ For information about activating the parameter "Recognition via LED", see SINAMICS S120/S150 List Manual

6.2.5 Dimension drawings

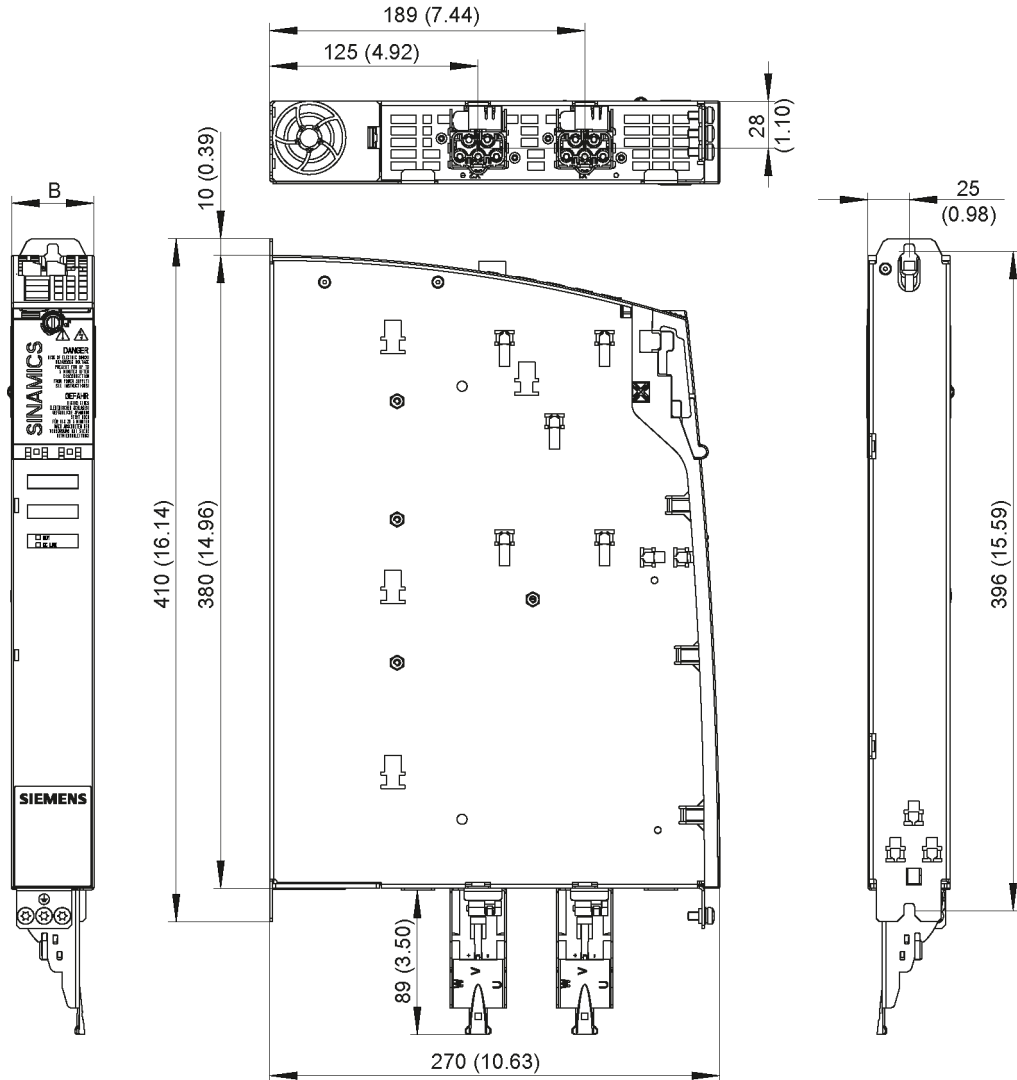

Figure 6-5 Dimension drawing of Motor Modules Booksize with internal air cooling 3 A to 18 A and 2 x 3 A to 2 x 9 A, all dimensions in mm and (inches); example: Double Motor Module 2 x 5 A

Table 6-7 Dimensions of Motor Modules Booksize with internal air cooling 3 A to 18 A and 2 x 3 A to 2 x 9 A

Motor Module	Article No.	B [mm] (inch)
Single Motor Module 3 A	6SL3120-1TE13-0AA.	50 (1.97)
Single Motor Module 5 A	6SL3120-1TE15-0AA.	
Single Motor Module 9 A	6SL3120-1TE21-0AA.	
Single Motor Module 18 A	6SL3120-1TE21-8AA.	
Double Motor Module 2 x 3 A	6SL3120-2TE13-0AA.	
Double Motor Module 2 x 5 A	6SL3120-2TE15-0AA.	
Double Motor Module 2 x 9 A	6SL3120-2TE21-0AA.	

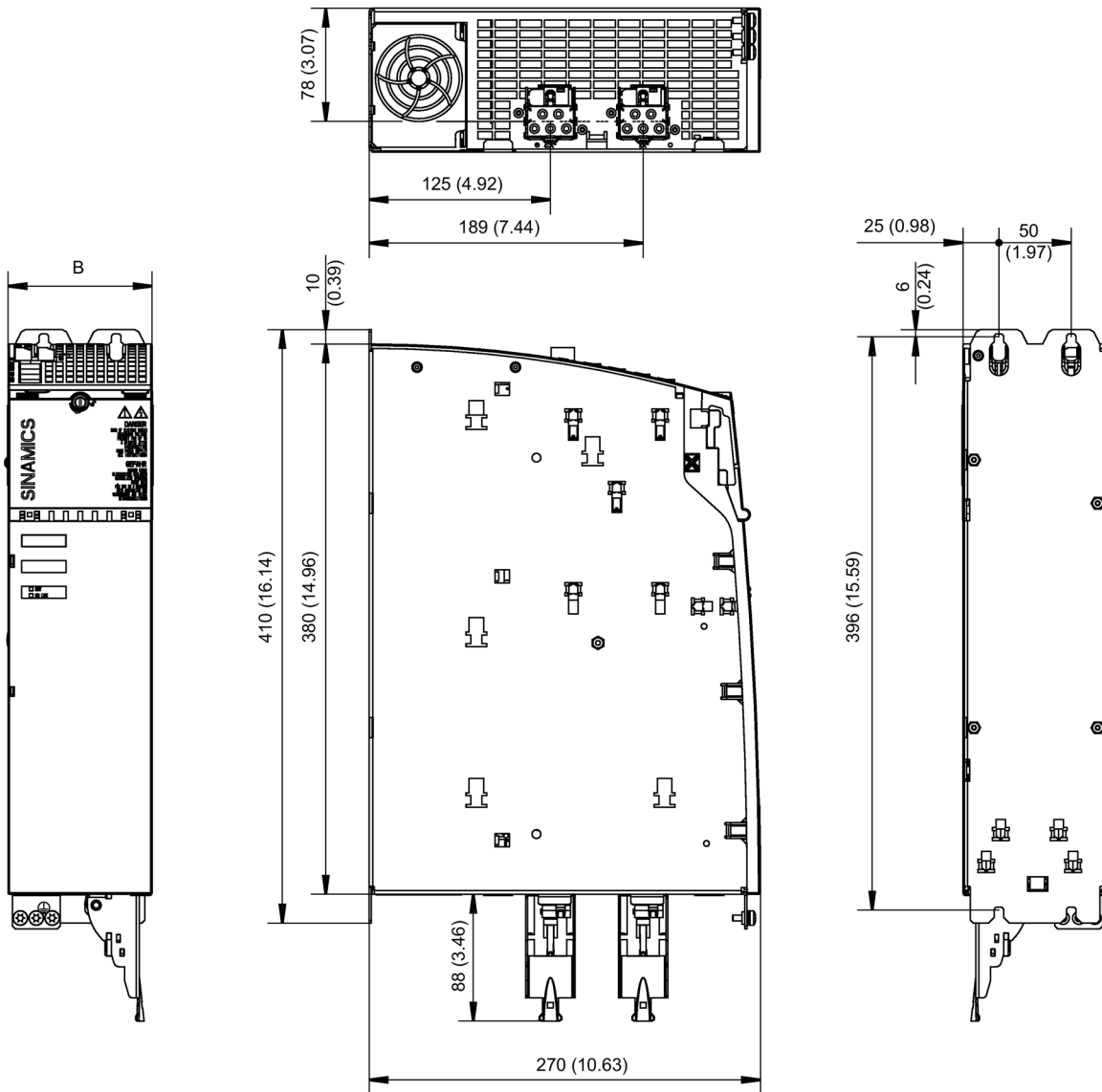

Figure 6-6 Dimension drawing of Motor Modules Booksize with internal air cooling 30 A and 2 x 18 A, all dimensions in mm and (inches); example: Double Motor Module 2 x 18 A

Table 6- 8 Dimensions of Motor Modules Booksize with internal air cooling 30 A and 2 x 18 A

Motor Module	Article No.	B [mm] (inch)
Single Motor Module 30 A	6SL3120-1TE23-0AA.	100 (3.94)
Double Motor Module 2 x 18 A	6SL3120-2TE21-8AA.	

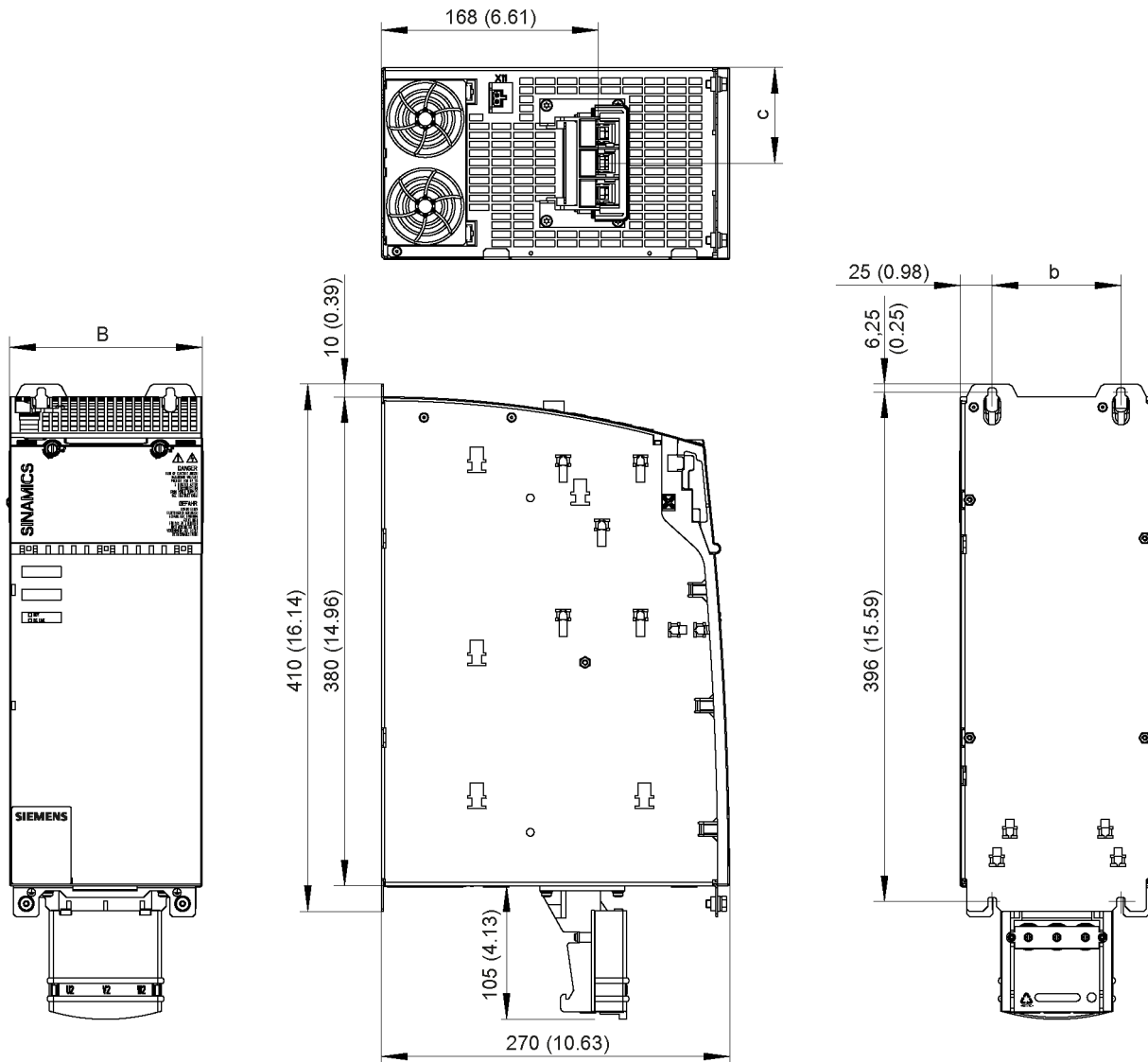

Figure 6-7 Dimension drawing of Motor Modules Booksize with internal air cooling 45 A to 85 A, all dimensions in mm and (inches); example 45 A

Table 6-9 Dimensions of Motor Modules Booksize with internal air cooling 45 A to 85 A

Motor Module	Article No.	B [mm] (inch)	b [mm] (inch)	c [mm] (inch)
Single Motor Module 45 A	6SL3120-1TE24-5AA.	150 (5.91)	100 (3.94)	75 (2.95)
Single Motor Module 60 A	6SL3120-1TE26-0AA.			
Single Motor Module 85 A	6SL3120-1TE28-5AA.	200 (7.87)	150 (5.91)	100 (3.94)

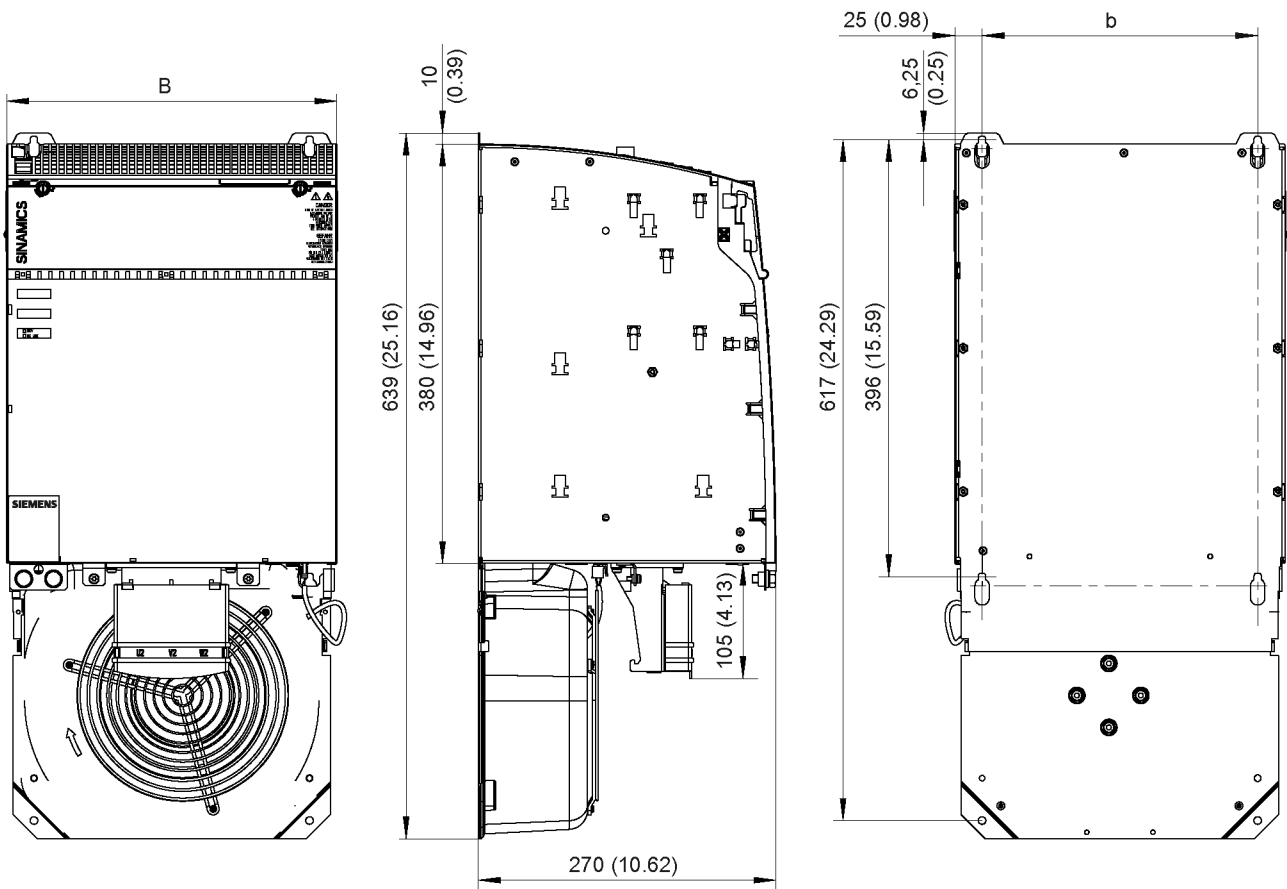

Figure 6-8 Dimension drawing of Motor Modules Booksize with internal air cooling 132 A and 200 A, all dimensions in mm and (inches)

Table 6- 10 Dimensions of Motor Modules Booksize with internal air cooling 132 A and 200 A

Motor Module	Article No.	B [mm] (inch)	b [mm] (inch)
Single Motor Module 132 A	6SL3120-1TE31-3AA.	300 (11.81)	250 (9.84)
Single Motor Module 200 A	6SL3120-1TE32-0AA.		

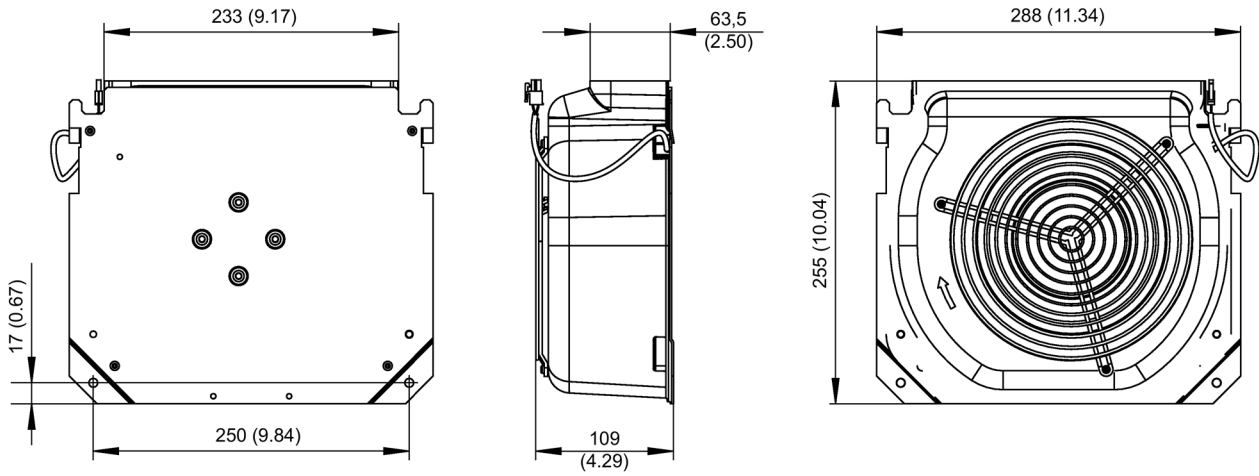

Figure 6-9 Dimension drawing of fans for Motor Modules 132 A and 200 A with internal air cooling, all dimensions in mm and (inches)

Note

The fan for the Motor Modules 132 A and 200 A is included in the scope of supply.

6.2.6 Installation

Motor Modules are designed for installation in the control cabinet. They are fixed to the control cabinet panel or a mounting panel using M6 screws.

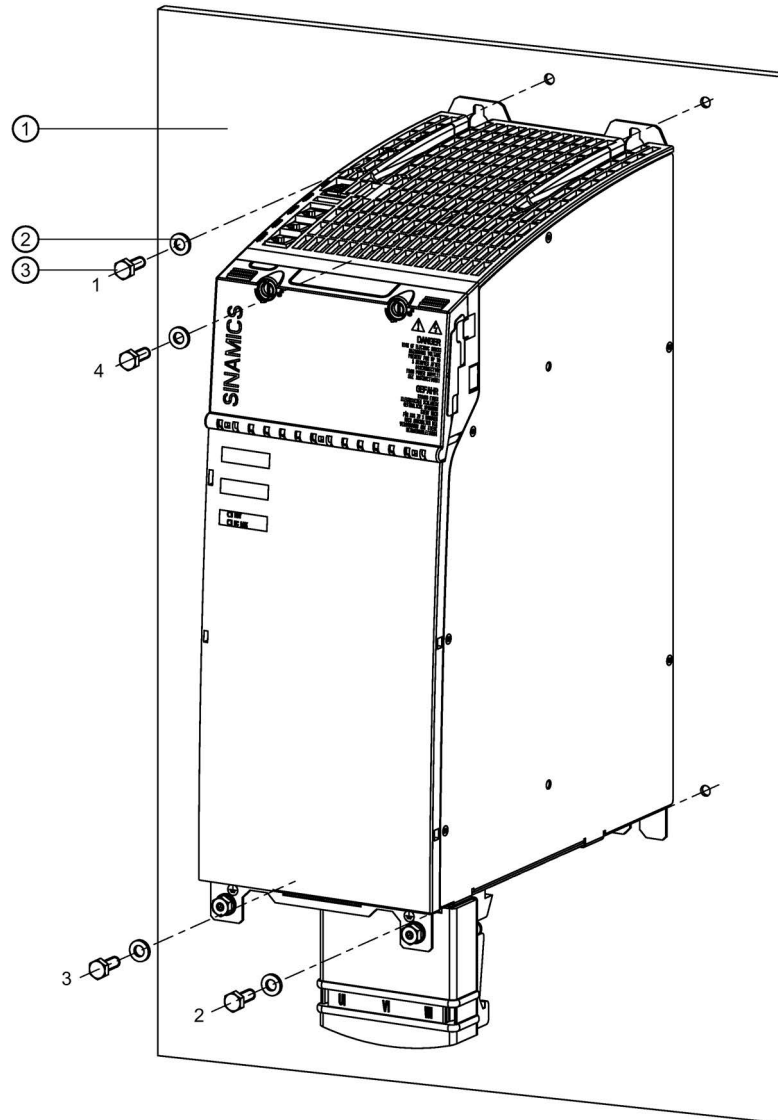

- ① Control cabinet panel/mounting panel
- ② Washer
- ③ M6 screw

Figure 6-10 Installation of a Motor Module with internal air cooling (example 45 A)

Tightening torques:

1. Firstly, tighten the nuts by hand.
Tightening torque. 0.5 Nm (4.4 lbf in)
2. Then tighten the screws in the specified sequence 1 to 4.
Tightening torque: 6 Nm (53.1 lbf in)

Installing the sub-chassis fan

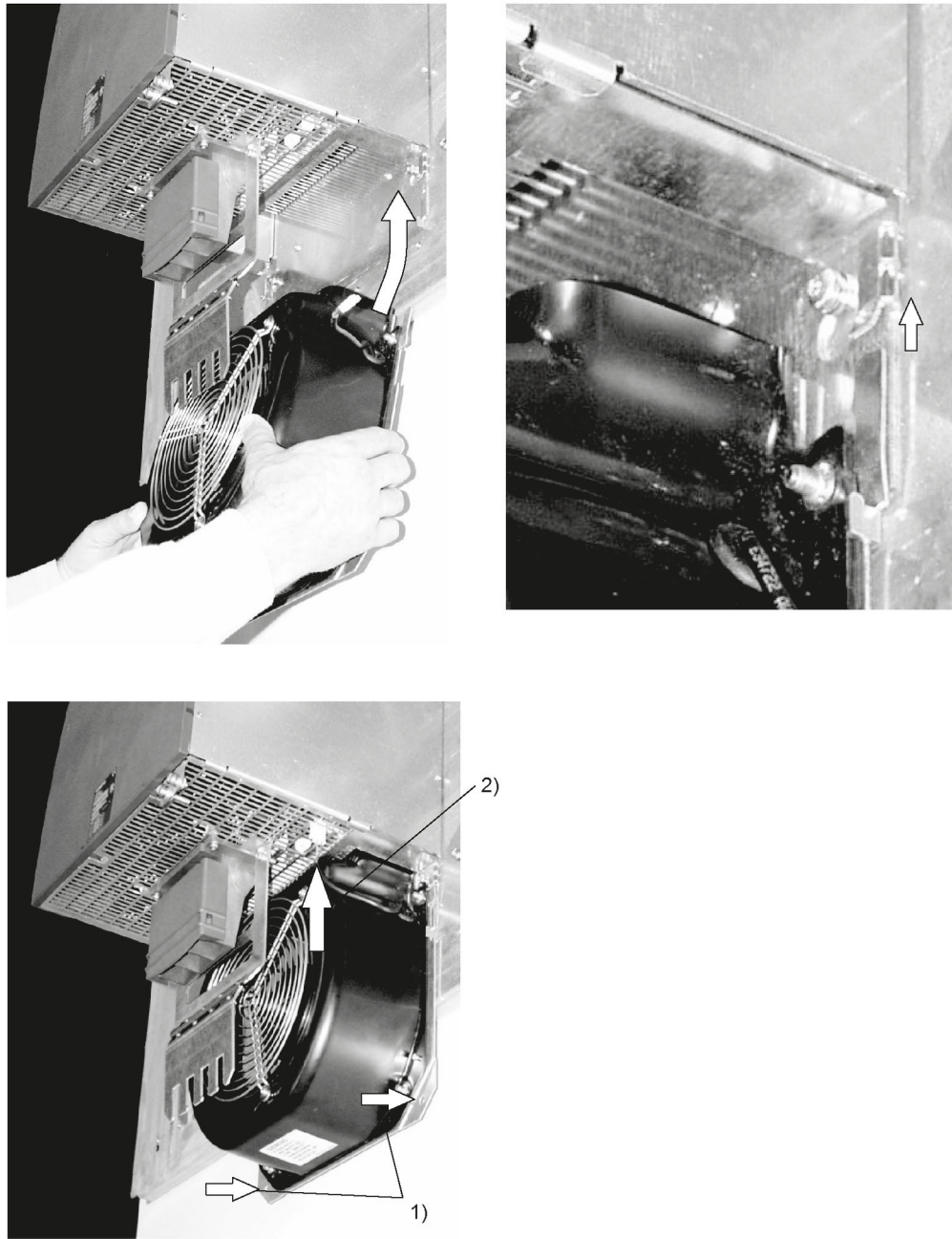

Figure 6-11 Mounting the fan for Motor Modules 132 A and 200 A

1. Fix the fan with M6 screws
Tightening torque: 6 Nm (53.1 lbf in)
2. Connect the fan power supply.

6.2.7 Technical data

6.2.7.1 Single Motor Modules

Table 6- 11 Technical data Single Motor Modules Booksize (3 to 30 A)

Internal air cooling	6SL3120-	1TE13-0AA. ¹⁾	1TE15-0AA. ¹⁾	1TE21-0AA. ¹⁾	1TE21-8AA. ¹⁾	1TE23-0AA.
Output current (at 600 V DC)						
Rated current (I_n)	A_{AC}	3	5	9	18	30
Base-load current (I_H)	A	2.6	4.3	7.7	15.3	25.5
Intermittent duty current (I_{S6}) 40%	A_{AC}	3.5	6	10	24	40
Peak current (I_{max})	A_{AC}	6	10	18	36	56
Output voltage	V_{AC}	0 ... 0.717 x DC-link voltage				
DC link current	A_{DC}	3.6	6	11	22	36
DC-link voltage (up to 2000 m above sea level)	V_{DC}	510 ... 720				
DC link capacitance	μF	110	110	110	220	705
Overvoltage trip	V_{DC}	820 \pm 2 %				
Undervoltage trip ²⁾	V_{DC}	380 \pm 2 %				
Electronics power supply	V_{DC}	24 (20.4 ... 28.8)				
Electronics current consumption at 24 V DC	A_{DC}	0.85	0.85	0.85	0.85	0.8
Current carrying capacity						
DC link busbars	A_{DC}	100				
Reinforced DC link busbars	A_{DC}	150				
24 V DC busbars	A_{DC}	20				
Unit rating³⁾						
Based on I_n (600 VDC; 4 kHz)	kW	1.6	2.7	4.8	9.7	16
Based on I_H	kW	1.4	2.3	4.1	8.2	13.7
Total power loss (including electronics losses, see Power loss tables (Page 734))	W	50.4	73.4	100.4	185.4	309.2
Max. pulse frequency						
without derating	kHz	4				
with derating	kHz	16				
Output frequency	Hz	0 ... 550				
Sound pressure level	dB(A)	< 60	< 60	< 60	< 60	< 60
Cooling method		Internal fan				
Cooling air requirement	m ³ /h	29.6	29.6	29.6	29.6	56
Max. permissible heat sink temperature	°C	75	75	79	82	85
Ventilation clearances above/below	mm	\geq 80				
Weight	kg	5	5	5	5	6.9

1) Applies only to Article numbers with "." = 0 ... 3

2) Default for 400 V line systems; undervoltage trip threshold can be reduced by up to 80 V and is adjusted to the parameterized rated voltage

3) Rated power of a typical standard induction motor at 400 V 3 AC.

Table 6- 12 Technical data Single Motor Modules Booksize (45 to 200 A)

Internal air cooling	6SL3120-	1TE24-5AA.	1TE26-0AA.	1TE28-5AA.	1TE31-3AA.	1TE32-0AA.
Output current (at 600 V DC)						
Rated current (I _n)	A _{AC}	45	60	85	132	200
Base-load current (I _H)	A	38	51	68	105	141
Intermittent duty current (I _{se})	A _{AC}	60	80	110	150	230
40%	A _{AC}	85	113	141	210	282
Peak current (I _{max})						
Output voltage	V _{AC}	0 ... 0.717 x DC-link voltage				
DC link current	A _{DC}	54	72	102	158	200
DC-link voltage (up to 2000 m above sea level)	V _{DC}	510 ... 720				
DC link capacitance	µF	1175	1410	1880	2820	3995
Overvoltage trip	V _{DC}	820 ± 2 %				
Undervoltage trip ¹⁾	V _{DC}	380 ± 2 %				
Electronics power supply	V _{DC}	24 (20.4 ... 28.8)				
Electronics current consumption at 24 V DC	A _{DC}	1.05	1.05	1.5	0.85	0.85
Current carrying capacity						
DC link busbars	A _{DC}	200	200	200	200	200
24 V DC busbars	A _{DC}	20	20	20	20	20
Unit rating²⁾						
Based on I _n (600 VDC; 4 kHz)	kW	24	32	46	71	107
Based on I _H	kW	21	28	37	57	76
Total power loss (including electronics losses, see Power loss tables (Page 734))	W	455.2	615.2	786	1270.4	2070.4
Max. pulse frequency without derating	kHz	4				
with derating	kHz	16				
Output frequency	Hz	0 ... 550				
Max. ambient temperature without derating	° C	40				
with derating	° C	55				
Sound pressure level	dB(A)	< 65	< 65	< 60	< 73	< 73
Cooling method (with fan)		Internal fan			Mounted fan	
Cooling air requirement	m ³ /h	112	112	160	520	520
Max. permissible heat sink temperature	°C	85	90	83	70	80 (70 % derating)
Ventilation clearances above/below	mm	≥ 80			≥ 80	
in front of the component	mm	---			≥ 50	
Weight	kg	9.4	9.8	14.6	20.7	21.6

1) Default for 400 V line systems; undervoltage trip threshold can be reduced by up to 80 V (exception: 132 A and 200 A Motor Modules) and is adjusted to the parameterized rated voltage.

2) Rated power of a typical standard induction motor at 400 V 3 AC.

6.2.7.2 Double Motor Modules

Table 6- 13 Technical data, Double Motor Modules Booksize (2 x 3 to 2 x 18 A)

Internal air cooling	6SL3120-	2TE13- 0AA. ¹⁾	2TE15- 0AA. ¹⁾	2TE21- 0AA. ¹⁾	2TE21- 8AA.
Output current (at 600 V DC)					
Rated current (I_n)	A_{AC}	2 x 3	2 x 5	2 x 9	2 x 18
Base-load current (I_H)	A	2 x 2.6	2 x 4.3	2 x 7.7	2 x 15.3
Intermittent duty current (I_{S6}) 40%	A_{AC}	2 x 3.5	2 x 6	2 x 10	2 x 24
Peak current (I_{max})	A_{AC}	2 x 6	2 x 10	2 x 18	2 x 36
Output voltage	V_{AC}	0 ... 0.717 x DC-link voltage			
DC link current	A_{DC}	7.2	12	22	43
DC-link voltage	V_{DC}	510 ... 720			
DC link capacitance	μF	220	220	220	705
Overvoltage trip	V_{DC}	820 \pm 2 %			
Undervoltage trip ²⁾	V_{DC}	380 \pm 2 %			
Electronics power supply	V_{DC}	24 (20.4 ... 28.8)			
Electronics current consumption at 24 V DC	A_{DC}	1.15	1.15	1.15	1.3
Current carrying capacity					
DC link busbars	A_{DC}	100			
Reinforced DC link busbars	A_{DC}	150			
24 V DC busbars	A	20			
Unit rating³⁾					
Based on I_n (600 VDC; 4 kHz)	kW	2 x 1.6	2 x 2.7	2 x 4.8	2 x 9.7
Based on I_H	kW	2 x 1.4	2 x 2.3	2 x 4.1	2 x 8.2
Total power loss (including electronics losses, see Power loss tables (Page 734))	W	97.6	132.6	187.6	351.2
Max. pulse frequency					
without derating	kHz	4			
with derating	kHz	16			
Output frequency	Hz	0 ... 550			
Sound pressure level	dB(A)	< 60	< 60	< 60	< 60
Cooling method		Internal fan			
Cooling air requirement	m ³ /h	29.6	29.6	29.6	56
Max. permissible heat sink temperature	°C	85	90	89	90
Ventilation clearances above/below	mm	\geq 80			
Weight	kg	5.3	5.3	5.5	6.8

1) Applies only to Article numbers with "." = 0 ... 3

2) Default for 400 V line systems; undervoltage trip threshold can be reduced by up to 80 V and is adjusted to the parameterized rated voltage

3) Rated power of a typical standard induction motor at 400 V 3 AC

6.2.7.3 Characteristics

Rated duty cycles Motor Modules Booksize

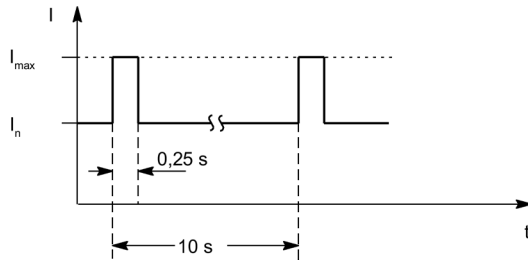

Figure 6-12 Duty cycle with initial load (for servo drives)

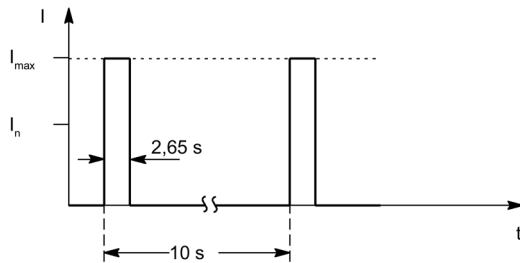

Figure 6-13 Duty cycle without initial load (for servo drives)

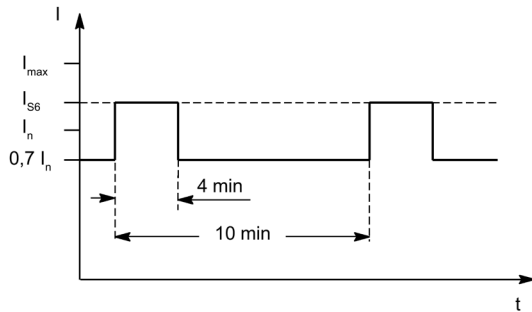

Figure 6-14 S6 duty cycle with initial load with a duty cycle duration of 600 s (for servo drives)

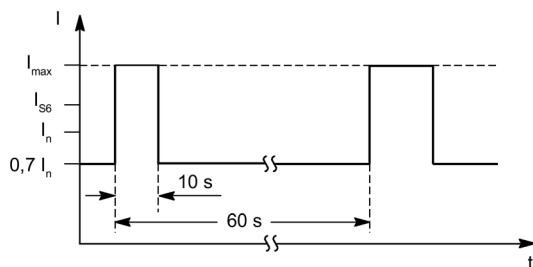

Figure 6-15 S6 duty cycle with initial load with a duty cycle duration of 60 s (for servo drives)

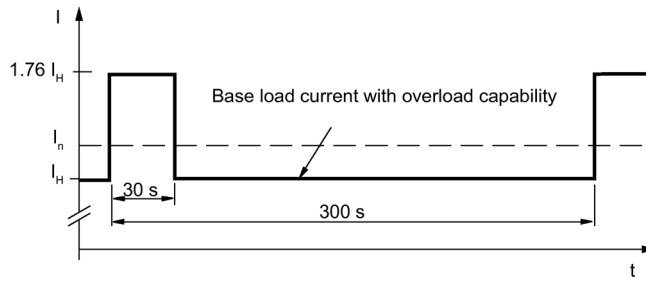

Figure 6-16 Duty cycle with 30 s overload for a duty cycle duration of 300 s

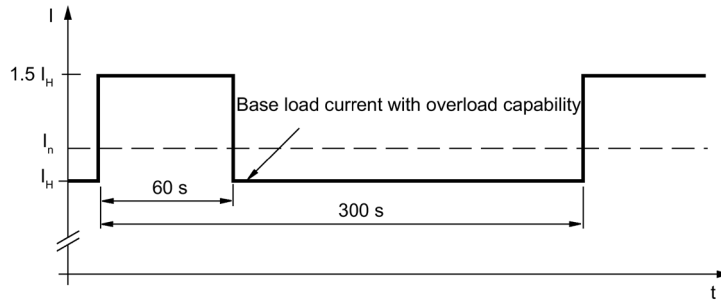

Figure 6-17 Duty cycle with 60 s overload for a duty cycle duration of 300 s

Derating characteristics for Motor Modules Booksize

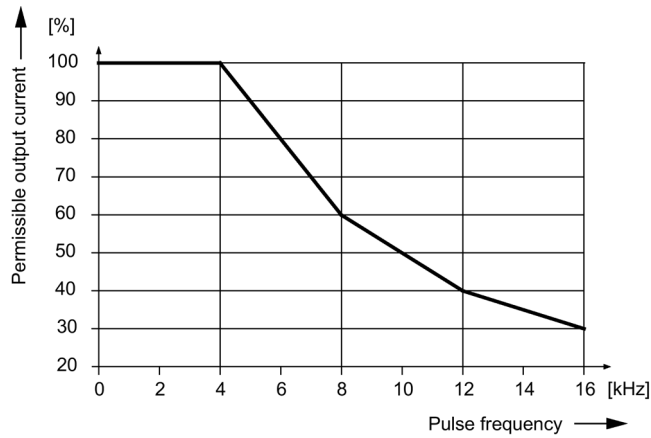

Figure 6-18 Output current as a function of the pulse frequency

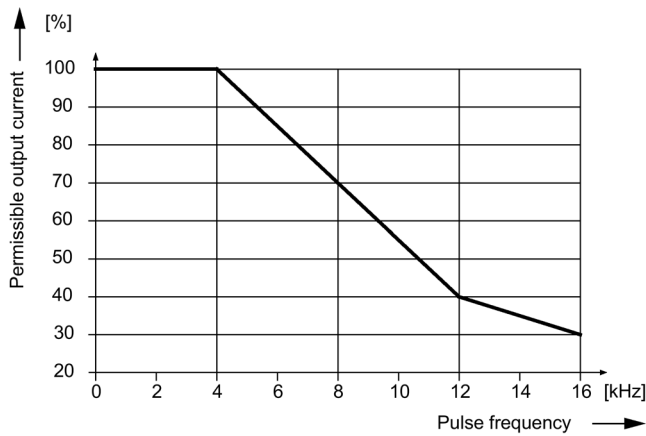

Figure 6-19 Output current as a function of the pulse frequency for 200 A Motor Modules (applies from Article number 6SL312.-1TE32-0AA4)

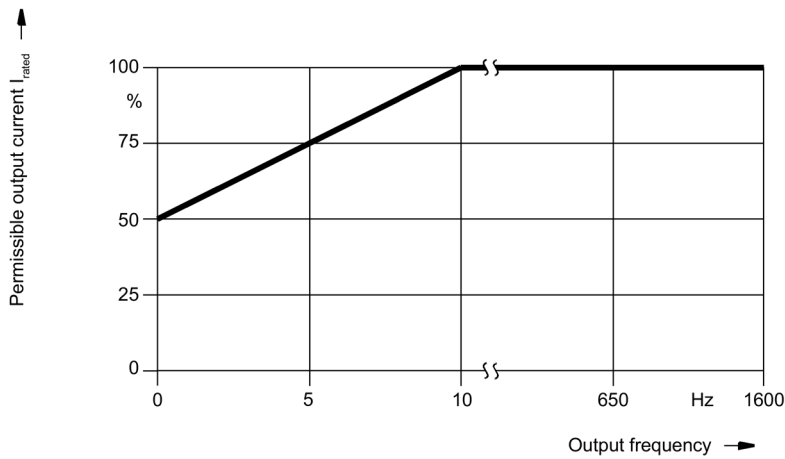

Figure 6-20 Output current at low frequencies

Dimensioning notes:

- A current derating is only applicable for output frequencies < 10 Hz.
- Current derating should be taken into account if the percentage time of operation at frequencies < 10 Hz is more than 2 % of the daily total operating time.
- Also during load cycles, the current specified here must not be exceeded.
- When quickly passing through frequencies 0 to 10 Hz, derating does not have to be taken into account (e.g. for positioning applications).

Note

Information about derating the output current as a function of the ambient temperature and installation altitude is provided in Chapter "System data (Page 42)".

6.2.8 Technical data for Motor Modules Booksize with 300% overload

6.2.8.1 Single Motor Modules (300% overload)

Table 6- 14 Technical data Single Motor Modules Booksize (3 to 18 A) with 3-fold overload

Internal air cooling	6SL3120–	1TE13-0AA4	1TE15-0AA4	1TE21–0AA4	1TE21–8AA4
Output current (at 600 V DC)					
Rated current (I_n)	A_{AC}	3	5	9	18
Base-load current (I_H)	A	2.6	4.3	7.7	15.3
Intermittent duty current (I_{S6}) 40%	A_{AC}	3.5	6	10	24
Peak current (I_{max})	A_{AC}	9	15	27	54
Output voltage	V_{AC}	0 ... 0.717 x DC-link voltage			
DC-link current	A_{DC}	3.6	6	11	22
DC-link voltage (up to 2000 m above sea level)	V_{DC}	510 ... 720			
DC link capacitance	μF	110	110	110	220
Overvoltage trip	V_{DC}	820 \pm 2 %			
Undervoltage trip ¹⁾	V_{DC}	380 \pm 2 %			
Electronics power supply	V_{DC}	24 (20.4 ... 28.8)			
Electronics current consumption at 24 V DC	A_{DC}	0.85	0.85	0.85	0.85
Current carrying capacity					
DC link busbars	A_{DC}	100			
Reinforced DC link busbars	A_{DC}	150			
24 V DC busbars	A_{DC}	20			
Unit rating²⁾					
Based on I_n (600 VDC; 4 kHz)	kW	1.6	2.7	4.8	9.7
Based on I_H	kW	1.4	2.3	4.1	8.2
Total power loss (including electronics losses, see Power loss tables (Page 734))	W	50.4	73.4	100.4	185.4
Max. pulse frequency					
without derating	kHz	4			
with derating	kHz	16			
Output frequency	Hz	0 ... 550			
Sound pressure level	dB(A)	< 60			
Cooling method		Internal fan			
Cooling air requirement	m ³ /h	29.6			
Max. permissible heat sink temperature	°C	74	74	75	90
Ventilation clearances above/below	mm	\geq 80			
Weight	kg	5	5	5	5

1) Default for 400 V line systems; undervoltage trip threshold can be reduced by up to 80 V and is adjusted to the parameterized rated voltage

2) Rated power of a typical standard induction motor at 400 V 3 AC

Note

Operation of 18 A Single Motor Modules with 3-fold overload connected to a 16 kW Line Module

The maximum power of a 16 kW Line Module is not sufficient for operating 18 A Single Motor Modules at their peak current.

- Take the motor power into consideration if you wish to operate an 18 A Single Motor Module on a 16 kW Line Module. Depending on the operating state, the power consumption of these Single Motor Modules can be > 35 kW, and it may be necessary to install a Line Module with a higher power rating for applications such as these.

6.2.8.2 Double Motor Modules (300% overload)

Table 6- 15 Technical data Double Motor Modules Booksize (2 x 3 to 2 x 9 A) with 3-fold overload

Internal air cooling	6SL3120-	2TE13-0AA4	2TE15-0AA4	2TE21-0AA4
Output current (at 600 V DC)				
Rated current (I _n)	A _{AC}	2 x 3	2 x 5	2 x 9
Base-load current (I _H)	A	2 x 2.6	2 x 4.3	2 x 7.7
Intermittent duty current (I _{s6}) 40%	A _{AC}	2 x 3.5	2 x 6	2 x 10
Peak current (I _{max})	A _{AC}	2 x 9	2 x 15	2 x 27
Output voltage	V _{AC}	0 ... 0.717 x DC-link voltage		
DC-link current	A _{DC}	7.2	12	22
DC-link voltage (up to 2000 m above sea level)	V _{DC}	510 ... 720		
DC link capacitance	µF	220		
Overvoltage trip	V _{DC}	820 ± 2 %		
Undervoltage trip ¹⁾	V _{DC}	380 ± 2 %		
Electronics power supply	V _{DC}	24 (20.4 ... 28.8)		
Electronics current consumption at 24 V DC	A _{DC}	1.15		
Current carrying capacity				
DC link busbars	A _{DC}	100		
Reinforced DC link busbars	A _{DC}	150		
24 V DC busbars	A	20		
Unit rating²⁾				
Based on I _n (600 VDC; 4 kHz)	kW	2 x 1.6	2 x 2.7	2 x 4.8
Based on I _H	kW	2 x 1.4	2 x 2.3	2 x 4.1
Total power loss (including electronics losses, see Power loss tables (Page 734))	W	97.6	132.6	187.6
Max. pulse frequency				
without derating	kHz	4		
with derating	kHz	16		
Output frequency	Hz	0 ... 550		

Internal air cooling	6SL3120-	2TE13-0AA4	2TE15-0AA4	2TE21-0AA4
Sound pressure level	dB(A) < 60			
Cooling method	Internal fan			
Cooling air requirement	m ³ /h 29.6			
Max. permissible heat sink temperature	°C	84	78	92
Ventilation clearances above/below	mm ≥ 80			
Weight	kg	5.3	5.3	5.5

- 1) Default for 400 V line systems; undervoltage trip threshold can be reduced by up to 80 V and is adjusted to the parameterized rated voltage
- 2) Rated power of a typical standard induction motor at 400 V 3 AC.

Note

Disturbance of the 2 x 9 A Double Motor Module with 3-fold overload on a 16 kW Line Module

The maximum output of a 16 kW Line Module is not sufficient for the operation of a 2 x 9 A Double Motor Module with 3-fold overload.

- Do NOT operate a 2 x 9 A Double Motor Module with a 16 kW Line Module with 3-fold overload (i.e. only operate a 2 x 9 A Double Motor Module with a 16 kW Line Module, if the maximum current is limited to 2 x I_{rated}).
- Use at least a 36 kW Active Line Module or Smart Line Module for operation with 3-fold overload.

6.2.8.3 Characteristics for Motor Modules Booksize with 300% overload

Rated duty cycles Motor Modules Booksize with 300% overload

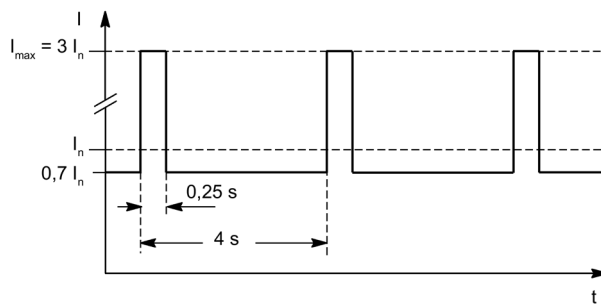

Figure 6-21 Peak current duty cycle with initial load (300% overload)

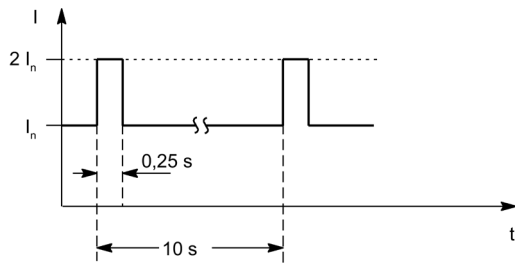

Figure 6-22 Duty cycle with initial load

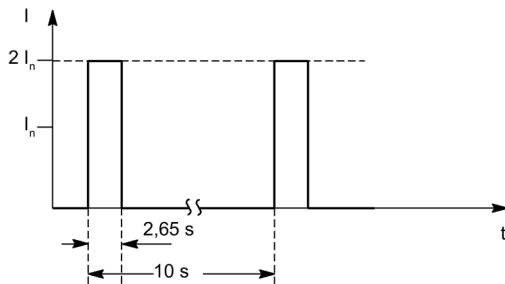

Figure 6-23 Duty cycle without initial load

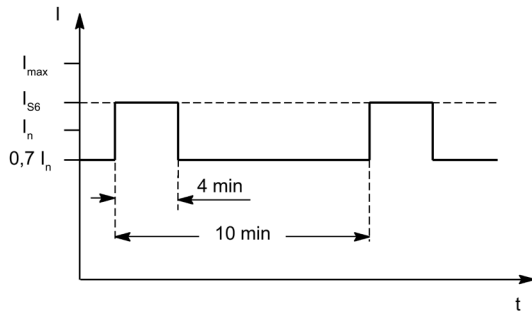

Figure 6-24 S6 duty cycle with initial load for a duty cycle duration of 600 s

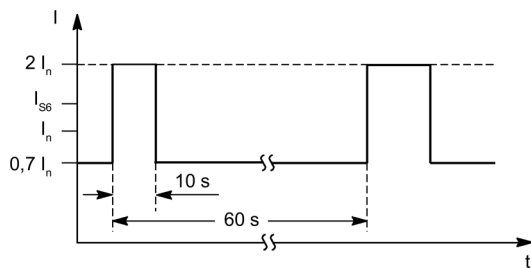

Figure 6-25 S6 duty cycle with initial load for a duty cycle duration of 60 s

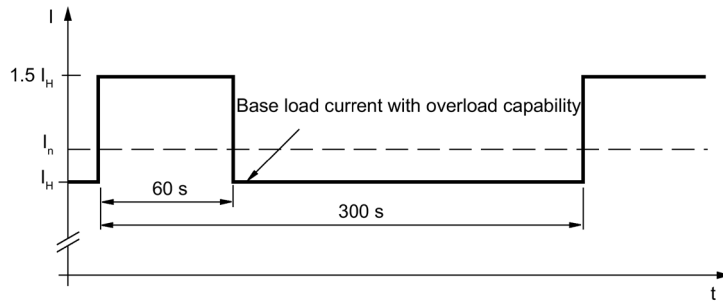

Figure 6-26 Duty cycle with 60 s overload for a duty cycle duration of 300 s

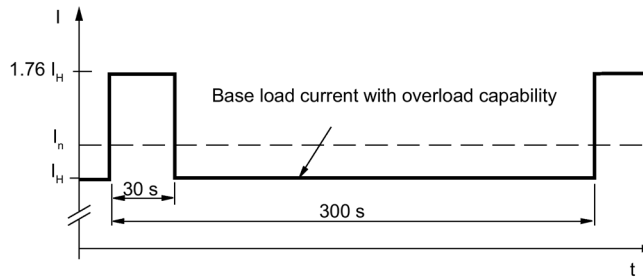

Figure 6-27 Duty cycle with 30 s overload for a duty cycle duration of 300 s

Derating characteristics for Motor Modules Booksize with 300% overload

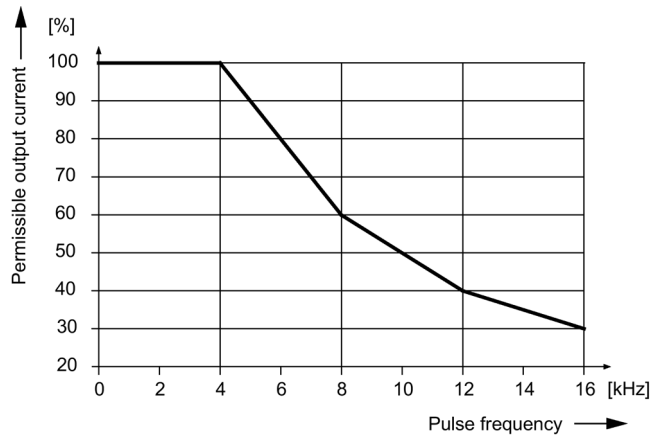

Figure 6-28 Output current as a function of the pulse frequency

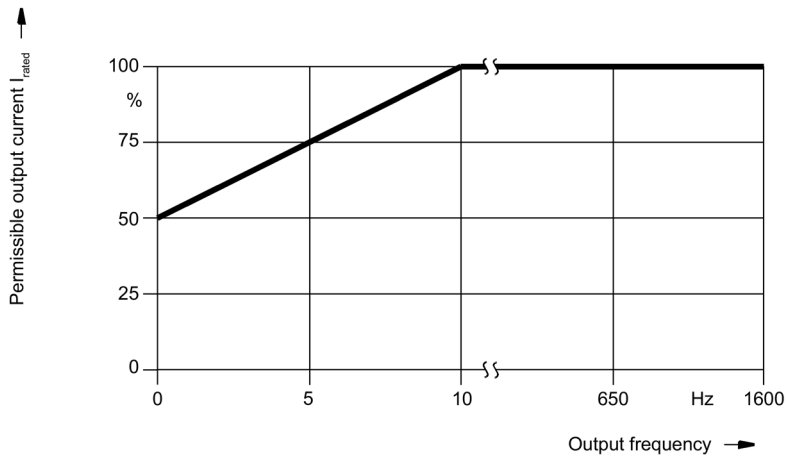

Figure 6-29 Output current at low frequencies

Dimensioning notes:

- A current derating is only applicable for output frequencies < 10 Hz.
- Current derating should be taken into account if the percentage time of operation at frequencies < 10 Hz is more than 2 % of the daily total operating time.
- Also during load cycles, the current specified here must not be exceeded.
- When quickly passing through frequencies 0 to 10 Hz, derating does not have to be taken into account (e.g. for positioning applications).

Note

Information about derating the output current as a function of the ambient temperature and installation altitude is provided in Chapter "System data (Page 42)".

6.3 Motor Module with external air cooling

6.3.1 Description

A Motor Module with external cooling is a power unit (inverter) that provides the power for the connected motors. Power is supplied by the DC link of the drive unit. A Motor Module must be connected to a Control Unit via DRIVE-CLiQ. The open-loop and closed-loop control functions for the Motor Module are stored in the Control Unit.

Motor Modules with external air cooling are offered as Single Motor Modules and Double Motor Modules. One motor can be connected to Single Motor Modules and 2 motors can be connected to Double Motor Modules.

External air cooling uses the "through-hole" method. The power unit and its heat sink can be inserted in a rectangular knockout at the rear of the control cabinet and mounted with a seal. The heat sink fins and the fan (included in the scope of delivery) project beyond the rear of the control cabinet and the heat is dissipated outside the control cabinet or in a separate air duct.

6.3.2 Interface description

6.3.2.1 Overview

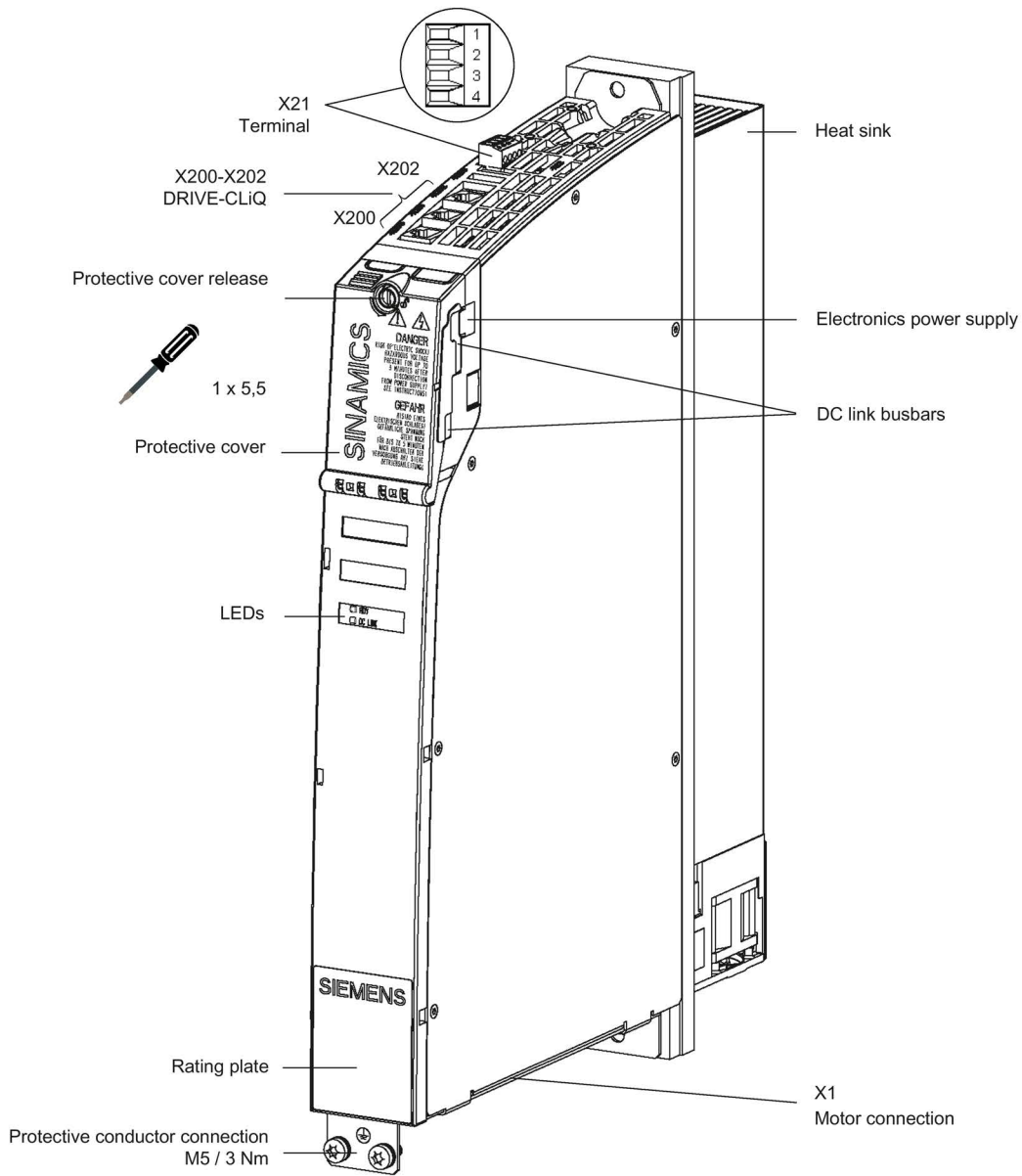

Figure 6-30 Interface overview, Single Motor Module Booksize with external air cooling (example: 5 A)

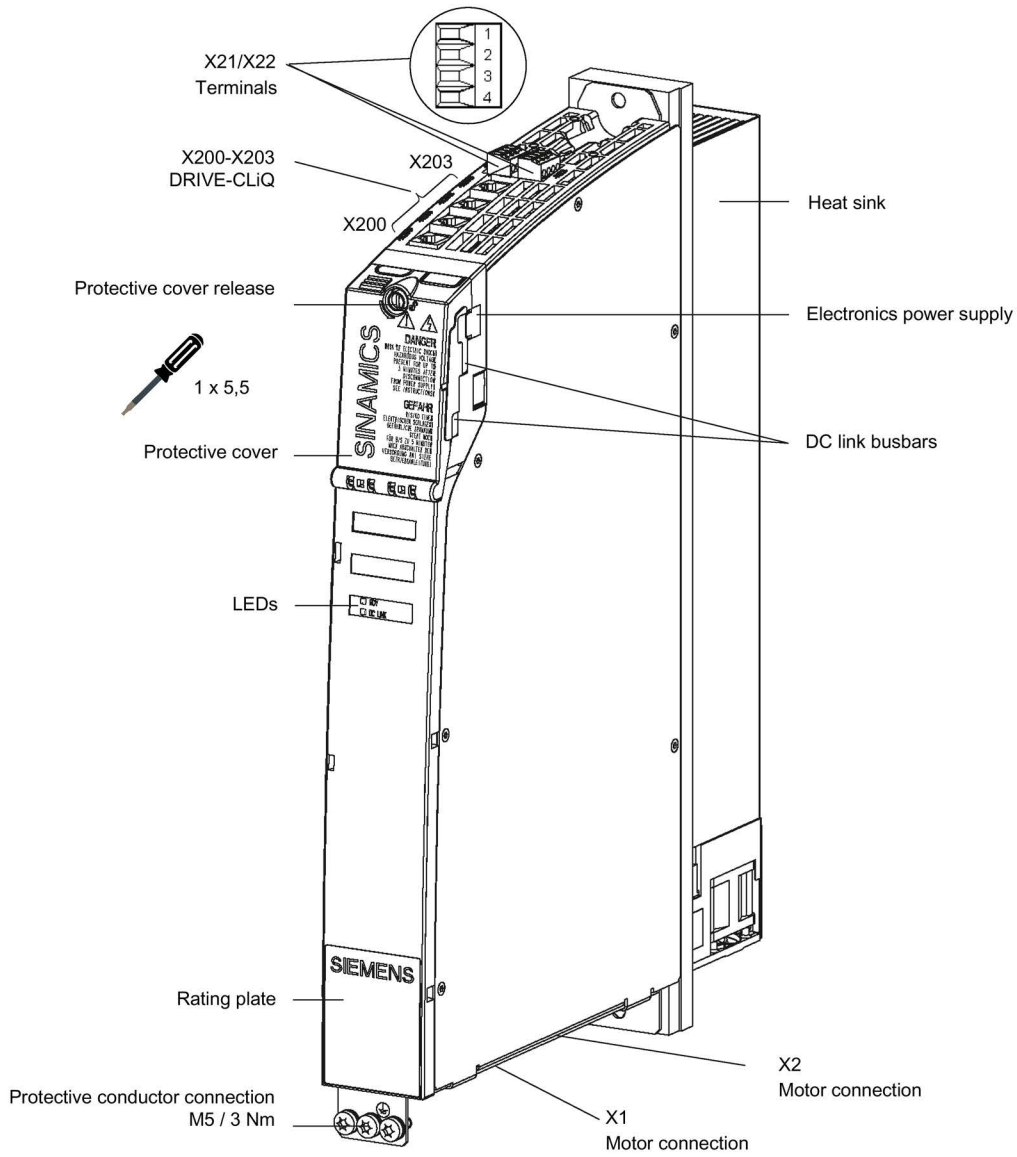

Figure 6-31 Interface overview, Double Motor Module Booksize with external air cooling (example: 2 x 5 A)

6.3.2.2 Motor and brake connection

Table 6- 16 X1/X2 motor and brake connections for Single Motor Modules 3 A to 30 A and Double Motor Modules 2 x 3 A to 2 x 18 A

	Terminal	Technical data	
	U (U2)	Motor connection	
	V (V2)		
	W (W2)		
	+ (BR+)	Brake connection:	
	- (BR-)	Supply voltage: 24 V DC ±10% Max. load current: 2 A Minimum load current: 0.1 A	
	Protective conductor connection	Single Motor Modules 3 ... 30 A: Threaded hole M5 / 3 Nm (26.6 lbf in) ¹⁾	
		Double Motor Modules 2 x 3 ... 2 x 18 A: Threaded hole M5 / 3 Nm (26.6 lbf in) ¹⁾	
¹⁾ For ring cable lugs without insulation (Page 710)			

Table 6- 17 X1 motor connection and X11 brake connection for Single Motor Modules 45 A to 200 A

	Terminal	Technical data
	U2	45 ... 60 A: Threaded bolts M6 / 6 Nm (53.1 lbf in) ¹⁾ 85 A: Threaded bolts M8 / 13 Nm (115 lbf in) ¹⁾ 132 ... 200 A: Threaded bolts M8 / 13 Nm (115 lbf in) ¹⁾
	V2	
	W2	
	Protective conductor connection	45 ... 60 A: Threaded bolts for motor cables: M6 / 6 Nm (53.1 lbf in) ¹⁾ Threaded hole for protective conductor: M6 / 6 Nm (53.1 lbf in) ¹⁾
		85 A: Threaded bolts for motor cables: M8 / 13 Nm (115 lbf in) ¹⁾ Threaded hole for protective conductor: M6 / 6 Nm (53.1 lbf in) ¹⁾ 132 ... 200 A: Threaded bolts for motor cables: M8 / 13 Nm (115 lbf in) ¹⁾ Threaded hole for protective conductor: M8 / 13 Nm (115 lbf in) ¹⁾
	+ (BR+)	X11 brake connector²⁾: Supply voltage: 24 V DC ±10 % Max. load current: 2 A Minimum load current: 0.1 A Type: Spring-loaded terminal 2 (Page 708) The brake connector is part of the prefabricated cable.
	- (BR-)	
¹⁾ For ring cable lugs without insulation (Page 710) ²⁾ The circuit for protecting the brake against overvoltage is integrated in the Motor Module and does not need to be installed externally.		

Motor holding brake connection

To ensure reliable opening of the motor holding brake, it requires a 24 V ± 10% voltage supply at the motor connection. It must be taken into account that voltage dips can occur along the supply cable.

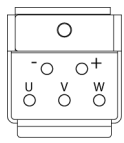
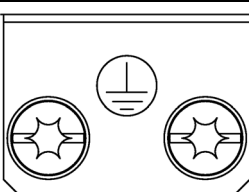
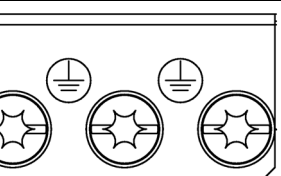
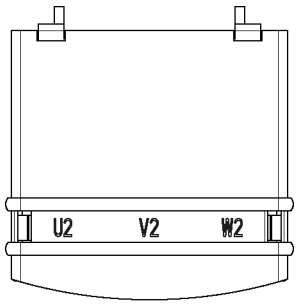
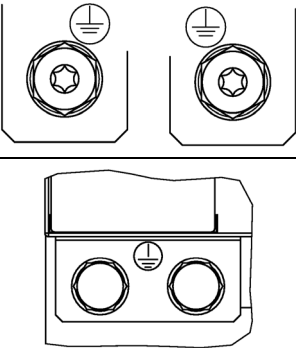
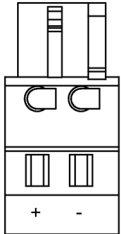
- Use a Control Supply Module or a regulated DC power supply, whose setpoint is set to 26 V.
- Use supply cables with a minimum cross-section of 1.5 mm² (AWG 16) and a maximum length of 100 m.

Note

Protective circuit against overvoltage

The Motor Modules have an integrated overvoltage protection circuit for the motor holding brake. External protective circuits are not required.

 **WARNING**

High contact voltage on brake cables

For motor cables with integrated brake cable, when the motor is operated, the motor can charge the brake cable up to hazardous voltage levels. Coming into contact with the conductors or the shield of the brake cable can result in death or serious injury.

- Use motor cables with separate, shielded brake cables and connect the shield of the brake cable at both ends.

NOTICE

Premature wear of the motor holding brake when operated outside its permissible voltage range

Operating the motor holding brake outside its permissible voltage range at the motor connection will damage the brake.

- Ensure that the motor holding brake is only operated within its permissible voltage range.

NOTICE

Faulty brake function due to inadmissible wear

Inadmissible wear means that the braking function can no longer be guaranteed.

- Comply with the predefined Emergency Stop characteristics.
- Avoid repeated brief acceleration of the motor against a holding brake that is still closed. Consider the operating times of the brakes and the relays in the drive control and enable.

Note

The total length of the power cables (motor feeder cables and DC link cables) must not exceed the values listed in Chapter "Combination options, Line Modules with line reactors and line filters (Page 120)".

Note

The motor brake must be connected via connector X11. It is not permitted to directly connect the cable BR- to the electronics ground M.

6.3.2.3 X12 fan connection

The Motor Modules 132 A and 200 A are equipped with an interface to connect a sub-chassis fan. The interface is located on the underside of the Motor Module.

Table 6- 18 X12 fan connection

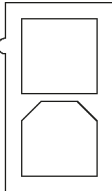
	Terminal	Function	Technical data
	1	Fan connection +	Voltage 48 V DC for the supplied fan
	2	Fan connection -	

6.3.2.4 X21/X22 EP terminals/temperature sensor

Table 6- 19 X21/X22 EP terminals / temperature sensor

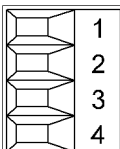
	Terminal	Function	Technical data
	1	+ Temp	Temperature sensors: KTY84-1C130 / PT1000 / PTC / bimetallic switch with NC contact
	2	- Temp	
	3	EP +24 V (pulse enable)	Supply voltage: 24 V DC (20.4 ... 28.8 V) Current consumption, typical: 4 mA at 24 V Isolated input The pulse inhibit function is only available when the "Safety Integrated Basic Functions via onboard terminals" software is enabled.
	4	EP M1 (enable pulses)	
Type: Screw terminal 1 (Page 708)			

EP terminals

Parameters p9651 and p9851 are used to set the filter times for debouncing terminals X21.3 and X21.4, as well as X22.3 and X22.4 (see SINAMICS S120/S150 List Manual). Additional parameter settings are also required in order to prevent discrepancy errors when performing bit pattern tests (light/dark tests). For comprehensive information, see the SINAMICS S120 Safety Integrated Function Manual, Section "Controlling the safety functions".

Note

Function of the EP terminals

The function of the EP terminals for pulse inhibit is only available if the "Safety Integrated Basic Functions via onboard terminals" software is enabled.

Temperature sensor connection

NOTICE
Damage to motor in the event of incorrectly connected KTY temperature sensor
A KTY temperature sensor connected with incorrect polarity cannot detect if the motor overheats. Overheating can cause damage to the motor.
<ul style="list-style-type: none"> • Connect the KTY temperature sensor with the correct polarity.

Note

The temperature sensor input is not needed if the motors feature an integrated DRIVE-CLiQ interface or if temperature values are detected by means of a different module (SMC, SME, TM).



! WARNING
Electric shock in the event of voltage flashovers at the temperature sensor
Voltage flashovers in the signal electronics can occur in motors without safe electrical separation of the temperature sensors.
<ul style="list-style-type: none"> • Use temperature sensors that comply with the specifications relating to protective separation. • If safe electrical separation cannot be guaranteed (for linear motors or third-party motors, for example), use a Sensor Module External (SME120 or SME125) or Terminal Module TM120.

6.3.2.5 X200-X203 DRIVE-CLiQ interface

Table 6- 20 X200-X202: DRIVE-CLiQ interfaces for Single Motor Modules
X200-X203: DRIVE-CLiQ interfaces for Double Motor Modules

	Pin	Name	Technical data
	1	TXP	Transmit data +
	2	TXN	Transmit data -
	3	RXP	Receive data +
	4	Reserved, do not use	-
	5	Reserved, do not use	-
	6	RXN	Receive data -
	7	Reserved, do not use	-
	8	Reserved, do not use	-
	A	+ (24 V)	Power supply
	B	M (0 V)	Electronics ground

The blanking covers for the DRIVE-CLiQ interfaces are included in the scope of delivery.

Blanking cover (50 pcs.) Article number: 6SL3066-4CA00-0AA0

6.3.3 Connection examples

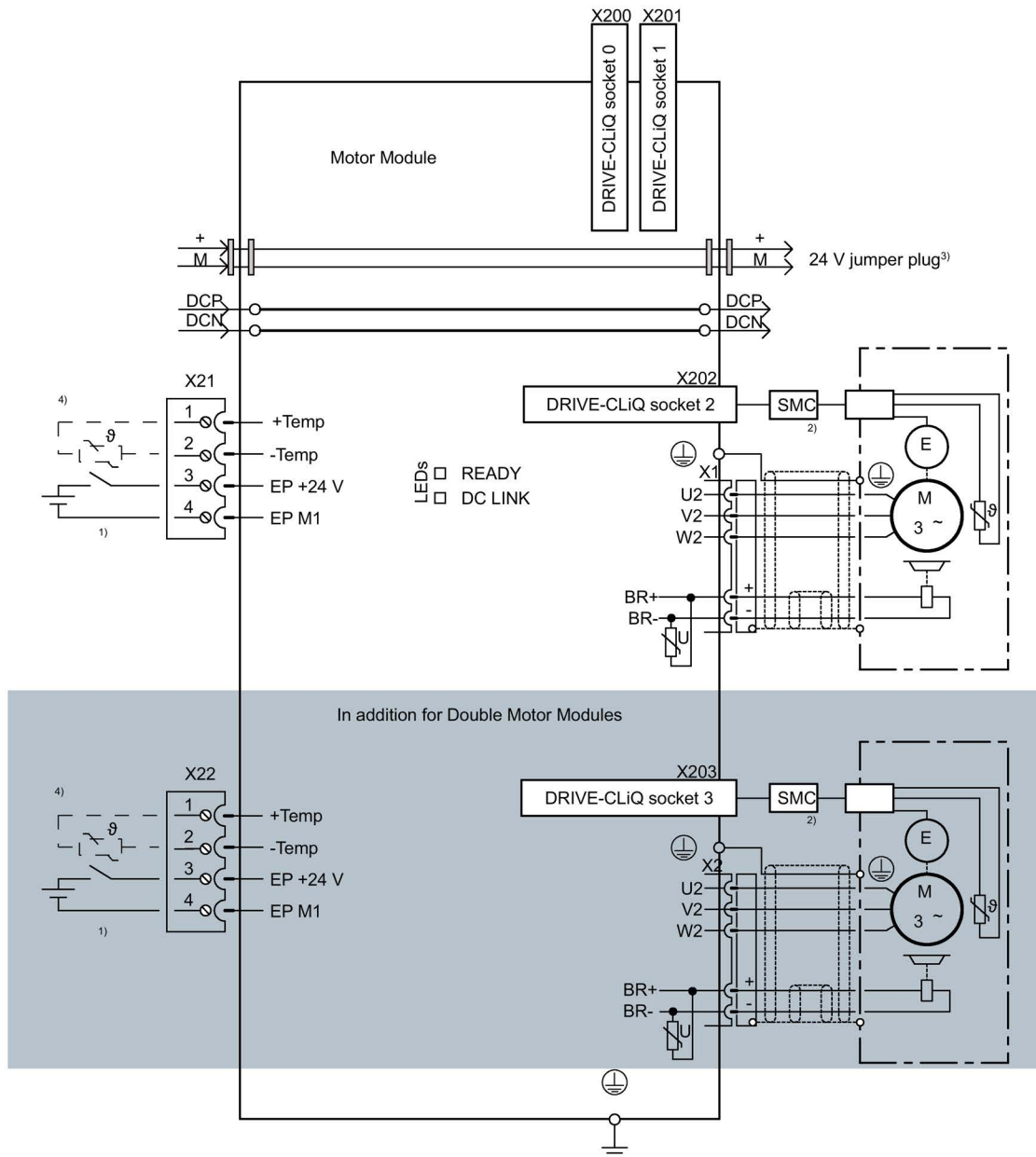

- ¹⁾ Required for safety
- ²⁾ SMC required for motors without DRIVE-CLiQ interface
- ³⁾ 24 V to the next module
- ⁴⁾ Optional, e.g. for motor without encoder

Figure 6-32 Connection example of Motor Modules 3 A to 30 A and Double Motor Modules 2 x 3 A to 2 x 18 A

6.3 Motor Module with external air cooling

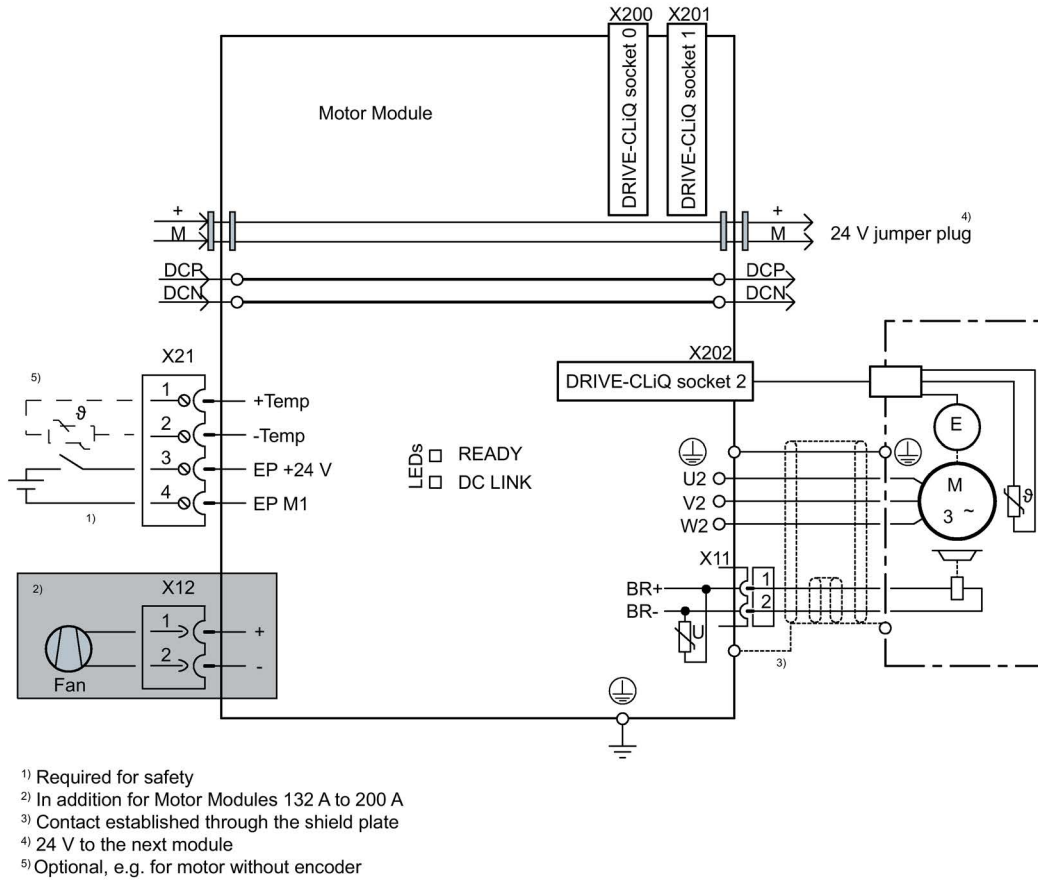

Figure 6-33 Example connection of Single Motor Modules 45 A to 200 A

6.3.4 Meaning of LEDs

Table 6- 21 Meaning of the LEDs on the Motor Module

Status		Description, cause	Remedy
RDY	DC LINK		
Off	Off	The electronics power supply is missing or outside the permissible tolerance range.	–
Green	-- ¹⁾	The component is ready for operation. Cyclic DRIVE-CLiQ communication is taking place.	–
	Orange	The component is ready for operation. Cyclic DRIVE-CLiQ communication is taking place. The DC link voltage is present.	–
	Red	The component is ready for operation. Cyclic DRIVE-CLiQ communication is taking place. The DC link voltage is outside the permissible tolerance range.	Check the line supply voltage.
Orange	Orange	DRIVE-CLiQ communication is being established.	–
Red	-- ¹⁾	This component has at least one fault.	Resolve and acknowledge the fault.
Green/red (0.5 Hz)	-- ¹⁾	Firmware is being downloaded.	–
Green/red (2 Hz)	-- ¹⁾	Firmware download has been completed. The system waits for POWER ON.	Carry out a POWER ON.
Green/orange or red/orange	-- ¹⁾	Component recognition via LED is activated ²⁾ . Note: Both options depend on the LED status when component recognition is activated.	–

¹⁾ Irrespective of the status of the LED "DC LINK"

²⁾ For information about activating the parameter "Recognition via LED", see SINAMICS S120/S150 List Manual

6.3.5 Dimension drawings

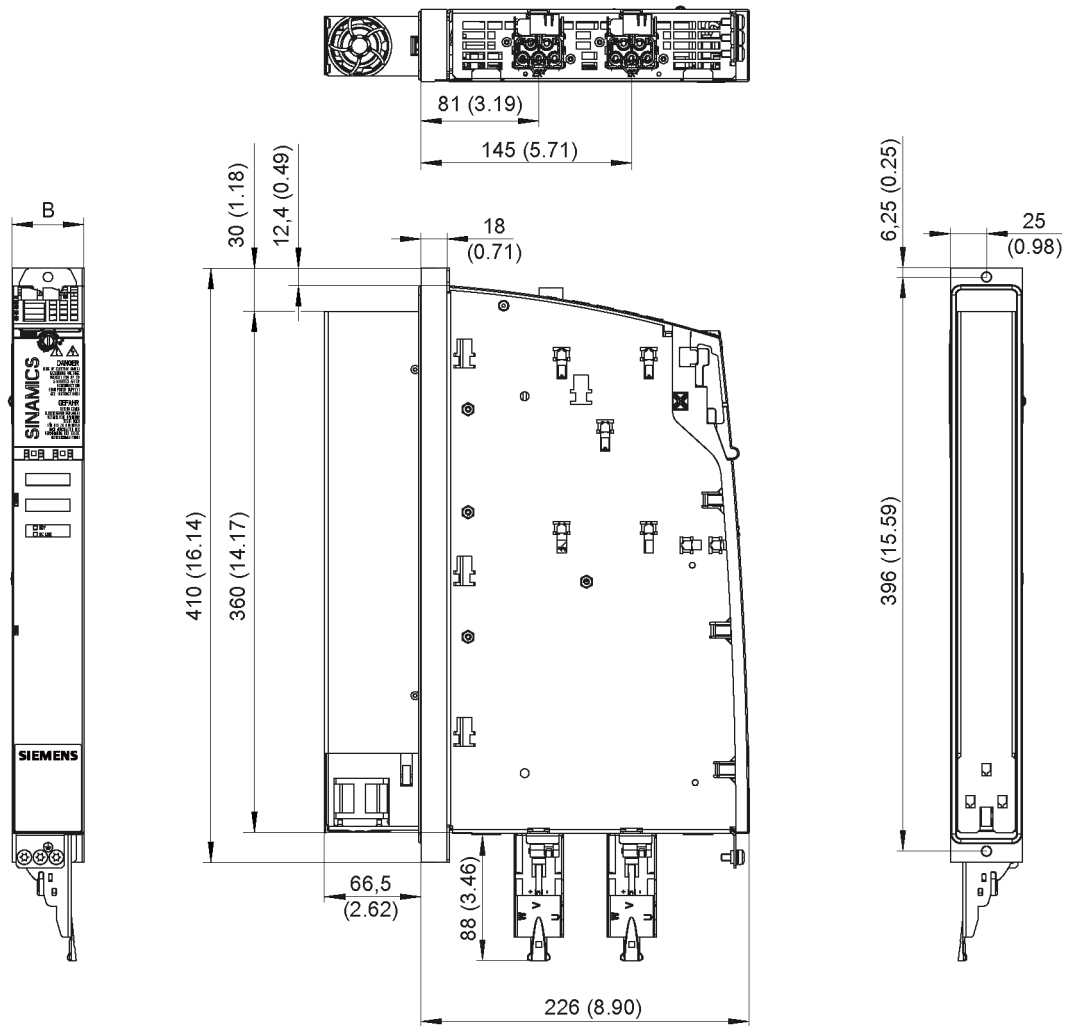

Figure 6-34 Dimension drawing of 3 A to 18 A and 2 x 3 A to 2 x 9 A Motor Modules Booksize with external air cooling, all dimensions in mm and (inches); example: 2 x 5 A Double Motor Module

Table 6- 22 Dimensions of 3 A to 18 A and 2 x 3 A to 2 x 9 A Motor Modules Booksize with external air cooling

Motor Module	Article No.	W [mm] (inch)
Single Motor Module 3 A	6SL3121-1TE13-0AA.	50 (1.97)
Single Motor Module 5 A	6SL3121-1TE15-0AA.	
Single Motor Module 9 A	6SL3121-1TE19-0AA.	
Single Motor Module 18 A	6SL3121-1TE21-8AA.	
Double Motor Module 2 x 3 A	6SL3121-2TE13-0AA.	
Double Motor Module 2 x 5 A	6SL3121-2TE15-0AA.	
Double Motor Module 2 x 9 A	6SL3121-2TE21-0AA.	

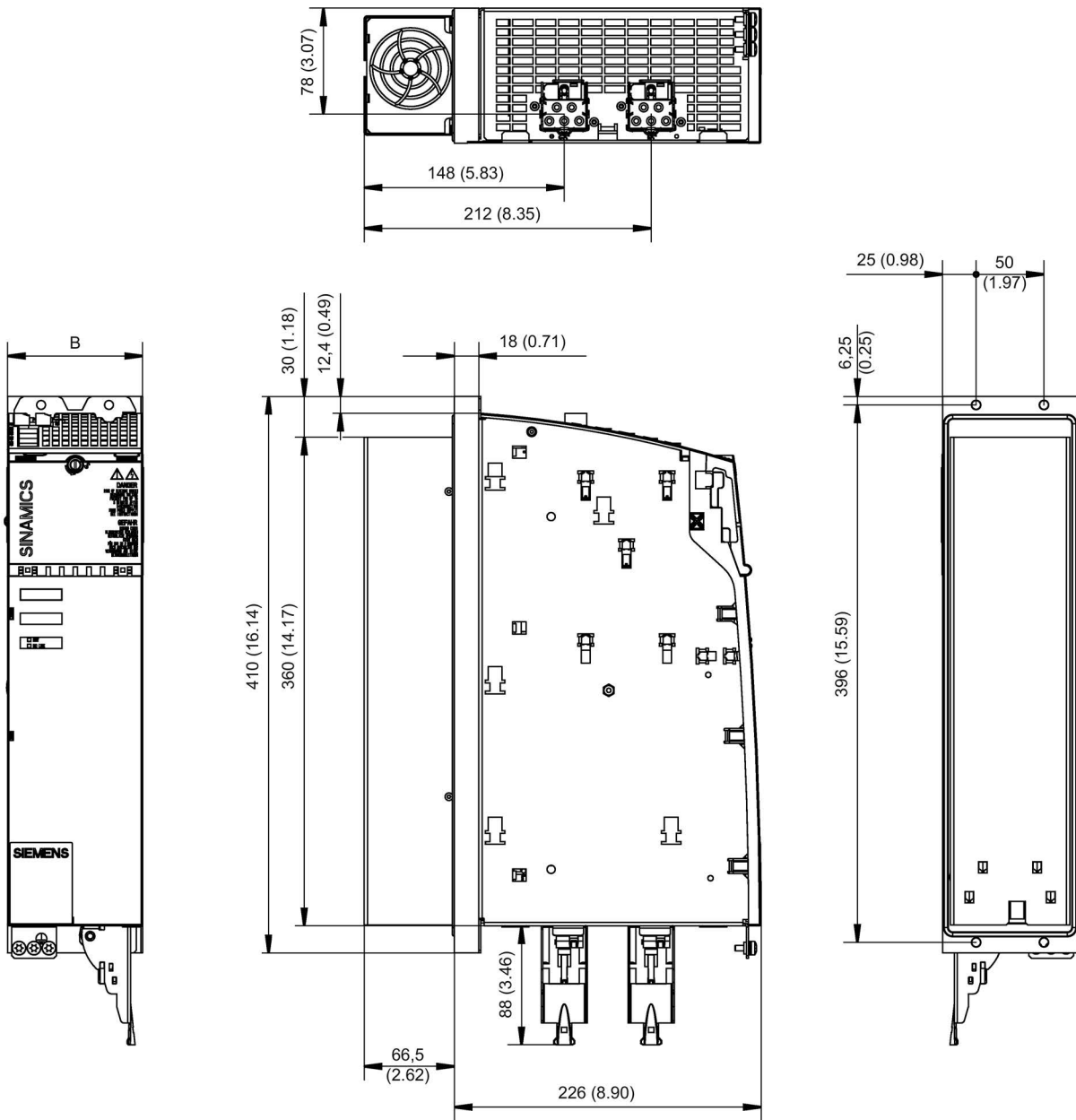

Figure 6-35 Dimension drawing of 30 A and 2 x 18 A Motor Modules Booksize with external air cooling, all dimensions in mm and (inches); example: 2 x 18 A Double Motor Module

Table 6- 23 Dimensions of 30 A and 2 x 18 A Motor Modules Booksize with external air cooling

Motor Module	Article No.	W [mm] (inch)
Single Motor Module 30 A	6SL3121-1TE23-0AA.	100 (3.94)
Double Motor Module 2 x 18 A	6SL3121-2TE21-8AA.	

6.3 Motor Module with external air cooling

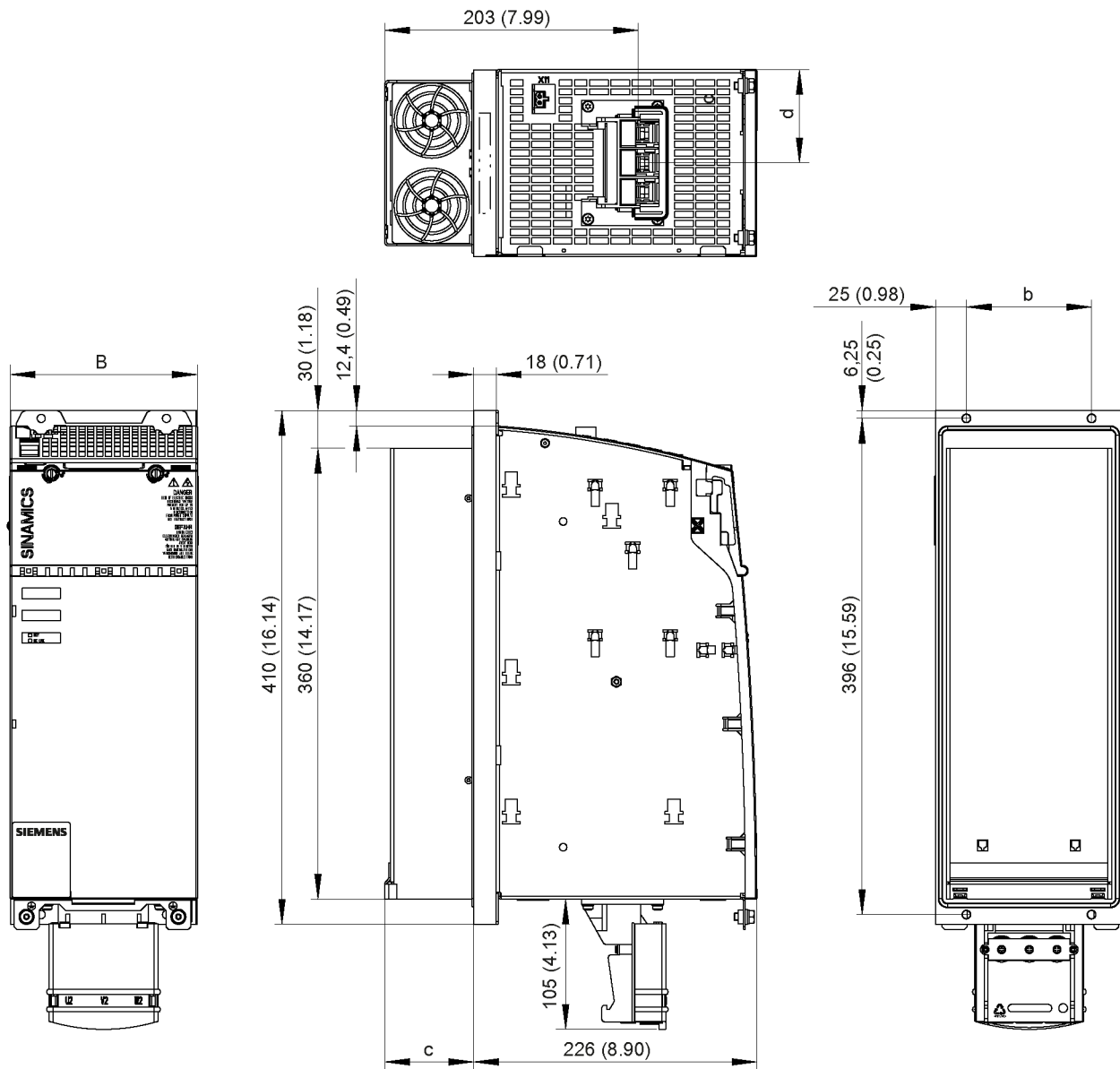

Figure 6-36 Dimension drawing of 45 A, 60 A and 85 A Motor Modules Booksize with external air cooling, all dimensions in mm and (inches); example 45 A

Table 6- 24 Dimensions of 45 A, 60 A and 85 A Motor Modules Booksize with external air cooling

Motor Module	Article No.	W [mm] (inch)	b [mm] (inch)	c [mm] (inch)	d [mm] (inch)
Single Motor Module 45 A	6SL3121-1TE24-5AA.	150 (5.91)	100 (3.94)	71 (2.80)	75 (2.95)
Single Motor Module 60 A	6SL3121-1TE26-0AA.				
Single Motor Module 85 A	6SL3121-1TE28-5AA.	200 (7.87)	150 (5.91)	92 (3.62)	100 (3.94)

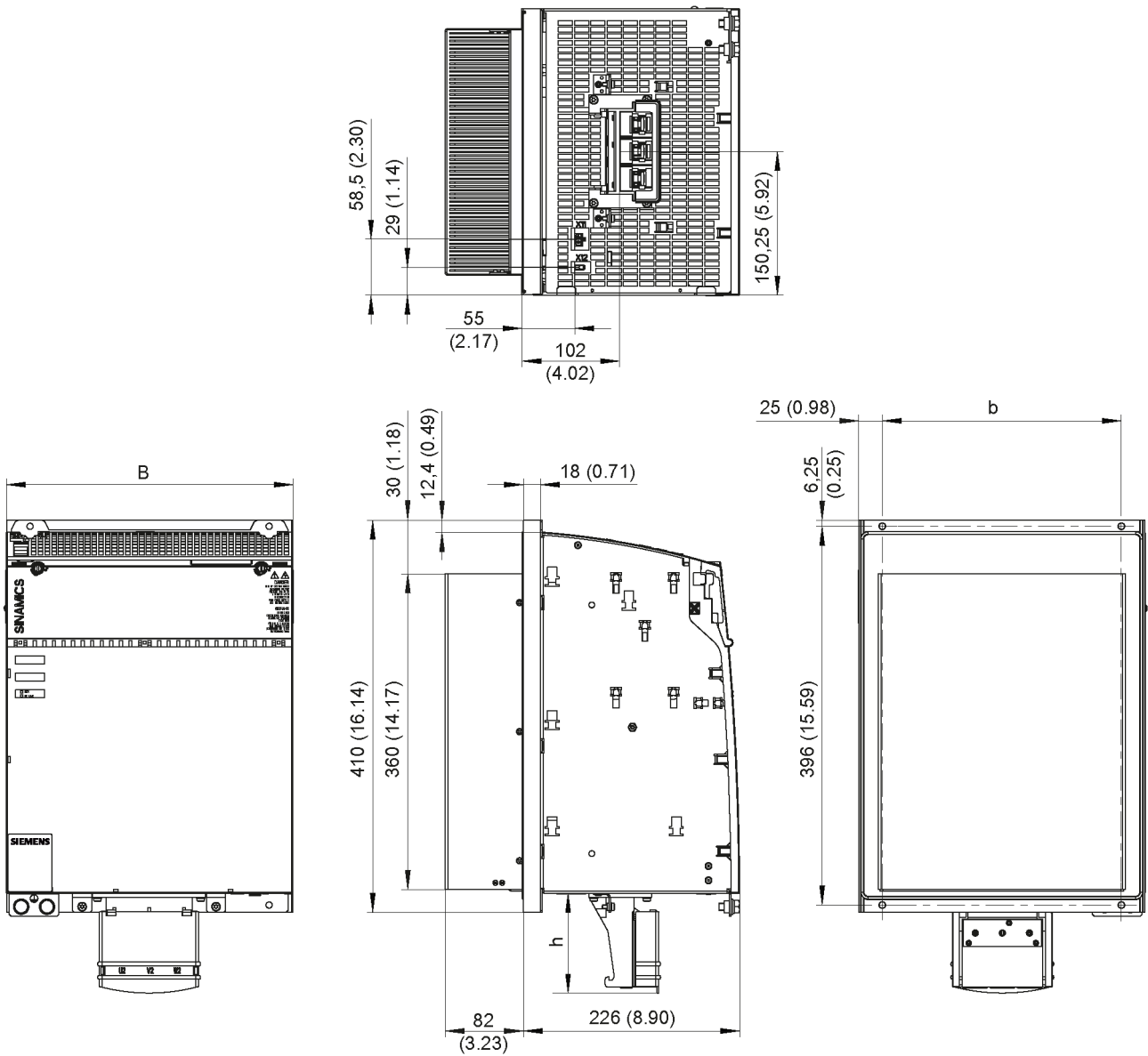

Figure 6-37 Dimension drawing of 132 A and 200 A Motor Modules Booksize, all dimensions in mm and (inches); example: 200 A Single Motor Module

Table 6- 25 Dimensions of 132 A and 200 A Motor Modules Booksize with external air cooling

Motor Module	Article No.	W [mm] (inch)	b [mm] (inch)	h [mm] (inch)
Single Motor Module 132 A	6SL3121-1TE31-3AA.	300 (11.81)	250 (9.84)	105 (4.13)
Single Motor Module 200 A	6SL3121-1TE32-0AA.			

6.3 Motor Module with external air cooling

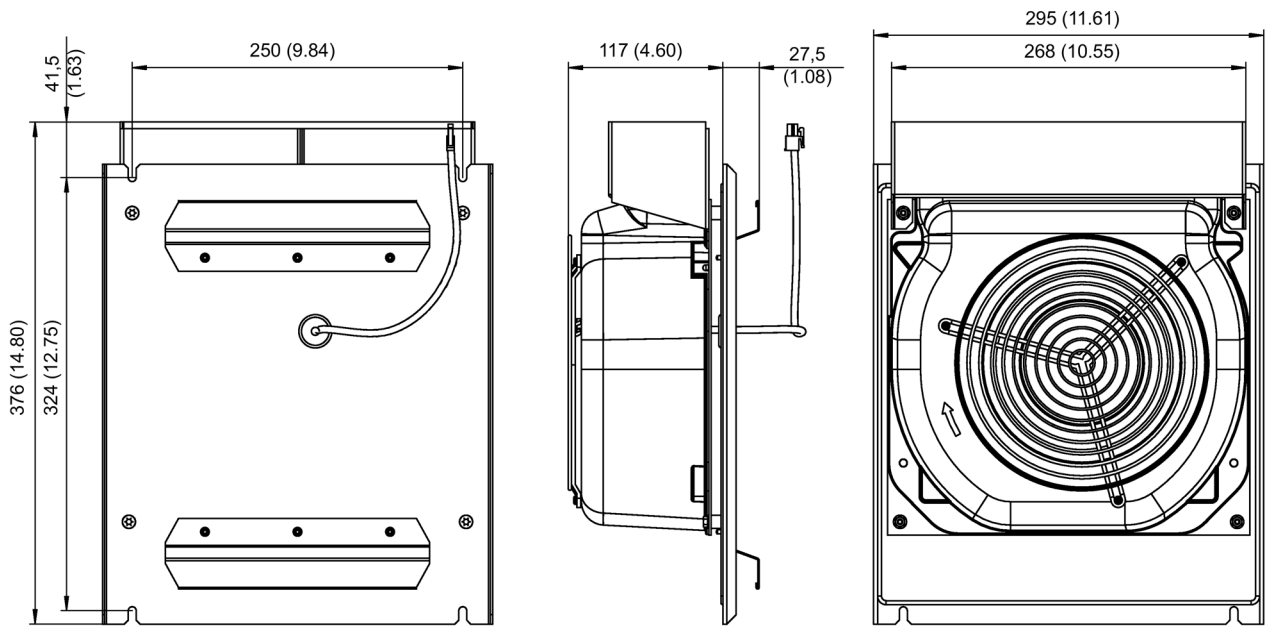
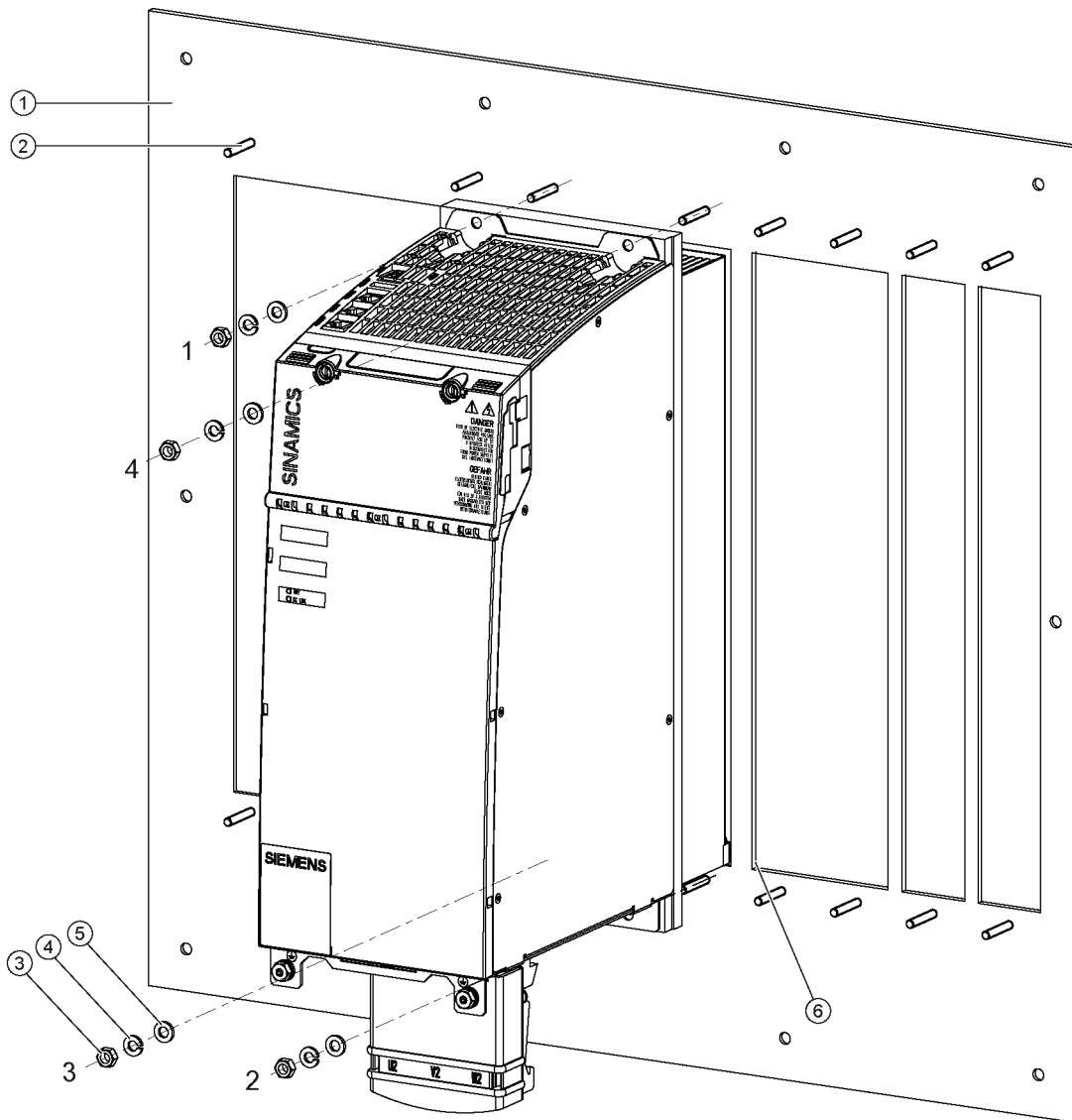

Figure 6-38 Dimension drawing of fan for 132 A and 200 A Motor Modules Booksize with external air cooling, all dimensions in mm and (inches)

Note

The fan for the Motor Modules 132 A and 200 A is included in the scope of supply.

6.3.6 Mounting



- ① Mounting plate with openings for mounting
- ② Threaded bolts M6
- ③ M6 nut
- ④ Spring washer
- ⑤ Washer
- ⑥ Fan assembly

Figure 6-39 Mounting a Motor Module with external air cooling

Tightening torques:

1. Firstly, tighten the nuts by hand.
Tightening torque: 0.5 Nm (4.4 lbf in)
2. Then tighten the nuts in the specified sequence 1 to 4.
Tightening torque: 6 Nm (53.1 lbf in)

Help with the mechanical control cabinet design is available from:

Siemens AG
Digital Factory, DF MC MF - WKC AS
TCCCC (Technical Competence Center Cabinets Chemnitz)
Postfach 1124
09070 Chemnitz
e-mail: cc.cabinetcooling.aud@siemens.com

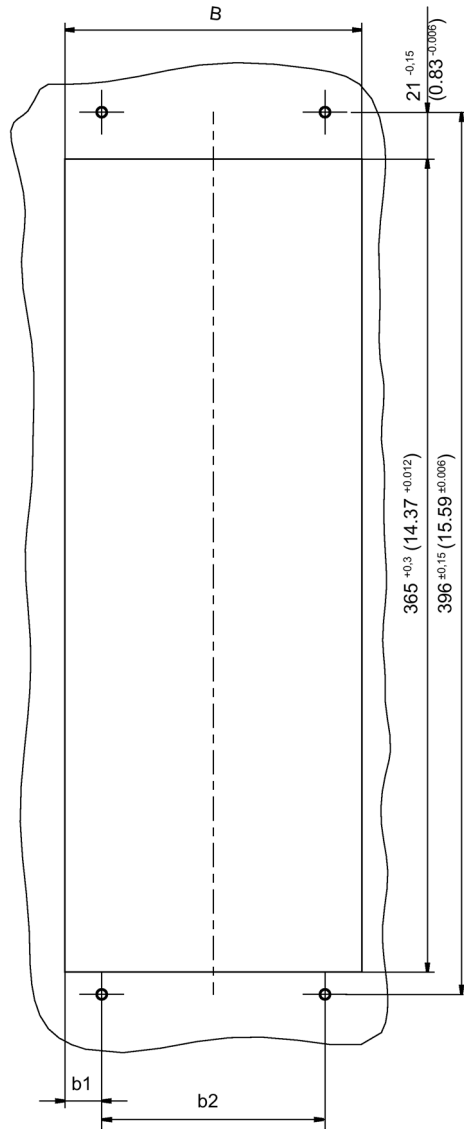
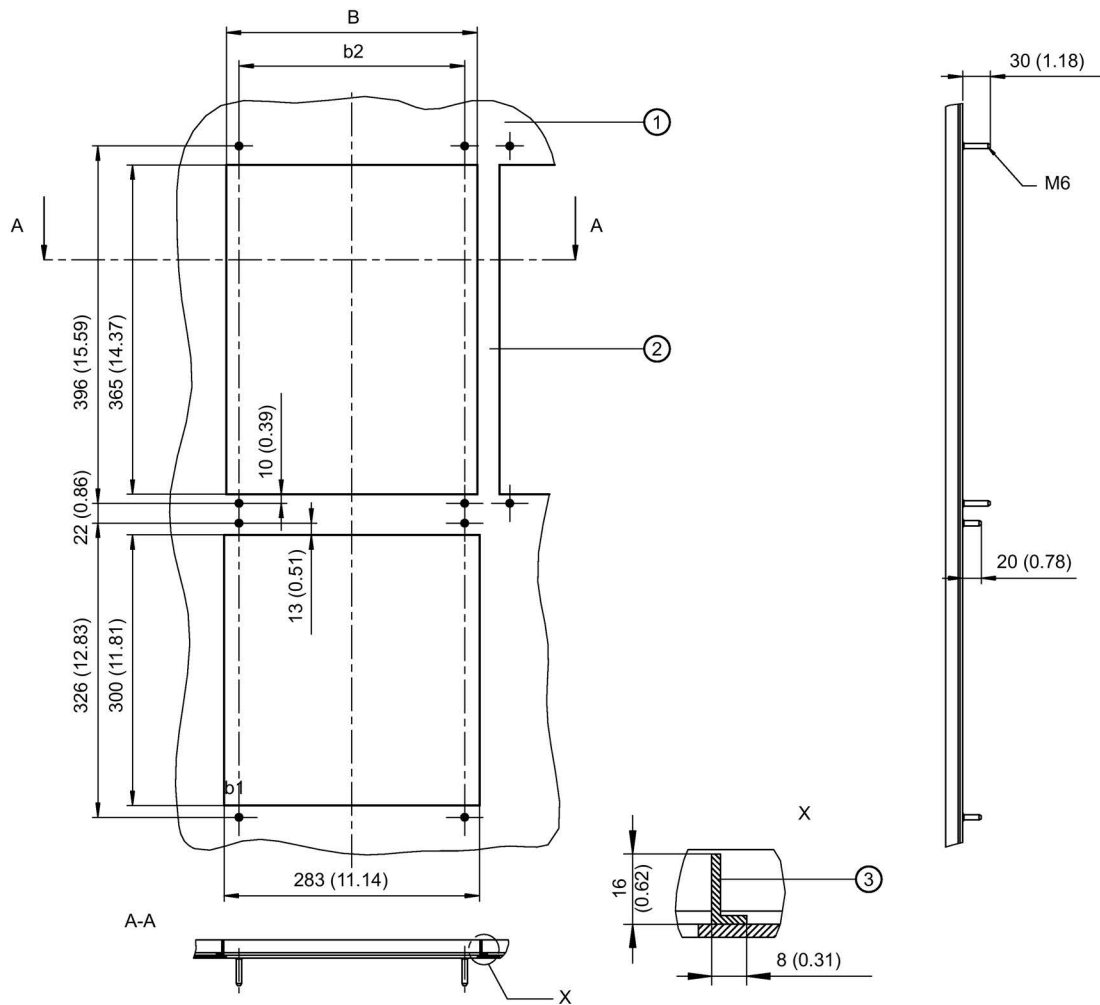

Figure 6-40 Opening to mount Motor Modules 50 mm to 200 mm with external air cooling, all data in mm and (inches)

6.3 Motor Module with external air cooling



- ① Insert plate or mounting plate
- ② Cross-piece
- ③ Reinforcing bracket

Figure 6-41 Openings to mount a Motor Module 300 mm with external air cooling, all data in mm and (inches)

Table 6- 26 Dimensions of openings to mount Motor Modules with external air cooling

Component width	W [mm] (inch)	b1 [mm] (inch)	b2 [mm] (inch)
50 mm	41.5 ^{+0.3} (1.63 ^{+0.012})	20.75 ^{+0.15} (0.82 ^{+0.006})	0
100 mm	89.5 ^{+0.3} (3.52 ^{+0.012})	19.75 ^{+0.15} (0.78 ^{+0.006})	50 ^{±0.15} (1.97 ^{±0.006})
150 mm	133 ^{+0.3} (5.24 ^{+0.012})	16.5 ^{+0.15} (0.65 ^{+0.006})	100 ^{±0.15} (3.94 ^{±0.006})
200 mm	173 ^{+0.3} (6.81 ^{+0.012})	11.5 ^{+0.15} (0.45 ^{+0.006})	150 ^{±0.15} (5.91 ^{±0.006})
300 mm	278 ^{+0.3} (10.94 ^{+0.012})	14.0 ^{±0.15} (0.55 ^{±0.006})	250 ^{+0.15} (9.84 ^{+0.006})

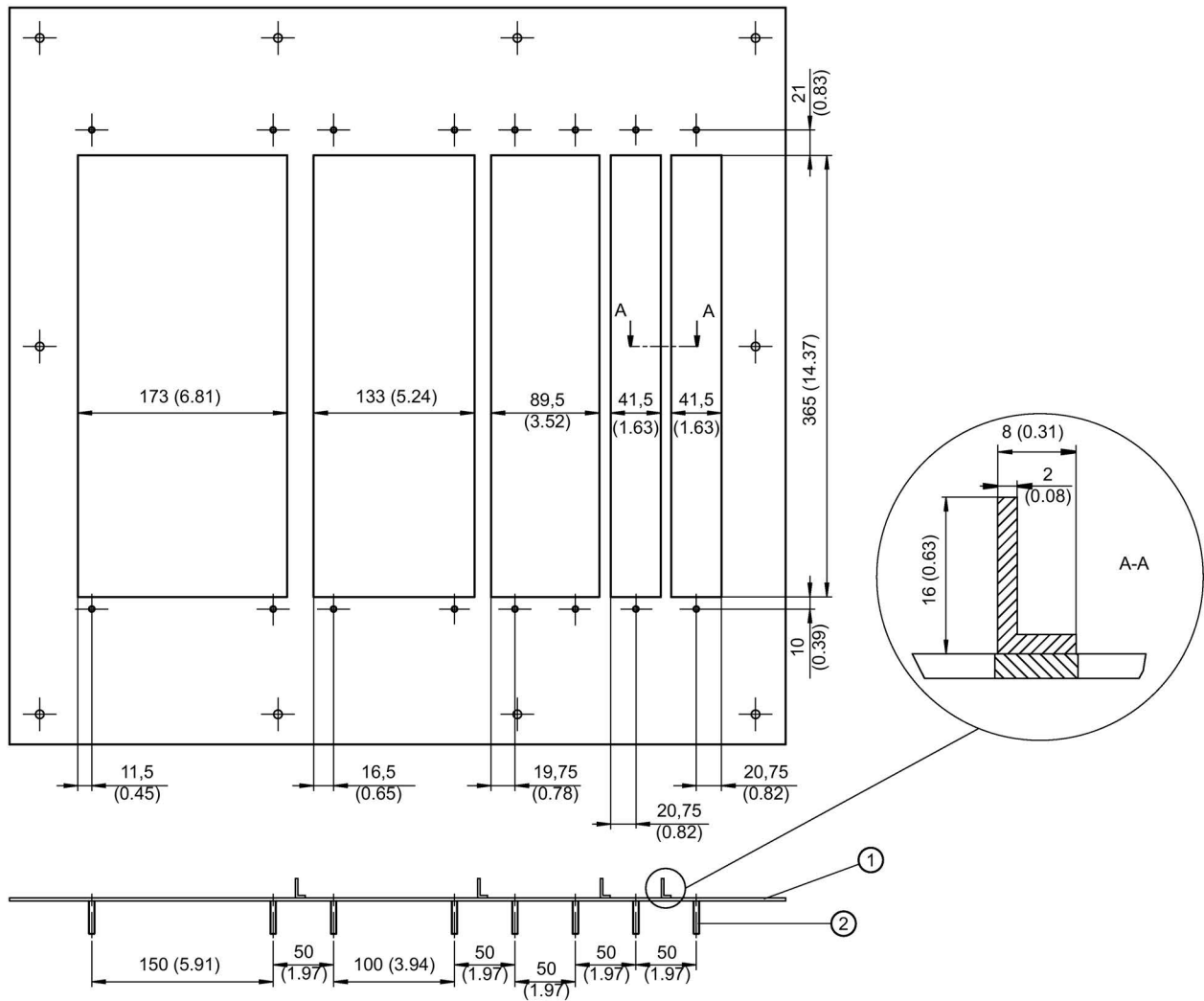

- ① Insert plate or mounting plate
- ② Threaded bolts M6 x 30

Figure 6-42 Example of a mounting plate for a drive line-up with external air cooling

When mounting it must be ensured that the component's seal is tight throughout. The cross-pieces must have the appropriate stability. If necessary, the cross-pieces of the openings must be reinforced.

In the example, the cross-pieces have been reinforced using brackets according to EN 755-9. You are free to select the way that the bracket is attached to the insert.

6.3 Motor Module with external air cooling

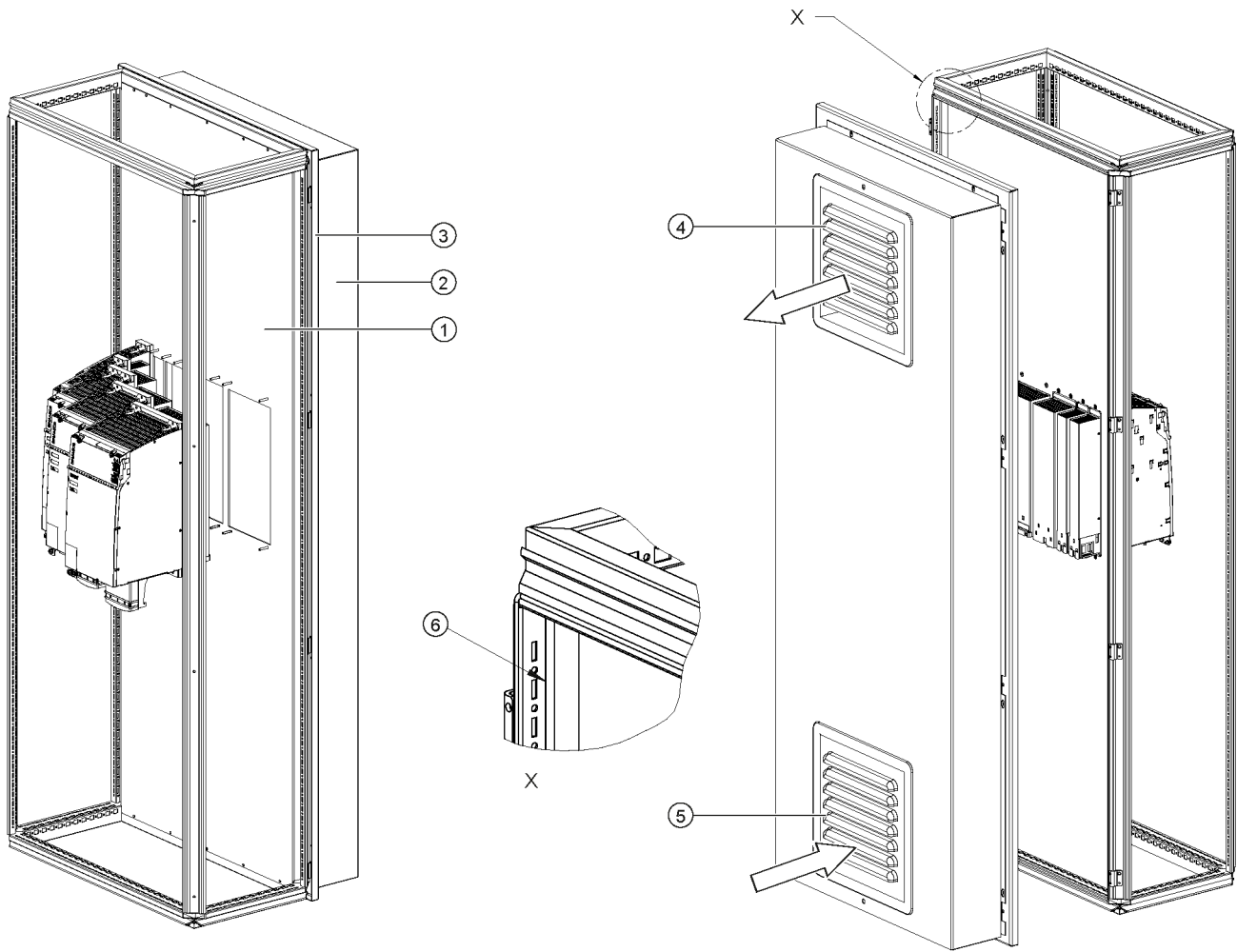

- ① Mounting plate
- ② Cover
- ③ Rear panel
- ④ Air discharge
- ⑤ Air inlet - filter with filter fan
- ⑥ To comply with degree of protection IP54, the surfaces ⑥ between the mounting plate and the cabinet strip must be sealed all round (e.g. Terostat-91 sealant from Teroson).

Figure 6-43 Example 1: mounting in the cabinet with mounting plate

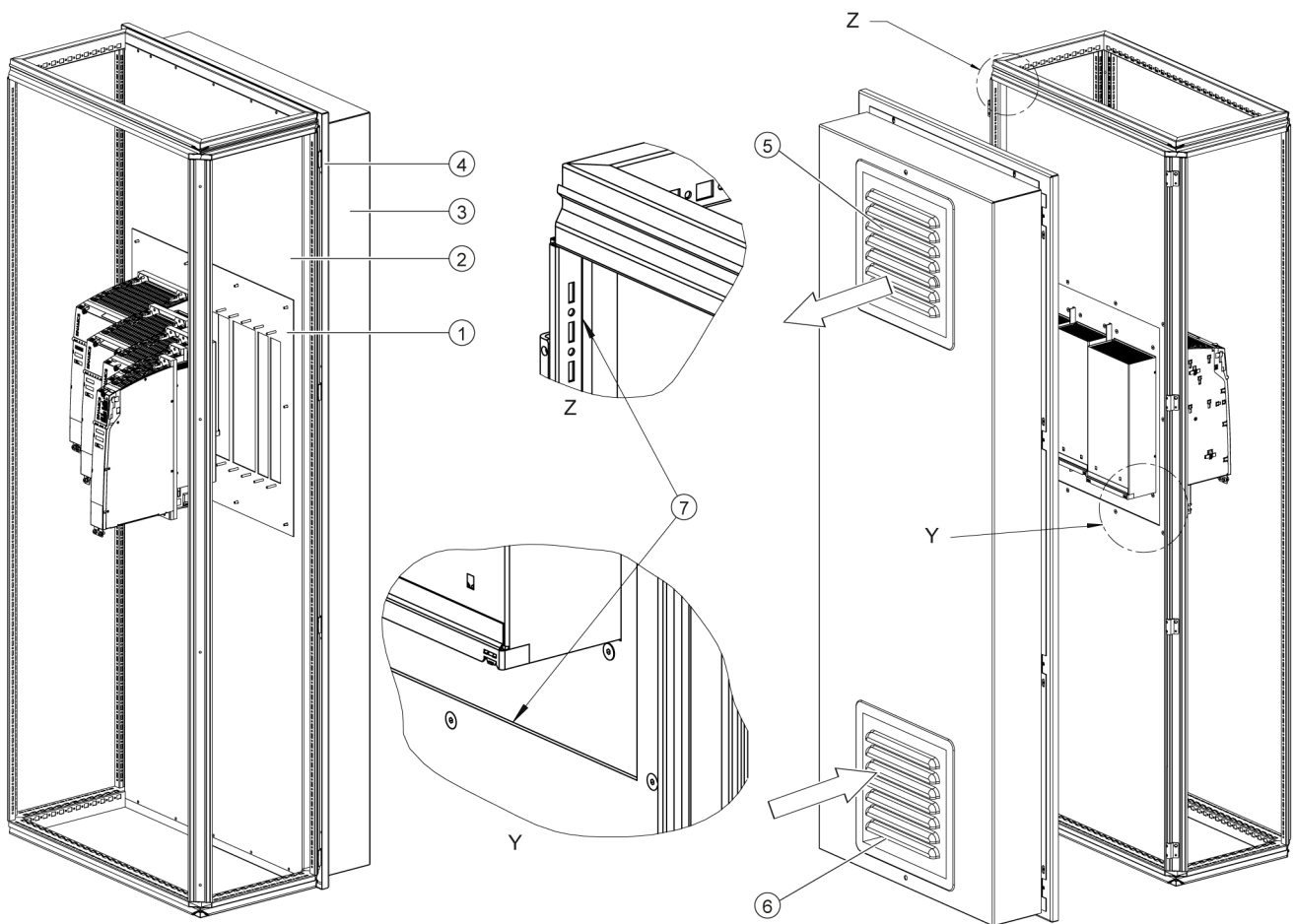

- ① Insert plate
- ② Mounting plate
- ③ Cover
- ④ Rear panel
- ⑤ Air discharge
- ⑥ Air inlet - filter with filter fan
- ⑦ To comply with degree of protection IP54, the surfaces ⑦ between the mounting plate and the cabinet strip and between the mounting plate and the insert plate must be sealed all round (e.g. Terostat-91 sealant from Teroson).

Figure 6-44 Example 2: mounting in the cabinet with mounting plate

It is recommended that you attach a cover and filter fan to the cabinet.

The filtered fan must be fitted in such a way that the cooling air required by the drive line-up is not restricted. The overall cooling air requirement is obtained from the sum of the individual components (see Chapter Technical data (Page 386)).

6.3 Motor Module with external air cooling

Note

If the cooling air requirement is not covered by the filtered fan, the components cannot output their specified power.

The filters with filter fan must be regularly checked for dirt and cleaned if necessary.

6.3.7 Technical data

6.3.7.1 Single Motor Modules

Table 6- 27 Technical data Single Motor Modules Booksize (3 to 30 A)

External air cooling	6SL3121-	1TE13-0AA.1)	1TE15-0AA.1)	1TE21-0AA.1)	1TE21-8AA.1)	1TE23-0AA.
Output current (at 600 V DC)						
Rated current (I _n)	A _{AC}	3	5	9	18	30
Base-load current (I _H)	A	2.6	4.3	7.7	15.3	25.5
Intermittent duty current (I _{s6})	A _{AC}	3.5	6	10	24	40
40%	A _{AC}	6	10	18	36	56
Peak current (I _{max})						
Output voltage	V _{AC}	0 ... 0.717 x DC-link voltage				
DC link current	A _{DC}	3.6	6	11	22	36
DC-link voltage	V _{DC}	510 ... 720				
DC link capacitance	μF	110	110	110	220	705
Overvoltage trip	V _{DC}	820 ± 2 %				
Undervoltage trip ²⁾	V _{DC}	380 ± 2 %				
Electronics power supply	V _{DC}	24 (20.4 ... 28.8)				
Electronics current consumption at 24 V DC	A _{DC}	0.85	0.85	0.85	0.85	0.8
Current carrying capacity						
DC link busbars	A _{DC}	100	100	100	100	100
Reinforced DC link busbars	A _{DC}	150	150	150	150	150
24 V DC busbars	A _{DC}	20	20	20	20	20
Unit rating³⁾						
Based on I _n (600 VDC; 4 kHz)	kW	1.6	2.7	4.8	9.7	16
Based on I _H	kW	1.4	2.3	4.1	8.2	13.7
Total power loss (including electronics losses, see Power loss tables (Page 734))	W	50.4	73.4	100.4	185.4	309.2
Max. pulse frequency						
without derating	kHz	4				
with derating	kHz	16				
Output frequency	Hz	0 ... 550				

External air cooling	6SL3121-	1TE13-0AA. ¹⁾	1TE15-0AA. ¹⁾	1TE21-0AA. ¹⁾	1TE21-8AA. ¹⁾	1TE23-0AA.
Sound pressure level	dB(A)	< 60	< 60	< 60	< 60	< 60
Cooling air requirement	m ³ /h	29.6	29.6	29.6	29.6	56
Max. permissible heat sink temperature	°C	70	70	73	82	85
Ventilation clearances above/below	mm	≥ 80				
Weight	kg	5.7	5.7	5.7	5.7	8.4

1) Applies only to Article numbers with "." = 0 ... 3

2) Default for 400 V line systems; undervoltage trip threshold can be reduced by up to 80 V and is adjusted to the parameterized rated voltage

3) Rated power of a typical standard induction motor at 400 V 3 AC.

Table 6- 28 Technical data Single Motor Modules Booksize (45 to 200 A)

External air cooling	6SL3121-	1TE24-5AA.	1TE26-0AA.	1TE28-5AA.	1TE31-3AA.	1TE32-0AA.
Output current (at 600 V DC)						
Rated current (I _n)	A _{AC}	45	60	85	132	200
Base-load current (I _H)	A	38	51	68	105	141
Intermittent duty current (I _{S6})	A _{AC}	60	80	110	150	230
40%	A _{AC}	85	113	141	210	282
Peak current (I _{max})						
Output voltage	V _{AC}	0 ... 0.717 x DC-link voltage				
DC link current	A _{DC}	54	72	102	158	200
DC-link voltage	V _{DC}	510 ... 720				
DC link capacitance	μF	1175	1410	1880	2820	3995
Overvoltage trip	V _{DC}	820 ± 2 %				
Undervoltage trip ¹⁾	V _{DC}	380 ± 2 %				
Electronics power supply	V _{DC}	24 (20.4 ... 28.8)				
Electronics current consumption at 24 V DC	A _{DC}	1.05	1.05	1.5	0.85	0.85
Current carrying capacity						
DC link busbars	A _{DC}	200	200	200	200	200
24 V DC busbars	A _{DC}	20	20	20	20	20
Unit rating²⁾						
Based on I _n (600 VDC; 4 kHz)	kW	24	32	46	71	107
Based on I _H	kW	21	28	37	57	76
Total power loss (including electronics losses, see Power loss tables (Page 734))	W	455.2	615.2	786	1270.4	2070.4
Max. pulse frequency without derating	kHz	4				
with derating	kHz	16				
Output frequency	Hz	0 ... 550				
Sound pressure level	dB(A)	< 65	< 65	< 60	< 73	< 73
Cooling air requirement	m ³ /h	112	112	160	520	520

6.3 Motor Module with external air cooling

External air cooling	6SL3121-	1TE24-5AA.	1TE26-0AA.	1TE28-5AA.	1TE31-3AA.	1TE32-0AA.
Max. permissible heat sink temperature	°C	85	90	88	73	80 (70 % derating)
Ventilation clearances above/below	mm	≥ 80				
Weight	kg	12.7	13.0	19.2	27.3	27.9

- 1) Default for 400 V line systems; undervoltage trip threshold can be reduced by up to 80 V (exception: 132 A and 200 A Motor Modules) and is adjusted to the parameterized rated voltage.
- 2) Rated power of a typical standard induction motor at 400 V 3 AC.

6.3.7.2 Double Motor Modules

Table 6- 29 Technical data, Double Motor Modules Booksize (2 x 3 to 2 x 18 A)

External air cooling	6SL3121-	2TE13-0AA.¹⁾	2TE15-0AA.¹⁾	2TE21-0AA.¹⁾	2TE21-8AA.
Output current (at 600 V DC)					
Rated current (I _n)	A _{AC}	2 x 3	2 x 5	2 x 9	2 x 18
Base-load current (I _H)	A	2 x 2.6	2 x 4.3	2 x 7.7	2 x 15.3
Intermittent duty current (I _{s6}) 40%	A _{AC}	2 x 3.5	2 x 6	2 x 10	2 x 24
Peak current (I _{max})	A _{AC}	2 x 6	2 x 10	2 x 18	2 x 36
Output voltage	V _{AC}	0 ... 480			
DC link current	A _{DC}	7.2	12	22	43
DC-link voltage	V _{DC}	510 ... 720			
DC link capacitance	µF	110	220	220	705
Overvoltage trip	V _{DC}	820 ± 2 %			
Undervoltage trip ²⁾	V _{DC}	380 ± 2 %			
Electronics power supply	V _{DC}	24 (20.4 ... 28.8)			
Electronics current consumption at 24 V DC	A _{DC}	1.15	1.15	1.15	1.3
Current carrying capacity					
DC link busbars	A _{DC}	100	100	100	100
Reinforced DC link busbars	A _{DC}	150	150	150	150
24 V DC busbars	A	20	20	20	20
Unit rating³⁾					
Based on I _n (600 VDC; 4 kHz)	kW	2 x 1.6	2 x 2.7	2 x 4.8	2 x 9.7
Based on I _H	kW	2 x 1.4	2 x 2.3	2 x 4.4	2 x 8.2
Total power loss (including electronics losses, see Power loss tables (Page 734))	W	97.6	132.6	187.6	351.2
Max. pulse frequency without derating with derating	kHz kHz	4 16			
Output frequency	Hz	0 ... 550			
Sound pressure level	dB(A)	< 60	< 60	< 60	< 60
Cooling air requirement	m ³ /h	29.6	29.6	29.6	56
Max. permissible heat sink temperature	°C	80	85	89	90

External air cooling	6SL3121-	2TE13-0AA.1)	2TE15-0AA.1)	2TE21-0AA.1)	2TE21-8AA.
Ventilation clearances above/below	mm	≥ 80			
Weight	kg	5.8	5.8	5.7	8.6

- 1) Applies only to Article numbers with "." = 0 ... 3
- 2) Default for 400 V line systems; undervoltage trip threshold can be reduced by up to 80 V and is adjusted to the parameterized rated voltage
- 3) Rated power of a typical standard induction motor at 400 V 3 AC.

6.3.7.3 Characteristics

Rated duty cycles Motor Modules Booksize

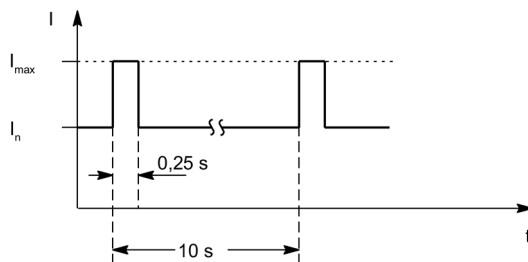

Figure 6-45 Duty cycle with initial load (for servo drives)

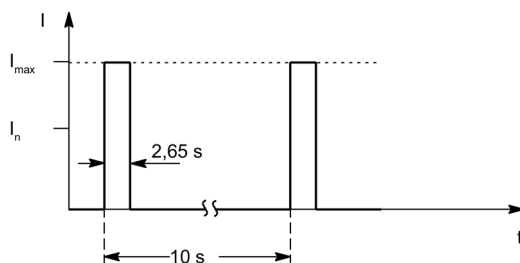

Figure 6-46 Duty cycle without initial load (for servo drives)

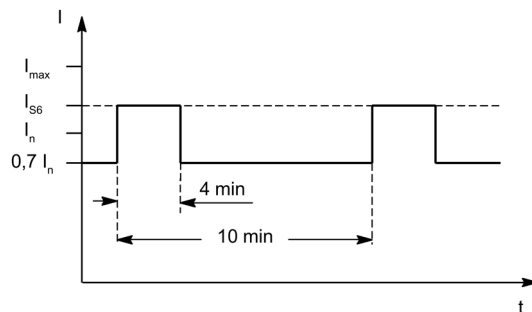

Figure 6-47 S6 duty cycle with initial load with a duty cycle duration of 600 s (for servo drives)

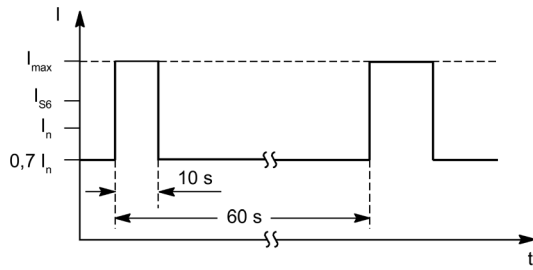

Figure 6-48 S6 duty cycle with initial load with a duty cycle duration of 60 s (for servo drives)

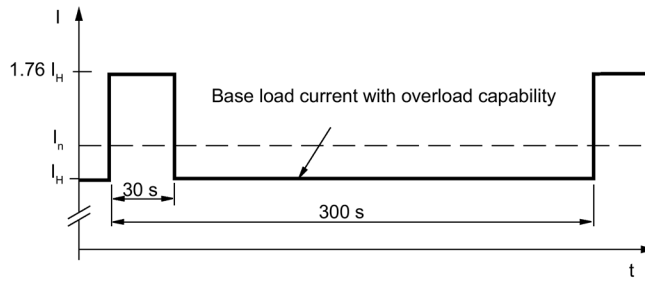

Figure 6-49 Duty cycle with 30 s overload for a duty cycle duration of 300 s

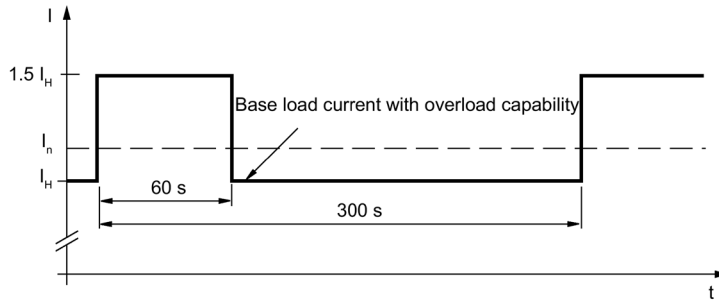

Figure 6-50 Duty cycle with 60 s overload for a duty cycle duration of 300 s

Derating characteristics for Motor Modules Booksize

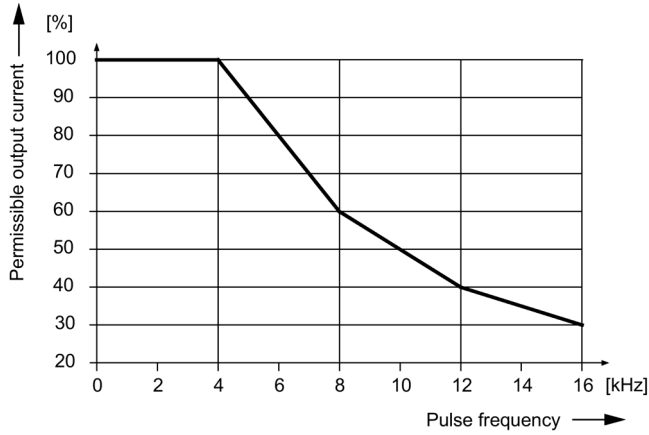

Figure 6-51 Output current as a function of the pulse frequency

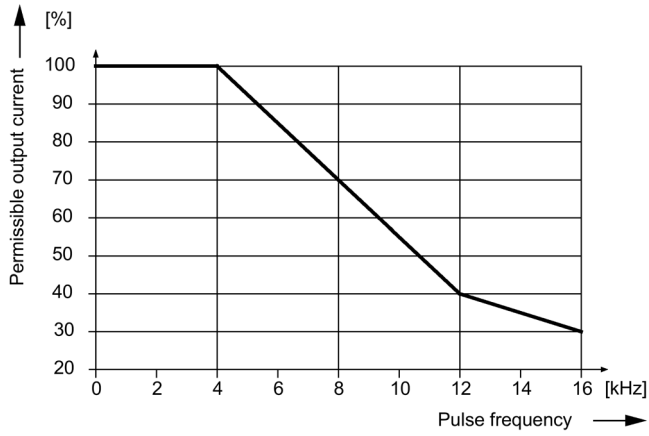

Figure 6-52 Output current as a function of the pulse frequency for 200 A Motor Modules (applies from Article number 6SL312.-1TE32-0AA4)

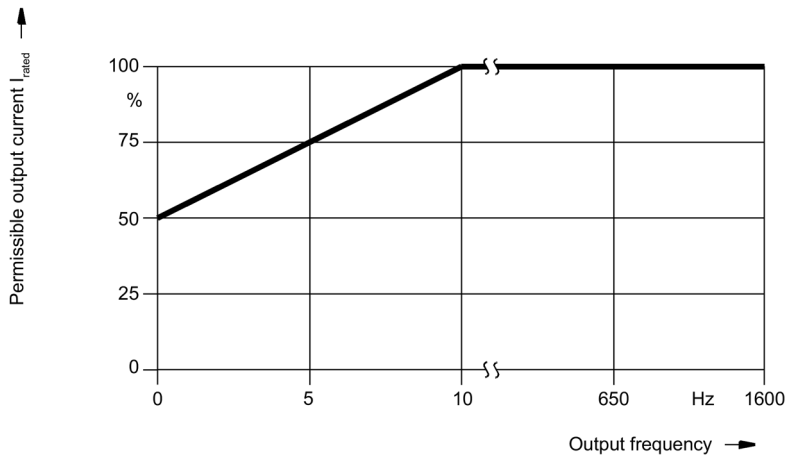

Figure 6-53 Output current at low frequencies

6.3 Motor Module with external air cooling

Dimensioning notes:

- A current derating is only applicable for output frequencies < 10 Hz.
- Current derating should be taken into account if the percentage time of operation at frequencies < 10 Hz is more than 2 % of the daily total operating time.
- Also during load cycles, the current specified here must not be exceeded.
- When quickly passing through frequencies 0 to 10 Hz, derating does not have to be taken into account (e.g. for positioning applications).

Note

Information about derating the output current as a function of the ambient temperature and installation altitude is provided in Chapter "System data (Page 42)".

6.3.8 Technical data for Motor Modules Booksize with 300% overload

6.3.8.1 Single Motor Modules (300% overload)

Table 6- 30 Technical data Single Motor Modules Booksize (3 to 18 A) with 3-fold overload

External air cooling	6SL3121–	1TE13-0AA4	1TE15-0AA4	1TE21-0AA4	1TE21-8AA4
Output current (at 600 V DC)					
Rated current (I _n)	A _{AC}	3	5	9	18
Base-load current (I _H)	A	2.6	4.3	7.7	15.3
Intermittent duty current (I _{SB}) 40%	A _{AC}	3.5	6	10	24
Peak current (I _{max})	A _{AC}	9	15	27	54
Output voltage	V _{AC}	0 ... 0.717 x DC-link voltage			
DC-link current	A _{DC}	3.6	6	11	22
DC-link voltage	V _{DC}	510 ... 720			
DC link capacitance	µF	110	110	110	220
Overvoltage trip	V _{DC}	820 ± 2 %			
Undervoltage trip ¹⁾	V _{DC}	380 ± 2 %			
Electronics power supply	V _{DC}	24 (20.4 ... 28.8)			
Electronics current consumption at 24 V DC	A _{DC}	0.85			
Current carrying capacity					
DC link busbars	A _{DC}	100			
Reinforced DC link busbars	A _{DC}	150			
24 V DC busbars	A _{DC}	20			
Unit rating²⁾					
Based on I _n (600 VDC; 4 kHz)	kW	1.6	2.7	4.8	9.7
Based on I _H	kW	1.4	2.3	4.1	8.2
Total power loss (including electronics losses, see Power loss tables (Page 734))	W	50.4	73.4	100.4	185.4

External air cooling	6SL3121-	1TE13-0AA4	1TE15-0AA4	1TE21-0AA4	1TE21-8AA4
Max. pulse frequency without derating	kHz	4			
	with derating	16			
Output frequency	Hz	0 ... 550			
Sound pressure level	dB(A)	< 60			
Cooling air requirement	m ³ /h	29.6			
Max. permissible heat sink temperature	°C	70	70	70	90
Ventilation clearances above/below	mm	≥ 80			
Weight	kg	5.7	5.7	5.7	5.7

- 1) Default for 400 V line systems; undervoltage trip threshold can be reduced by up to 80 V and is adjusted to the parameterized rated voltage
- 2) Rated power of a typical standard induction motor at 400 V 3 AC

Note

Operation of 18 A Single Motor Modules with 3-fold overload connected to a 16 kW Line Module

The maximum power of a 16 kW Line Module is not sufficient for operating 18 A Single Motor Modules at their peak current.

- Take the motor power into consideration if you wish to operate an 18 A Single Motor Module on a 16 kW Line Module. Depending on the operating state, the power consumption of these Single Motor Modules can be > 35 kW, and it may be necessary to install a Line Module with a higher power rating for applications such as these.

6.3.8.2 Double Motor Modules (300% overload)

Table 6- 31 Technical data Double Motor Modules Booksize (2 x 3 to 2 x 9 A) with 3-fold overload

External air cooling	6SL3121-	2TE13-0AA4	2TE15-0AA4	2TE21-0AA4
Output current (at 600 V DC)				
Rated current (I_n)	A_{AC}	2 x 3	2 x 5	2 x 9
Base-load current (I_H)	A	2 x 2.6	2 x 4.3	2 x 7.7
Intermittent duty current (I_{S6}) 40%	A_{AC}	2 x 3.5	2 x 6	2 x 10
Peak current (I_{max})	A_{AC}	2 x 9	2 x 15	2 x 27
Output voltage	V_{AC}	0 ... 480		
DC link current	A_{DC}	7.2	12	22
DC-link voltage	V_{DC}	510 ... 720		
DC link capacitance	μF	110	220	220
Overvoltage trip	V_{DC}	820 ± 2 %		
Undervoltage trip ¹⁾	V_{DC}	380 ± 2 %		
Electronics power supply	V_{DC}	24 (20.4 ... 28.8)		
Electronics current consumption at 24 V DC	A_{DC}	1.15		

6.3 Motor Module with external air cooling

External air cooling	6SL3121-	2TE13-0AA4	2TE15-0AA4	2TE21-0AA4
Current carrying capacity				
DC link busbars	A _{DC}	100		
Reinforced DC link busbars	A _{DC}	150		
24 V DC busbars	A	20		
Unit rating²⁾				
Based on I _n (600 VDC; 4 kHz)	kW	2 x 1.6	2 x 2.7	2 x 4.8
Based on I _H	kW	2 x 1.4	2 x 2.3	2 x 4.4
Total power loss (including electronics losses, see Power loss tables (Page 734))	W	97.6	132.6	187.6
Max. pulse frequency				
without derating	kHz	4		
with derating	kHz	16		
Output frequency	Hz	0 ... 550		
Sound pressure level	dB(A)	< 60		
Cooling air requirement	m ³ /h	29.6		
Max. permissible heat sink temperature	°C	78	78	78
Ventilation clearances above/below	mm	≥ 80		
Weight	kg	5.8	5.8	5.7

- 1) Default for 400 V line systems; undervoltage trip threshold can be reduced by up to 80 V and is adjusted to the parameterized rated voltage
- 2) Rated power of a typical standard induction motor at 400 V 3 AC

Note

Disturbance of the 2 x 9 A Double Motor Module with 3-fold overload on a 16 kW Line Module

The maximum output of a 16 kW Line Module is not sufficient for the operation of a 2 x 9 A Double Motor Module with 3-fold overload.

- Do NOT operate a 2 x 9 A Double Motor Module with a 16 kW Line Module with 3-fold overload (i.e. only operate a 2 x 9 A Double Motor Module with a 16 kW Line Module, if the maximum current is limited to 2 x I_{rated}).
- Use at least a 36 kW Active Line Module or Smart Line Module for operation with 3-fold overload.

6.3.8.3 Characteristics for Motor Modules Booksize with 300% overload

Rated duty cycles Motor Modules Booksize with 300% overload

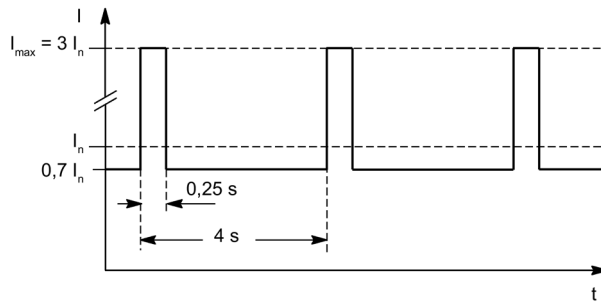

Figure 6-54 Peak current duty cycle with initial load (300% overload)

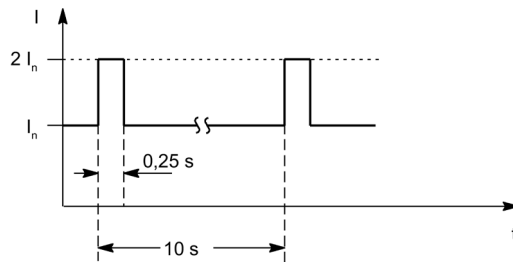

Figure 6-55 Duty cycle with initial load

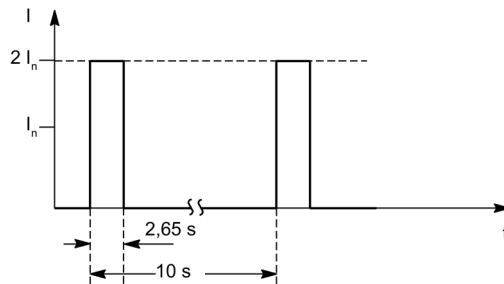

Figure 6-56 Duty cycle without initial load

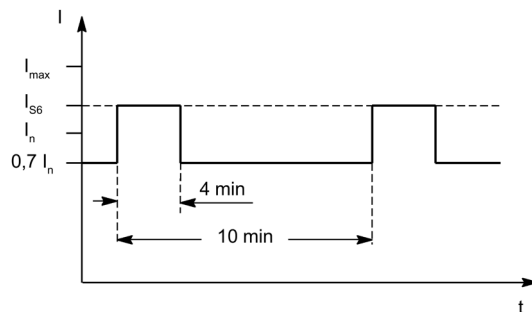

Figure 6-57 S6 duty cycle with initial load for a duty cycle duration of 600 s

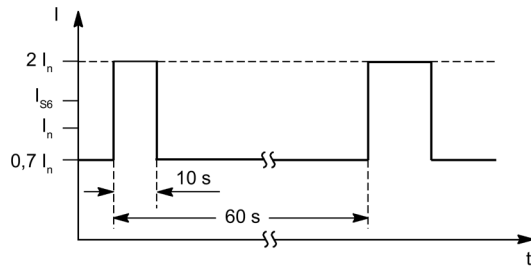

Figure 6-58 S6 duty cycle with initial load for a duty cycle duration of 60 s

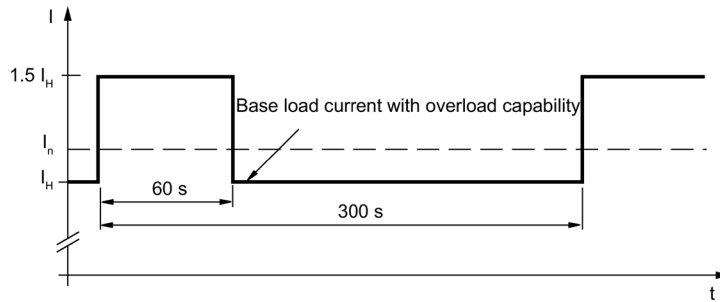

Figure 6-59 Duty cycle with 60 s overload for a duty cycle duration of 300 s

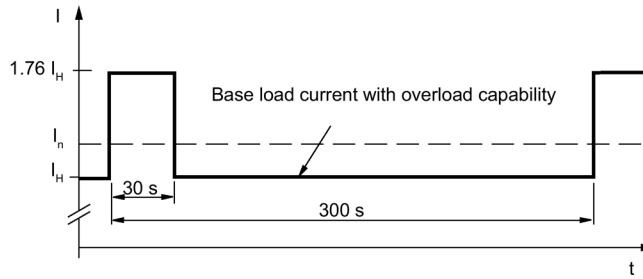

Figure 6-60 Duty cycle with 30 s overload for a duty cycle duration of 300 s

Derating characteristics for Motor Modules Booksize with 300% overload

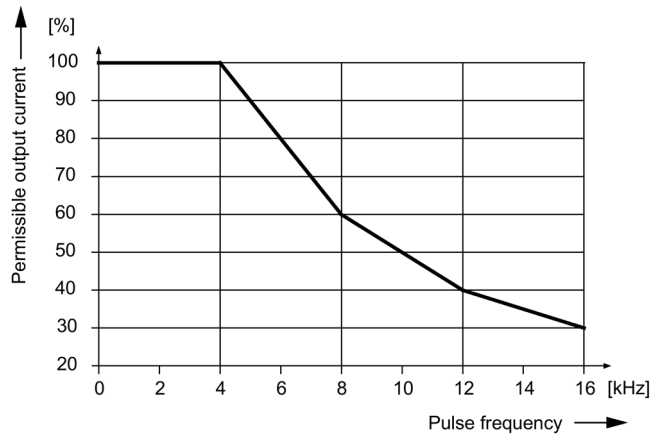

Figure 6-61 Output current as a function of the pulse frequency

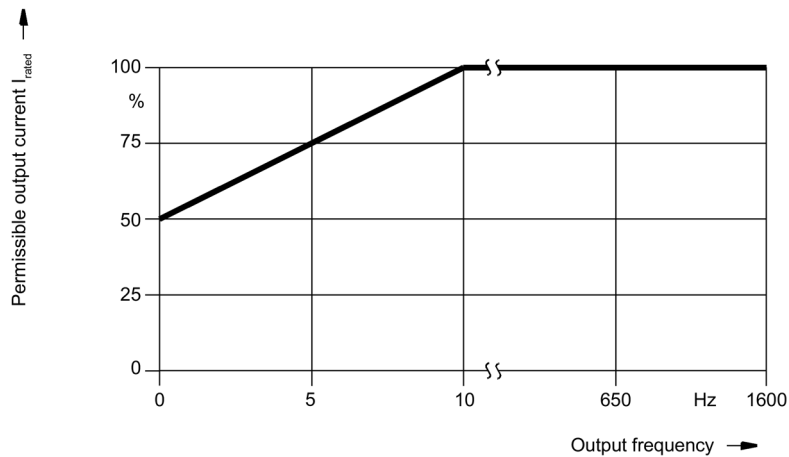

Figure 6-62 Output current at low frequencies

Dimensioning notes:

- A current derating is only applicable for output frequencies < 10 Hz.
- Current derating should be taken into account if the percentage time of operation at frequencies < 10 Hz is more than 2 % of the daily total operating time.
- Also during load cycles, the current specified here must not be exceeded.
- When quickly passing through frequencies 0 to 10 Hz, derating does not have to be taken into account (e.g. for positioning applications).

Note

Information about derating the output current as a function of the ambient temperature and installation altitude is provided in Chapter "System data (Page 42)".

6.4 Motor Modules with cold plate

6.4.1 Description

A Motor Module is a power unit (inverter) that provides the power for the connected motors. Power is supplied by the DC link of the drive unit. A Motor Module must be connected to a Control Unit via DRIVE-CLiQ. The open-loop and closed-loop control functions for the Motor Module are stored in the Control Unit.

One motor can be connected to Single Motor Modules and 2 motors can be connected to Double Motor Modules.

6.4.2 Interface description

6.4.2.1 Overview

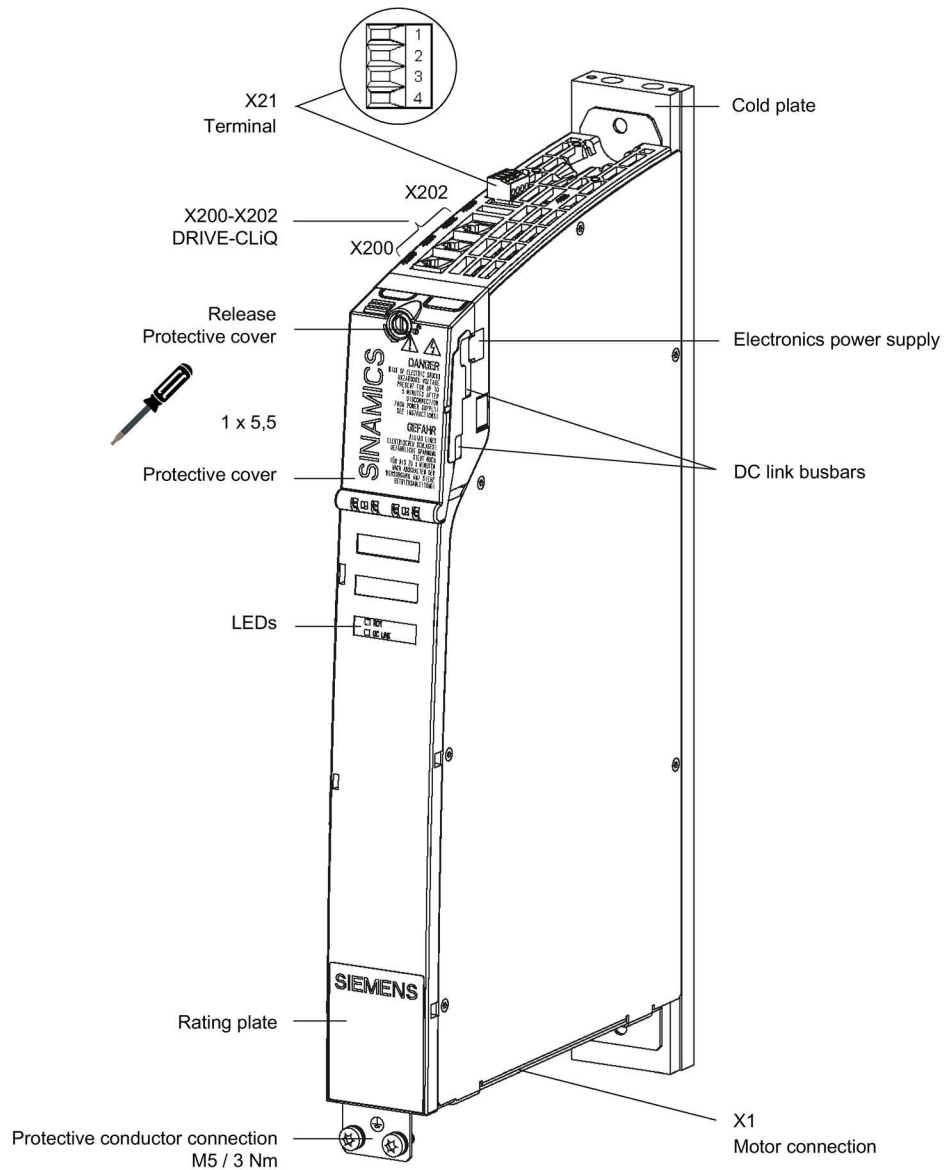

Figure 6-63 Interface overview, Single Motor Module Booksize with cold plate (example: 5 A)

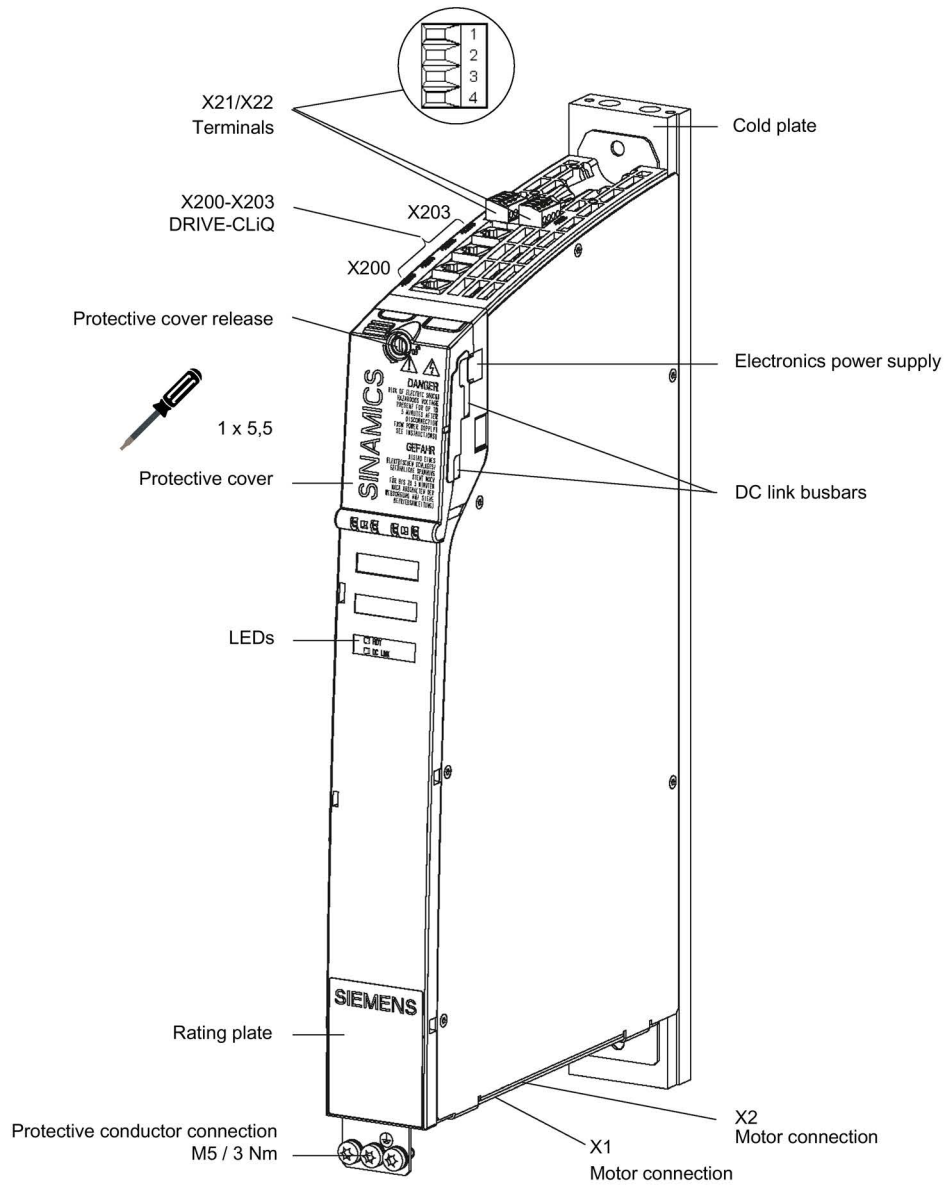

Figure 6-64 Interface overview, Double Motor Module Booksize with cold plate (example: 2 x 5 A)

6.4.2.2 Motor and brake connection

Table 6- 32 X1/X2 motor and brake connections for Single Motor Modules 3 A to 30 A and Double Motor Modules 2 x 3 A to 2 x 18 A

	Terminal	Technical data
	U (U2)	Motor connection
	V (V2)	
	W (W2)	
	+ (BR+)	Brake connection: Supply voltage: 24 V DC ±10% Max. load current: 2 A Minimum load current: 0.1 A
- (BR-)		
	Protective conductor connection	Single Motor Modules 3 ... 30 A: Threaded hole M5 / 3 Nm (26.6 lbf in) ¹⁾
		Double Motor Modules 2 x 3 ... 2 x 18 A: Threaded hole M5 / 3 Nm (26.6 lbf in) ¹⁾
¹⁾ For ring cable lugs without insulation (Page 710)		

Table 6- 33 X1 motor connection and X11 brake connection for Single Motor Modules 45 A to 200 A

	Terminal	Technical data
	U2	45 ... 60 A: Threaded bolts M6 / 6 Nm (53.1 lbf in) ¹⁾ 85 A: Threaded bolts M8 / 13 Nm (115 lbf in) ¹⁾ 132 ... 200 A: Threaded bolts M8 / 13 Nm (115 lbf in) ¹⁾
	V2	
	W2	
	Protective conductor connection	45 ... 60 A: Threaded bolts for motor cables: M6 / 6 Nm (53.1 lbf in) ¹⁾ Threaded hole for protective conductor: M6 / 6 Nm (53.1 lbf in) ¹⁾
		85 A: Threaded bolts for motor cables: M8 / 13 Nm (115 lbf in) ¹⁾ Threaded hole for protective conductor: M6 / 6 Nm (53.1 lbf in) ¹⁾ 132 ... 200 A: Threaded bolts for motor cables: M8 / 13 Nm (115 lbf in) ¹⁾ Threaded hole for protective conductor: M8 / 13 Nm (115 lbf in) ¹⁾
	+ (BR+)	X11 brake connector²⁾: Supply voltage: 24 V DC ±10 % Max. load current: 2 A Minimum load current: 0.1 A Type: Spring-loaded terminal 2 (Page 708) The brake connector is part of the prefabricated cable.
	- (BR-)	

¹⁾ For ring cable lugs without insulation (Page 710)

²⁾ The circuit for protecting the brake against overvoltage is integrated in the Motor Module and does not need to be installed externally.

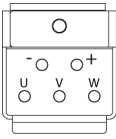
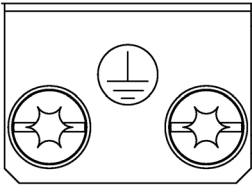
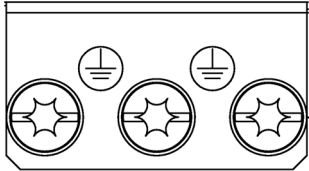
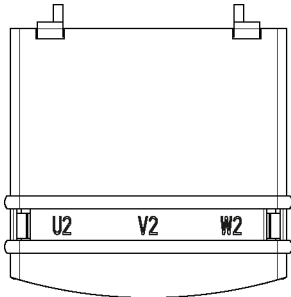
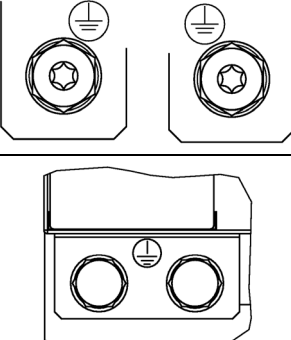
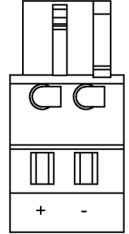
Motor holding brake connection

To ensure reliable opening of the motor holding brake, it requires a 24 V ± 10% voltage supply at the motor connection. It must be taken into account that voltage dips can occur along the supply cable.

- Use a Control Supply Module or a regulated DC power supply, whose setpoint is set to 26 V.
- Use supply cables with a minimum cross-section of 1.5 mm² (AWG 16) and a maximum length of 100 m.

Note

Protective circuit against overvoltage

The Motor Modules have an integrated overvoltage protection circuit for the motor holding brake. External protective circuits are not required.

 **WARNING**

High contact voltage on brake cables

For motor cables with integrated brake cable, when the motor is operated, the motor can charge the brake cable up to hazardous voltage levels. Coming into contact with the conductors or the shield of the brake cable can result in death or serious injury.

- Use motor cables with separate, shielded brake cables and connect the shield of the brake cable at both ends.

NOTICE

Premature wear of the motor holding brake when operated outside its permissible voltage range

Operating the motor holding brake outside its permissible voltage range at the motor connection will damage the brake.

- Ensure that the motor holding brake is only operated within its permissible voltage range.

NOTICE

Faulty brake function due to inadmissible wear

Inadmissible wear means that the braking function can no longer be guaranteed.

- Comply with the predefined Emergency Stop characteristics.
- Avoid repeated brief acceleration of the motor against a holding brake that is still closed. Consider the operating times of the brakes and the relays in the drive control and enable.

Note

The total length of the power cables (motor feeder cables and DC link cables) must not exceed the values listed in Chapter "Combination options, Line Modules with line reactors and line filters (Page 120)".

Note

The motor brake must be connected via connector X11. It is not permitted to directly connect the cable BR- to the electronics ground M.

6.4.2.3 X21/X22 EP terminals/temperature sensor

Table 6- 34 X21/X22 EP terminals / temperature sensor

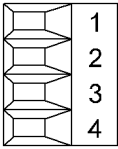
	Terminal	Function	Technical data
	1	+ Temp	Temperature sensors: KTY84-1C130 / PT1000 / PTC / bimetallic switch with NC contact
	2	- Temp	
	3	EP +24 V (pulse enable)	Supply voltage: 24 V DC (20.4 ... 28.8 V) Current consumption, typical: 4 mA at 24 V Isolated input The pulse inhibit function is only available when the "Safety Integrated Basic Functions via onboard terminals" software is enabled.
	4	EP M1 (enable pulses)	
Type: Screw terminal 1 (Page 708)			

EP terminals

Parameters p9651 and p9851 are used to set the filter times for debouncing terminals X21.3 and X21.4, as well as X22.3 and X22.4 (see SINAMICS S120/S150 List Manual). Additional parameter settings are also required in order to prevent discrepancy errors when performing bit pattern tests (light/dark tests). For comprehensive information, see the SINAMICS S120 Safety Integrated Function Manual, Section "Controlling the safety functions".

Note

Function of the EP terminals

The function of the EP terminals for pulse inhibit is only available if the "Safety Integrated Basic Functions via onboard terminals" software is enabled.

Temperature sensor connection

NOTICE

Damage to motor in the event of incorrectly connected KTY temperature sensor

A KTY temperature sensor connected with incorrect polarity cannot detect if the motor overheats. Overheating can cause damage to the motor.

- Connect the KTY temperature sensor with the correct polarity.

Note

The temperature sensor input is not needed if the motors feature an integrated DRIVE-CLiQ interface or if temperature values are detected by means of a different module (SMC, SME, TM).



! WARNING

Electric shock in the event of voltage flashovers at the temperature sensor

Voltage flashovers in the signal electronics can occur in motors without safe electrical separation of the temperature sensors.

- Use temperature sensors that comply with the specifications relating to protective separation.
- If safe electrical separation cannot be guaranteed (for linear motors or third-party motors, for example), use a Sensor Module External (SME120 or SME125) or Terminal Module TM120.

6.4.2.4 X200-X203 DRIVE-CLiQ interface

Table 6- 35 X200-X202: DRIVE-CLiQ interfaces for Single Motor Modules
X200-X203: DRIVE-CLiQ interfaces for Double Motor Modules

	Pin	Name	Technical data
	1	TXP	Transmit data +
	2	TXN	Transmit data -
	3	RXP	Receive data +
	4	Reserved, do not use	-
	5	Reserved, do not use	-
	6	RXN	Receive data -
	7	Reserved, do not use	-
	8	Reserved, do not use	-
	A	+ (24 V)	Power supply
	B	M (0 V)	Electronics ground

The blanking covers for the DRIVE-CLiQ interfaces are included in the scope of delivery.

Blanking cover (50 pcs.) Article number: 6SL3066-4CA00-0AA0

6.4.3 Connection examples

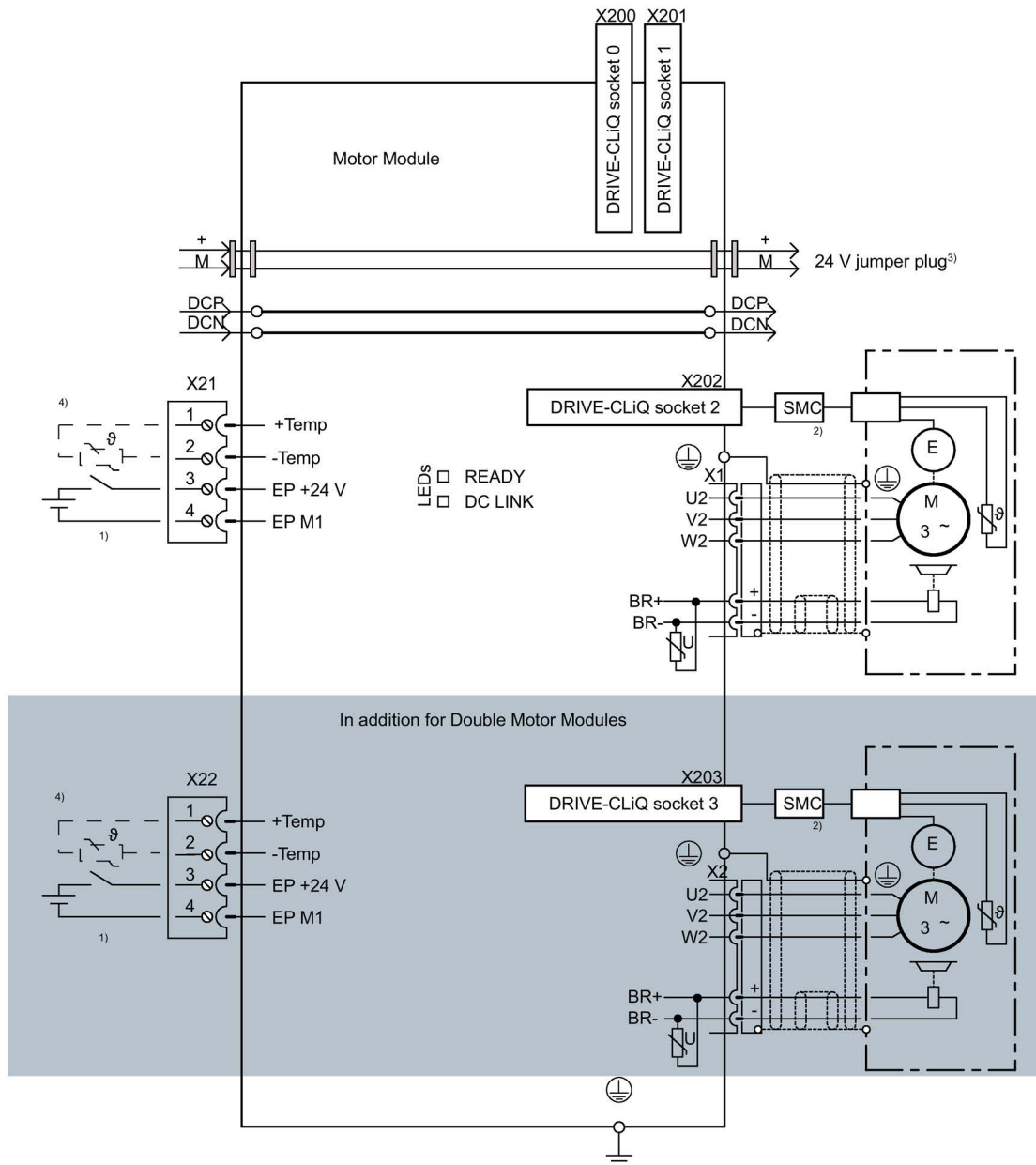

- 1) Required for safety
- 2) SMC required for motors without DRIVE-CLiQ interface
- 3) 24 V to the next module
- 4) Optional, e.g. for motor without encoder

Figure 6-65 Connection example of Motor Modules 3 A to 30 A and Double Motor Modules 2 x 3 A to 2 x 18 A

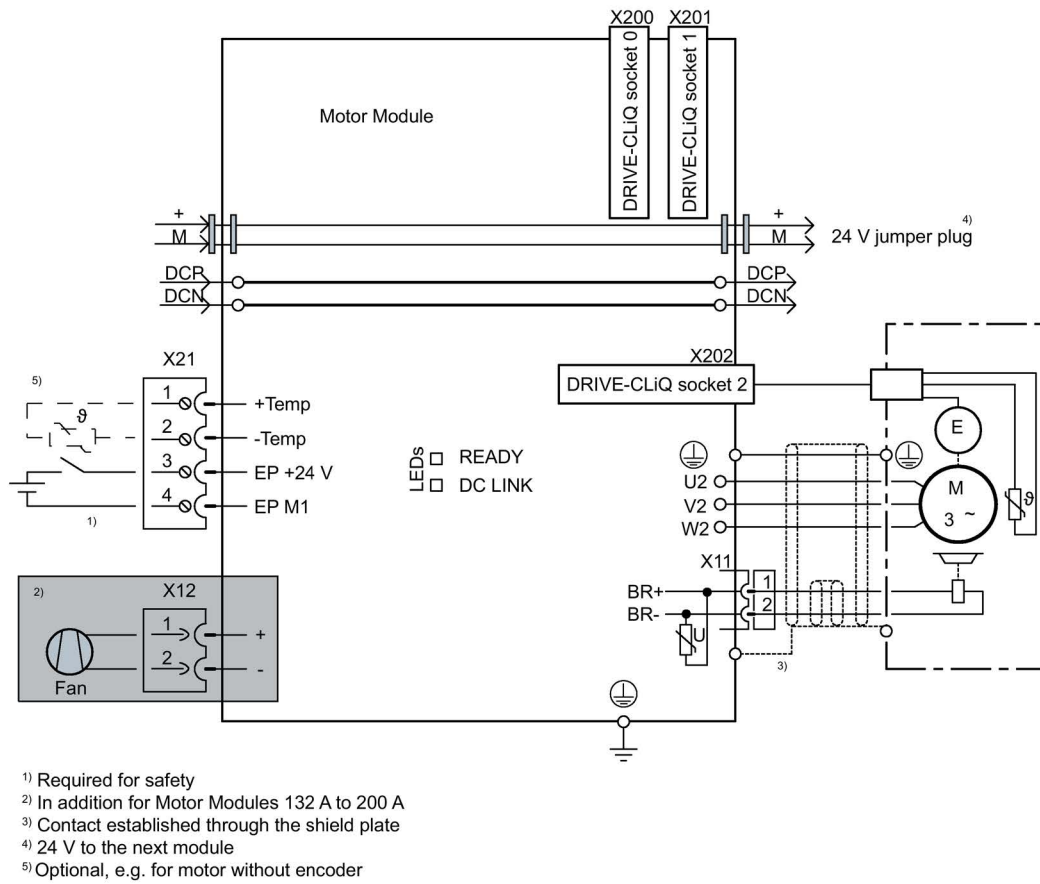

Figure 6-66 Example connection of Single Motor Modules 45 A to 200 A

6.4.4 Meaning of LEDs

Table 6- 36 Meaning of the LEDs on the Motor Module

Status		Description, cause	Remedy
RDY	DC LINK		
Off	Off	The electronics power supply is missing or outside the permissible tolerance range.	–
Green	-- ¹⁾	The component is ready for operation. Cyclic DRIVE-CLiQ communication is taking place.	–
	Orange	The component is ready for operation. Cyclic DRIVE-CLiQ communication is taking place. The DC link voltage is present.	–
	Red	The component is ready for operation. Cyclic DRIVE-CLiQ communication is taking place. The DC link voltage is outside the permissible tolerance range.	Check the line supply voltage.
Orange	Orange	DRIVE-CLiQ communication is being established.	–
Red	-- ¹⁾	This component has at least one fault.	Resolve and acknowledge the fault.
Green/red (0.5 Hz)	-- ¹⁾	Firmware is being downloaded.	–
Green/red (2 Hz)	-- ¹⁾	Firmware download has been completed. The system waits for POWER ON.	Carry out a POWER ON.
Green/orange or red/orange	-- ¹⁾	Component recognition via LED is activated ²⁾ . Note: Both options depend on the LED status when component recognition is activated.	–

1) Irrespective of the status of the LED "DC LINK"

2) For information about activating the parameter "Recognition via LED", see SINAMICS S120/S150 List Manual

6.4.5 Dimension drawings

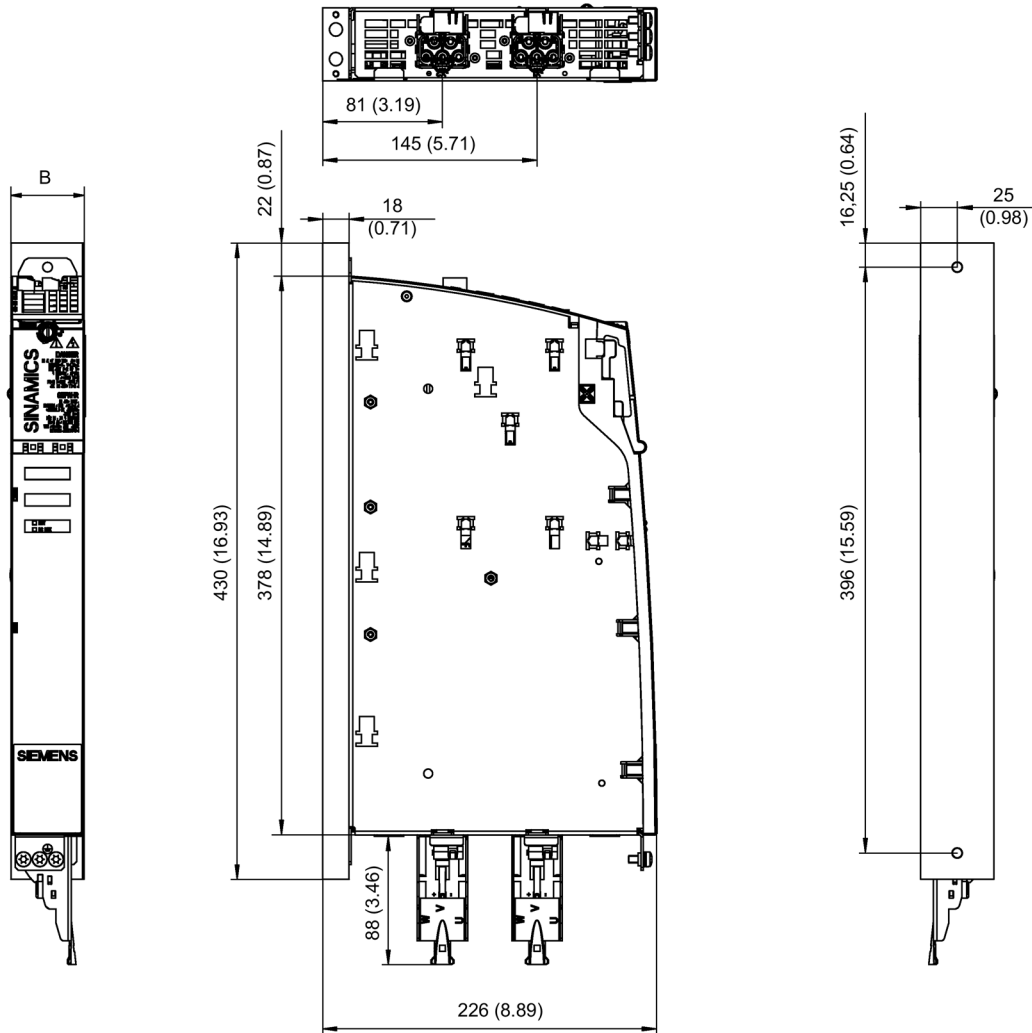

Figure 6-67 Dimension drawing of 3 A to 18 A and 2 x 3 A to 2 x 9 A Motor Modules Booksize with cold plate, all dimensions in mm and (inches); example: 2 x 5 A Double Motor Module

Table 6- 37 Dimensions of 3 A to 18 A and 2 x 3 A to 2 x 9 A Motor Modules Booksize with cold plate

Motor Module	Article No.	B [mm] (inch)
3 A Single Motor Module	6SL3126-1TE13-0AA.	50 (1.97)
5 A Single Motor Module	6SL3126-1TE15-0AA.	
9 A Single Motor Module	6SL3126-1TE21-0AA.	
18 A Single Motor Module	6SL3126-1TE21-8AA.	
Double Motor Module 2 x 3 A	6SL3126-2TE13-0AA.	
Double Motor Module 2 x 5 A	6SL3126-2TE15-0AA.	
Double Motor Module 2 x 9 A	6SL3126-2TE21-0AA.	

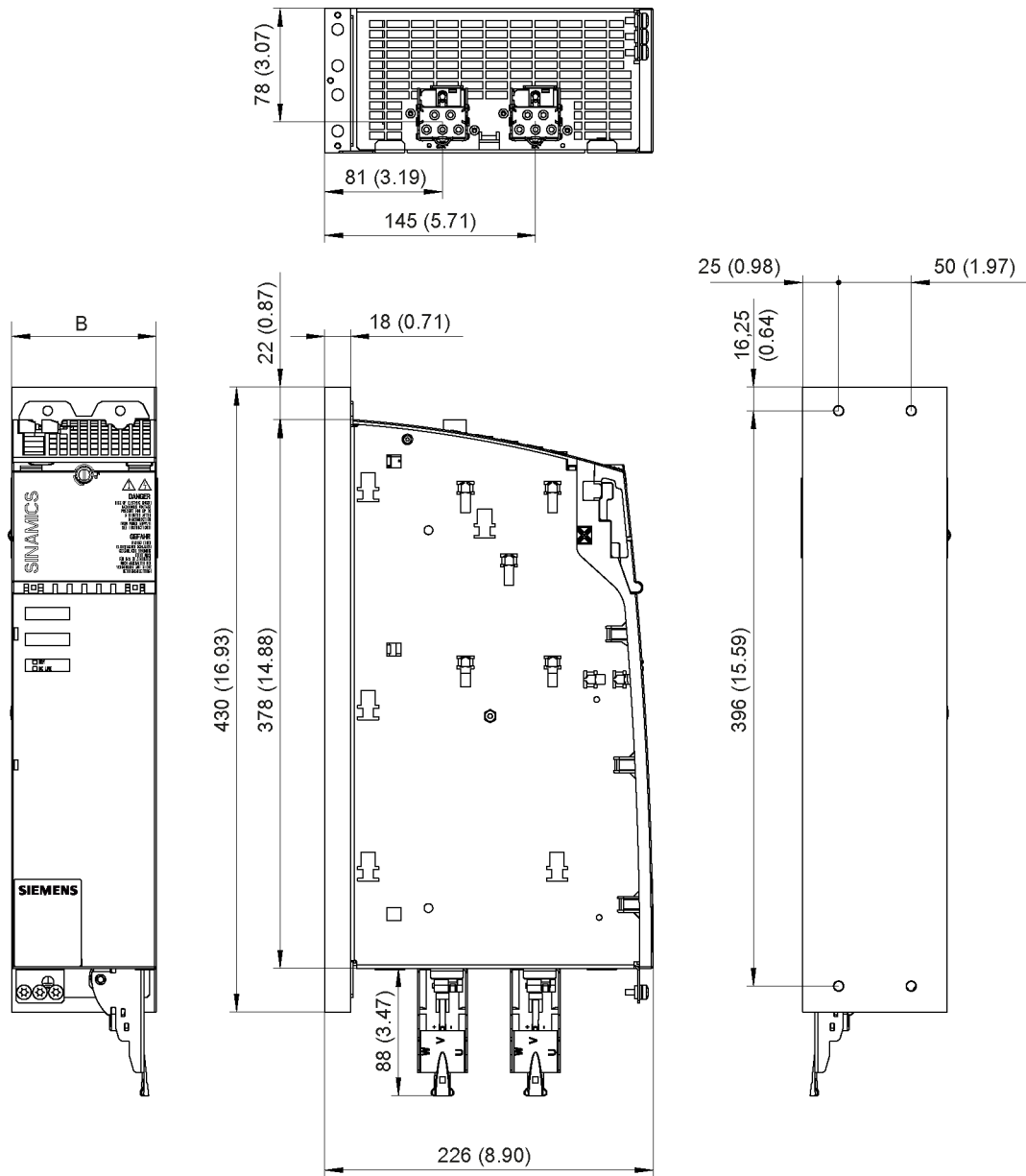

Figure 6-68 Dimension drawing of 30 A and 2 x 18 A Motor Modules Booksize with cold plate, all dimensions in mm and (inches)

Table 6- 38 Dimensions of 30 A and 2 x 18 A Motor Modules Booksize with cold plate

Motor Module	Article No.	B [mm] (inch)
30 A Single Motor Module	6SL3126-1TE23-0AA.	100 (3.94)
Double Motor Module 2 x 18 A	6SL3126-2TE21-8AA.	

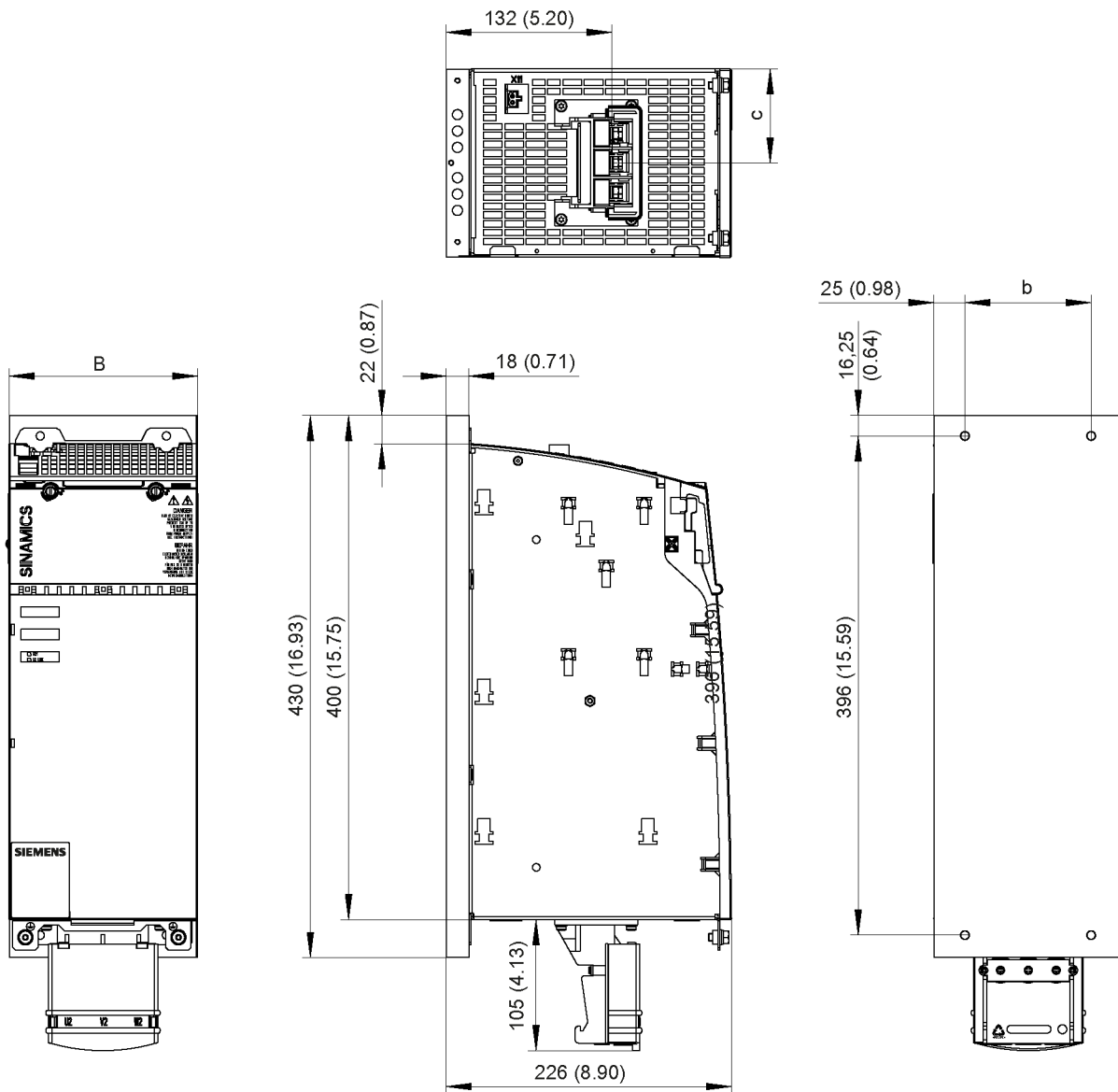

Figure 6-69 Dimension drawing of Motor Modules Booksize 45 A, 60 A, and 85 A with cold plate, all dimensions in mm and (inches); example for Motor Module 45 A

Table 6- 39 Dimensions of 45 A, 60 A, and 85 A Motor Modules Booksize with cold plate

Motor Modules	Article No.	B [mm] (inch)	b [mm] (inch)	c [mm] (inch)
Single Motor Module 45 A	6SL3126-1TE24-5AA.	150 (5.91)	100 (3.94)	75 (2.95)
Single Motor Module 60 A	6SL3126-1TE26-0AA.			
Single Motor Module 85 A	6SL3126-1TE28-5AA.	200 (7.87)	150 (5.91)	100 (3.94)

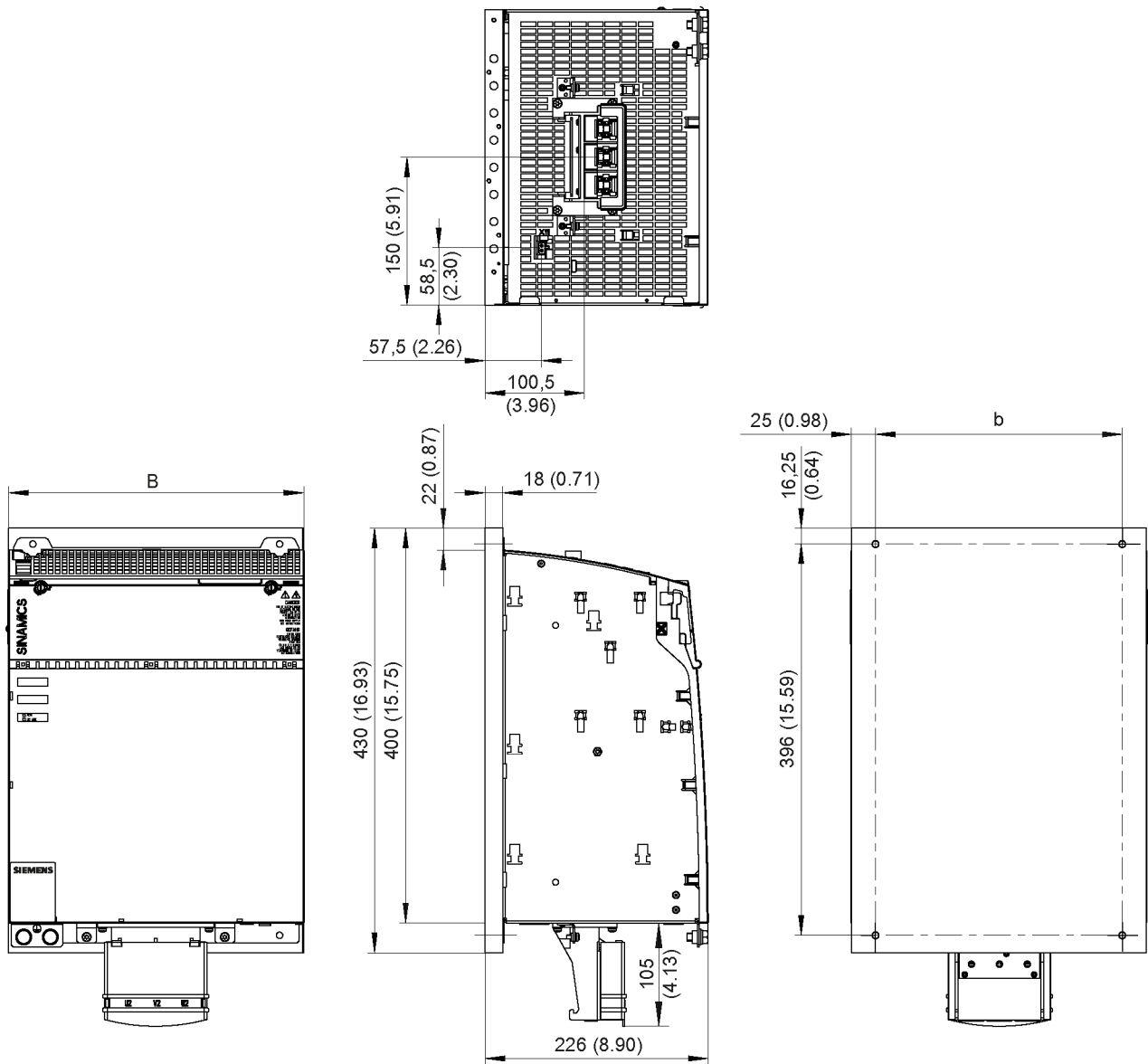

Figure 6-70 Dimension drawing of Motor Modules Booksize 132 A and 200 A with cold plate, all dimensions in mm and (inches); example for Motor Module 200 A

Table 6- 40 Dimensions of 132 A and 200 A Motor Modules Booksize with cold plate

Motor Module	Article No.	B [mm] (inch)	b [mm] (inch)
Single Motor Module 132 A	6SL3126-1TE31-3AA.	300 (11.81)	250 (9.84)
Single Motor Module 200 A	6SL3126-1TE32-0AA.		

6.4.6 Mounting

Please note the following before mounting a Motor Module with cold plate on a customer-specific heat sink:

- Check the surface of the heat sink to ensure that it is not damaged.
- To improve heat transfer, a heat-conducting medium must be used. Special spherical-indented heat-conducting foil must be used for this purpose. Every component with cold plate is supplied with heat-conducting foil cut to the right size. Note the mounting position of the heat-conducting foil (see diagram below).

Note

- Also replace the heat-conducting foil when replacing a component.
 - Only use heat-conducting foil released or supplied by Siemens.
-

Table 6- 41 Overview of heat-conducting foils

	Article No.
Heat-conducting foil, 50 mm	6SL3162-6FB00-0AA0
Heat-conducting foil, 100 mm	6SL3162-6FD00-0AA0
Heat-conducting foil, 150 mm	6SL3162-6FF00-0AA0
Heat-conducting foil, 200 mm	6SL3162-6FH00-0AA0
Heat-conducting foil, 300 mm	6SL3162-6FM00-0AA0

Note

To mount the components, M6 threaded bolts and hexagon nuts/grub screws ISO 7436-M6x40-14 H, property class 8.8 are recommended.

Installation

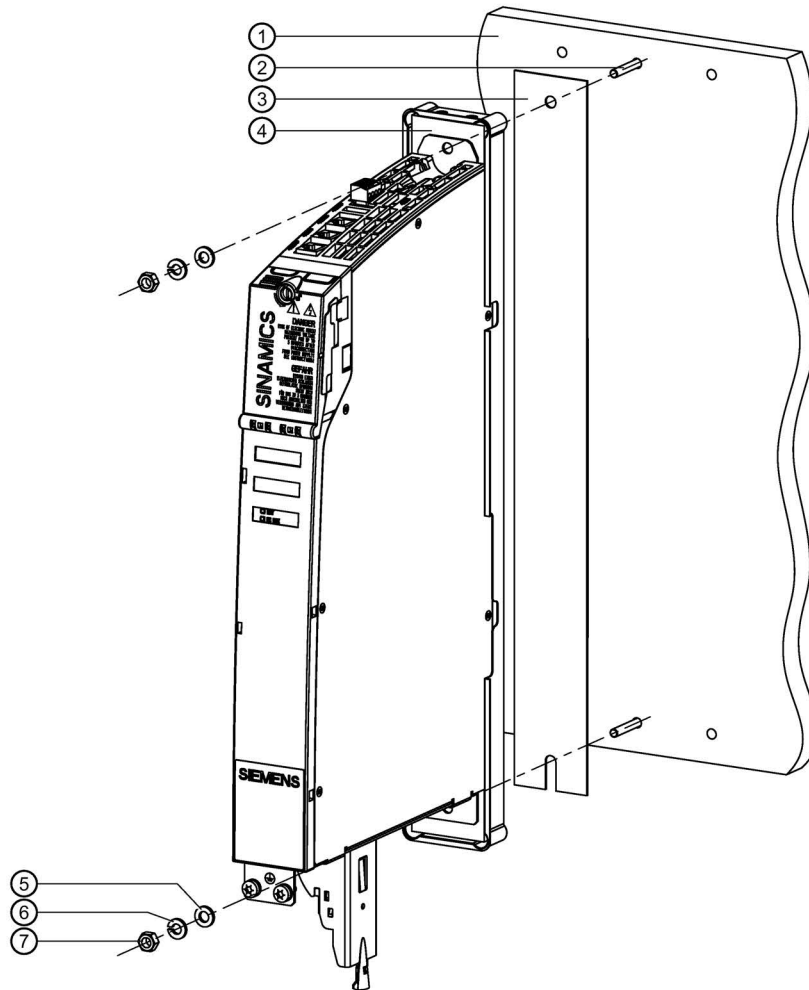

- ① External heat sink (air or liquid)
- ② Threaded bolts M6
- ③ Heat-conducting foil
- ④ Cold plate
- ⑤ Washer
- ⑥ Spring washer
- ⑦ M6 nut

Figure 6-71 Mounting a Motor Module with cold plate on an external heat sink (example: 3 A Motor Module)

Tightening torques:

1. Firstly, tighten the nuts by hand.
Tightening torque: 0.5 Nm (4.4 lbf in)
2. Then tighten the nuts.
Tightening torque: 10 Nm (88.5 lbf in)

Note

- Where components have four fixing points, the nuts must be tightened evenly by alternating diagonally between them.
-

Support with the mechanical control cabinet design is available from:

Siemens AG
Digital Factory, DF MC MF - WKC AS
TCCCC (Technical Competence Center Cabinets Chemnitz)
Postfach 1124
09070 Chemnitz
e-mail: cc.cabinetcooling.aud@siemens.com

Properties of the heat sink

We recommend using AlMgSi 0.5 as the heat sink material.
The roughness of the external heat sink surface should be at least Rz 16. The contact surface between the heat sink and cold plate should have an evenness of 0.2 mm (applicable to a height of 450 mm and a width of 300 mm).

Note

Machine manufacturers can adapt the heat sink version to their special requirements. The specified rated data for the Motor Modules can only be achieved if the power losses can be dissipated by the external heat sink under the specified general conditions.

NOTICE
Damage to the cold plate caused by incorrect mounting
The threaded bolts can damage the cold plate when it is being mounted.
<ul style="list-style-type: none">• Do not damage the cold plate.

6.4.7 Technical data

6.4.7.1 Single Motor Modules

Table 6- 42 Technical data Single Motor Modules Booksize (3 to 30 A)

Cold plate	6SL3126-	1TE13-0AA. ¹⁾	1TE15-0AA. ¹⁾	1TE21-0AA. ¹⁾	1TE21-8AA. ¹⁾	1TE23-0AA.
Output current (at 600 V DC)						
Rated current (I _n)	A _{AC}	3	5	9	18	30
Base-load current (I _H)	A	2.6	4.3	7.7	15.3	25.5
Intermittent duty current (I _{s6}) 40%	A _{AC}	3.5	6	10	24	40
Peak current (I _{max})	A _{AC}	6	10	18	36	56
Output voltage	V _{AC}	0 ... 0.717 x DC-link voltage				
DC link current	A _{DC}	3.6	6	11	22	36
DC-link voltage (up to 2000 m above sea level)	V _{DC}	510 ... 720				
DC link capacitance	μF	110	110	110	220	710
Overvoltage trip	V _{DC}	820 ± 2 %				
Undervoltage trip ²⁾	V _{DC}	380 ± 2 %				
Electronics power supply	V _{DC}	24 (20.4 ... 28.8)				
Electronics current consumption at 24 V DC	A _{DC}	0.65				
Current carrying capacity						
DC link busbars	A _{DC}	100				
Reinforced DC link busbars	A _{DC}	150				
24 V DC busbars	A _{DC}	20				
Unit rating³⁾						
Based on I _n (600 VDC; 4 kHz)	kW	1.6	2.7	4.8	9.7	16
Based on I _H	kW	1.1	2.3	4.1	8.2	13.7
Total power loss (including electronics losses, see Power loss tables (Page 734))	W	45.5	70.6	95.6	180.6	305.6
Max. pulse frequency without derating	kHz	4				
with derating	kHz	16				
Output frequency	Hz	0 ... 550				
Max. permissible heat sink temperature	°C	80	80	80	80	70
Ventilation clearances above/below	mm	≥ 80				
Weight	kg	4.2	4.2	4.5	4.5	6.1

1) Applies only to Article numbers with "." = 0 ... 3

2) Default for 400 V line systems; undervoltage trip threshold can be reduced by up to 80 V and is adjusted to the parameterized rated voltage

3) Rated power of a typical standard induction motor at 400 V 3 AC

Table 6- 43 Technical data Single Motor Modules (45A to 200A)

Cold plate	6SL3126-	1TE24-5AA.	1TE26-0AA.	1TE28-5AA.	1TE31-3AA.	1TE32-0AA.
Output current (at 600 V DC)						
Rated current (I_n)	A_{AC}	45	60	85	132 (105) ¹⁾	200 (140) ¹⁾
Base-load current (I_H)	A	38	51	68	105 (84) ¹⁾	141 (99) ¹⁾
Intermittent duty current (I_{S6})	A_{AC}	60	80	110	150 (120) ¹⁾	230 (161) ¹⁾
40%	A_{AC}	85	113	141	210	282
Peak current (I_{max})						
Output voltage	V_{AC}	0 ... 480				
DC link current	A_{DC}	54	72	102	158	200
DC-link voltage (up to 2000 m above sea level)	V_{DC}	510 ... 720				
DC link capacitance	μF	1175	1410	1880	2820	3995
Overvoltage trip Undervoltage trip ²⁾	V_{DC} V_{DC}	820 \pm 2 % 380				
Electronics power supply	V_{DC}	24 (20.4 ... 28.8)				
Electronics current consumption at 24 V DC	A_{DC}	0.75	0.75	0.8	0.85	0.85
Current carrying capacity						
DC link busbars	A_{DC}	200				
24 V DC busbars	A_{DC}	20				
Unit rating³⁾						
Based on I_n (600 VDC; 4 kHz)	kW	24	32	46	71 (57) ¹⁾	107 (75) ¹⁾
Based on I_H	kW	21	28	37	57 (46) ¹⁾	76 (53) ¹⁾
Total power loss (including electronics losses, see Power loss tables (Page 734))	W	448	608	769.2	1270.4	2070.4
Max. pulse frequency						
without derating	kHz	4				
with derating	kHz	16				
Output frequency	Hz	0 ... 550				
Max. permissible heat sink temperature	$^{\circ}C$	80	73	83	75	79 (70% derating)
Ventilation clearances						
above/below	mm	≥ 80				
in front of the component	mm	---				
		≥ 80				
		≥ 50				
Weight	kg	9.0	9.4	12.8	18.0	18.6

- 1) Derating must be applied due to the transfer of heat to the external heat sink. At a temperature of 40° C at the interface to the power unit, 80% derating occurs for 6SL3126-1TE31-3AA. and 70 % for 6SL3126-1TE32-0AA.
- 2) Default for 400 V line systems; undervoltage trip threshold can be reduced by up to 80 V (exception: 132 A and 200 A Motor Modules) and is adjusted to the parameterized rated voltage.
- 3) Rated power of a typical standard induction motor at 400 V 3 AC

Note

New systems with 132 A and 200 A Motor Modules should ideally be designed with 200 A liquid-cooled Motor Modules in order to avoid current derating.

6.4.7.2 Double Motor Modules

Table 6- 44 Technical data Double Motor Modules (2 x 3 to 2 x 18 A)

Cold plate	6SL3126-	2TE13-0AA. ¹⁾	2TE15-0AA. ¹⁾	2TE21-0AA. ¹⁾	2TE21-8AA.
Output current (at 600 V DC)					
Rated current (I _n)	A _{AC}	2 x 3	2 x 5	2 x 9	2 x 18
Base-load current (I _H)	A	2 x 2.6	2 x 4.3	2 x 7.7	2 x 15.3
Intermittent duty current (I _{S6}) 40%	A _{AC}	2 x 3.5	2 x 6	2 x 10	2 x 24
Peak current (I _{max})	A _{AC}	2 x 6	2 x 10	2 x 18	2 x 36
Output voltage	V _{AC}	0 ... 480			
DC link current	A _{DC}	7.2	12	22	43
DC-link voltage	V _{DC}	510 ... 720			
DC link capacitance	μF	110	220	220	705
Overvoltage trip	V _{DC}	820 ± 2 %			
Undervoltage trip ²⁾	V _{DC}	380 ± 2 %			
Electronics power supply	V _{DC}	24 (20.4 ... 28.8)			
Electronics current consumption at 24 V DC	A _{DC}	0.9	0.9	0.9	1.05
Current carrying capacity					
DC link busbars	A _{DC}	100	100	100	100
Reinforced DC link busbars	A _{DC}	150	150	150	150
24 V DC busbars	A _{DC}	20	20	20	20
Unit rating³⁾					
Based on I _n (600 VDC; 4 kHz)	kW	2 x 1.6	2 x 2.7	2 x 4.8	2 x 9.7
Based on I _H	kW	2 x 1.4	2 x 2.3	2 x 4.1	2 x 8.2
Total power loss (including electronics losses, see Power loss tables (Page 734))	W	91.6	126.6	181.6	345.2
Max. pulse frequency					
without derating	kHz	4			
with derating	kHz	16			
Output frequency	Hz	0 ... 550			
Max. permissible heat sink temperature	°C	80	80	90	90
Ventilation clearances above/below	mm	≥ 80			
Weight	kg	4.5	4.5	4.5	5.9

1) Applies only to Article numbers with "." = 0 ... 3

2) Default for 400 V line systems; undervoltage trip threshold can be reduced by up to 80 V and is adjusted to the parameterized rated voltage

3) Rated power of a typical standard induction motor at 400 V 3 AC

6.4.7.3 Characteristics

Rated duty cycles Motor Modules Booksize

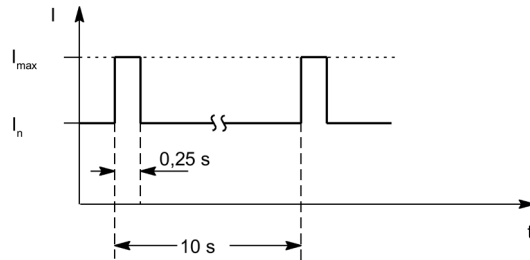

Figure 6-72 Duty cycle with initial load (for servo drives)

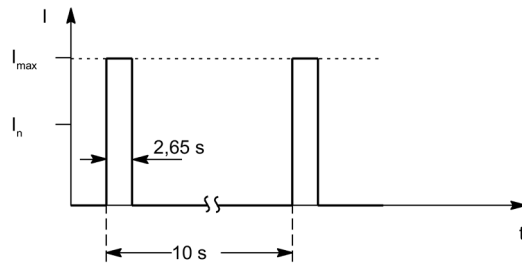

Figure 6-73 Duty cycle without initial load (for servo drives)

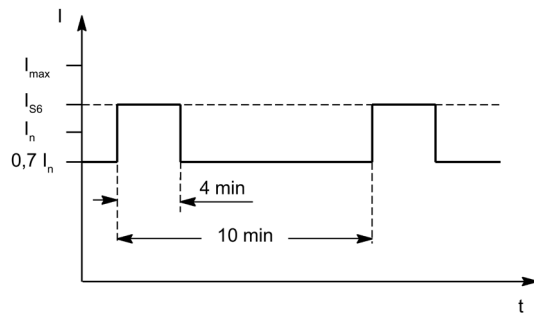

Figure 6-74 S6 duty cycle with initial load with a duty cycle duration of 600 s (for servo drives)

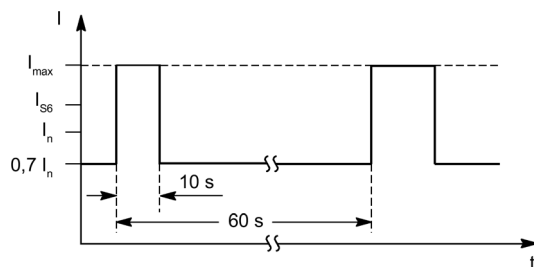

Figure 6-75 S6 duty cycle with initial load with a duty cycle duration of 60 s (for servo drives)

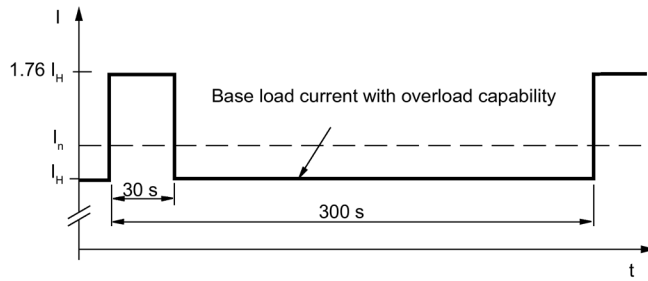

Figure 6-76 Duty cycle with 30 s overload for a duty cycle duration of 300 s

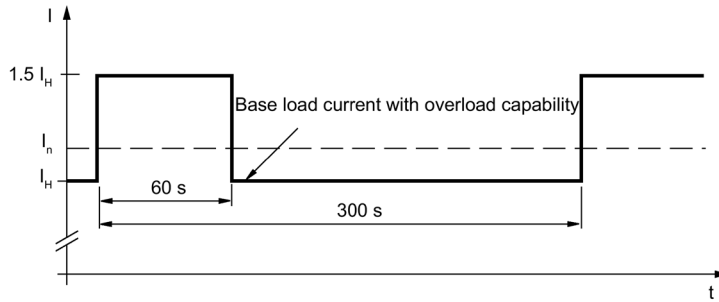

Figure 6-77 Duty cycle with 60 s overload for a duty cycle duration of 300 s

Derating characteristics for Motor Modules Booksize

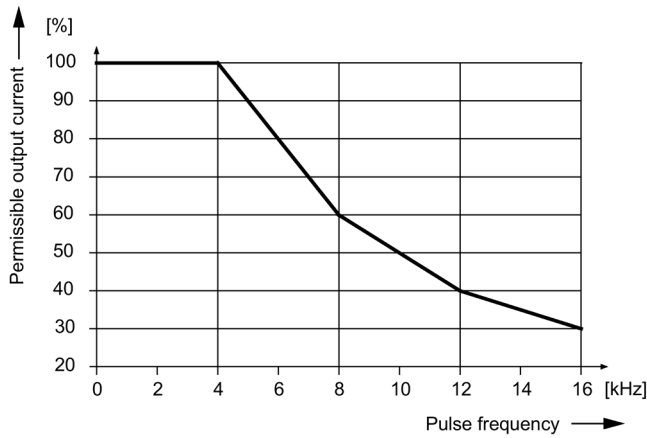

Figure 6-78 Output current as a function of the pulse frequency

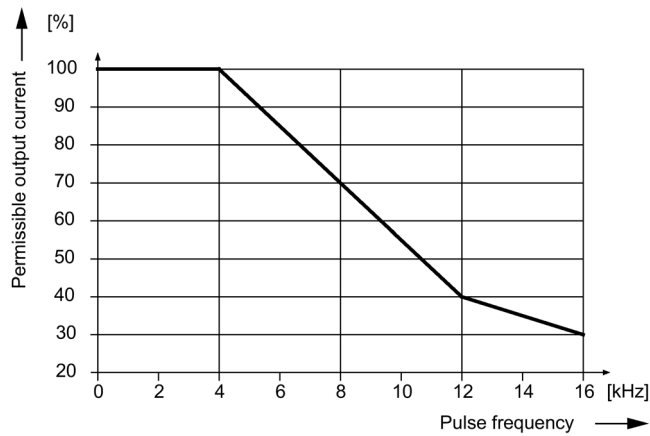

Figure 6-79 Output current as a function of the pulse frequency for 200 A Motor Modules (applies from Article number 6SL312.-1TE32-0AA4)

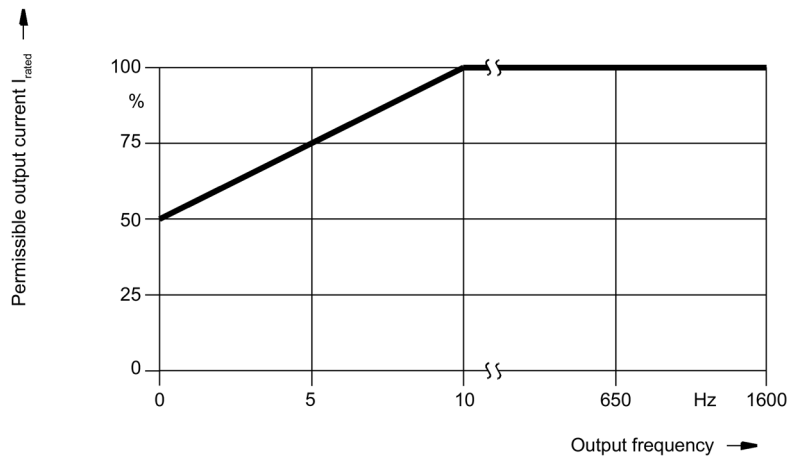

Figure 6-80 Output current at low frequencies

Dimensioning notes:

- A current derating is only applicable for output frequencies < 10 Hz.
- Current derating should be taken into account if the percentage time of operation at frequencies < 10 Hz is more than 2 % of the daily total operating time.
- Also during load cycles, the current specified here must not be exceeded.
- When quickly passing through frequencies 0 to 10 Hz, derating does not have to be taken into account (e.g. for positioning applications).

Note

Information about derating the output current as a function of the ambient temperature and installation altitude is provided in Chapter "System data (Page 42)".

6.4.8 Technical data for Motor Modules Booksize with 300% overload

6.4.8.1 Single Motor Modules (300% overload)

Table 6- 45 Technical data Single Motor Modules (3 to 18 A) with 3-fold overload

Cold plate	6SL3126-	1TE13-0AA4	1TE15-0AA4	1TE21-0AA4	1TE21-8AA4
Output current (at 600 V DC)					
Rated current (I _n)	A _{AC}	3	5	9	18
Base-load current (I _H)	A	2.6	4.3	7.7	15.3
Intermittent duty current (I _{s6}) 40%	A _{AC}	3.5	6	10	24
Peak current (I _{max})	A _{AC}	9	15	27	54
Output voltage	V _{AC}	0 ... 0.717 x DC-link voltage			
DC link current	A _{DC}	3.6	6	11	22
DC-link voltage (up to 2000 m above sea level)	V _{DC}	510 ... 720			
DC link capacitance	μF	110	110	110	220
Overvoltage trip	V _{DC}	820 ± 2 %			
Undervoltage trip ¹⁾	V _{DC}	380 ± 2 %			
Electronics power supply	V _{DC}	24 (20.4 ... 28.8)			
Electronics current consumption at 24 V DC	A _{DC}	0.65			
Current carrying capacity					
DC link busbars	A _{DC}	100			
Reinforced DC link busbars	A _{DC}	150			
24 V DC busbars	A _{DC}	20			
Unit rating²⁾					
Based on I _n (600 VDC; 4 kHz)	kW	1.6	2.7	4.8	9.7
Based on I _H	kW	1.1	2.3	4.1	8.2
Total power loss (including electronics losses, see Power loss tables (Page 734))	W	45.5	70.6	95.6	180.6
Max. pulse frequency without derating	kHz	4			
with derating	kHz	16			
Output frequency	Hz	0 ... 550			
Max. permissible heat sink temperature	°C	70	70	70	70
Ventilation clearances above/below	mm	≥ 80			
Weight	kg	4.2	4.2	4.5	4.5

1) Default for 400 V line systems; undervoltage trip threshold can be reduced by up to 80 V and is adjusted to the parameterized rated voltage

2) Rated power of a typical standard induction motor at 400 V 3 AC

Note

Operation of 18 A Single Motor Modules with 3-fold overload connected to a 16 kW Line Module

The maximum power of a 16 kW Line Module is not sufficient for operating 18 A Single Motor Modules at their peak current.

- Take the motor power into consideration if you wish to operate an 18 A Single Motor Module on a 16 kW Line Module. Depending on the operating state, the power consumption of these Single Motor Modules can be > 35 kW, and it may be necessary to install a Line Module with a higher power rating for applications such as these.

6.4.8.2 Double Motor Modules (300% overload)

Table 6- 46 Technical data Double Motor Modules (2 x 3 to 2 x 9 A) with 3-fold overload

Cold plate	6SL3126-	2TE13-0AA4	2TE15-0AA4	2TE21-0AA4
Output current (at 600 V DC)				
Rated current (I_n)	A_{AC}	2 x 3	2 x 5	2 x 9
Base-load current (I_H)	A	2 x 2.6	2 x 4.3	2 x 7.7
Intermittent duty current (I_{S6}) 40%	A_{AC}	2 x 3.5	2 x 6	2 x 10
Peak current (I_{max})	A_{AC}	2 x 9	2 x 15	2 x 27
Output voltage	V_{AC}	0 ... 480		
DC link current	A_{DC}	7.2	12	22
DC-link voltage (up to 2000 m above sea level)	V_{DC}	510 ... 720		
DC link capacitance	μF	110	220	220
Overvoltage trip	V_{DC}	820 \pm 2 %		
Undervoltage trip ¹⁾	V_{DC}	380		
Electronics power supply	V_{DC}	24 (20.4 ... 28.8)		
Electronics current consumption at 24 V DC	A_{DC}	0.9	0.9	0.9
Current carrying capacity				
DC link busbar	A_{DC}	100	100	100
Reinforced DC link busbars	A_{DC}	150	150	150
24 V busbar	A_{DC}	20	20	20
Unit rating²⁾				
Based on I_n (600 VDC; 4 kHz)	kW	2 x 1.6	2 x 2.7	2 x 4.8
Based on I_H	kW	2 x 1.4	2 x 2.3	2 x 4.1
Total power loss (including electronics losses, see Power loss tables (Page 734))	W	91.6	126.6	181.6
Max. pulse frequency				
without derating	kHz	4		
with derating	kHz	16		
Output frequency	Hz	0 ... 550		
Max. permissible heat sink temperature	$^{\circ}C$	77	77	77

Cold plate	6SL3126-	2TE13-0AA4	2TE15-0AA4	2TE21-0AA4
Ventilation clearances above/below	mm	≥ 80		
Weight	kg	4.5	4.5	4.5

- 1) Default for 400 V line systems; undervoltage trip threshold can be reduced by up to 80 V and is adjusted to the parameterized rated voltage
- 2) Rated power of a typical standard induction motor at 400 V 3 AC

Note

Disturbance of the 2 x 9 A Double Motor Module with 3-fold overload on a 16 kW Line Module

The maximum output of a 16 kW Line Module is not sufficient for the operation of a 2 x 9 A Double Motor Module with 3-fold overload.

- Do NOT operate a 2 x 9 A Double Motor Module with a 16 kW Line Module with 3-fold overload (i.e. only operate a 2 x 9 A Double Motor Module with a 16 kW Line Module, if the maximum current is limited to $2 \times I_{rated}$).
- Use at least a 36 kW Active Line Module or Smart Line Module for operation with 3-fold overload.

6.4.8.3 Characteristics for Motor Modules Booksize with 300% overload

Rated duty cycles Motor Modules Booksize with 300% overload

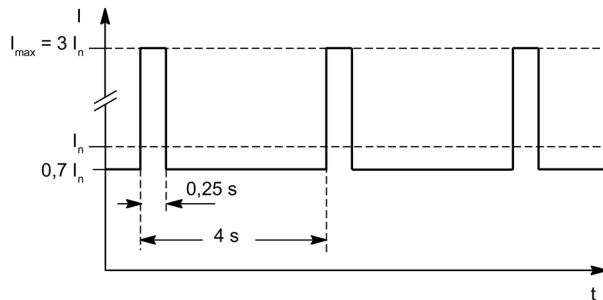

Figure 6-81 Peak current duty cycle with initial load (300% overload)

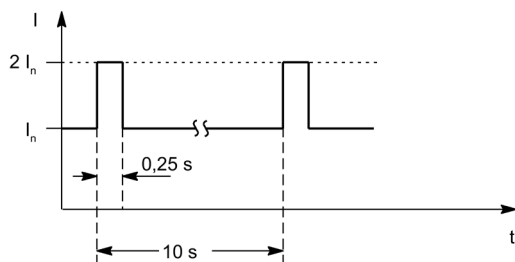

Figure 6-82 Duty cycle with initial load

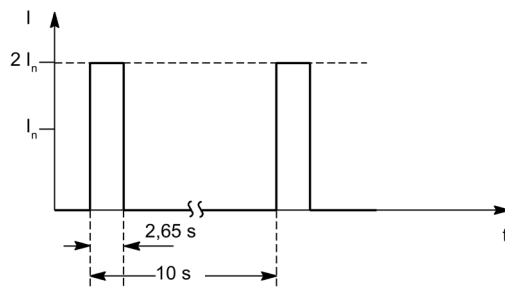

Figure 6-83 Duty cycle without initial load

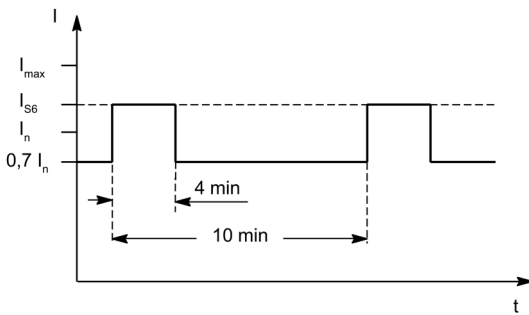

Figure 6-84 S6 duty cycle with initial load for a duty cycle duration of 600 s

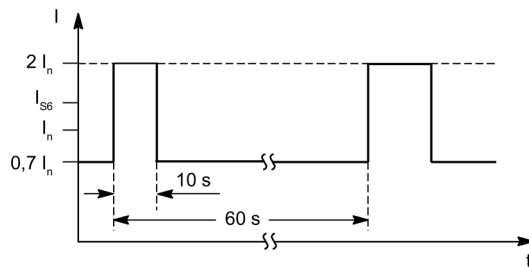

Figure 6-85 S6 duty cycle with initial load for a duty cycle duration of 60 s

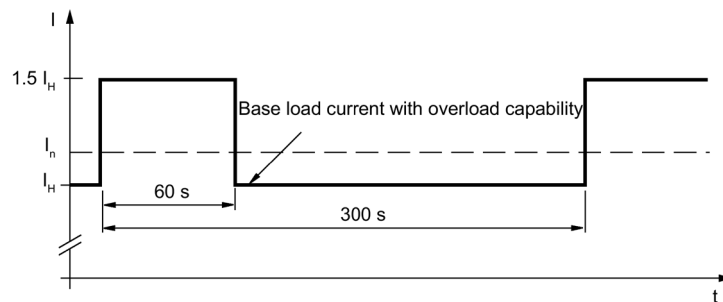

Figure 6-86 Duty cycle with 60 s overload for a duty cycle duration of 300 s

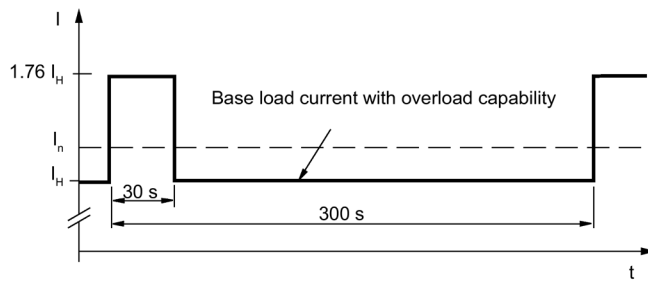

Figure 6-87 Duty cycle with 30 s overload for a duty cycle duration of 300 s

Derating characteristics for Motor Modules Booksize with 300% overload

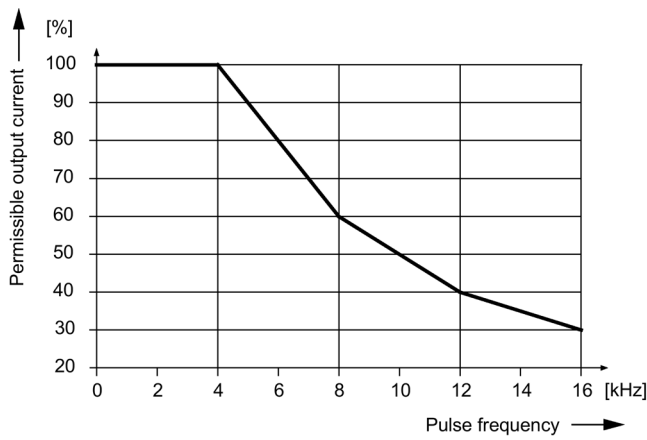

Figure 6-88 Output current as a function of the pulse frequency

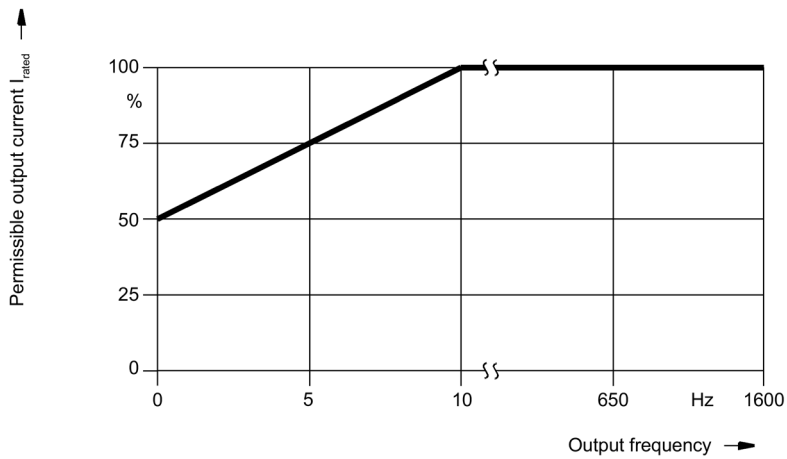

Figure 6-89 Output current at low frequencies

Dimensioning notes:

- A current derating is only applicable for output frequencies < 10 Hz.
- Current derating should be taken into account if the percentage time of operation at frequencies < 10 Hz is more than 2 % of the daily total operating time.
- Also during load cycles, the current specified here must not be exceeded.
- When quickly passing through frequencies 0 to 10 Hz, derating does not have to be taken into account (e.g. for positioning applications).

Note

Information about derating the output current as a function of the ambient temperature and installation altitude is provided in Chapter "System data (Page 42)".

6.5 Motor Modules Liquid Cooled

6.5.1 Description

A Motor Module is a power unit (inverter) that provides the power for the connected motor or motors. Power is supplied by the DC link of the drive unit. A Motor Module must be connected to a Control Unit via DRIVE-CLiQ. The open-loop and closed-loop control functions for the Motor Module are stored in the Control Unit.

6.5.2 Interface description

6.5.2.1 Overview

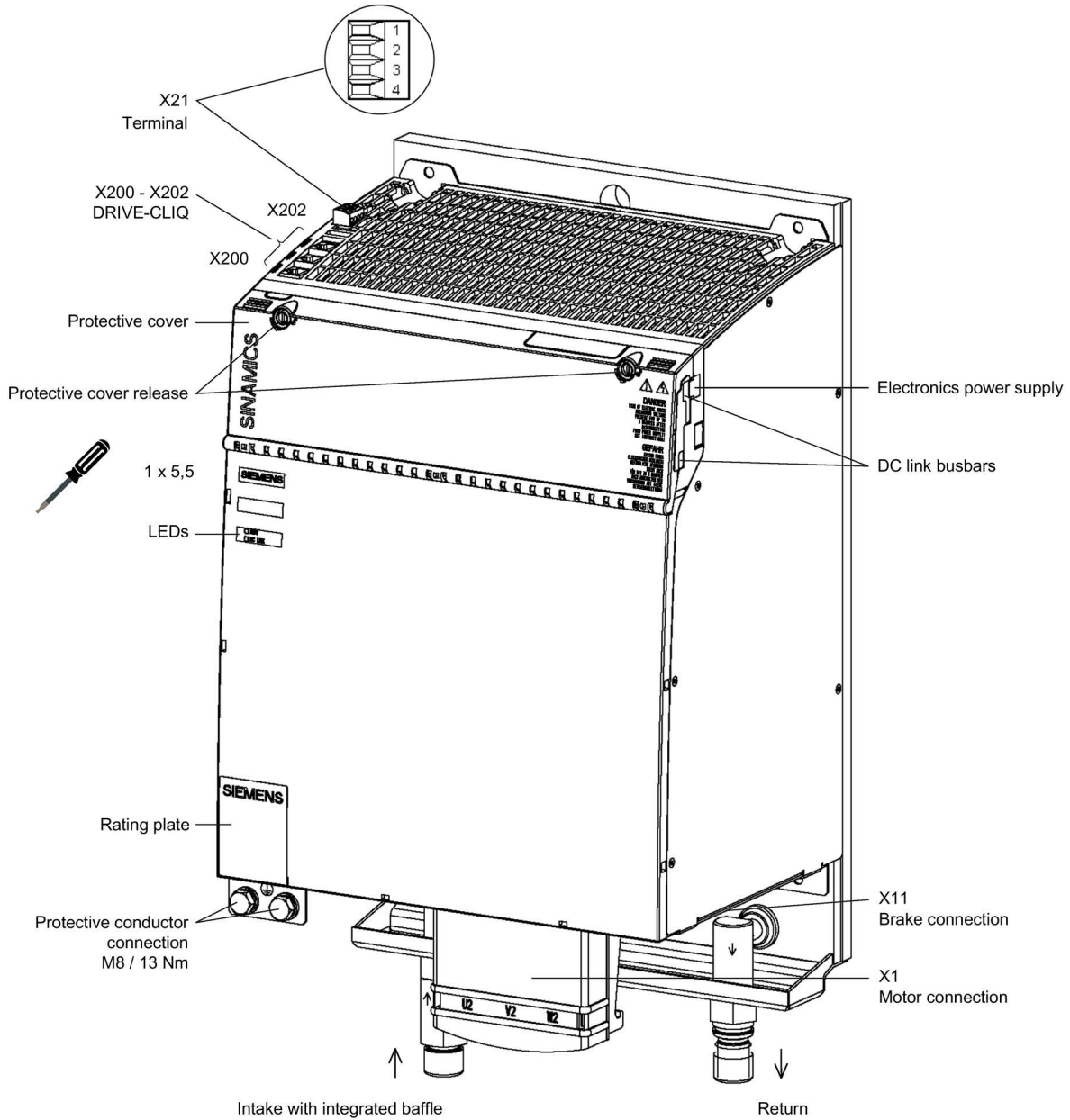

Figure 6-90 Interface overview, Motor Module Liquid Cooled (200 A)

6.5.2.2 Motor and brake connection

Table 6- 47 X1 Motor connection

	Terminal	Technical data
	U2	Threaded bolt M8 / 13 Nm (115 lbf in) ¹⁾
	V2	
	W2	
	- (BR-)	
	Protective conductor connection	Threaded hole M8 / 13 Nm (115 lbf in) ¹⁾
¹⁾ For ring cable lugs without insulation (Page 710)		

Table 6- 48 X11 brake connector

	Terminal	Technical data
	+ (BR+)	Voltage 24 V DC Max. Load current 2 A Minimum load current 0.1 A Type: Spring-loaded terminal 2 (Page 708) The brake connector is part of the prefabricated cable.
	- (BR-)	

The circuit for protecting the brake against overvoltage is integrated in the Motor Module and does not need to be installed externally.

Motor holding brake connection

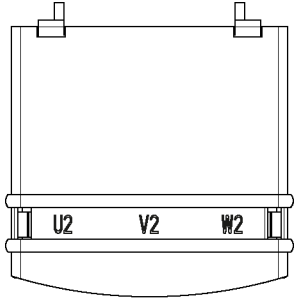
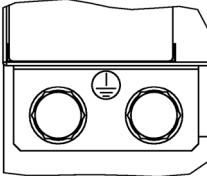
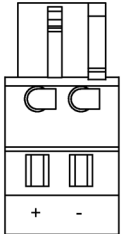
To ensure reliable opening of the motor holding brake, it requires a 24 V ± 10% voltage supply at the motor connection. It must be taken into account that voltage dips can occur along the supply cable.

- Use a Control Supply Module or a regulated DC power supply, whose setpoint is set to 26 V.
- Use supply cables with a minimum cross-section of 1.5 mm² (AWG 16) and a maximum length of 100 m.

Note

Protective circuit against overvoltage

The Motor Modules have an integrated overvoltage protection circuit for the motor holding brake. External protective circuits are not required.

 **WARNING**

High contact voltage on brake cables

For motor cables with integrated brake cable, when the motor is operated, the motor can charge the brake cable up to hazardous voltage levels. Coming into contact with the conductors or the shield of the brake cable can result in death or serious injury.

- Use motor cables with separate, shielded brake cables and connect the shield of the brake cable at both ends.

NOTICE

Premature wear of the motor holding brake when operated outside its permissible voltage range

Operating the motor holding brake outside its permissible voltage range at the motor connection will damage the brake.

- Ensure that the motor holding brake is only operated within its permissible voltage range.

NOTICE

Faulty brake function due to inadmissible wear

Inadmissible wear means that the braking function can no longer be guaranteed.

- Comply with the predefined Emergency Stop characteristics.
- Avoid repeated brief acceleration of the motor against a holding brake that is still closed. Consider the operating times of the brakes and the relays in the drive control and enable.

Note

The motor brake must be connected via connector X11. It is not permitted to directly connect the cable BR- to the electronics ground M.

Note

The total length of the power cables (motor feeder cables and DC link cables) must not exceed the values listed in Chapter Combination options, Line Modules with line reactors and line filters (Page 120).

6.5.2.3 X21 EP terminal/temperature sensor

Table 6- 49 X21 EP terminal / temperature sensor

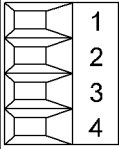
	Terminal	Function	Technical data
	1	+ Temp	Temperature sensors: KTY84–1C130 / PT1000 / PTC / bimetallic switch with NC contact
	2	- Temp	
	3	EP +24 V (pulse enable)	Supply voltage: 24 V DC (20.4 ... 28.8 V) Current consumption, typical: 4 mA at 24 V Isolated input The pulse inhibit function is only available when the "Safety Integrated Basic Functions via onboard terminals" software is enabled.
	4	EP M1 (enable pulses)	
Type: Screw terminal 1 (Page 708)			

EP terminals

The filter times to debounce terminals X21.3 and X21.4 can be parameterized (see SINAMICS S120/S150 List Manual). Additional parameter settings are also required in order to prevent discrepancy errors when performing bit pattern tests (light/dark tests). For comprehensive information, see the SINAMICS S120 Safety Integrated Function Manual, Section "Controlling the safety functions".

Note

Function of the EP terminals

The function of the EP terminals for pulse inhibit is only available if the "Safety Integrated Basic Functions via onboard terminals" software is enabled.

Temperature sensor connection

NOTICE

Damage to motor in the event of incorrectly connected KTY temperature sensor

A KTY temperature sensor connected with incorrect polarity cannot detect if the motor overheats. Overheating can cause damage to the motor.

- Connect the KTY temperature sensor with the correct polarity.

Note

The temperature sensor input is not needed if the motors feature an integrated DRIVE-CLiQ interface or if temperature values are detected by means of a different module (SMC, SME, TM).



! WARNING

Electric shock in the event of voltage flashovers at the temperature sensor

Voltage flashovers in the signal electronics can occur in motors without safe electrical separation of the temperature sensors.

- Use temperature sensors that comply with the specifications relating to protective separation.
- If safe electrical separation cannot be guaranteed (for linear motors or third-party motors, for example), use a Sensor Module External (SME120 or SME125) or Terminal Module TM120.

6.5.2.4 X200-X202 DRIVE-CLiQ interface

Table 6- 50 X200-X202: DRIVE-CLiQ interfaces

	Pin	Name	Technical data
	1	TXP	Transmit data +
	2	TXN	Transmit data -
	3	RXP	Receive data +
	4	Reserved, do not use	
	5	Reserved, do not use	
	6	RXN	Receive data -
	7	Reserved, do not use	
	8	Reserved, do not use	
	A	+ (24 V)	Power supply
	B	M (0 V)	Electronics ground

The blanking covers for the DRIVE-CLiQ interfaces are included in the scope of delivery.

Blanking cover (50 pcs.) Article number: 6SL3066-4CA00-0AA0

6.5.3 Connection example

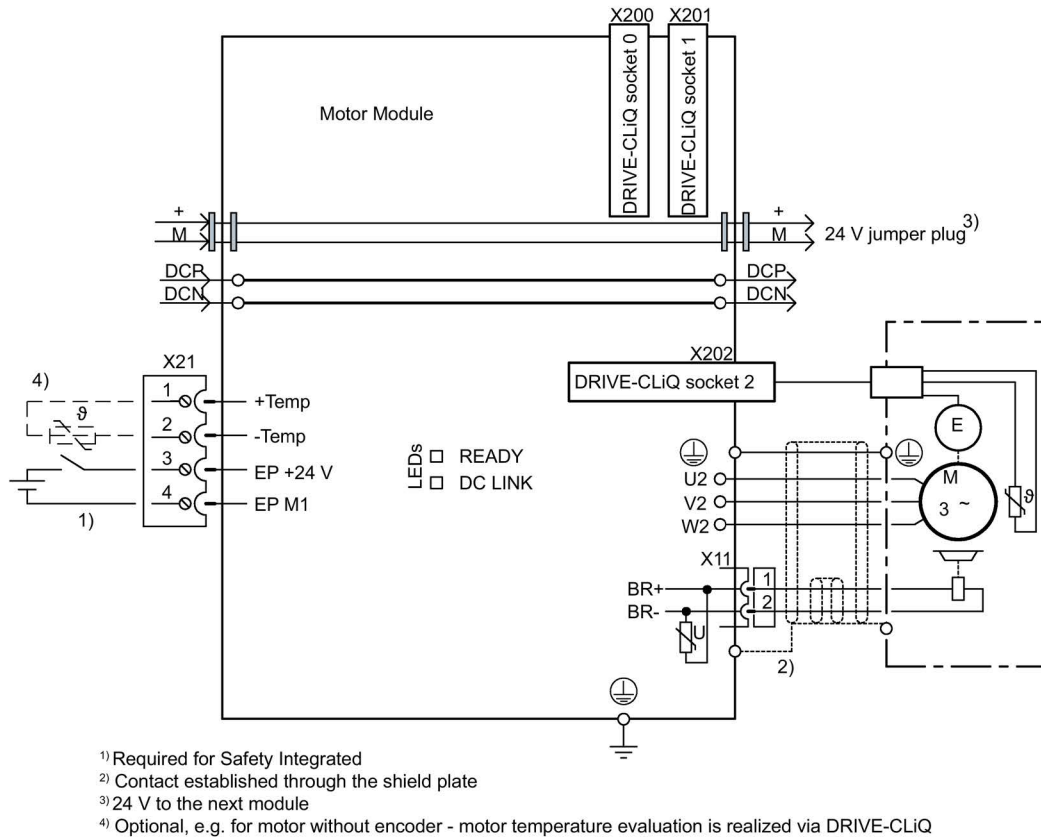

Figure 6-91 Connection example for Motor Module Liquid Cooled (200 A)

6.5.4 Meaning of LEDs

Table 6- 51 Meaning of LEDs

Status		Description, cause	Remedy
RDY	DC LINK		
Off	Off	The electronics power supply is missing or outside the permissible tolerance range.	–
Green	– ¹⁾	The component is ready for operation. Cyclic DRIVE-CLiQ communication is taking place.	–
	Orange	The component is ready for operation. Cyclic DRIVE-CLiQ communication is taking place. The DC link voltage is present.	–
	Red	The component is ready for operation. Cyclic DRIVE-CLiQ communication is taking place. The DC link voltage is outside the permissible tolerance range.	Check the line supply voltage.

Status		Description, cause	Remedy
RDY	DC LINK		
Orange	Orange	DRIVE-CLiQ communication is being established.	–
Red	-- ¹⁾	This component has at least one fault.	Resolve and acknowledge the fault.
Green/red (0.5 Hz)	-- ¹⁾	Firmware is being downloaded.	–
Green/red (2 Hz)	-- ¹⁾	Firmware download has been completed. The system waits for POWER ON.	Carry out a POWER ON.
Green/orange or Red/orange	-- ¹⁾	Recognition of components via LED is activated ²⁾ . Note: Both options depend on the LED status when activated.	–

1) Irrespective of the status of the LED "DC LINK"

2) For information about activating the parameter "Recognition via LED", see SINAMICS S120/S150 List Manual

6.5.5 Dimension drawing

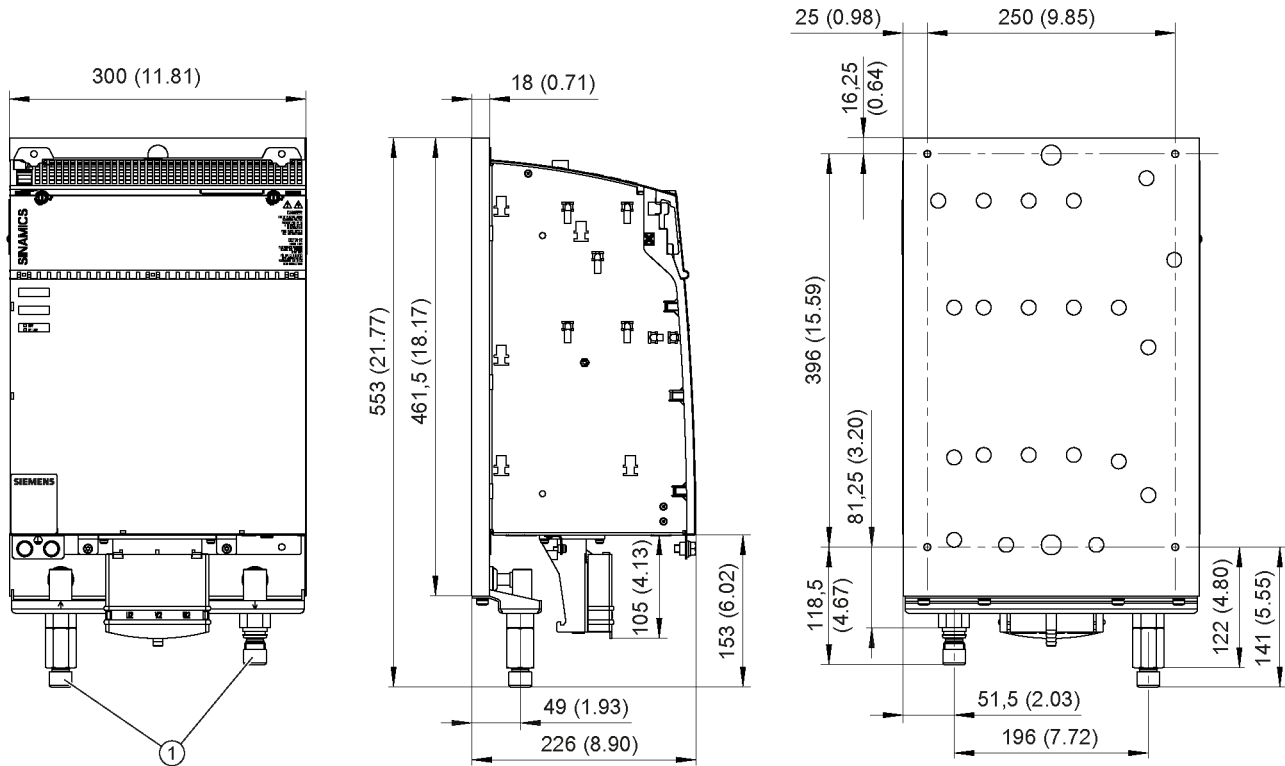

① Pipe thread ISO 228 G ½ B.

Figure 6-92 Dimension drawing of Motor Module Liquid Cooled (200 A), all dimensions in mm and (inches)

6.5.6 Installation

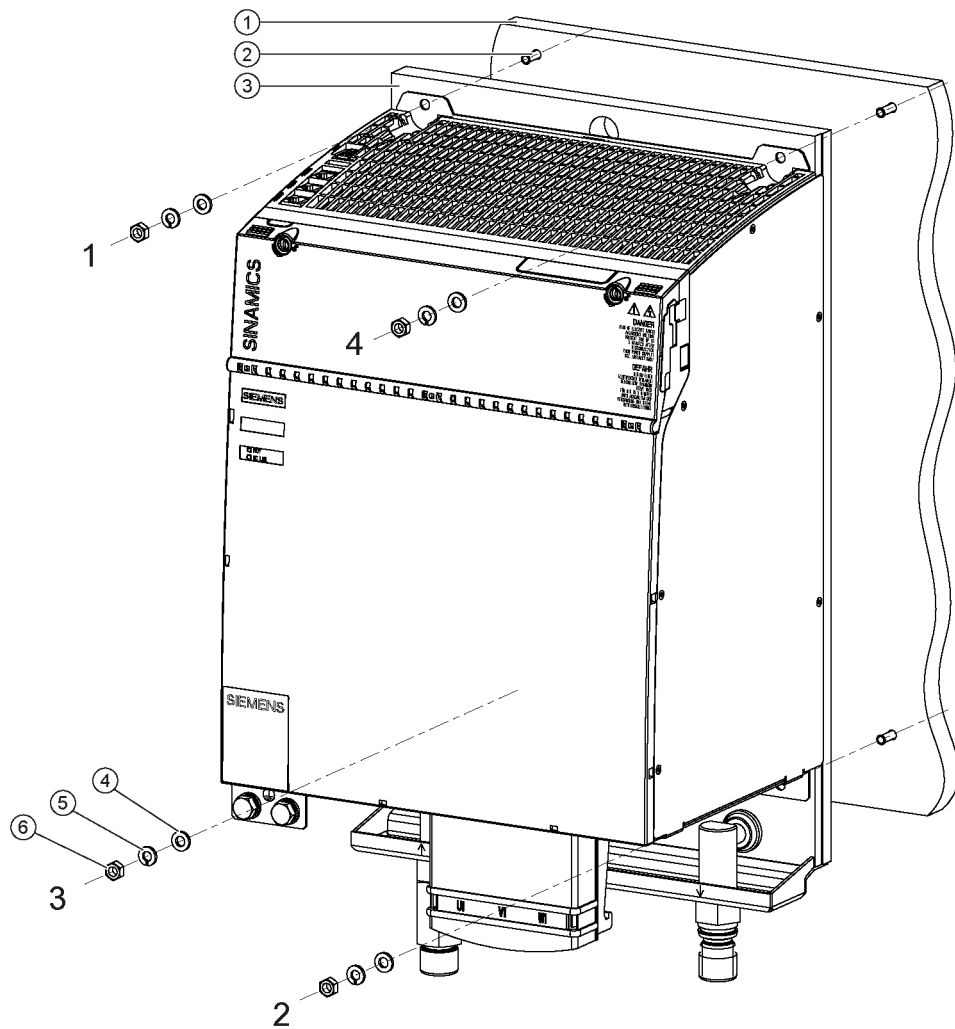

- ① Mounting surface
- ② Threaded bolts M6
- ③ Heat sink
- ④ Washer
- ⑤ Spring washer
- ⑥ M6 nut

Figure 6-93 Installing a Motor Module Liquid Cooled

Tightening torques:

1. Firstly, tighten the nuts by hand.
Tightening torque: 0.5 Nm (4.4 lbf in)
2. Then tighten the nuts in the specified sequence 1 to 4.
Tightening torque: 10 Nm (88.5 lbf in)

For installation, M6 threaded bolts and hexagon nuts/grub screws to ISO 7436-M6x40-14 H, property class 8.8 are recommended.

The coolant connections are located on the lower side of the components. All connection elements can be accessed using an appropriate tool.

- Thread type for coolant connections: Pipe thread ISO 228 G ½ B.

6.5.7 Technical data

Table 6- 52 Technical data for Motor Module Liquid Cooled 200 A

Liquid Cooled		6SL3125-1TE32-0AA.
Output current (at 600 V DC)		
Rated current (I _n)	A _{AC}	200
Base-load current (I _H)	A	141
Intermittent duty current (I _{s6}) 40%	A _{AC}	230
Peak current (I _{max})	A _{AC}	282
Output voltage	V _{AC}	0 ... 480
DC link current	A _{DC}	200
DC-link voltage (up to 2000 m above sea level)	V _{DC}	510 ... 720
DC link capacitance	µF	3995
Overvoltage trip	V _{DC}	820 ± 2 %
Undervoltage trip ¹⁾	V _{DC}	380 ± 2 %
Electronics power supply	V _{DC}	24 (20.4 ... 28.8)
Electronics current consumption at 24 V DC	A _{DC}	0.85
Current carrying capacity		
DC link busbars	A _{DC}	200
24 V DC busbars	A _{DC}	20
Unit rating²⁾		
Based on I _n (600 VDC; 4 kHz)	kW	107
Based on I _H	kW	76
Total power loss (including electronics losses, see Power loss tables (Page 734))	W	2070.4
Max. pulse frequency		
without derating	kHz	4
with derating	kHz	16
Output frequency	Hz	0 ... 550
Max. coolant temperature		
without derating	° C	45
with derating	° C	50
Max. permissible heat sink temperature	°C	79 (70% derating)
Rated flow rate for water at 70 kPa pressure drop (for other coolant (Page 749))	l/min	8
Volume of liquid internal	ml	100

Liquid Cooled		6SL3125-1TE32-0AA.
Ventilation clearances above/below in front of the component	mm mm	≥ 80 ≥ 50
Weight	kg	20.4

- 1) Default for 400 V line systems; undervoltage trip threshold is adjusted to the parameterized rated voltage
- 2) Rated power of a typical standard induction motor at 400 V 3 AC

6.5.7.1 Characteristics

Motor Modules Booksize Liquid Cooled

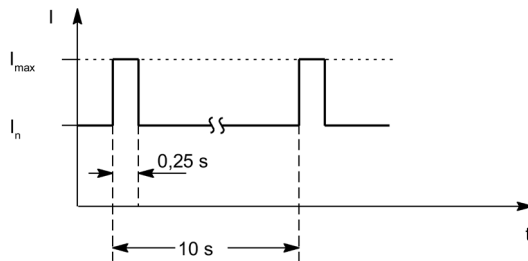

Figure 6-94 Duty cycle with initial load (for servo drives)

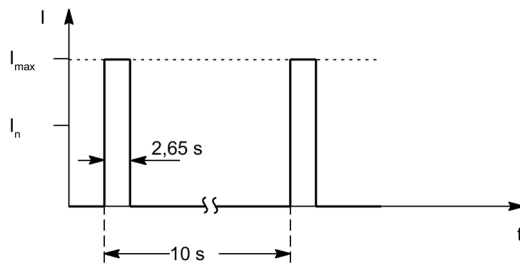

Figure 6-95 Duty cycle without initial load (for servo drives)

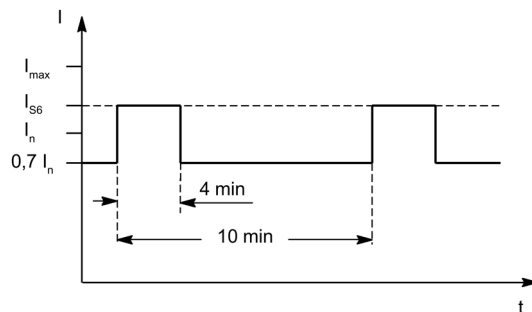

Figure 6-96 S6 duty cycle with initial load with a duty cycle duration of 600 s (for servo drives)

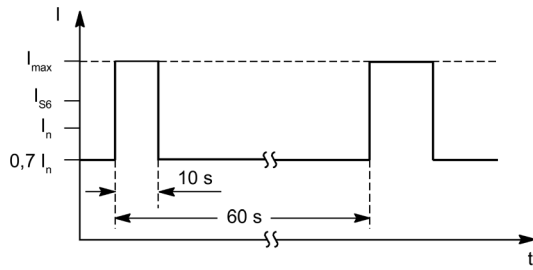

Figure 6-97 S6 duty cycle with initial load with a duty cycle duration of 60 s (for servo drives)

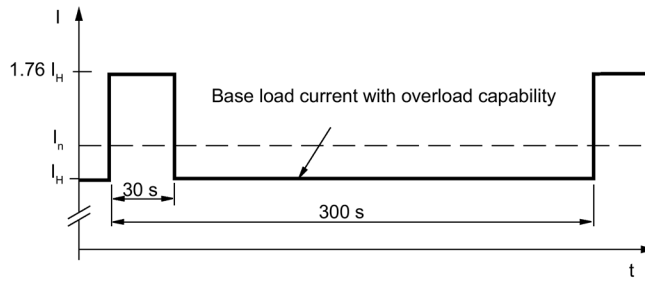

Figure 6-98 Duty cycle with 30 s overload for a duty cycle duration of 300 s

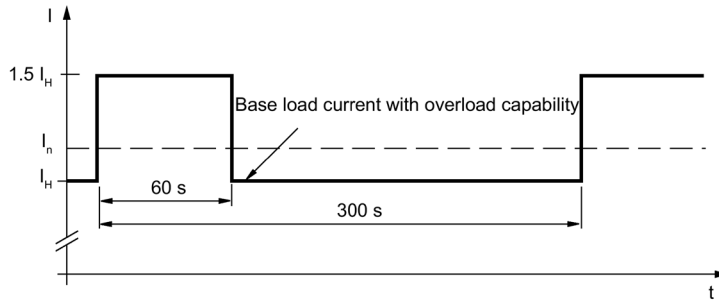

Figure 6-99 Duty cycle with 60 s overload for a duty cycle duration of 300 s

Derating characteristics for Motor Modules Booksize Liquid Cooled

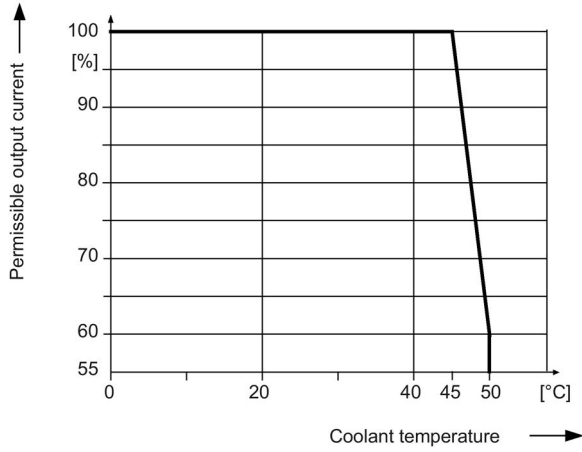

Figure 6-100 Output current as a function of the coolant temperature

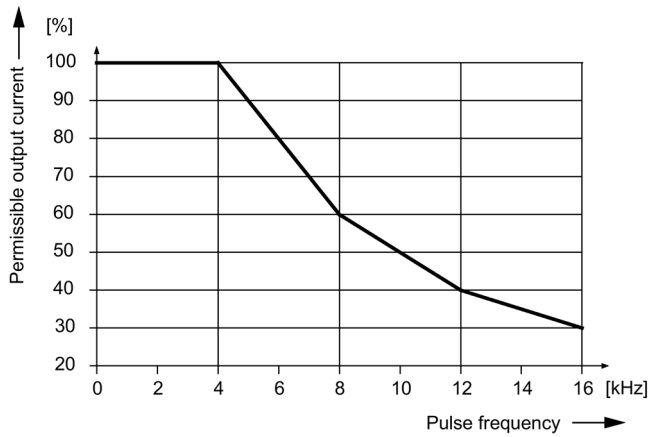

Figure 6-101 Output current as a function of the pulse frequency

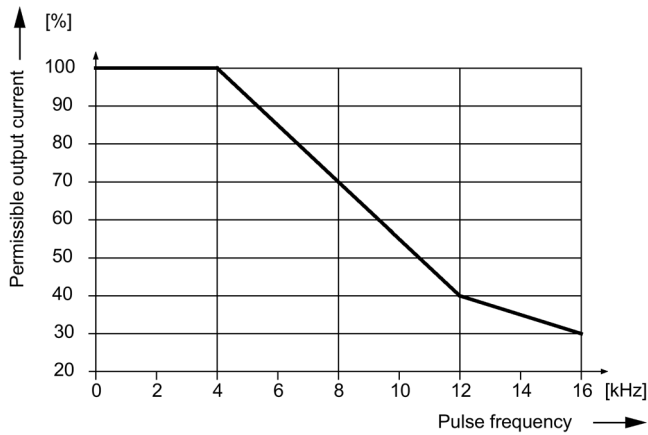

Figure 6-102 Output current as a function of the pulse frequency
(applies from Article number 6SL312.-1TE32-0AA4 and higher)

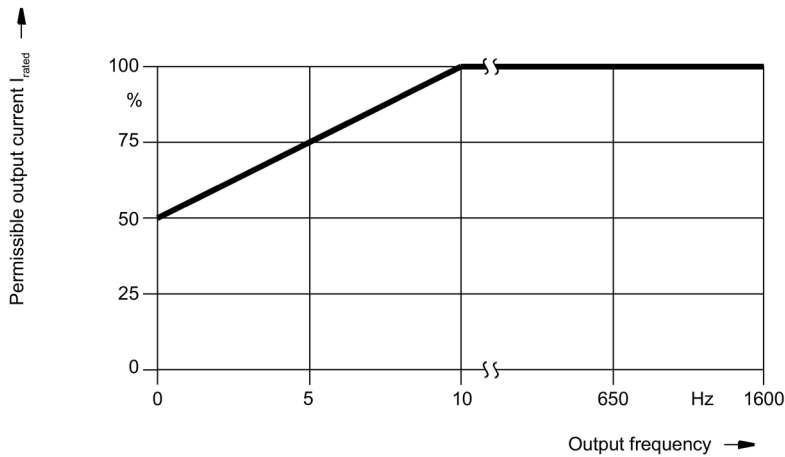

Figure 6-103 Output current at low frequencies

Dimensioning notes

- A current derating is only applicable for output frequencies < 10 Hz.
- Current derating should be taken into account if the percentage time of operation at frequencies < 10 Hz is more than 2 % of the daily total operating time.
- Also during load cycles, the current specified here must not be exceeded.
- When quickly passing through frequencies 0 to 10 Hz, derating does not have to be taken into account (e.g. for positioning applications).

Note

Information about derating the output current as a function of the ambient temperature and installation altitude is provided in Chapter "System data (Page 42)".

Motor Modules Booksize Compact

7.1 Description

A Motor Module Booksize Compact is a power unit (inverter) that provides the power supply for one motor or several motors. Power is supplied by the DC link of the drive unit. A Motor Module must be connected to a Control Unit via DRIVE-CLiQ. The open-loop and closed-loop control functions for the Motor Module are stored in the Control Unit.

1 motor can be connected to Single Motor Modules and 2 motors can be connected to Double Motor Modules.

Motor Modules Booksize Compact can be used either with cooling type "internal air cooling" or cooling type "cold plate". The cooling type is selected by parameter (see the SINAMICS S120/S150 List Manual).

7.2 Safety instructions for Motor Modules Booksize Compact



! WARNING

Electric shock due to the residual charge of the DC-link capacitors

Because of the DC link capacitors, a hazardous voltage is present for up to 5 minutes after the power supply has been switched off.

Contact with live parts can result in death or serious injury.

- Do not open the protective cover of the DC link until 5 minutes have elapsed.
- Measure the voltage before starting work on the DCP and DCN DC link terminals.



! WARNING

Electric shock when the protective cover of the DC link is open

Contact with live parts can result in death or serious injury.

- Only operate the components with closed protective cover.



! WARNING

Electric shock due to improper DC link connection

Incorrectly established connections can result in overheating and therefore fire with associated smoke. There is also a risk of an electric shock. This can result in serious injury or death.

- Only use adapters (DC link adapters and DC link rectifier adapters) released by Siemens for the connection to the DC link.



! WARNING

Electric shock due to incorrectly installed DC link bridges

Incorrectly installed DC link bridges **at the left-hand end of the drive line-up** can cause an electric shock.

- For all 50 mm wide modules¹⁾, remove the DC link bridge including the screws. Do not tighten the screws without the DC link bridges.
- For all components that are 75 mm wide or wider, the DC link bridges may neither be swung over to the left nor removed²⁾.

¹⁾ For 50 mm wide modules, the DC link bridge cannot be swung inwards.

²⁾ The DC link bridge guarantees the mechanical stability of the DC link busbars.



! WARNING

Electric shock due to missing DC-link side covers

Live parts are exposed if the DC link side covers are not fitted. Contact with these live parts could cause an electric shock.

- Mount the side covers on the first and last component in the drive line-up.
- Order any missing side covers (Article number: 6SL3162-5AA00-0AA0).



! WARNING

Electric shock due to incorrectly laid brake cables

If brake cables are laid without safe electrical separation, the insulation can fail and cause an electric shock.

Install the brake in one of the following ways:

- Connect the holding brake with the specified MOTION-CONNECT cable.
- Only use third-party cables with safe electrically separated brake cores or lay the brake cores with safe electrical separation.

⚠ WARNING**Fire as a result of overheated motor cables if cross-sections are smaller than the minimum permissible size**

Excessively thin motor cables can result in overheating. This can result in severe injury or death due to fire and smoke.

- Use cables that correspond to the Motor Module currents. Take into account the routing type, ambient temperature and cable length.
- If smaller cross-sections are selected, you must ensure the appropriate level of conductor protection in another way, e.g. by suitably setting the control parameters.

NOTICE**Device failure as a result of unshielded or incorrectly routed cables to temperature sensors**

Unshielded or incorrectly routed cables to temperature sensors can result in interference being coupled into the signal processing electronics from the power side. This can result in significant disturbance of all signals (fault messages) up to failure of individual components (destruction of the devices).

- Only use shielded cables as temperature sensor cables.
- If temperature sensor cables are routed together with the motor cable, use separately shielded cables twisted in pairs.
- Connect the cable shield to ground potential at both ends through a large surface area.
- Recommendation: Use suitable Motion Connect cables.

NOTICE**Premature wear of the motor holding brake when operated outside its permissible voltage range**

Operating the motor holding brake outside its permissible voltage range at the motor connection will damage the brake.

- Ensure that the motor holding brake is only operated within its permissible voltage range.

NOTICE**Damage through use of incorrect DRIVE-CLiQ cables**

Damage or malfunctions can occur on the devices or system when DRIVE-CLiQ cables are used that are either incorrect or have not been approved for this purpose.

- Only use suitable DRIVE-CLiQ cables that have been approved by Siemens for the particular application.

NOTICE

Motor damage due to the use of an unsuitable third-party motor

The motor insulation is subject to higher stresses when operated with a converter. Damage to the motor winding may occur as a result.

- Observe the notes in the System Manual "Requirements placed on third-party motors (<https://support.industry.siemens.com/cs/document/79690594>)".

Note

Malfunctions due to polluted DRIVE-CLiQ interfaces

Malfunctions can occur in the system through the use of polluted DRIVE-CLiQ interfaces.

- Cover unused DRIVE-CLiQ interfaces with the supplied blanking covers.
-

Notes for UL applications

Note

Motor overload protection

The Motor Module has integrated motor overload protection according to 61800-5-1. The protection threshold is 115 % of the full load current of the Motor Module. It can be adapted using parameter p5453 (see SINAMICS S120/S150 List Manual).

Note

The SINAMICS S120 Motor Modules Booksize Compact provide short-circuit protection at the motor output terminals.

Fault protection for the motor circuit

Note

The electronic overcurrent trip complies with the requirements laid down in IEC 60364-3-2:2005/AMD1 - Section 411 for protection against electric shock.

- Observe the installation specifications provided in this manual.
 - Observe the applicable installation standards.
 - Ensure the continuity of the protective conductor.
-

7.3 Interface description

7.3.1 Overview

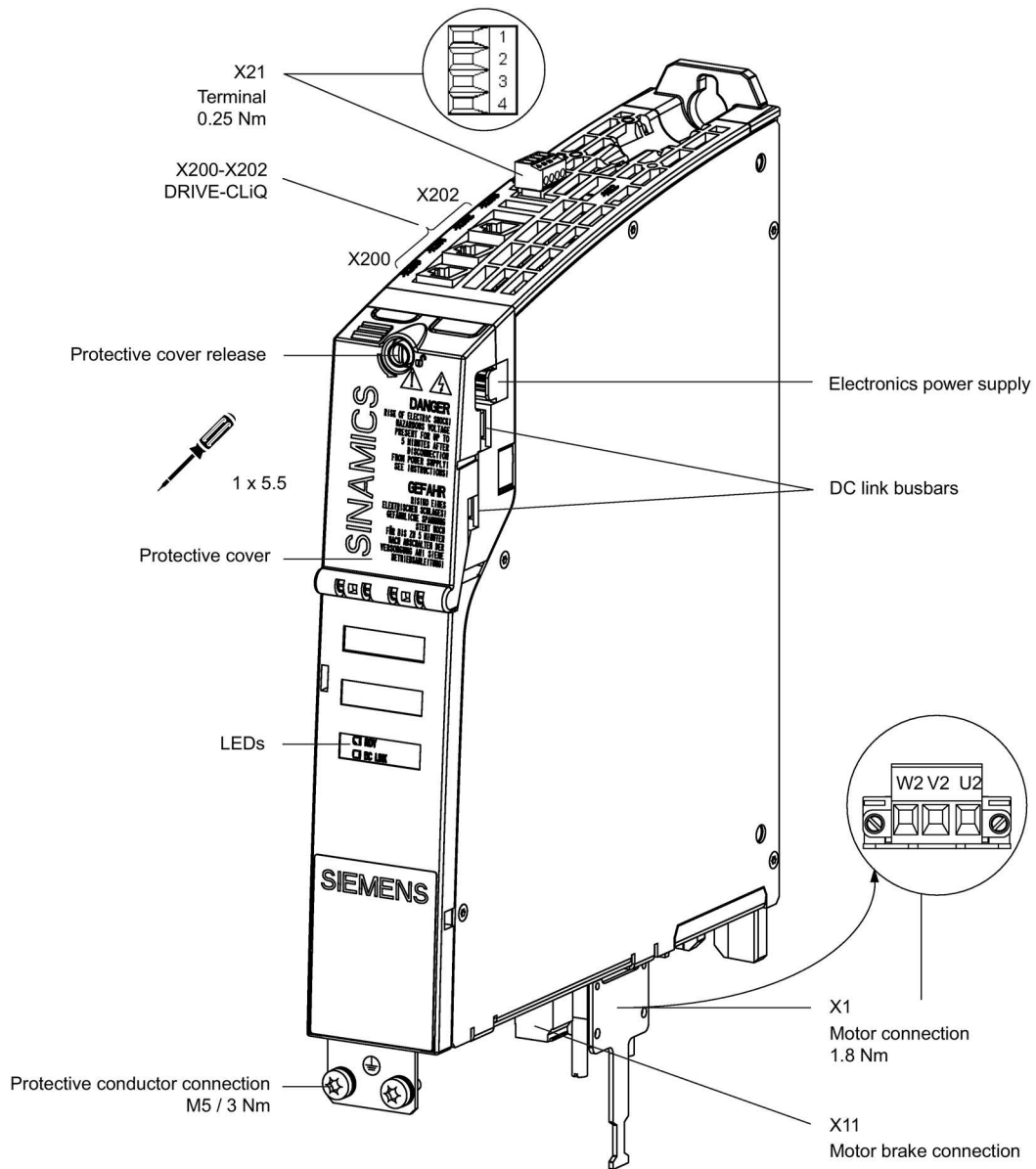

Figure 7-1 Interface overview, Single Motor Module Booksize Compact (example: 5 A)

7.3 Interface description

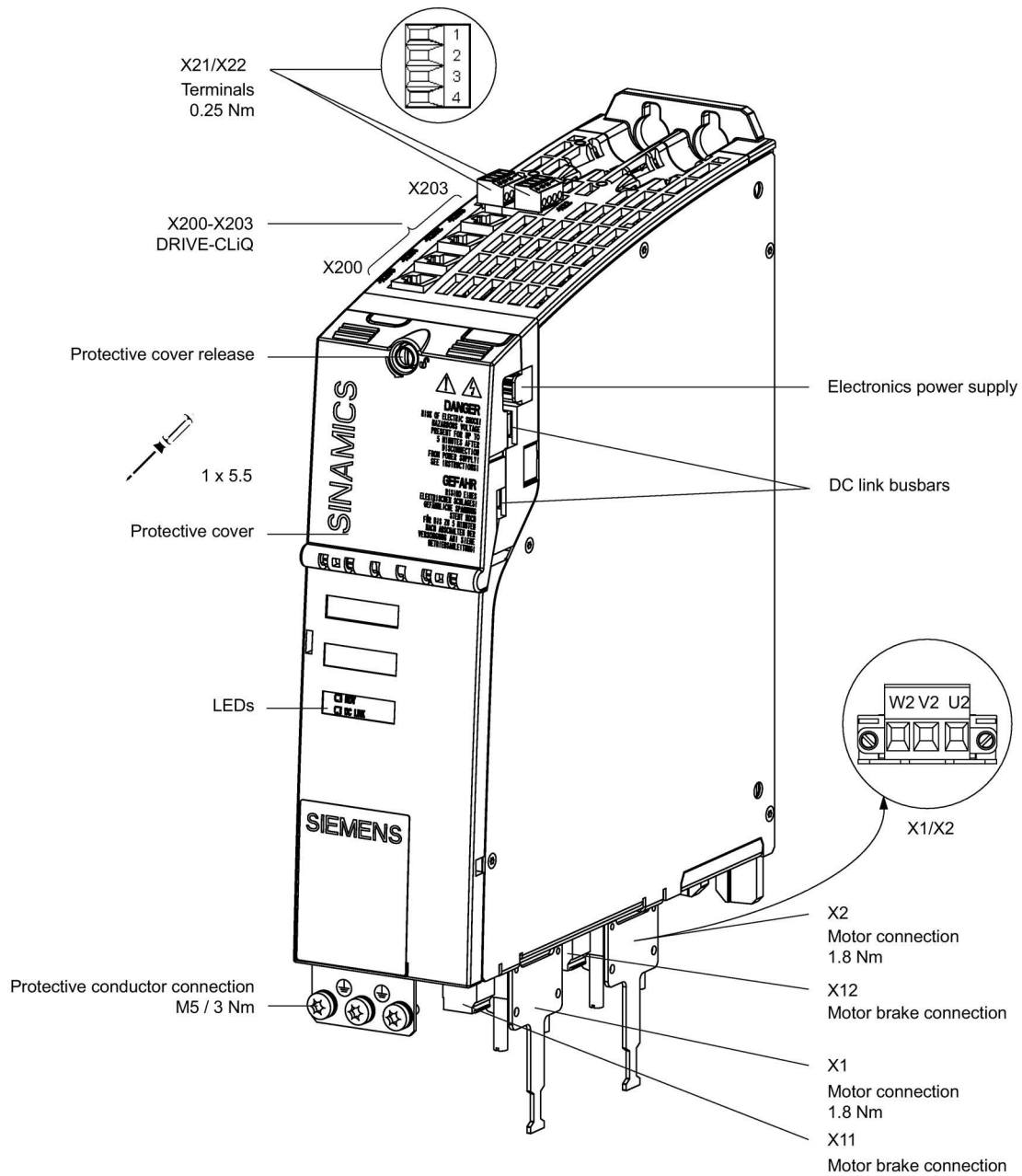
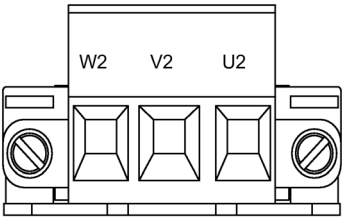
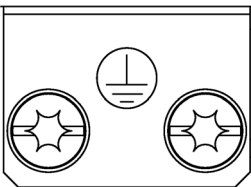
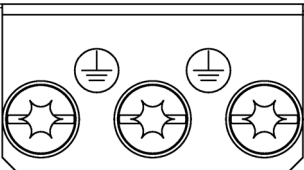

Figure 7-2 Interface overview, Double Motor Module Booksize Compact (example: 2 x 5 A)

7.3.2 X1/X2 motor connection

Table 7- 1 X1/X2 motor connection

	Terminal	Technical data
	U2	Type: Screw terminal 5 (Page 708)
	V2	
	W2	
	Protective conductor connection	Single Motor Modules 3 ... 18 A Threaded hole M5 / 3 Nm (26.6 lbf in) ¹⁾
		Double Motor Modules 2 x 1.7 ... 2 x 5 A Threaded hole M5 / 3 Nm (26.6 lbf in) ¹⁾
¹⁾ For ring cable lugs without insulation (Page 710)		

7.3.3 X11/X12 motor brake connection

Table 7- 2 X11/X12 motor brake connection

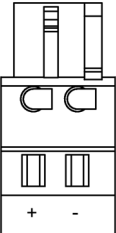
	Terminals	Technical data
	+ (BR+)	Brake connector ¹⁾ : Voltage 24 V DC Max. Load current 2 A Minimum load current 0.1 A Type: Spring-loaded terminal 2 (Page 708) Manufacturer: Wago; Article number: 721-102/026-000/56-000 The brake connector is part of the scope of delivery.
	- (BR-)	

¹⁾ The circuit for protecting the brake against overvoltage is integrated in the Motor Module and does not need to be installed externally.

Motor holding brake connection

To ensure reliable opening of the motor holding brake, it requires a $24\text{ V} \pm 10\%$ voltage supply at the motor connection. It must be taken into account that voltage dips can occur along the supply cable.

- Use a Control Supply Module or a regulated DC power supply, whose setpoint is set to 26 V.
- Use supply cables with a minimum cross-section of 1.5 mm^2 (AWG 16) and a maximum length of 100 m.

Note

Protective circuit against overvoltage

The Motor Modules have an integrated overvoltage protection circuit for the motor holding brake. External protective circuits are not required.

 WARNING
--

High contact voltage on brake cables

For motor cables with integrated brake cable, when the motor is operated, the motor can charge the brake cable up to hazardous voltage levels. Coming into contact with the conductors or the shield of the brake cable can result in death or serious injury.
--

- | |
|---|
| <ul style="list-style-type: none">• Use motor cables with separate, shielded brake cables and connect the shield of the brake cable at both ends. |
|---|

NOTICE

Premature wear of the motor holding brake when operated outside its permissible voltage range
--

Operating the motor holding brake outside its permissible voltage range at the motor connection will damage the brake.
--

- | |
|--|
| <ul style="list-style-type: none">• Ensure that the motor holding brake is only operated within its permissible voltage range. |
|--|

NOTICE

Faulty brake function due to inadmissible wear

Inadmissible wear means that the braking function can no longer be guaranteed.
--

- | |
|--|
| <ul style="list-style-type: none">• Comply with the predefined Emergency Stop characteristics.• Avoid repeated brief acceleration of the motor against a holding brake that is still closed. Consider the operating times of the brakes and the relays in the drive control and enable. |
|--|

Note

The motor brake must be connected via connector X11 and X12 on Double Motor Modules. It is not permitted to directly connect the cable BR- to the electronics ground M.

Note

The total length of the power cables (motor feeder cables and DC link cables) must not exceed the values listed in Chapter "Combination options, Line Modules with line reactors and line filters (Page 120)".

7.3.4 X21/X22 EP terminals/temperature sensor

Table 7- 3 X21/X22 EP terminals / temperature sensor

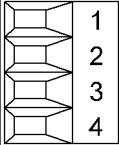
	Terminal	Function	Technical data
	1	+ Temp	Temperature sensors: KTY84–1C130 / PT1000 / PTC / bimetallic switch with NC contact
	2	- Temp	
	3	EP +24 V (pulse enable)	Supply voltage: 24 V DC (20.4 ... 28.8 V) Current consumption, typical: 4 mA at 24 V Isolated input The pulse inhibit function is only available when the "Safety Integrated Basic Functions via onboard terminals" software is enabled.
	4	EP M1 (enable pulses)	
Type: Screw terminal 1 (Page 708)			

EP terminals

Parameters p9651 and p9851 are used to set the filter times for debouncing terminals X21.3 and X21.4, as well as X22.3 and X22.4 (see SINAMICS S120/S150 List Manual). Additional parameter settings are also required in order to prevent discrepancy errors when performing bit pattern tests (light/dark tests). For comprehensive information, see the SINAMICS S120 Safety Integrated Function Manual, Section "Controlling the safety functions".

Note

Function of the EP terminals

The function of the EP terminals for pulse inhibit is only available if the "Safety Integrated Basic Functions via onboard terminals" software is enabled.

Temperature sensor connection

NOTICE

Damage to motor in the event of incorrectly connected KTY temperature sensor

A KTY temperature sensor connected with incorrect polarity cannot detect if the motor overheats. Overheating can cause damage to the motor.

- Connect the KTY temperature sensor with the correct polarity.

Note

The temperature sensor input is not needed if the motors feature an integrated DRIVE-CLiQ interface or if temperature values are detected by means of a different module (SMC, SME, TM).



! WARNING

Electric shock in the event of voltage flashovers at the temperature sensor

Voltage flashovers in the signal electronics can occur in motors without safe electrical separation of the temperature sensors.

- Use temperature sensors that comply with the specifications relating to protective separation.
- If safe electrical separation cannot be guaranteed (for linear motors or third-party motors, for example), use a Sensor Module External (SME120 or SME125) or Terminal Module TM120.

7.3.5 X200-X203 DRIVE-CLiQ interface

Table 7- 4 X200-X202: DRIVE-CLiQ interfaces for Single Motor Modules
X200-X203: DRIVE-CLiQ interfaces for Double Motor Modules

	Pin	Name	Technical data
	1	TXP	Transmit data +
	2	TXN	Transmit data -
	3	RXP	Receive data +
	4	Reserved, do not use	-
	5	Reserved, do not use	-
	6	RXN	Receive data -
	7	Reserved, do not use	-
	8	Reserved, do not use	-
	A	+ (24 V)	Power supply
	B	M (0 V)	Electronics ground

The blanking covers for the DRIVE-CLiQ interfaces are included in the scope of delivery.

Blanking cover (50 pcs.) Article number: 6SL3066-4CA00-0AA0

7.4 Connection example

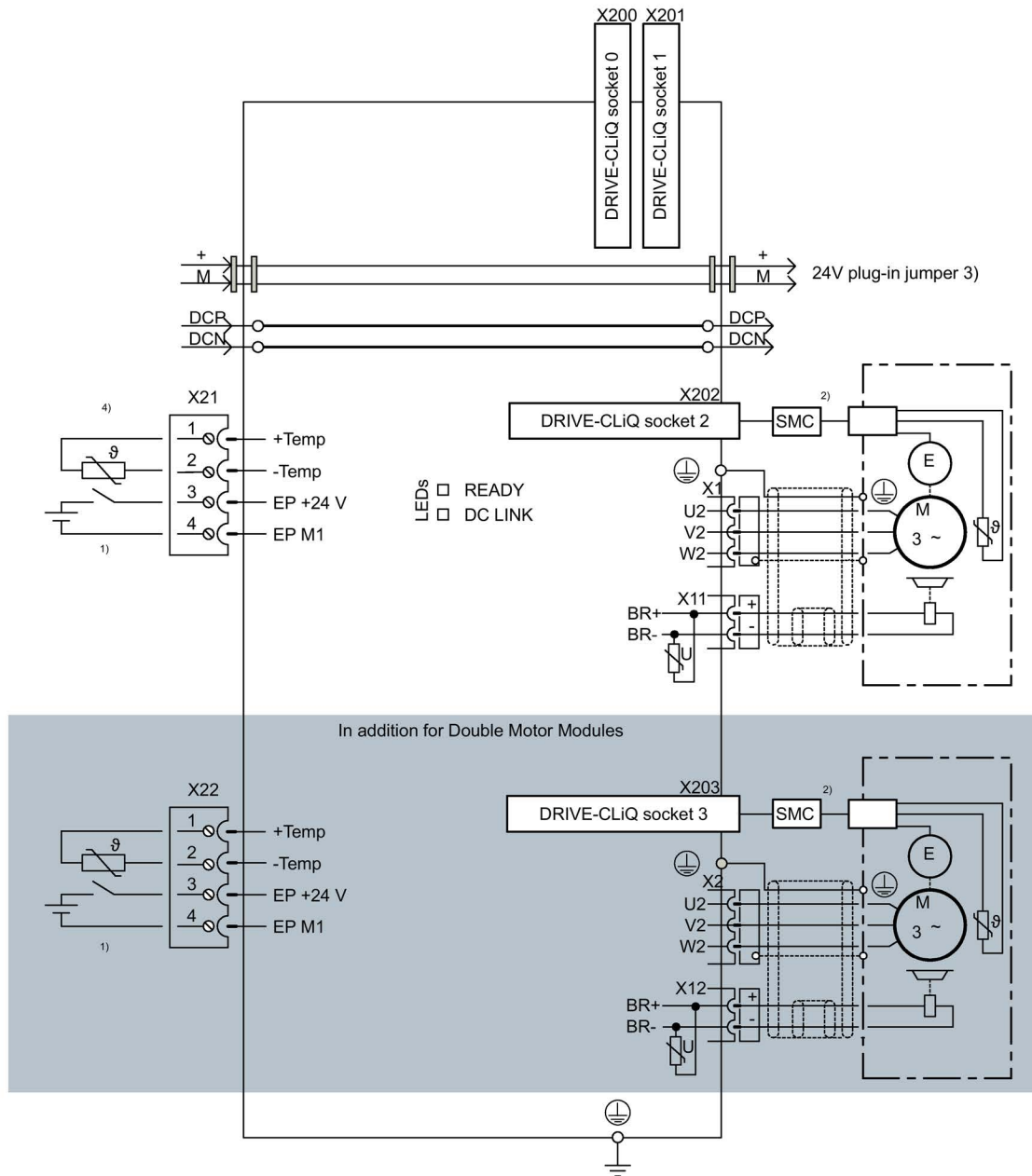

¹⁾ Required for safety

²⁾ SMC required for motors without DRIVE-CLiQ interface

³⁾ 24 V to the next module

⁴⁾ Alternative to evaluate the motor temperature

Figure 7-3 Connection example, Single Motor Modules Booksize Compact 3 A to 18 A and Double Motor Modules Booksize Compact 2 x 1.7 A to 2 x 5 A

7.5 Meaning of LEDs

Table 7- 5 Meaning of the LEDs on the Motor Module booksize compact

Status		Description, cause	Remedy
RDY	DC LINK		
Off	Off	The electronics power supply is missing or outside the permissible tolerance range.	–
Green	– ¹⁾	The component is ready for operation. Cyclic DRIVE-CLiQ communication is taking place.	–
	Orange	The component is ready for operation. Cyclic DRIVE-CLiQ communication is taking place. The DC link voltage is present.	–
	Red	The component is ready for operation. Cyclic DRIVE-CLiQ communication is taking place. The DC link voltage is outside the permissible tolerance range.	Check the line supply voltage.
Orange	Orange	DRIVE-CLiQ communication is being established.	–
Red	– ¹⁾	This component has at least one fault.	Resolve and acknowledge the fault.
Green/red (0.5 Hz)	– ¹⁾	Firmware is being downloaded.	–
Green/red (2 Hz)	– ¹⁾	Firmware download has been completed. The system waits for POWER ON.	Carry out a POWER ON.
Green/orange or red/orange	– ¹⁾	Component recognition via LED is activated ²⁾ . Comment: Both options depend on the LED status when component recognition is activated using the parameter.	–

1) Irrespective of the status of the LED "DC LINK"

2) For information about activating the parameter "Recognition via LED", see SINAMICS S120/S150 List Manual

7.6 Dimension drawings

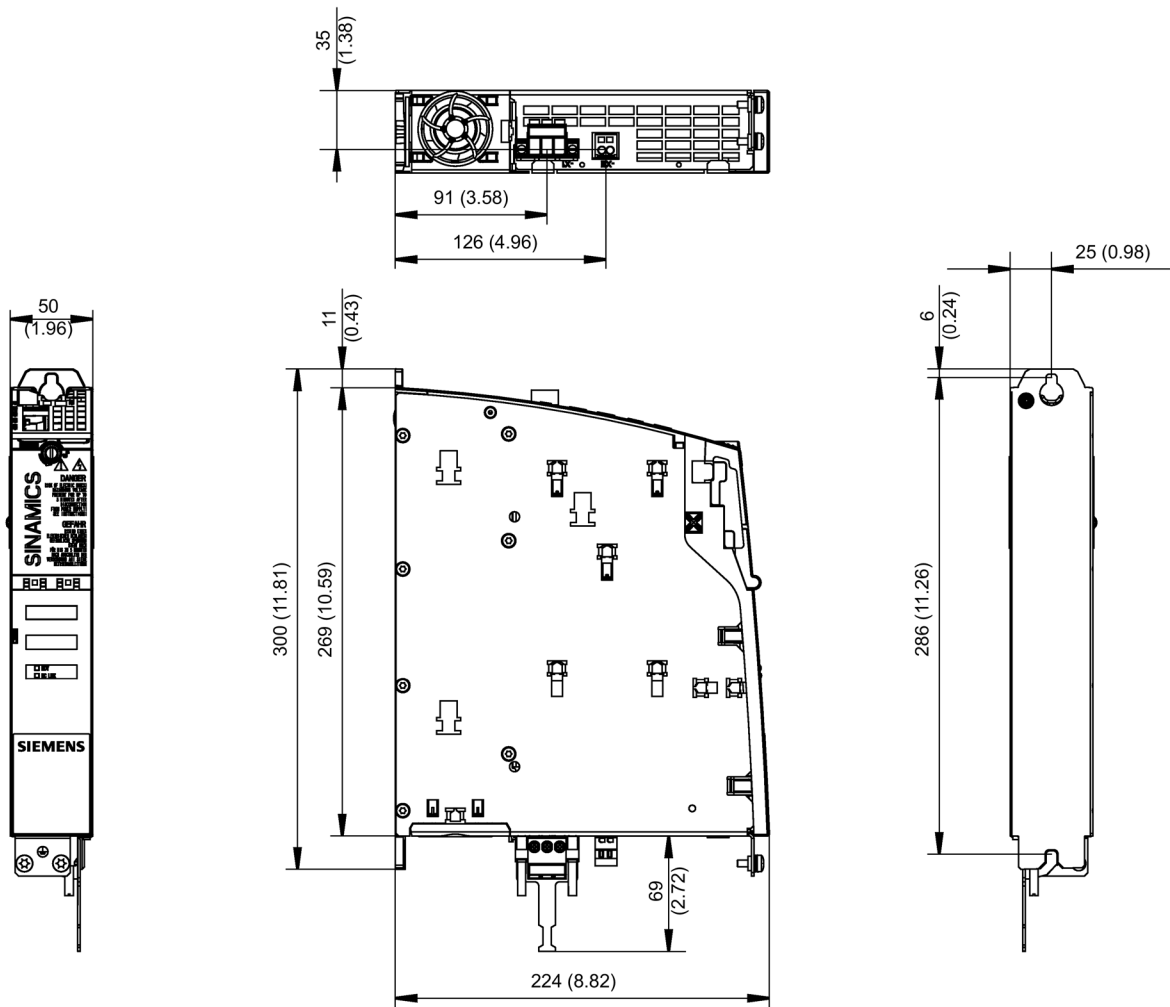

Figure 7-4 Dimension drawing of 3 A, 5 A, and 9 A Motor Modules Booksize Compact, all dimensions in mm and (inches); example: 5 A Single Motor Module

Table 7- 6 Motor Modules Booksize Compact 3 A, 5 A, and 9 A

Motor Module	Article No.
Single Motor Module 3 A	6SL3420-1TE13-0AA.
Single Motor Module 5 A	6SL3420-1TE15-0AA.
Single Motor Module 9 A	6SL3420-1TE21-0AA.

7.6 Dimension drawings

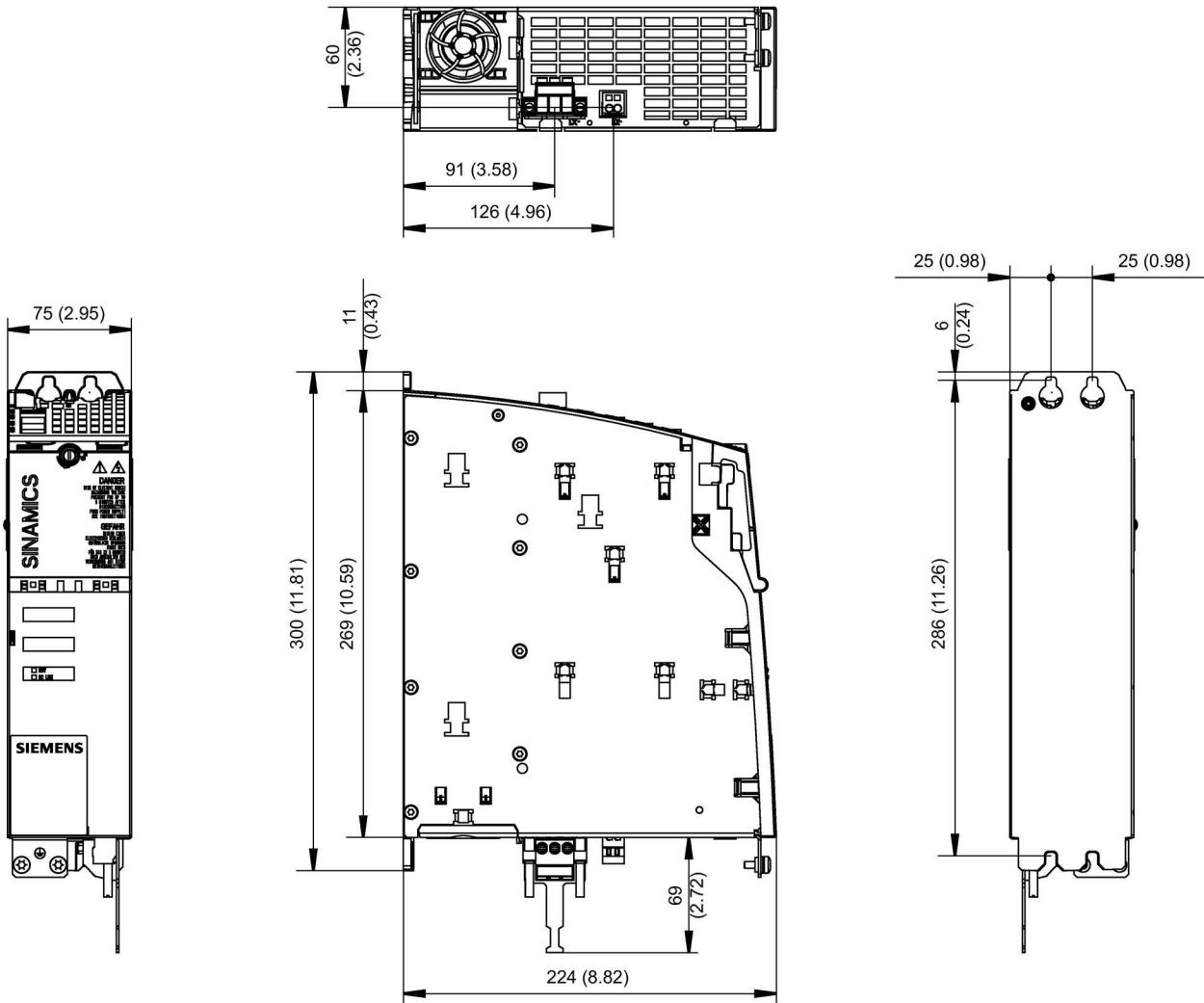

Figure 7-5 Dimension drawing of 18 A Motor Module Booksize Compact, all dimensions in mm and (inches)

Table 7-7 Motor Module Booksize Compact 18 A

Motor Module	Article No.
Single Motor Module 18 A	6SL3420-1TE21-8AA.

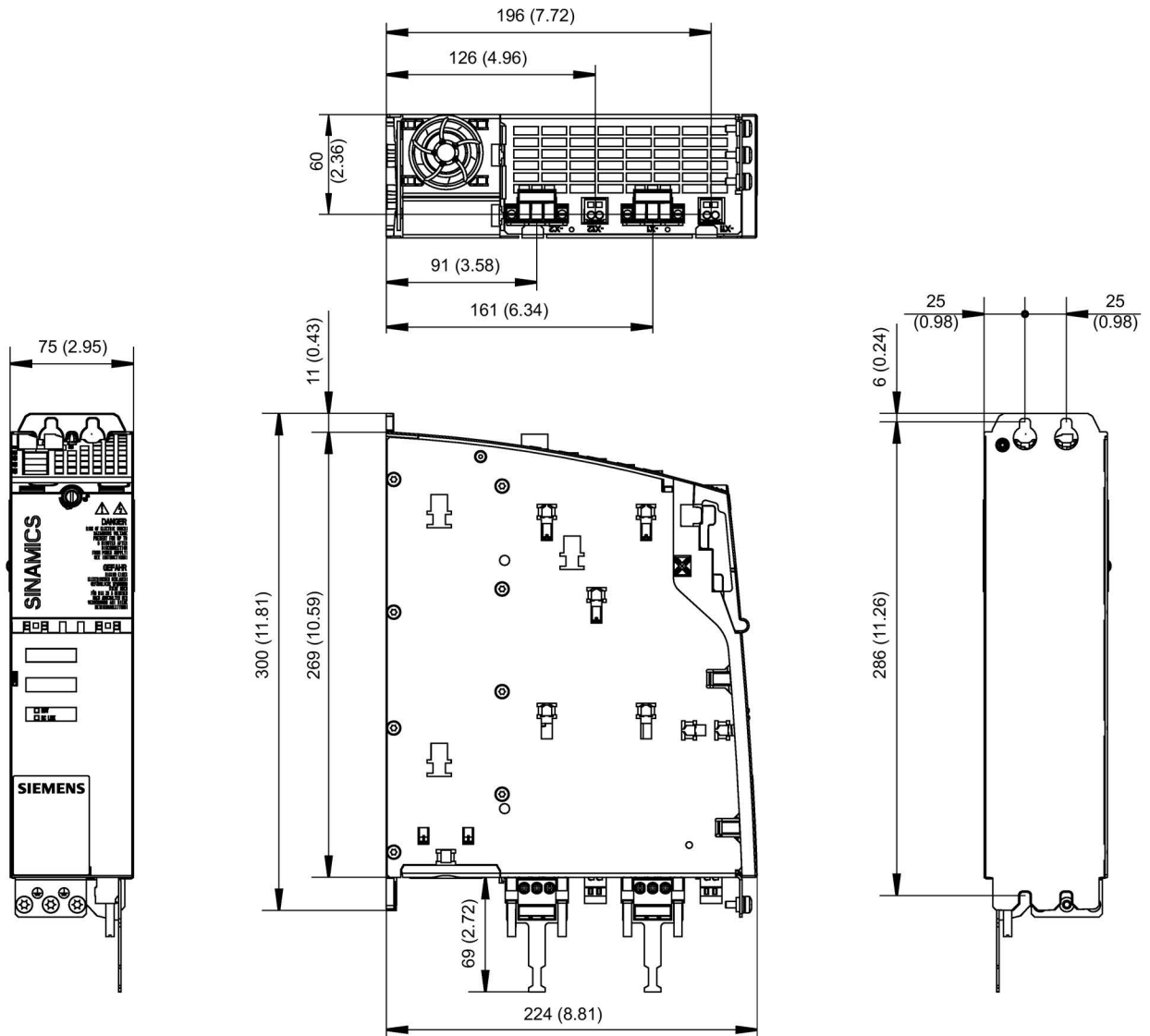

Figure 7-6 Dimension drawing of 2 x 1.7 A, 2 x 3 A, and 2 x 5 A Double Motor Modules Compact, all dimensions in mm and (inches); example: 2 x 5 A Double Motor Module

Table 7- 8 2 x 1.7 A, 2 x 3 A, and 2 x 5 A Double Motor Modules Booksize Compact

Double Motor Module	Article No.
2 x 1.7 A Double Motor Module	6SL3420-2TE11-7AA.
2 x 3 A Double Motor Module	6SL3420-2TE13-0AA.
2 x 5 A Double Motor Module	6SL3420-2TE15-0AA.

7.7 Mounting

Mounting a Motor Module Booksize Compact with internal air cooling

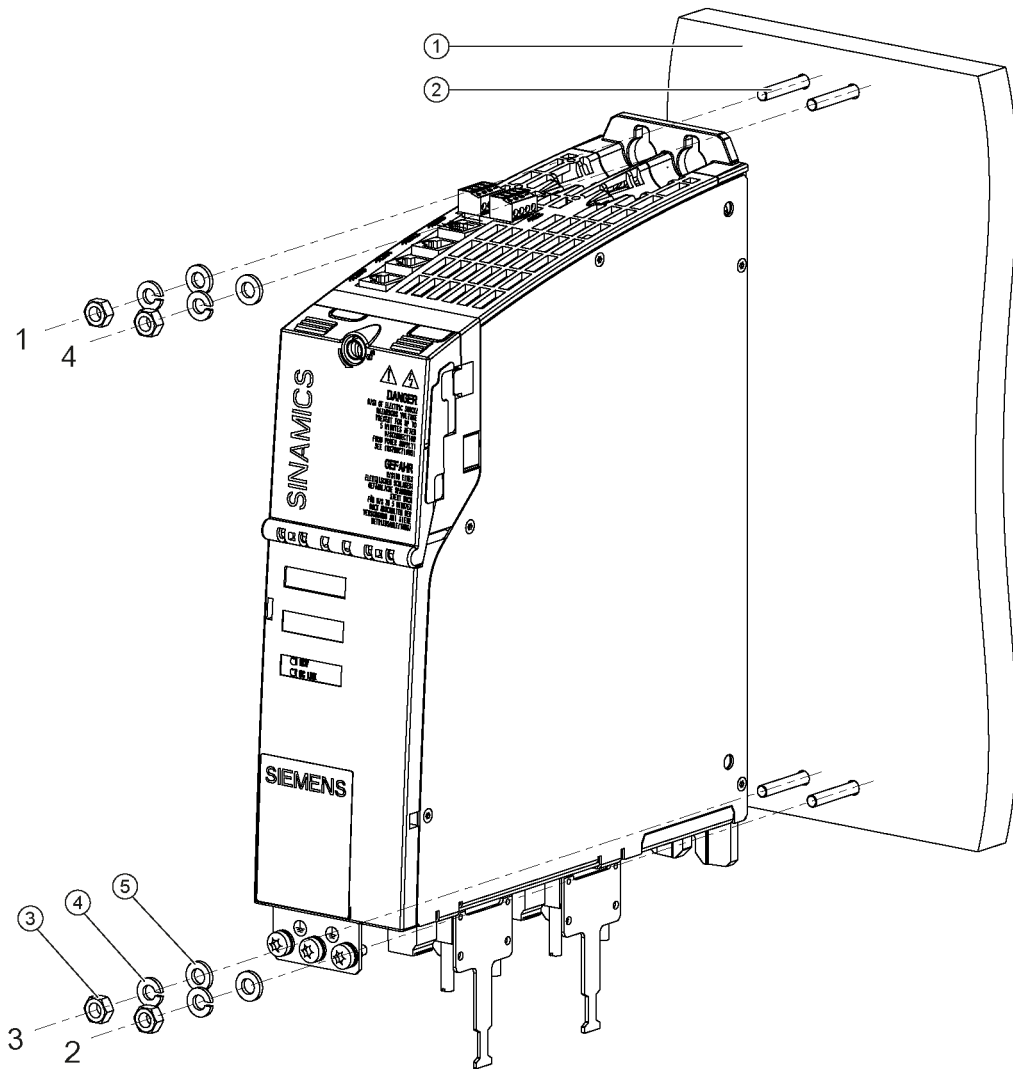

- ① Mounting wall
- ② Threaded bolts M6
- ③ M6 nut
- ④ Spring washer
- ⑤ Washer

Figure 7-7 Mounting a Motor Module Booksize Compact with internal air cooling

Tightening torques:

1. Firstly, only tighten the nuts by hand.
Tightening torque: 0.5 Nm (4.4 lbf in)
2. Then tighten the nuts in the specified sequence 1 to 4.
Tightening torque: 6 Nm (53.1 lbf in)

Mounting a Motor Module Booksize Compact on a cold plate

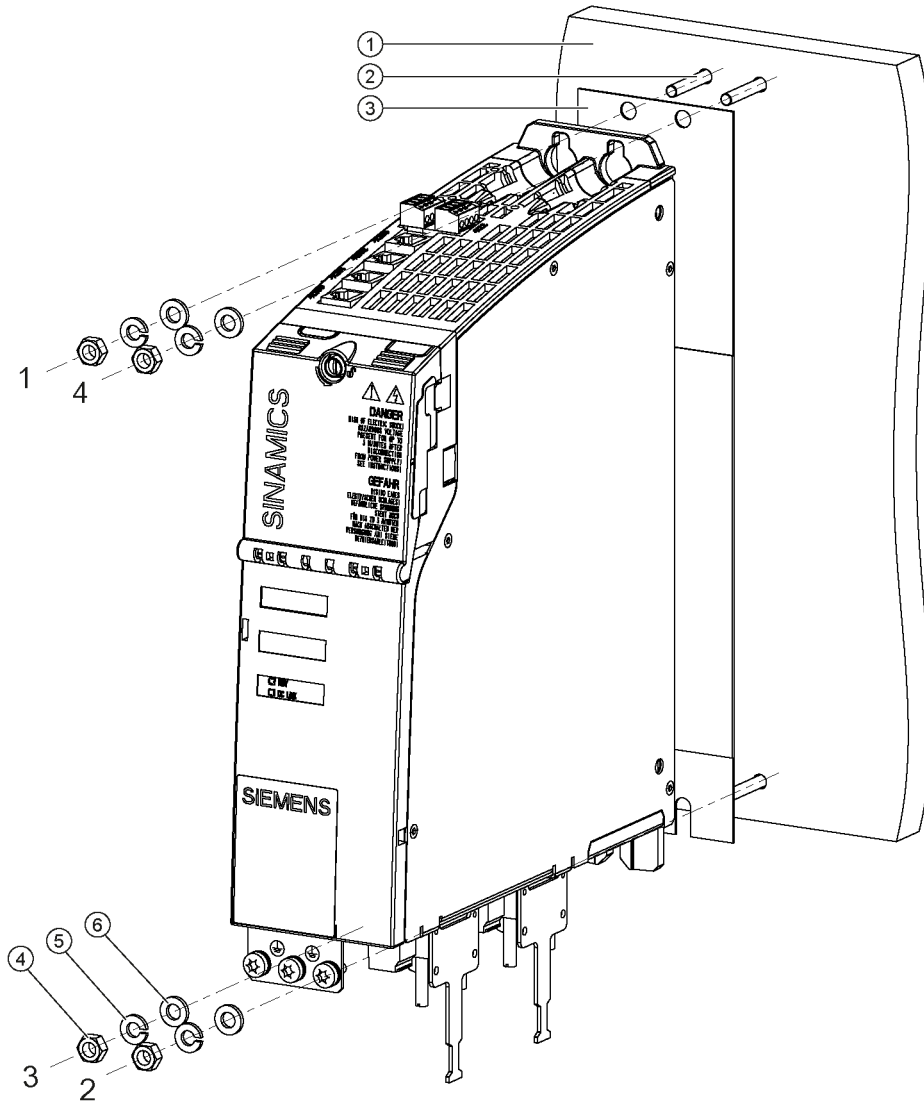

- ① Cold plate (air or liquid cooling)
- ② Threaded bolts M6
- ③ Heat-conducting foil
- ④ M6 nut
- ⑤ Spring washer
- ⑥ Washer

Figure 7-8 Mounting a Motor Module Booksize Compact on a cold plate

Tightening torques:

1. Firstly, only tighten the nuts by hand.
Tightening torque: 0.5 Nm (4.4 lbf in)
2. Then tighten the nuts in the specified sequence 1 to 4.
Tightening torque: 6 Nm (53.1 lbf in)

Special points to note in relation to mounting on a cold plate

To improve heat transfer, a heat-conducting medium must be used. Special spherical-indented heat-conducting foil must be used for this purpose. Every Motor Module Booksize Compact is supplied with heat-conducting foil cut to the right size. Note the mounting position of the heat-conducting foil.

Note

- Also replace the heat-conducting foil when replacing a component.
- Only use heat-conducting foil released or supplied by Siemens.

	Article No.
Heat-conducting foil, 50 mm	6SL3162-6FB01-0AA0
Heat-conducting foil, 75 mm	6SL3162-6FC01-0AA0

7.8 Technical data

7.8.1 Single Motor Modules

Table 7-9 Technical data Single Motor Modules Booksize Compact (3 A to 18 A)

Motor Modules Booksize Compact	6SL3420–	1TE13-0AA.	1TE15-0AA.	1TE21-0AA.	1TE21-8AA.
Output current (at 600 V DC)					
Rated current (I_N)	A_{AC}	3	5	9	18
Base-load current (I_H)	A	2.6	4.3	7.7	15.3
Intermittent duty current (I_{S6}) 40%	A_{AC}	3.5	6	10	24
Peak current (I_{max})	A_{AC}	9	15	27	54
Output voltage	V_{AC}	0 ... 0.717 x DC-link voltage			
DC link current	A_{DC}	3.6	6	11	22
DC-link voltage (up to 2000 m above sea level)	V_{DC}	510 ... 720			
DC link capacitance	μF	110	110	110	235
Overvoltage trip	V_{DC}	820 ± 2 %			
Undervoltage trip ¹⁾	V_{DC}	380 ± 2 %			
Electronics power supply	V_{DC}	24 (20.4 ... 28.8)			
Electronics current consumption at 24 V C					
For internal air cooling	A_{DC}	0.85	0.85	0.85	0.85
For cold plate cooling	A_{DC}	0.65	0.65	0.65	0.65
Current carrying capacity					
DC link busbars	A_{DC}	100	100	100	100
Reinforced DC link busbars	A_{DC}	150	150	150	150
24 V DC busbars	A_{DC}	20	20	20	20
Max. current motor brake	A	2	2	2	2

7.8 Technical data

Motor Modules Booksize Compact	6SL3420-	1TE13-0AA.	1TE15-0AA.	1TE21-0AA.	1TE21-8AA.
Unit rating²⁾ Based on I _n (600 VDC; 4 kHz) Based on I _H	kW kW	1.6 1.4	2.7 2.3	4.8 4.1	9.7 8.2
Total power loss (including electronics losses, see Power loss tables (Page 734)) Internal air cooling Cold plate int./ext.	W W	68 (8 kHz) 25.6/40	98 (8 kHz) 30.6/65	100.4 (4 kHz) 45.6/50	185.4 (4 kHz) 80.6/100
Max. pulse frequency without derating with derating	kHz kHz	8 16	8 16	4 16	4 16
Output frequency	Hz	0 ... 550			
Sound pressure level with internal air cooling	dB(A)	< 60	< 60	< 60	< 60
Cooling methods		Internal air cooling Cold plate cooling			
Cooling air requirement with internal air cooling	m ³ /h	29.6	29.6	29.6	29.6
Max. permissible heatsink temperature For internal air cooling For cold plate cooling	° C ° C	73 71	82 75	85 75	90 77
Ventilation clearances above/below	mm	≥ 80			
Weight	kg	2.7	2.7	2.7	3.4

- 1) Default setting for 400 V line supplies, undervoltage trip threshold can be reduced by up to 80 V and is adjusted to the parameterized line voltage
- 2) Rated power of a typical standard induction motor at 400 V 3 AC

7.8.2 Double Motor Modules

Table 7- 10 Technical data Double Motor Modules Booksize Compact (2 x 1.7 A to 2 x 5 A)

Double Motor Modules Booksize Compact	6SL3420-	2TE11-7AA.	2TE13-0AA.	2TE15-0AA.
Output current (at 600 V DC) Rated current (I _n) Base-load current (I _H) Intermittent duty current (I _{SB}) 40% Peak current (I _{max})	A _{AC} A A _{AC} A _{AC}	2 x 1.7 2 x 1.5 2 x 2 2 x 5.1	2 x 3 2 x 2.6 2 x 3.5 2 x 9	2 x 5 2 x 4.3 2 x 6 2 x 15
Output voltage	V _{AC}	0 ... 0.717 x DC-link voltage		
DC link current	A _{DC}	4.1	7.2	12
DC-link voltage (up to 2000 m above sea level)	V _{DC}	510 ... 720		
DC link capacitance	µF	165	165	165
Overvoltage trip Undervoltage trip ¹⁾	V _{DC} V _{DC}	820 ± 2 % 380 ± 2 %		
Electronics power supply	V _{DC}	24 (20.4 ... 28.8)		

Double Motor Modules Booksize Compact	6SL3420-	2TE11-7AA.	2TE13-0AA.	2TE15-0AA.
Electronics current consumption at 24 V C				
For internal air cooling	A _{DC}	1.15	1.15	1.15
For cold plate cooling	A _{DC}	0.9	0.9	0.9
Current carrying capacity				
DC link busbars	A	100	100	100
Reinforced DC link busbars	A	150	150	150
24 V DC busbars	A	20	20	20
Max. current motor brake	A	2 x 2	2 x 2	2 x 2
Unit rating²⁾				
Based on I _n (600 V, 8 kHz)	kW	2 x 0.9	2 x 1.6	2 x 2.7
Based on I _H	kW	2 x 0.8	2 x 1.4	2 x 2.3
Total power loss (including electronics losses, see Power loss tables (Page 734))				
Internal air cooling	W	114 (8 kHz)	134 (8 kHz)	194 (8 kHz)
Cold plate int./ext.	W	42/72	44/90	59/135
Max. pulse frequency				
without derating	kHz	8		
with derating	kHz	16		
Output frequency	Hz	0 ... 550		
Sound pressure level with internal air cooling	dB(A)	< 60	< 60	< 60
Cooling methods		Internal air cooling with mounted fan Cold plate cooling		
Cooling air requirement with internal air cooling	m ³ /h	29.6	29.6	29.6
Max. permissible heatsink temperature				
For internal air cooling	° C	84	88	93
For cold plate cooling	° C	71	75	75
Ventilation clearances				
above/below	mm	≥ 80		
Weight	kg	3.4	3.4	3.4

1) Default setting for 400 V line supplies, undervoltage trip threshold can be reduced by up to 80 V and is adjusted to the parameterized line voltage

2) Rated power of a typical standard induction motor at 400 V 3 AC

7.8.3 Characteristics

Rated duty cycles Motor Modules Booksize Compact

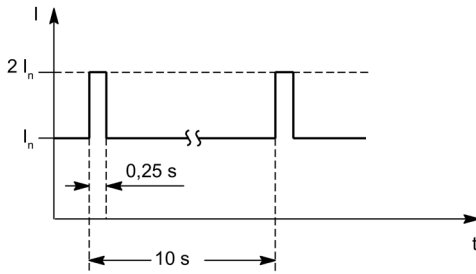

Figure 7-9 Duty cycle with initial load

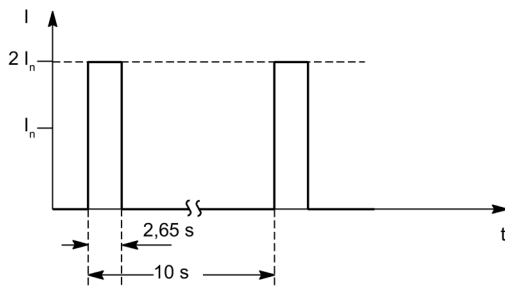

Figure 7-10 Duty cycle without initial load

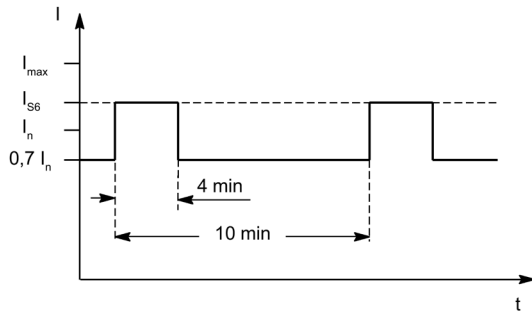

Figure 7-11 S6 duty cycle with initial load for a duty cycle duration of 600 s

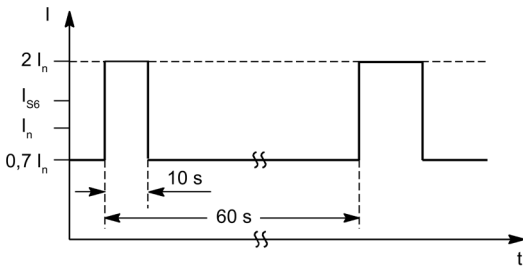

Figure 7-12 S6 duty cycle with initial load for a duty cycle duration of 60 s

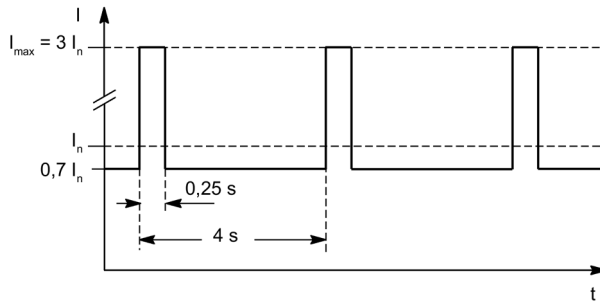

Figure 7-13 Peak current duty cycle with initial load

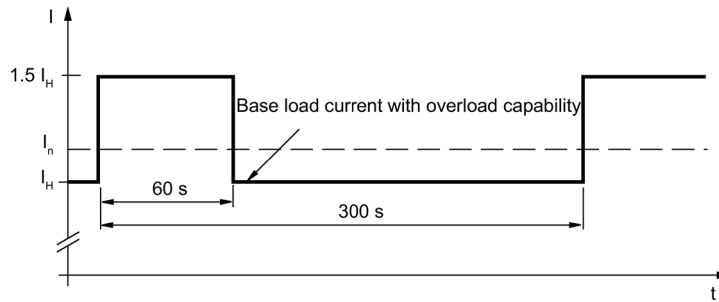

Figure 7-14 Duty cycle with 60 s overload for a duty cycle duration of 300 s

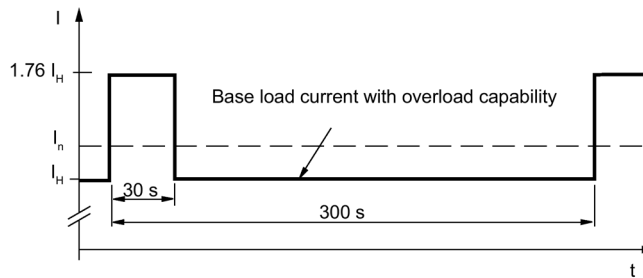

Figure 7-15 Duty cycle with 30 s overload for a duty cycle duration of 300 s

Derating characteristics for Motor Modules Booksize Compact

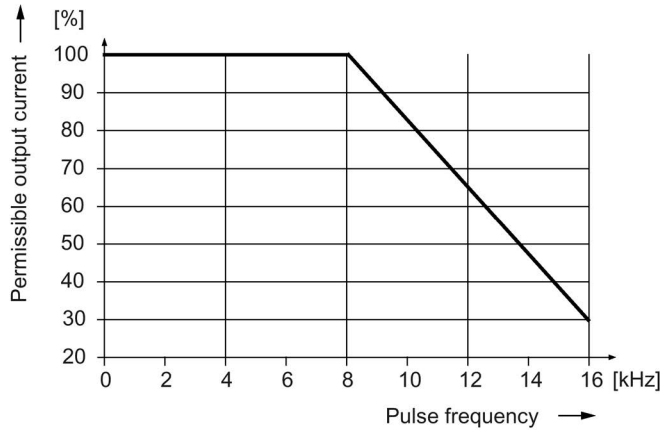

Figure 7-16 Output current as a function of the pulse frequency for the Motor Module ≤ 5 A

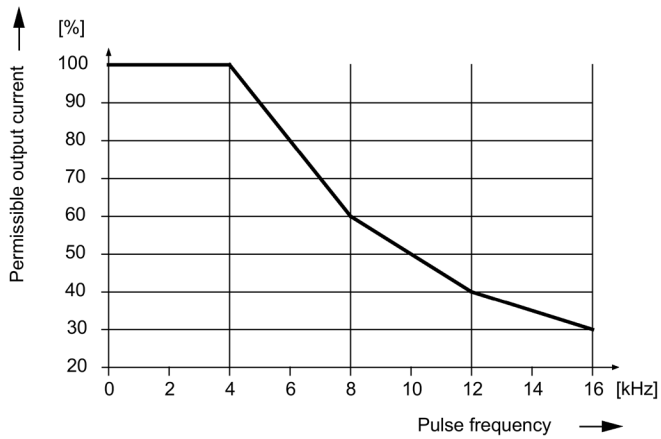

Figure 7-17 Output current as a function of the pulse frequency for the Motor Module ≥ 9 A

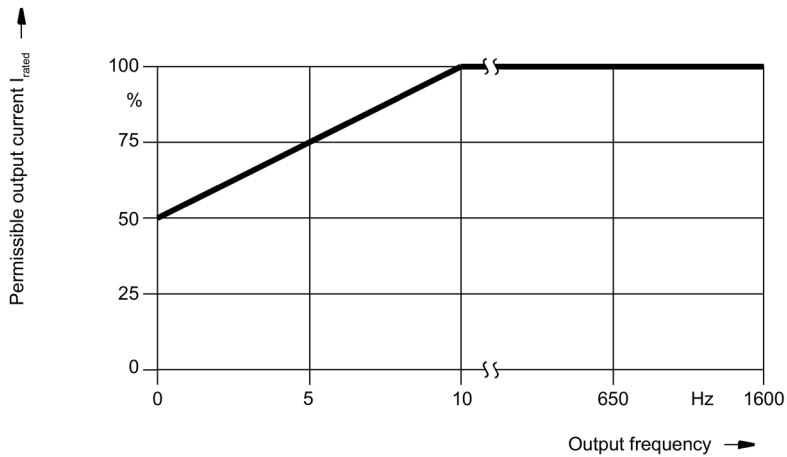

Figure 7-18 Output current at low frequencies

Dimensioning notes

- A current derating is only applicable for output frequencies < 10 Hz.
- Current derating should be taken into account if the percentage time of operation at frequencies < 10 Hz is more than 2 % of the daily total operating time.
- Also during load cycles, the current specified here must not be exceeded.
- When quickly passing through frequencies 0 to 10 Hz, derating does not have to be taken into account (e.g. for positioning applications).

Note

Information about derating the output current as a function of the ambient temperature and installation altitude is provided in Chapter "System data (Page 42)".

DC link components

8.1 Safety instructions for DC link components



! WARNING

Electric shock due to the residual charge of the DC-link capacitors

Because of the DC link capacitors, a hazardous voltage is present for up to 5 minutes after the power supply has been switched off.

Contact with live parts can result in death or serious injury.

- Do not open the protective cover of the DC link until 5 minutes have elapsed.
- Measure the voltage before starting work on the DCP and DCN DC link terminals.



! WARNING

Electric shock when the protective cover of the DC link is open

Contact with live parts can result in death or serious injury.

- Only operate the components with closed protective cover.



! WARNING

Electric shock due to improper DC link connection

Incorrect connections can cause overheating and so fire and smoke development. There is also a risk of an electric shock. This can result in serious injury or death.

- Only use adapters (DC link adapters and DC link rectifier adapters) released by Siemens for the connection to the DC link.



⚠ WARNING
Electric shock due to incorrectly installed DC link bridges
Incorrectly installed DC link bridges at the left-hand end of the drive line-up can cause an electric shock.
<ul style="list-style-type: none">• For all 50 mm wide modules¹⁾, remove the DC link bridge including the screws. Do not tighten the screws without the DC link bridges.• For all components that are 75 mm wide or wider, the DC link bridges may neither be swung over to the left nor removed²⁾.
<p>¹⁾ For 50 mm wide modules, the DC link bridge cannot be swung inwards. ²⁾ The DC link bridge guarantees the mechanical stability of the DC link busbars.</p>



⚠ WARNING
Electric shock due to missing DC-link side covers
Live parts are exposed if the DC link side covers are not fitted. Contact with these live parts could cause an electric shock.
<ul style="list-style-type: none">• Mount the side covers on the first and last component in the drive line-up.• Order any missing side covers (Article number: 6SL3162-5AA00-0AA0).



⚠ WARNING
High leakage currents when the protective conductor in the line feeder cable is interrupted
The drive components conduct a high leakage current via the protective conductor. Touching conductive parts when the protective conductor is interrupted can result in death or serious injury.
<ul style="list-style-type: none">• Carefully comply with the applicable regulations for dimensioning the protective conductor (see Chapter "Protective connection and equipotential bonding (Page 714)").

NOTICE
Damage through use of incorrect DRIVE-CLiQ cables
Damage or malfunctions can occur on the devices or system when DRIVE-CLiQ cables are used that are either incorrect or have not been approved for this purpose.
<ul style="list-style-type: none">• Only use suitable DRIVE-CLiQ cables that have been approved by Siemens for the particular application.

Note

Malfunctions due to polluted DRIVE-CLiQ interfaces

Malfunctions can occur in the system through the use of polluted DRIVE-CLiQ interfaces.

- Cover unused DRIVE-CLiQ interfaces with the supplied blanking covers.
-

8.2 Braking Module Booksize

8.2.1 Description

The Braking Module Booksize is always used together with an external braking resistor. It has the following tasks:

- Controlled stop of the drives in the event of a power failure (e.g. emergency retraction or EMERGENCY OFF Category 1)
- Limiting of DC-link voltage for brief periods of generator operation (e.g. if the regenerative feedback capability of the Line Module is deactivated, not adequately dimensioned, or restricted due to brief line interruption)

The Braking Module includes the necessary power electronics and control. When the Braking Module is in operation, the power which is fed back into the DC link is dissipated via an external braking resistor.

External braking resistors

Braking resistors without thermostatic switch 6SN1113-1AA00-0DA0 ($P_N = 0.3$ kW) and 6SL3100-1BE31-0AA0 ($P_N = 1.5$ kW) can be operated at the Braking Module Booksize. The cable lengths between the Braking Module and braking resistor is limited to a maximum of 10 m.

The scope of delivery of the braking resistor 6SN1113-1AA00-0DA0 includes a shielded connection cable (3 m, 3 x 1.5 mm²).

Rapid discharge

Furthermore, the Braking Module Booksize can be used with a braking resistor to quickly discharge the DC link capacitors. The DC link is discharged in a controlled manner via the braking resistor once the infeed unit has been switched off and the line-up has been disconnected from the line supply (e.g. via the main switch or line contactor). The function can be activated via a digital input on the Braking Module. A quick discharge makes sense, for example, when maintenance tasks are to be performed at the Motor Module and/or motor installation (reduction of the discharge time).



⚠ WARNING
Electric shock when live parts are touched after a rapid discharge
On completion of quick discharge, a voltage of 30 V is still present at the DC link. If the fast discharge is interrupted before it has been completed, then this voltage can be more than 60 V. Touching live components can result in death or severe injury.
<ul style="list-style-type: none">• Check the DC link to ensure that it is in a no voltage state before starting any work.

NOTICE
Damage to equipment or motors in the event of rapid discharge
For a fast discharge, the Motor Module or the connected motors can be damaged.
<ul style="list-style-type: none">• Ensure that all permanently excited induction motors are at a complete standstill, and that the drive system is completely disconnected from the supply system before activating the rapid discharge.

Monitoring functions

- Automatic detection of braking resistors and braking power monitoring
- I²t monitoring of the braking resistors.
- Temperature monitoring of the Braking Module
- Short circuit and overload detection
- Ground fault detection

8.2.2 Safety instructions for Braking Modules Booksize

NOTICE
Device failure as a result of unshielded or incorrectly routed cables to braking resistors
Unshielded or incorrectly routed cables to braking resistors can result in interference being coupled into the signal processing electronics from the power side. This can result in significant disturbance of all signals (fault messages) up to failure of individual components (destruction of the devices).
<ul style="list-style-type: none">• Only use shielded cables for cables to braking resistors.

NOTICE

Danger to life through the use of non-approved braking resistors

Braking resistors can be damaged when using braking resistors other than those specified in this Manual.

- Only use braking resistors approved by Siemens.

8.2.3 Interface description

8.2.3.1 Overview

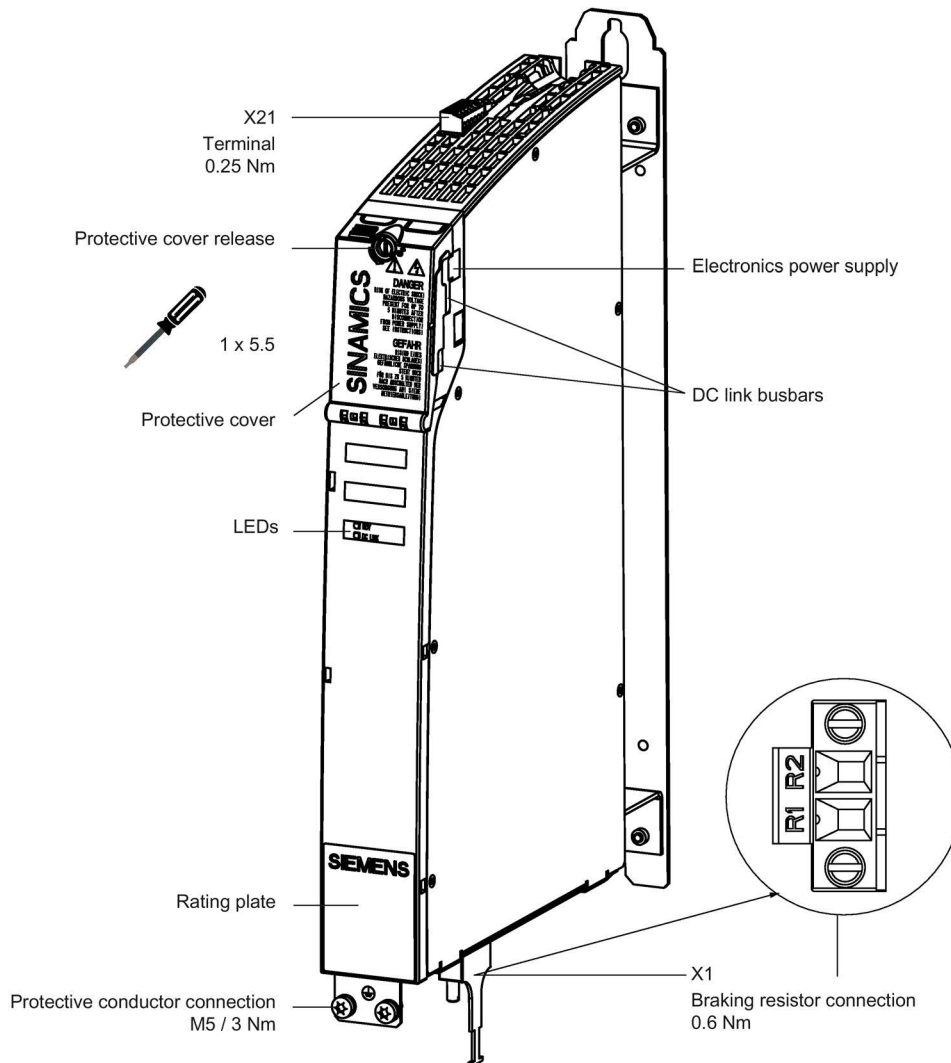

Figure 8-1 Interface overview, Braking Module Booksize

8.2.3.2 X1 braking resistor connection

Table 8- 1 X1 braking resistor connection

	Terminal	Designation	Technical data
	1	Braking resistor connection R1	Continuously short-circuit proof
	2	Braking resistor connection R2	
Type: Screw terminal 4 (Page 708)			

Table 8- 2 Braking resistors without a thermostatic switch for Braking Modules

Braking resistor	R in Ω	P _N in kW	P _{max} in kW
6SN1113-1AA00-0DA0	17	0.3	25
6SL3100-1BE31-0AA0	5.7	1.5	100

For detailed technical information on the braking resistors, see the section entitled Braking resistors (Page 529).

8.2.3.3 X21 digital inputs/outputs

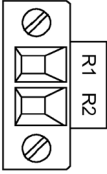
Table 8- 3 X21 digital inputs/outputs

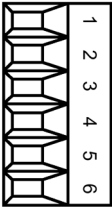
	Terminal	Designation ¹⁾	Technical data
	1	DI low: Enable Braking Module DI high: Inhibit/acknowledgement Edge change, high → low: fault acknowledgement	Voltage: -3 ... +30 V Typical current drain: 10 mA at 24 V DC Level (incl. ripple) High level: 15 ... 30 V Low level: -3 ... +5 V
	2	DI low: braking resistor, not controlled manually DI high: Braking resistor controlled manually (quick discharge) ²⁾ If X21.1 and X21.2 are activated simultaneously, the Braking Module inhibit has priority.	
	3	DO high: no prewarning DO low: Prewarning, disconnection imminent	Max. load current per output: 100 mA Continuously short-circuit proof Voltage: 24 V DC
	4	DO high: ready for operation, no fault DO low: Fault	
	5	Ground	
	6		
Type: Screw terminal 1 (Page 708)			

1) DI: digital input; DO: digital output; M: Electronics ground

2) The "fast discharge function" is used for discharging the capacitors in the DC link after the line supply has been interrupted. It may only be used a maximum of once or twice per week.

Terminal X21.1 - inhibit/acknowledge

Applying a high signal to terminal X21.1 inhibits the Braking Module. Fault messages that are available are acknowledged with a falling edge.

Terminal X21.3 - prewarning

When a prewarning is sent, disconnection of the braking module is imminent. This may be due to the following causes:

- The temperature of the Braking Module is 80 % of the maximum value.
- 80 % of the maximum switch on duration of the braking resistor has been reached (I²t monitoring).
- 80 % of the maximum braking energy of the braking resistor has been reached.
- An incorrect braking resistor is connected (only braking resistors approved by Siemens for this component are automatically identified).

Terminal X21.4 - fault

The fault can have the following causes:

- Electronics power supply is missing or outside permissible tolerance range
- Enable missing (input terminal)
- Overtemperature
- Overcurrent trip
- I²t monitoring has responded.
- Ground fault/short circuit

In the event of an overtemperature, the fault can only be acknowledged with X21.1 = high after a cooling-down time.



WARNING

Electric shock due to hazardous voltage at terminals X21

Hazardous voltages can be present at terminals X21 in the case of a fault. Touching live components can result in death or severe injury.

- Only connect protective extra low voltages at terminals X21.

8.2.4 Connection example

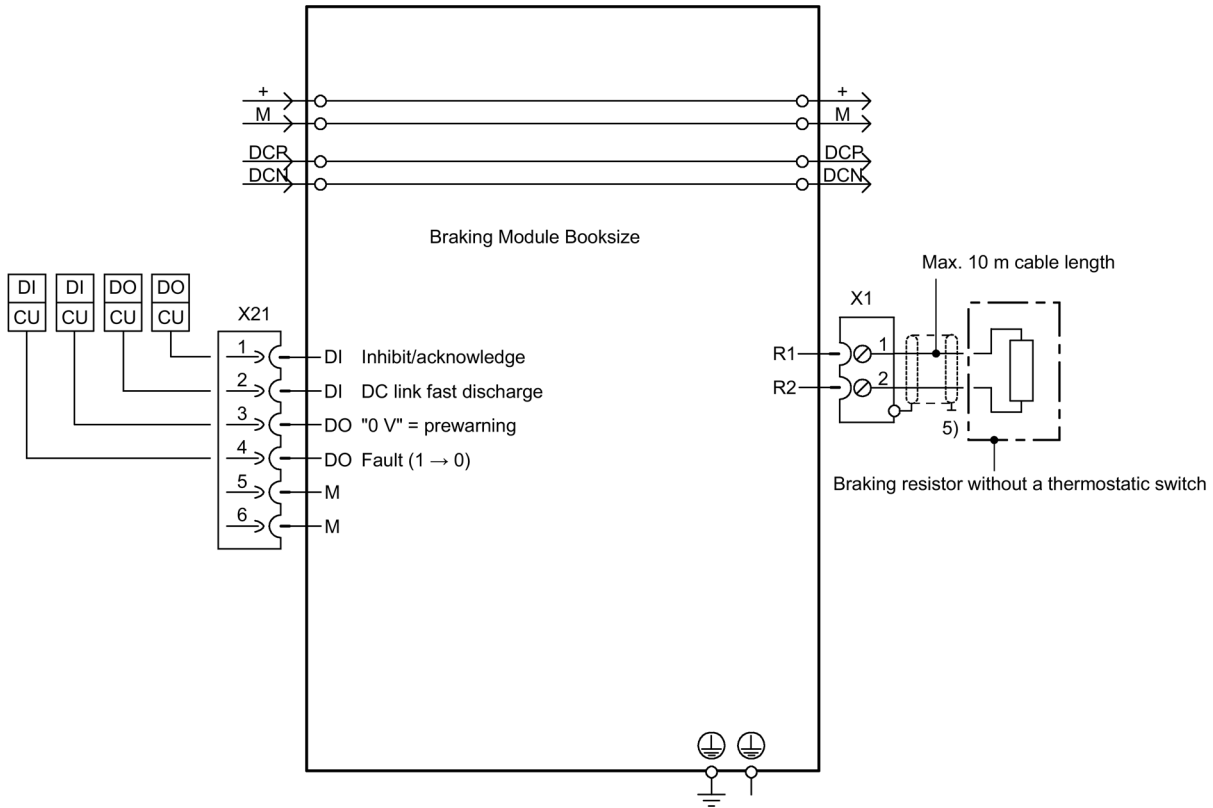

Figure 8-2 Connection example of a Braking Module Booksize

Information on how to parameterize the digital inputs or digital outputs, see the SINAMICS S120/S150 List Manual.

8.2.5 Meaning of LEDs

Table 8- 4 Meaning of the LEDs on the Braking Module Booksize

LED	Color	Status	Description, cause	Remedy
READY	-	Off	The electronics power supply is missing or outside the permissible tolerance range. The component is deactivated via terminal.	-
	Green	Continuous light	The component is ready for operation.	-
	Red	Continuous light	Enable missing (input terminal) Overtemperature Overcurrent trip I ² t monitoring activated Ground fault/short circuit Comment: In the event of an overtemperature, the error cannot be acknowledged until after a cooling down time has elapsed.	Troubleshoot the fault using the output terminals and acknowledge it using the input terminal.
DC LINK	-	Off	Only braking resistors approved by Siemens for this component are identified automatically. The component is not active.	-
	Green	Flashing light	The component is active (DC link is being discharged via the braking resistor).	-

8.2.6 Dimension drawing

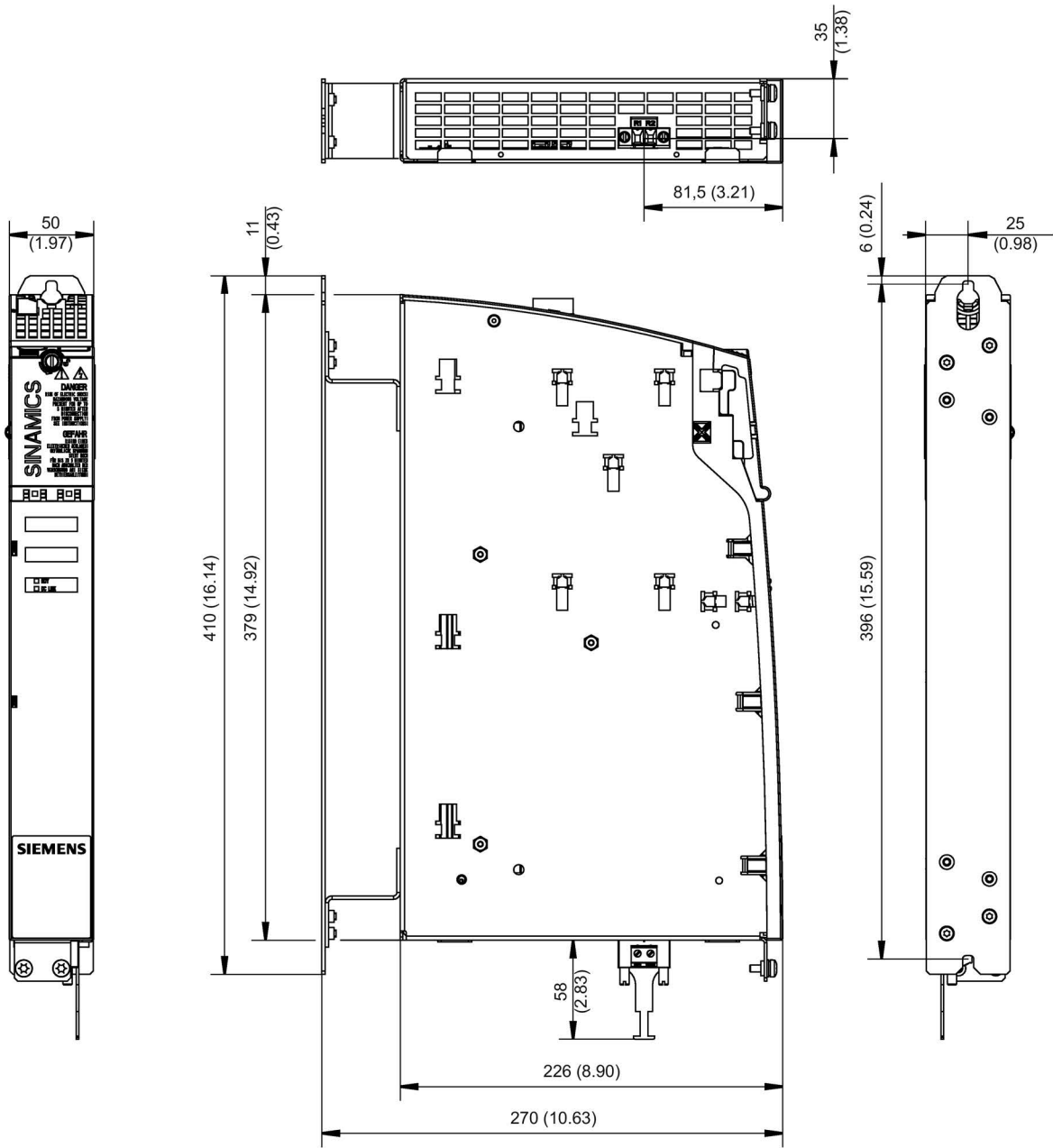
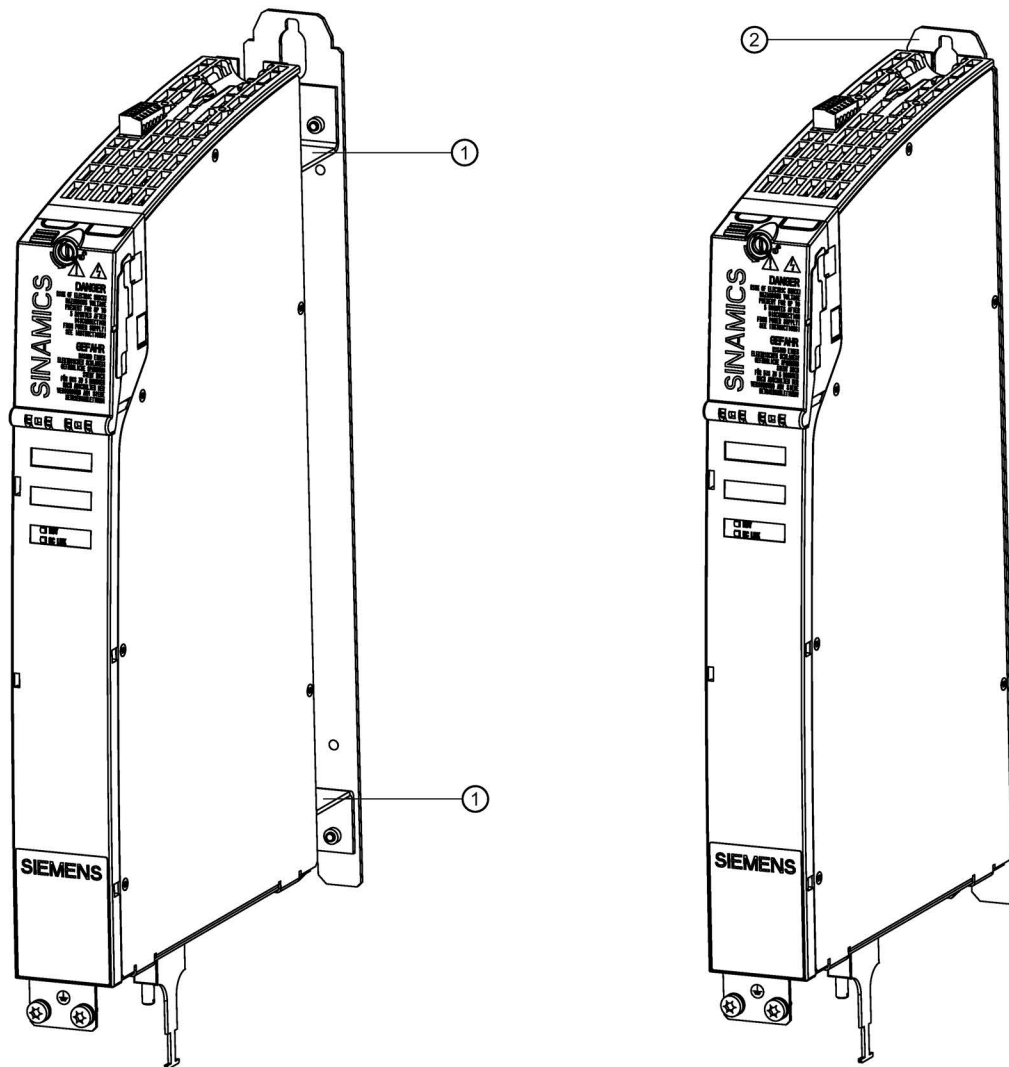

Figure 8-3 Dimension drawing of Braking Module, all dimensions in mm and (inches)

8.2.7 Installation



- ① Delivery condition with spacer - mounting depth for drive line-up in booksize format with internal air cooling
- ② Spacer removed - mounting depth for drive line-up in booksize format with external air cooling

Figure 8-4 Methods of installing Braking Modules with/without spacer elements

8.2.8 Technical data

Table 8- 5 Technical data

6SL3100-1AE31-0A..		
DC-link voltage	V_{DC}	510 ... 720
DC link capacitance	μF	110
ON threshold	V	770
Electronics power supply	V_{DC}	24 (20.4 ... 28.8)
Electronics current consumption (at 24 V DC)	A_{DC}	0.5
Current carrying capacity		
DC link busbars	A_{DC}	100
24 V busbars	A_{DC}	20
Braking power		
Maximum	kW	100
continuous braking power	kW	1.5
Power loss (see power loss tables (Page 734))	W	20
Cooling method		Natural convection
Ventilation clearances (above/below)	mm	≥ 80
Weight	kg	4.1

8.2.8.1 Characteristic curves

Duty cycle for braking resistors without a thermostatic switch

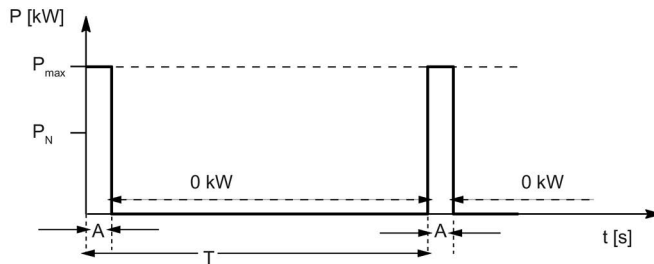

Figure 8-5 Duty cycle for braking resistors without a thermostatic switch

T [s] time period of braking duty cycle

A [s] load duration

P_N [kW] rated power (continuous power) of the braking resistor

P_{max} [kW] peak power of braking resistor ($6 \times P_N$)

Table 8- 6 Duty cycles

	6SN1113-1AA00-0DA0		6SL3100-1BE31-0AA.	
	Short duty cycle	Long duty cycle	Short duty cycle	Long duty cycle
A [s]	0.1	0.4	1	2
T [s]	11.5	210	68	460

The following applies when connecting Braking Modules in parallel:

$P_{N\ total} = 0.9 \times \text{total } P_N \text{ of single devices}$

$P_{\max\ total} = \text{total } P_{\max} \text{ of single devices}$

8.2.9 Configuration instructions

DC link capacitance

To operate Braking Modules, a minimum capacitance of 440 μF is required in the DC link for each Braking Module.

The capacitance of the Braking Module of 110 μF is included in the total capacitance value.

Note

Only the components that are connected to each other via the DC link busbar can be included in the total capacitance.

DC link cable

In a multi-row or distributed drive line-up, the DC links are connected to each other via a DC link cable. When using a Braking Module in the drive line-up, this cable must not be longer than 10 m. The DC link cable must be twisted and have a minimum cross-section of at least 10 mm^2 .

Parallel connection

The Braking Module Booksize Compact 6SL3400-1AE31-0AA. Is recommended for connecting Braking Modules in series.

Connecting Braking Modules 6SL3100-1AE31-0A.. in parallel should be avoided, as it cannot be guaranteed that the power will be evenly divided between the modules.

Note

When Braking Modules are connected in parallel, the DC link capacitance specified above must be available for each Braking Module.

8.3 Braking Module Booksize Compact

8.3.1 Description

The Braking Module Booksize Compact is always used together with a braking resistor. It has the following tasks:

- Controlled stop of the drives in the event of a power failure (e.g. emergency retraction or EMERGENCY OFF Category 1).
- Limiting of DC-link voltage for brief periods of generator operation (e.g. if the regenerative feedback capability of the Line Module is deactivated, not adequately dimensioned, or restricted due to brief line interruption)

The Braking Module includes the necessary power electronics and control. When the module is in operation, the power which is fed back into the DC link is dissipated via an external braking resistor.

The Braking Module can be operated on 200 V or 400 V line supply systems; the 4-pin DIP switch on the top of the module is used to select which one applies in each case. The factory setting is 400 V.

When spacers (6SL3462-1CC00-0AA0) are used, the Braking Module Booksize Compact can be integrated into a drive line-up in booksize format with internal air cooling.

External braking resistors

Braking resistors with or without a thermostatic switch can be used with the Braking Module Booksize Compact (List of braking resistors that can be connected (Page 484)). The DIP switch sets the type of braking resistor being used in each case. The factory setting is "braking resistor with a thermostatic switch".

The cable length between the Braking Module and the braking resistor is limited to 10 m.

Rapid discharge

Furthermore, the Braking Module Booksize Compact can be used with a braking resistor to quickly discharge the DC link. The DC link is discharged in a controlled manner via the braking resistor once the infeed unit has been switched off and the line-up has been disconnected from the line supply (e.g. via the main switch or line contactor). The function can be activated via a digital input on the Braking Module. A quick discharge makes sense, for example, when maintenance tasks are to be performed at the Motor Module and/or motor installation (reduction of the discharge time).

NOTICE

Damage to the Motor Module or connected motors for a fast discharge

For a fast discharge, the Motor Module or the connected motors can be damaged.

- For a rapid discharge, fully disconnect the drive system from the line supply.
- The motors must be at a standstill.



⚠ WARNING

Electric shock when live parts are touched after a rapid discharge

On completion of quick discharge, a voltage of 30 V is still present at the DC link. If the fast discharge is interrupted before it has been completed, then this voltage can be more than 60 V. Touching live components can result in death or severe injury.

- Check the DC link to ensure that it is in a no voltage state before starting any work.

Cooling methods

The Braking Module Booksize Compact can be operated with the following cooling methods:

- Internal air cooling
- Cold plate cooling

The required cooling method is set using the DIP switch. The factory setting is "internal air cooling".

Internal fan

When the Braking Module is being used with internal air cooling, the internal fan starts up immediately and is subsequently controlled by the temperature.

If the DIP switch is set to cold plate cooling by mistake, the fan will still start up when a certain temperature threshold is reached, in order to prevent the Braking Module shutting down due to overtemperature. If this threshold is exceeded, an alarm is issued via the digital output "Prewarning". This ensures that an emergency stop can be performed if necessary.

Monitoring functions

- Automatic detection of braking resistors without thermostatic switch and corresponding braking power monitoring (only if the "Braking resistor without thermostatic switch" setting is used)
- I²t monitoring of the Braking Module
- Temperature monitoring of the Braking Module
- Temperature monitoring of the connected braking resistor with thermostatic switch (only for setting "Braking resistor with thermostatic switch")
- Short-circuit and overload detection (for all braking resistors)
- Ground fault detection (for all braking resistors)

Parallel operation

Several Braking Modules Booksize Compact can be connected in parallel to increase the braking power. In this case, the braking energy is divided between the modules. Formulas for calculating the parallel connection are given in Chapter Notes on configuration (Page 496).

A parallel connection of the Braking Module Booksize Compact to SINAMICS S120 Basic Line Modules 20 kW and 40 kW is also possible.

8.3.2 Safety instructions for Braking Modules Booksize Compact

NOTICE
Device failure as a result of unshielded or incorrectly routed cables to braking resistors
Unshielded or incorrectly routed cables to braking resistors can result in interference being coupled into the signal processing electronics from the power side. This can result in significant disturbance of all signals (fault messages) up to failure of individual components (destruction of the devices).
<ul style="list-style-type: none">• Only use shielded cables for cables to braking resistors.

NOTICE
Danger to life through the use of non-approved braking resistors
Braking resistors can be damaged when using braking resistors other than those specified in this Manual.
<ul style="list-style-type: none">• Only use braking resistors approved by Siemens.

8.3.3 Interface description

8.3.3.1 Overview

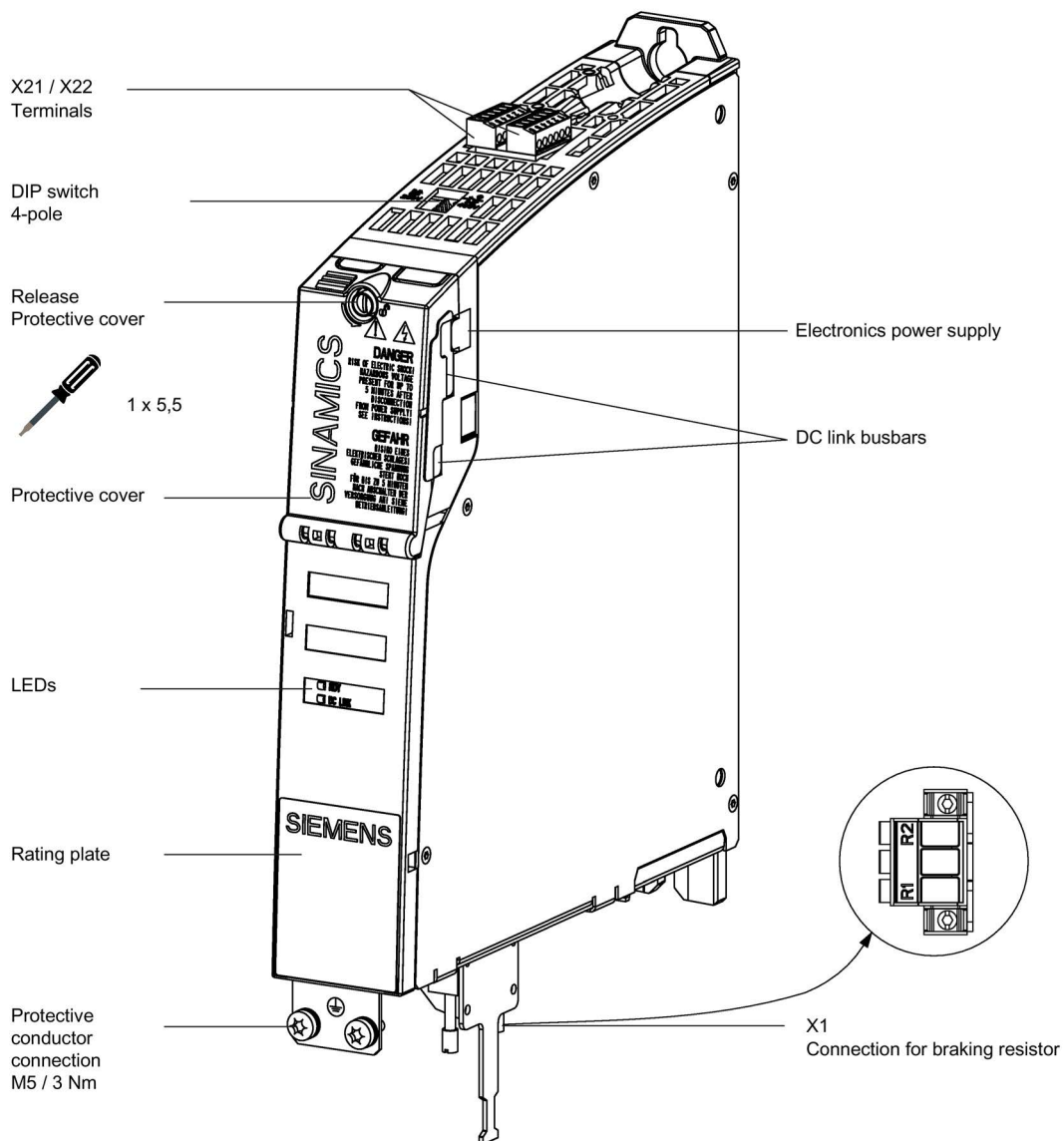
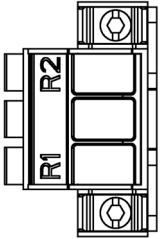

Figure 8-6 Interface overview, Braking Module Booksize Compact

8.3.3.2 X1 braking resistor connection

Table 8- 7 X1 braking resistor connection

	Terminal	Designation	Technical data
	1	Braking resistor connection R1	Continuously short-circuit proof
	2	Not assigned	
3	Braking resistor connection R2		
Type: Screw terminal 5 (Page 708)			

Braking resistors without a thermostatic switch

The Braking Module Booksize Compact is only designed for operation with the braking resistors listed below.

Table 8- 8 Braking resistors without a thermostatic switch

Braking resistor	R in Ω	P _N in kW	P _{max} in kW
6SN1113-1AA00-0DA0	17	0.3	25
6SL3100-1BE31-0AA0	5.7	1.5	100

Braking resistors with a thermostatic switch

The Braking Module Booksize Compact is only designed for operation with the braking resistors listed below.

Table 8- 9 Braking resistors with a thermostatic switch

Braking resistor	R in Ω	P _N in kW	P ₂₀ in kW	P _{max} in kW
6SE7018-0ES87-2DC0	80	1.25	5	7.5
6SE7021-6ES87-2DC0	40	2.5	10	15
6SE7023-2ES87-2DC0	20	5	20	30

For detailed technical information on the braking resistors, see Chapter Braking resistors (Page 529).

8.3.3.3 X21 digital inputs/outputs

Table 8- 10 X21 digital inputs/outputs

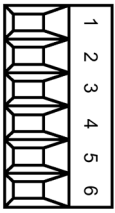
	Terminal	Designation ¹⁾	Technical data
	1	DI low: Enable Braking Module DI high: Inhibit/acknowledgement Edge change, high → low: fault acknowledgement	Voltage: -3 ... +30 V Typical current drain: 10 mA at 24 V DC Level (incl. ripple) High level: 15 ... 30 V Low level: -3 ... +5 V
	2	DI low: braking resistor, not controlled manually DI high: Braking resistor controlled manually (quick discharge) ²⁾ If X21.1 and X21.2 are activated simultaneously, the Braking Module inhibit has priority.	
	3	DO high: no prewarning DO low: Prewarning:	Max. load current per output: 100 mA Continuously short-circuit proof Voltage: 24 V DC
	4	DO high: ready for operation, no fault DO low: Fault	
	5	Ground	
	6		
Type: Screw terminal 1 (Page 708)			

1) DI: digital input; DO: digital output; M: Electronics ground

2) The "fast discharge function" is used for discharging the capacitors in the DC link after the line supply has been interrupted.

Terminal X21.1 - inhibit/acknowledge

Applying a high signal to terminal X21.1 inhibits the Braking Module. Fault messages that are available are acknowledged with a falling edge.

Terminal X21.3 - prewarning

When a prewarning is sent, disconnection of the braking module is imminent. This may be due to the following causes:

- The temperature switch braking resistor has triggered (only if the "Braking resistor with thermostatic switch" setting is used)
- The temperature of the Braking Module is 80 % of the maximum value.
- The I²t counter of the Braking Module has reached 80 % of the maximum value.
- The braking resistor has reached 80 % of the maximum permissible braking energy (only for setting "Braking resistor without thermostatic switch").
- An incorrect braking resistor is connected (only if the "braking resistor without a thermostatic switch" setting is used).

Terminal X21.4 - fault

In the event of an overtemperature fault, I²t monitoring, or braking power monitoring, the fault will be acknowledged automatically after a cooling phase. Manual acknowledgment is not necessary!



 WARNING
<p>Electric shock due to hazardous voltage at terminals X21</p> <p>Hazardous voltages can be present at terminals X21 in the case of a fault. Touching live components can result in death or severe injury.</p> <ul style="list-style-type: none"> • Only connect protective extra low voltages at terminals X21.

8.3.3.4 X22 digital output/temperature switch

Table 8- 11 X22 digital output/temperature switch, braking resistor

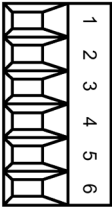
	Terminal	Designation ¹⁾	Technical data
	1	+ Temp	Temperature switch of the braking resistor
	2	- Temp	
	3	Reserved, do not use	
	4	Reserved, do not use	
	5	DO high: 200 V supply system is selected DO low: 400 V supply system is selected	
	6	Reserved, do not use	
Type: Screw terminal 1 (Page 708)			

¹⁾ DO: digital output

8.3.3.5 DIP switch

The 4-pin DIP switch is located at the top of the Braking Module and sets the braking resistor being used, the cooling method, and the line voltage.

Make the required settings before the Braking Module is mounted in the control cabinet; once the module is mounted, the DIP switch can no longer be accessed from the front.

Table 8- 12 DIP switch for Braking Module Booksize Compact

	Switch	Switch position	Function	Factory setting
	1	ON	Braking resistor without a thermostatic switch	OFF
		OFF	Braking resistor with a thermostatic switch	
	2	ON	Cold plate cooling	OFF
		OFF	Internal air cooling	
	3	ON	200 V line voltage	OFF
		OFF	400 V line voltage	
	4	ON	Reserved	OFF
		OFF		

Note

Terminal assignment for "Braking resistor without a thermostatic switch" mode

For "braking resistor without a thermostatic switch" mode (switch 1 = ON) , terminals X22.1 and X22.2 must not be assigned for the Braking Module to work.

8.3.4 Connection examples

Braking resistor without thermostatic switch connected to a Braking Module Booksize Compact

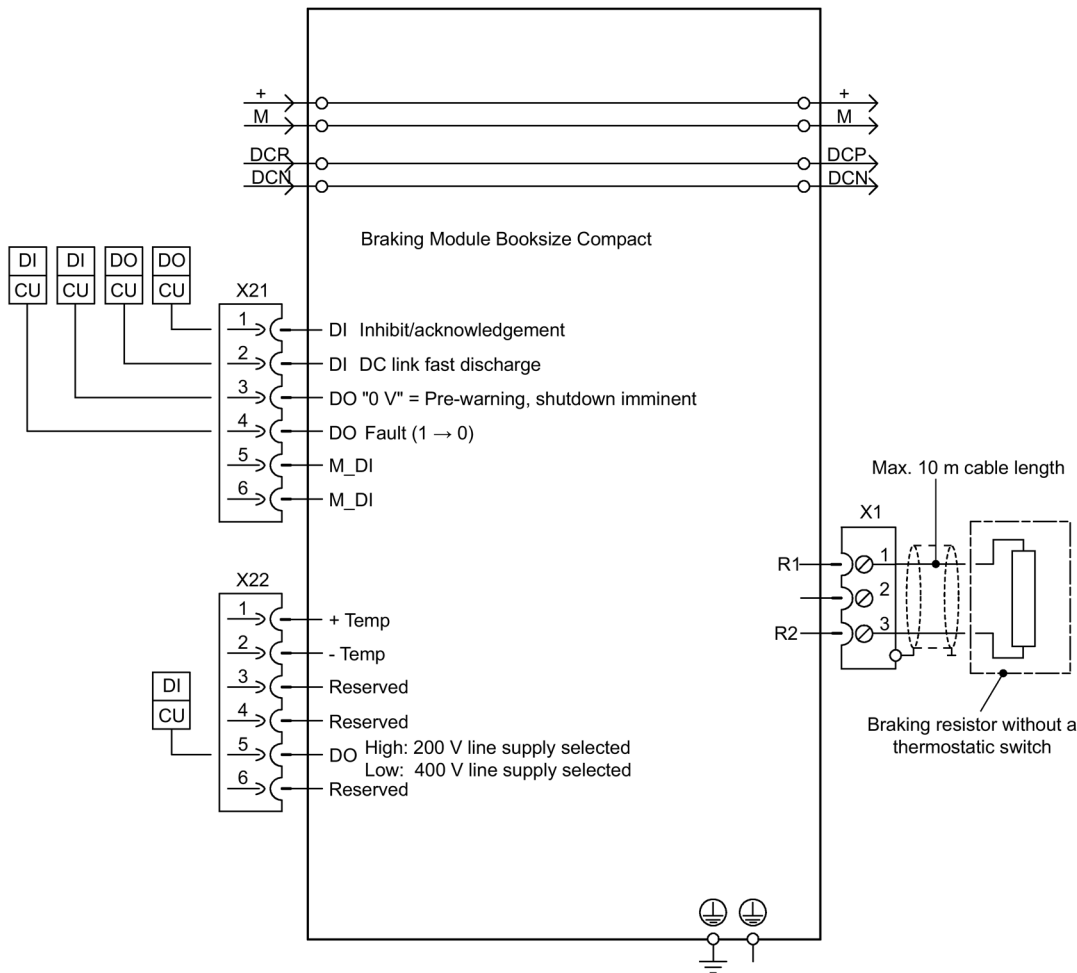

Figure 8-7 Connection example for Braking Module Booksize Compact and braking resistor without a thermostatic switch

Note

The digital inputs DI are isolated and are referenced to M_DI (X21.5 and X21.6).
 The reference point of the digital outputs DO is the ground GND of the 24 V supply.

It is not permissible that the connections for the temperature switches (X22.1 and X22.2) are used/assigned for "braking resistor without a thermostatic switch" operation. Otherwise, malfunctions occur.

Braking resistor with thermostatic switch connected to a Braking Module Booksize Compact

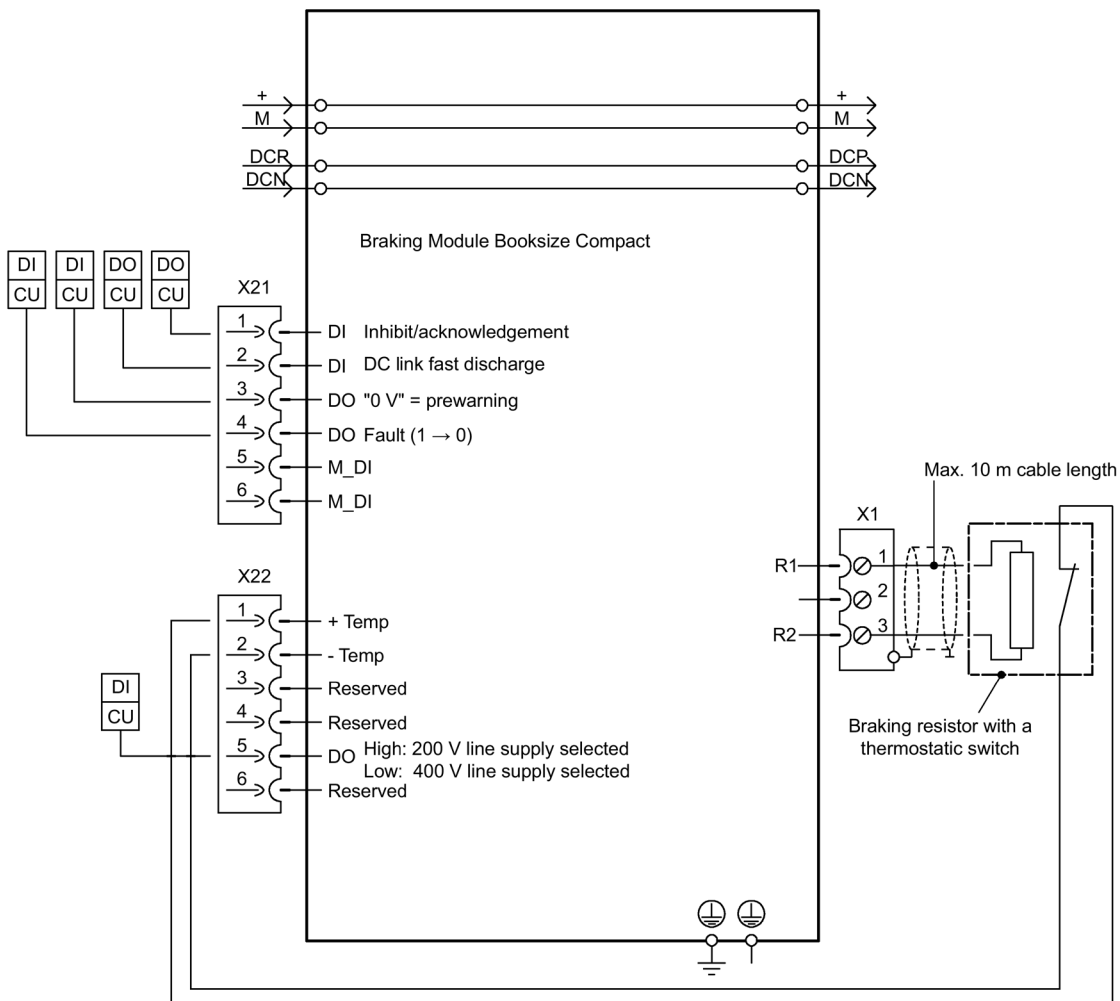

Figure 8-8 Connection example for Braking Module Booksize Compact and braking resistor with a thermostatic switch

Note

The digital inputs (DI) are isolated and are referenced to M_DI (X21.5 and X21.6).
The reference point of the digital outputs (DO) is the ground GND of the 24 V supply.

Information on how to parameterize the digital inputs or digital outputs, see the SINAMICS S120/S150 List Manual.

8.3.5 Meaning of LEDs

Table 8- 13 Meaning of LEDs on the Braking Module Booksize Compact

LED	Color	Status	Description	Remedy
READY	-	Off	The electronics power supply is missing or outside the permissible tolerance range.	Check the electronics power supply.
	Green	Continuous light	The component is ready for operation.	-
	Red	Continuous light	Enable missing (input terminal) Overtemperature of IGBT/braking resistor Overcurrent trip I ² t monitoring activated Braking power monitoring triggered Ground fault/short circuit Comment: In the event of overtemperature, I ² t monitoring or braking power monitoring, the fault will be acknowledged automatically after a cooling down phase. Manual acknowledgment is not possible.	Troubleshoot the fault using the output terminals and acknowledge it using the input terminal.
DC LINK	-	Off	The DC link voltage is not available, the electronics power supply is missing or is outside the permissible tolerance range. The component is not active.	
	Orange	Continuous light	The DC link voltage is present.	-
	Orange	Flashing light	The component is active. The DC link is being discharged via the braking resistor.	-

8.3.6 Dimension drawing

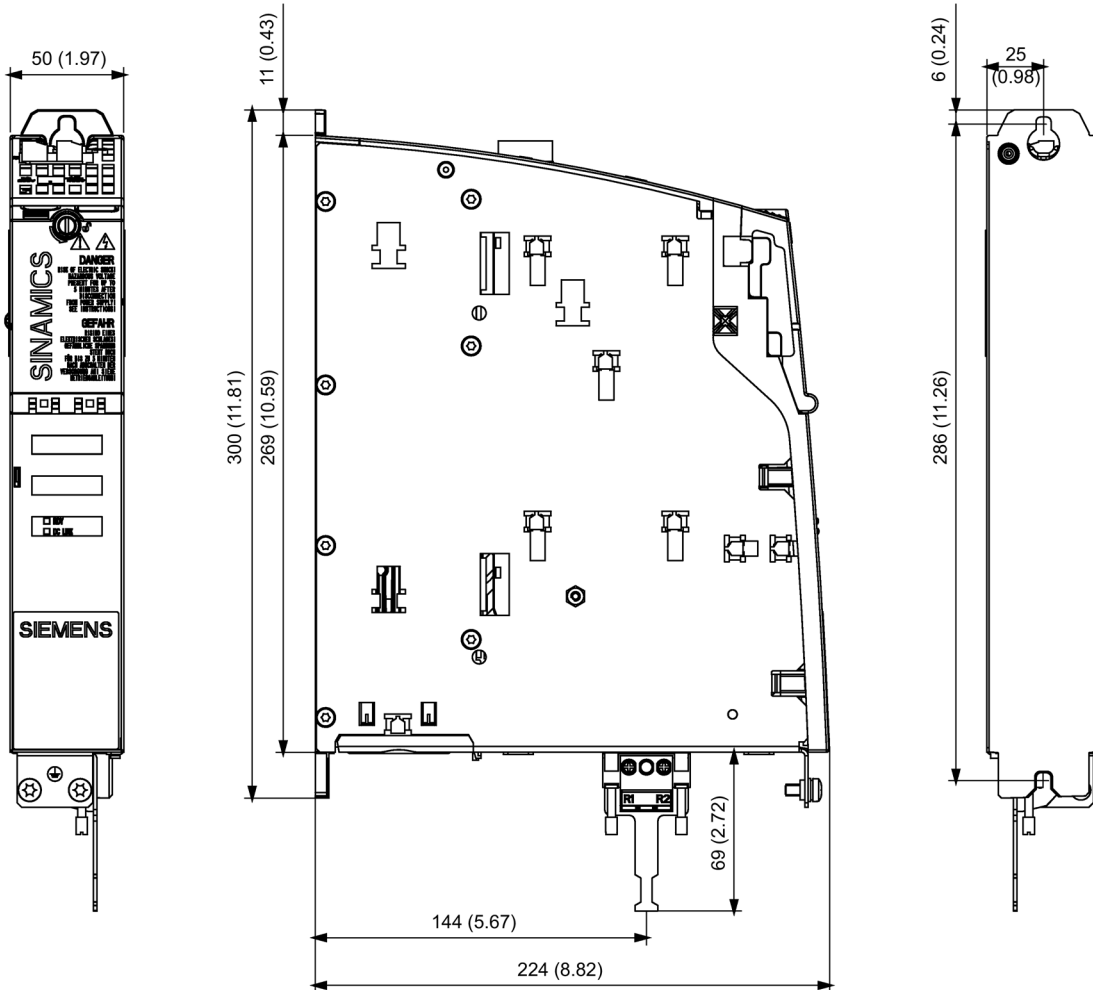
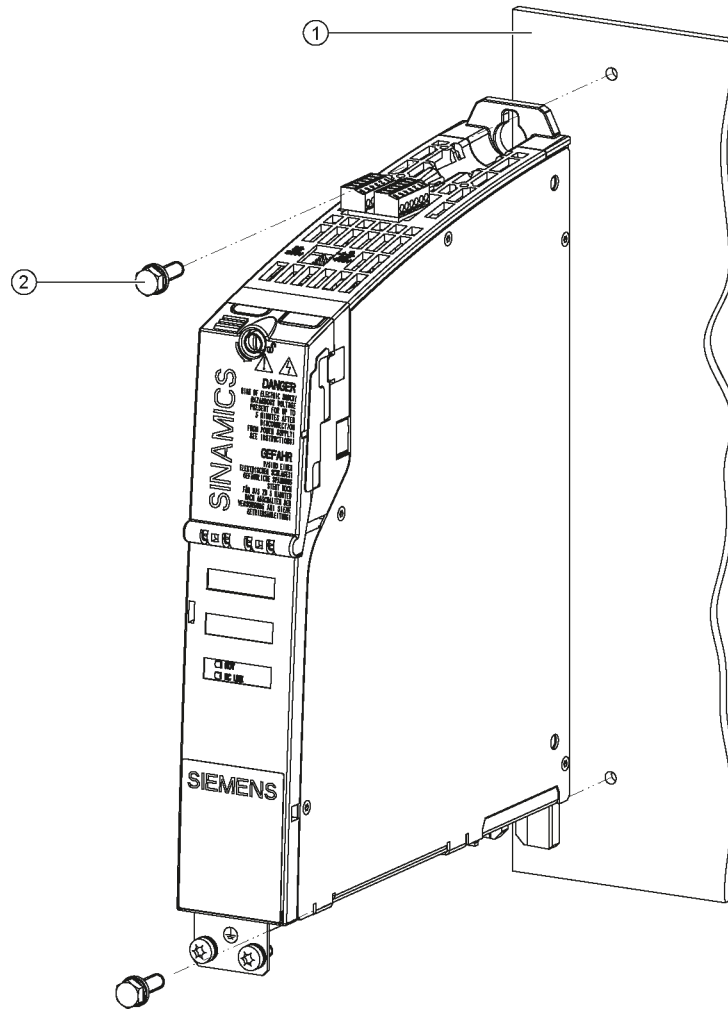

Figure 8-9 Dimension drawing of Braking Module Booksize Compact, all dimensions in mm and (inches)

8.3.7 Mounting

Mounting a Braking Module Booksize Compact with internal air cooling



- ① Mounting wall
- ② M6 x 16 screw
Hex combination screw or hex screw with spring washer and plain washer

Figure 8-10 Mounting a Braking Module Booksize Compact with internal air cooling

Tightening torques:

1. Firstly, tighten the nuts by hand.
Tightening torque: 0.5 Nm (4.4 lbf in)
2. Then tighten the nuts.
Tightening torque: 6 Nm (53.1 lbf in)

Mounting a Braking Module Booksize Compact with cold plate

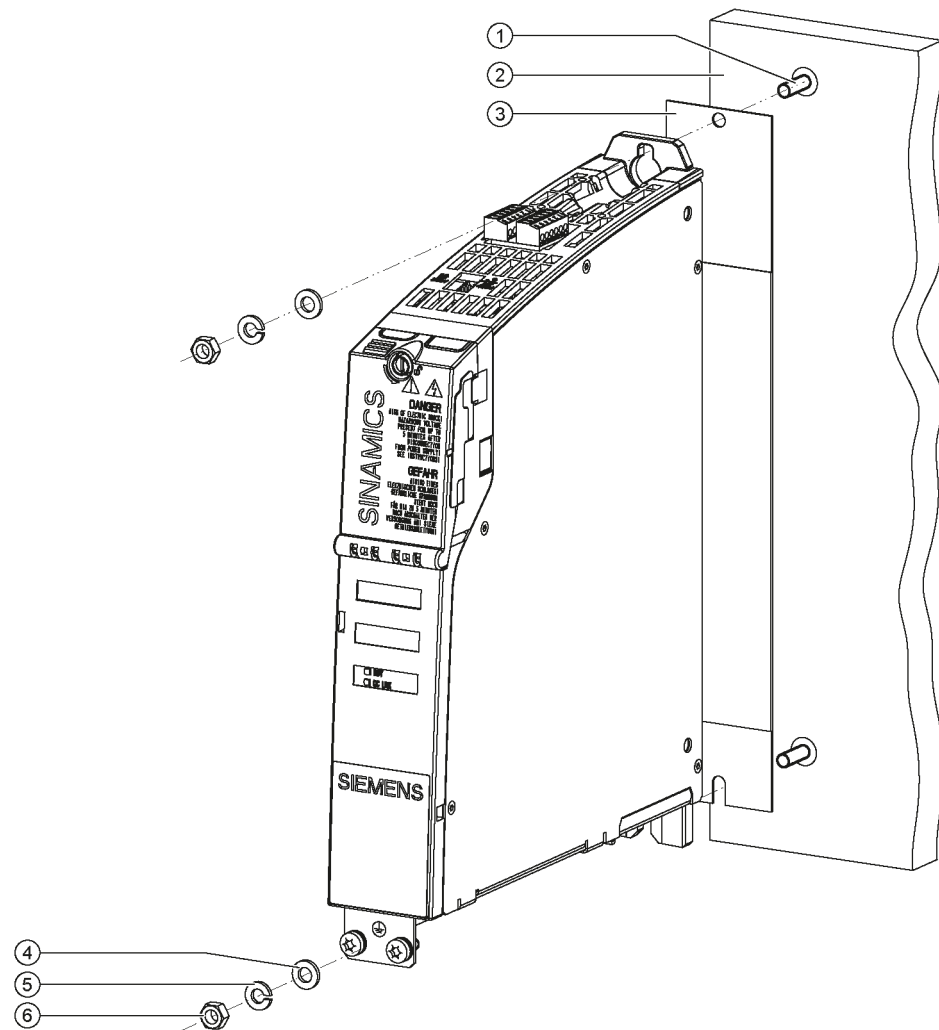

- ① Threaded bolts M6
- ② Cold plate (air or liquid cooling)
- ③ Heat-conducting foil
- ④ Washer
- ⑤ Spring washer
- ⑥ M6 nut

Figure 8-11 Mounting a Braking Module Booksize Compact with cold plate

Tightening torques:

1. Firstly, tighten the nuts by hand.
Tightening torque: 0.5 Nm (4.4 lbf in)
2. Then tighten the nuts.
Tightening torque: 10 Nm (88.5 lbf in)

Special points to note in relation to mounting on a cold plate

To improve heat transfer, a heat-conducting medium must be used. Special spherical-indented heat-conducting foil must be used for this purpose. Every Braking Module Booksize Compact is supplied with heat-conducting foil cut to the right size. Note the mounting position of the heat-conducting foil.

Note

- Also replace the heat-conducting foil when replacing a component.
- Only use heat-conducting foil released or supplied by Siemens.

	Article No.
Heat-conducting foil, 50 mm	6SL3162-6FB01-0AA0

8.3.8 Technical specifications

Table 8- 14 Technical data

6SL3400-1AE31-0AA.			
Line supply		200 V	400 V
DC-link voltage	V _{DC}	250 ... 360	510 ... 720
ON threshold	V _{DC}	400	760
Braking power			
Maximum ¹⁾	kW	50	100
Continuous braking power	kW	2.5	5
Electronics power supply	V _{DC}	24 (20.4 ... 28.8)	
Electronics current consumption (at 24 V DC)			
Standby mode	A _{DC}	0.2	
	A _{DC}	0.4	
Current carrying capacity:			
DC link busbars	A _{DC}	100	
24 V busbar	A _{DC}	20	
Power loss (see power loss tables (Page 734))			
Standby operation	W	5	
	W	25	
Switching frequency	Hz	2000	
Cooling methods		Internal air cooling Cold plate cooling	
Ventilation clearances (above/below)	mm	≥ 80	
Max. ambient temperature	°C	55	
Weight	kg	2.7	

¹⁾ At the upper switch-on threshold

8.3.8.1 Characteristic curves

Duty cycle for braking resistors without a thermostatic switch

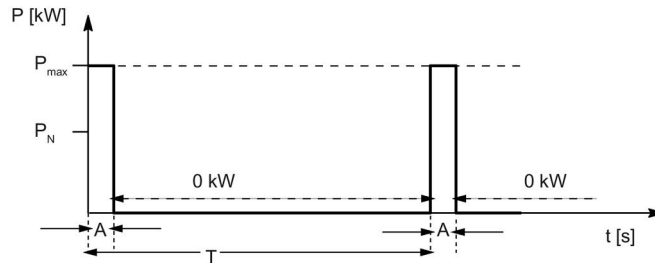

Figure 8-12 Duty cycle for braking resistors without a thermostatic switch

T [s] time period of braking duty cycle

A [s] load duration

P_N [kW] rated power (continuous power) of the braking resistor

P_{max} [kW] peak power of braking resistor ($6 \times P_N$)

Table 8- 15 Duty cycles

	6SN1113-1AA00-0DA0		6SL3100-1BE31-0AA.	
	Short duty cycle	Long duty cycle	Short duty cycle	Long duty cycle
A [s]	0.1	0.4	1	2
T [s]	11.5	46	68	136

Duty cycles for braking resistors with a thermostatic switch

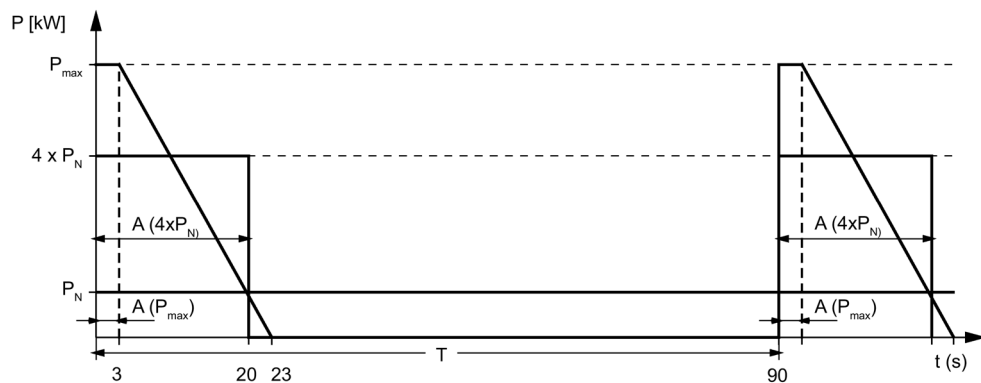

Figure 8-13 Duty cycles for braking resistors with a thermostatic switch

T [s] time period of braking duty cycle

A [s] load duration

P_N [kW] rated power (continuous power) of the braking resistor

P_{max} [kW] peak power of braking resistor ($6 \times P_N$)

$4 \times P_N$ [kW] = power permitted every 90 s for 20 s

Table 8- 16 Duty cycles

	6SE7018-0ES87-2DC0		6SE7021-6ES87-2DC0		6SE7023-2ES87-2DC0	
	Duty cycle P _{max}	Duty cycle 4 x P _N	Duty cycle P _{max}	Duty cycle 4 x P _N	Duty cycle P _{max}	Duty cycle 4 x P _N
A [s]	3	20	3	20	3	20
T [s]	90	90	90	90	90	90

8.3.9 Configuration instructions

DC link capacitance

When configuring the drive line-up, please note that only one Braking Module Booksize Compact may be used per complete 500 µF DC link capacitance.

Table 8- 17 Configuration examples

DC link capacitance in µF	Max. number of Braking Modules
900	1
2400	4
9,800	19

DC link cable

In a multi-row or distributed drive line-up, the DC links are connected to each other via a DC link cable. When using a Braking Module Booksize Compact in the drive line-up, this cable must not be longer than 10 m. In all cases, the DC link cable must have low impedance and a cross-section of at least 10 mm².

Parallel operation

During configuration of parallel operation for Braking Modules Booksize Compact, dimensioning can only take 90% of the specified braking power into account. Only the peak powers may be added without derating.

The following applies when connecting Braking Modules in parallel:

$$P_{N \text{ total}} = 0.9 \times \text{total } P_N \text{ of single devices}$$

$$4 \times P_{N \text{ total}} = 0.9 \times \text{sum } (4 \times P_N) \text{ of single devices}$$

$$P_{\text{max total}} = \text{total } P_{\text{max}} \text{ of single devices}$$

8.4 Braking units for 100 kW Basic Line Modules

8.4.1 Description

Since Basic Line Modules 100 kW cannot feed power back into the supply system, an external braking unit together with a braking resistor is required for the following tasks:

- When the power fails, the drives are stopped in a controlled fashion (e.g. EMERGENCY OFF Category 1).
- The DC link voltage is limited during brief generator operation.

The MASTERDRIVES braking unit includes the necessary power electronics and control. When the braking unit is in operation, the power which is fed back into the DC link is dissipated via an external braking resistor.

For the operation of a Basic Line Module 100 kW, only MASTERDRIVES braking units with the following rated braking powers are permitted:

- $4 \times P_N = 100 \text{ kW}$ (Article number 6SE7031-6EB87-2DA1)
- $4 \times P_N = 170 \text{ kW}$ (Article number 6SE7032-7EB87-2DA1)

For detailed information about the MASTERDRIVES braking unit, see operating instructions "MASTERDRIVES braking unit" with article number 6SE7087-6CX87-2DA0.

8.4.2 Safety instructions for Braking Modules for the 100 kW Basic Line Module

NOTICE

Device failure as a result of unshielded or incorrectly routed cables to braking resistors

Unshielded or incorrectly routed cables to braking resistors can result in interference being coupled into the signal processing electronics from the power side. This can result in significant disturbance of all signals (fault messages) up to failure of individual components (destruction of the devices).

- Only use shielded cables for cables to braking resistors.

Note

Note the starting time for the electronics

The electronics of the Braking Module is supplied from the DC link. As long as no DC-link voltage is present ($< 360 \text{ V} \pm 2\%$), the electronics are not active and an external control or the Control Unit receives the "fault" signal from the fault output. This means that it is not just the 2 seconds that has to be taken into account, which the electronics requires to run up as soon as the DC-link voltage is present.

NOTICE

Danger to life through the use of non-approved braking resistors



Braking resistors can be damaged when using braking resistors other than those specified in this Manual.

- Only use braking resistors approved by Siemens.

8.4.3 Interface description

8.4.3.1 X3 DC link connection

Table 8- 18 X3: Connection for the DC link



Connection/Meaning	Remarks	Tightening torque
C/L+ input (plus DC link)	Busbar C/L+	16 Nm (142 lbf in)
D/L- input (minus DC link)	Busbar D/L	16 Nm (142 lbf in)
 Protective conductor	Busbar PE 	16 Nm (142 lbf in)
Shield connection	M6 bolts at top of housing	8 Nm (70.8 lbf in)
Connection via	Cable lug without insulation (Page 710) With shrink-on sleeve Cable is connected using the supplied M8 x 25 screws	
AWG	Maximum 2/0	

Note

After the DC-link voltage is applied, fault output -X38/5 is "low" for approx. 2 seconds (self-test), i.e. in the "fault" state. The Control Unit must suppress this state when the system is switched on.

8.4.3.2 X6 braking resistor connection

Table 8- 19 X6: Connection for the braking resistor

Connection/Meaning	Remarks	Tightening torque
G/R+ external braking resistor	Busbar G/R+	16 Nm (142 lbf in)
H/R external braking resistor	Busbar H/R	16 Nm (142 lbf in)
 Protective conductor	Busbar PE 	16 Nm (142 lbf in)
Shield connection	M6 bolts at bottom of housing	8 Nm (70.8 lbf in)
Connection via	Cable lug without insulation (Page 710) With shrink-on sleeve Cable is connected using the supplied M8 x 25 screws	
AWG	Maximum 2/ 0	

Note

The cable length between the braking unit and the braking resistor is limited to 15 m.

The following braking resistors are suitable for connecting to the MASTERDRIVES braking unit:

Table 8- 20 Braking resistors for MASTERDRIVES braking unit

Braking resistor	P_N in kW	P_{20} in kW	P_{max} in kW	R in Ω
6SE7031-6ES87-2DC0	25	100	150	4
6SE7032-7ES87-2DC0	42.5	170	255	2.35

8.4.3.3 Switch S1

Switch S1 on the MASTERDRIVES braking unit is used to set the switch-on threshold. It is located behind the front panel.

Switch S1 should be set to "high" (factory setting) in order to operate the braking unit on a SINAMICS S120 drive line-up in booksize format. This means that the switch-on threshold is at 757 V DC.

For more information, refer to the operating instructions for the MASTERDRIVES braking unit.

8.4.4 Connection example

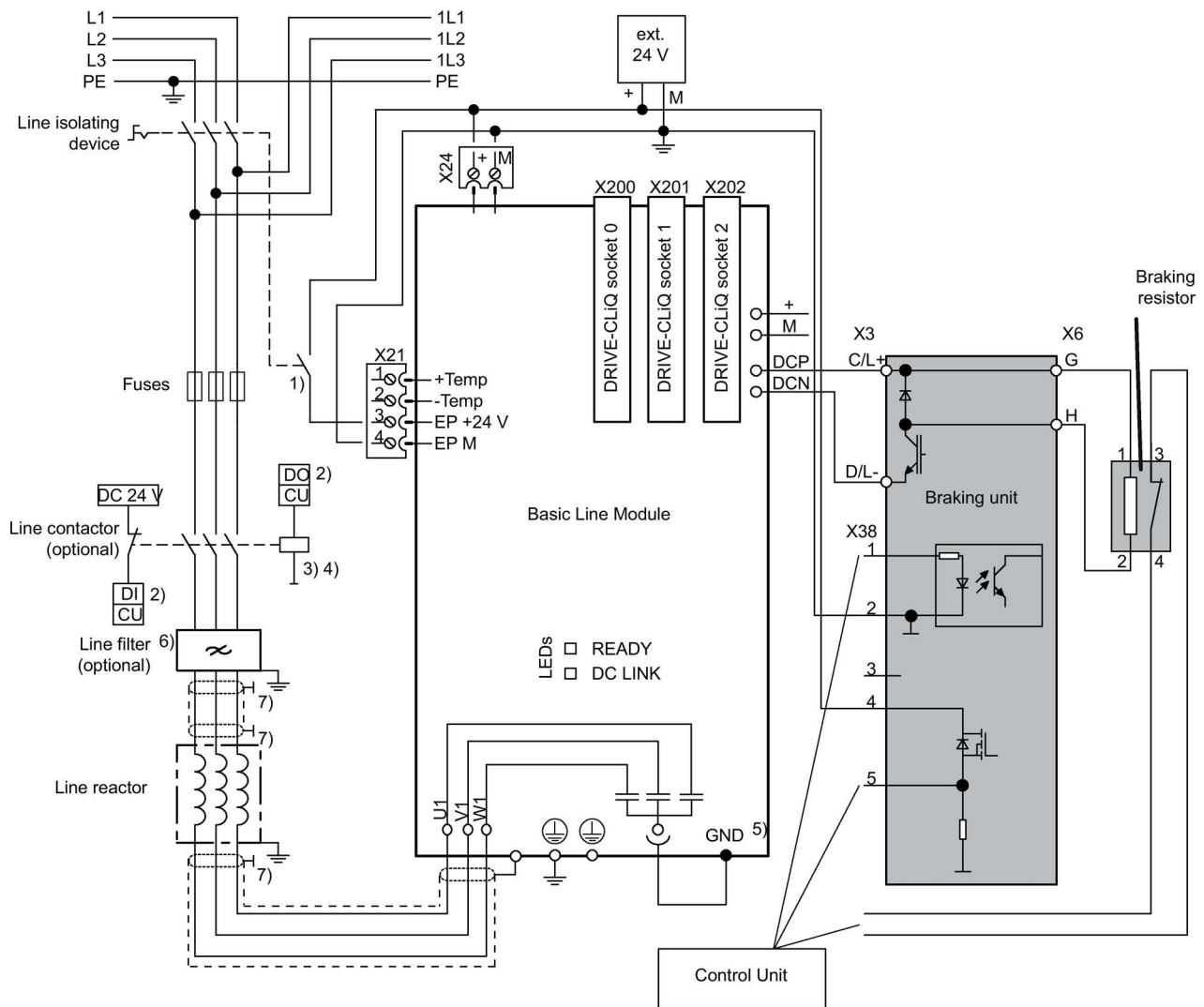

- 1) 24 V DC and ground must be connected for operation.
- 2) DI/DO, controlled by the Control Unit.
- 3) No additional load permitted downstream of the line contactor!
- 4) The current carrying capacity of the DO must be observed; an output coupling device may have to be used.
- 5) The connection bracket must be removed for operation of the components in the IT system.
- 6) Line filter is required to ensure compliance with radio interference voltage of Category C2.
- 7) Contact is established via the rear of the mounting plate - or shield bars according to the EMC installation directive.

Figure 8-14 Connection example for MASTERDRIVES braking unit

8.4.5 Dimension drawing

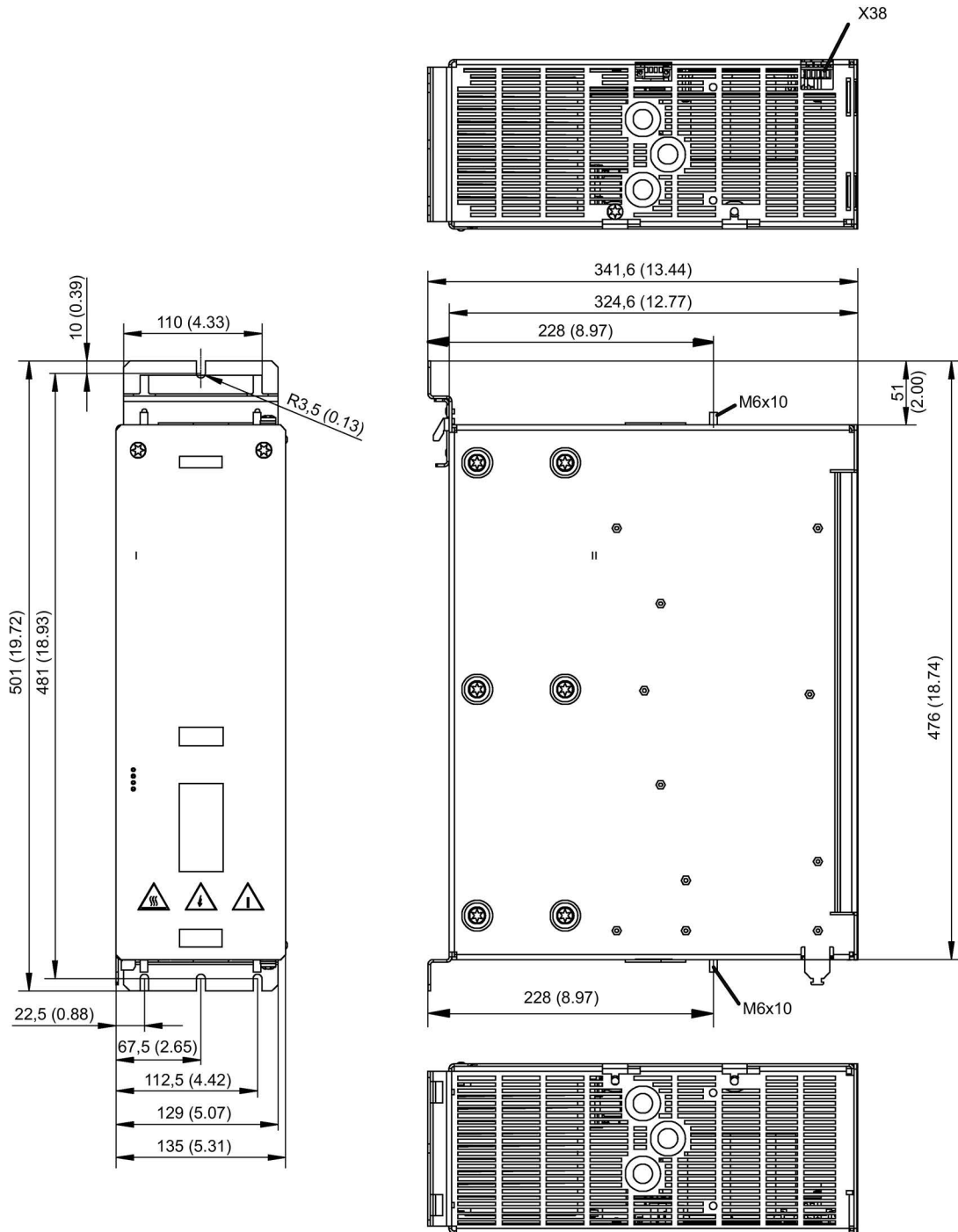

Figure 8-15 Dimension drawing of 100 kW and 170 kW MASTERDRIVES braking unit, all dimensions in mm and (inches)

8.4.6 Connection to the Basic Line Module 100 kW

Connecting the braking unit to the DC link

The following adapters can be used to connect the MASTERDRIVES braking unit to a SINAMICS S120 line-up in booksize format:

- DC link rectifier adapter, Article number 6SL3162-2BM00-0AA0
- DC link adapter, Article number 6SL3162-2BM01-0AA0

The connecting cables used to connect the braking unit to the DC link rectifier adapter or DC link adapter must be kept as short as possible.

Please observe the instructions contained in Chapters DC link rectifier adapter (Page 605) and DC link adapter (Page 617).

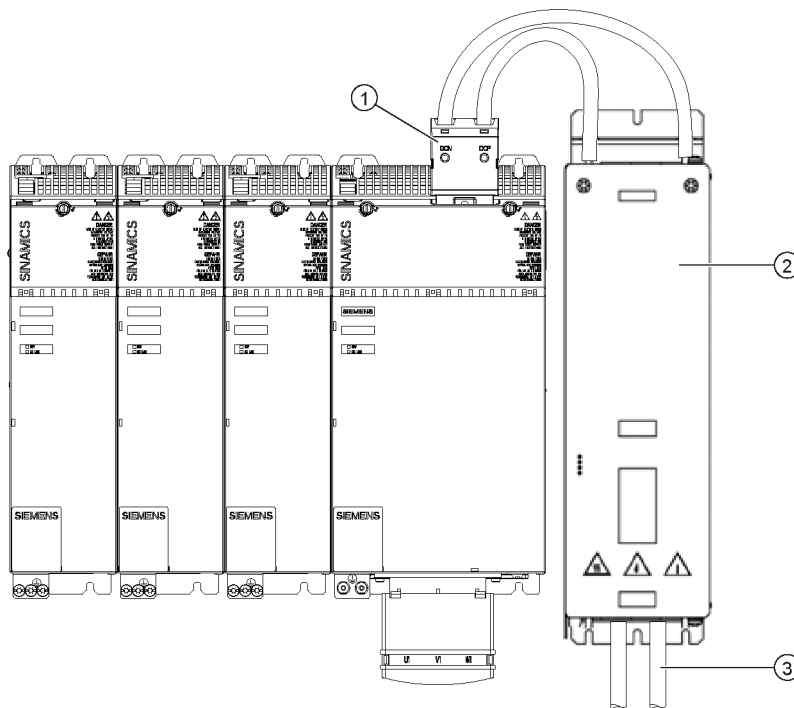

- ① DC link rectifier adapter
- ② MASTERDRIVES braking unit
- ③ Cable routing to the braking resistor

Figure 8-16 Connecting a MASTERDRIVES braking unit via a DC link rectifier adapter

Connecting the braking unit to the DC link adapter or DC link rectifier adapter

1. Connect the C/L+ connection on the braking unit to the DCP terminal on the DC link rectifier adapter or DC link adapter.
2. Connect the D/L- connection on the braking unit to the DCN terminal on the DC link rectifier adapter or DC link adapter.
3. Connect the protective conductor between the S120 drive line-up and the braking unit. According to diagram "Grounding concept SINAMICS S120 Booksize" (Page 714) the cross-section of the protective conductor connection must be 6 mm² (AWG 10).

The connecting cable between the braking unit and the DC link rectifier adapter or DC link adapter must be dimensioned with a cross-section of 95 mm² (AWG 3/0) in accordance with EN 60439-1 (short-circuit-proof cable routing). The electric strength of the cable must be rated to the line voltage. The maximum permissible length of the connecting cables to the DC link is 3 m.

NOTICE

Damage to equipment resulting from interchanging or short circuiting of DC link terminals

The drive equipment or braking unit may be damaged if the DC link terminals are interchanged or short-circuited.

- Carefully ensure that the DC link terminals are correctly connected.
- Do not short-circuit the DC link terminals.



CAUTION

Burns due to high braking unit temperature

The air discharge temperature of the braking units and the housing can become very hot. Contact could cause injury.

- Avoid coming into contact with the discharged air and the housing of the braking units.
- Mount the motor braking units so that they cannot be touched. If this is not possible, attach a clearly visible and understandable warning notice at hazardous positions.
- To prevent adjacent components from being damaged due to these high temperatures, maintain a clearance around all sides of the braking units.

8.5 Capacitor Module

8.5.1 Description

Capacitor modules are used to increase the DC link capacitance to bridge momentary power losses.

Capacitor modules are connected to the DC-link voltage via the integrated DC link busbars. Capacitor modules function autonomously.

Several capacitor modules can be operated in parallel.

Note

Maximum permissible DC link capacitance

The Capacitor Module is precharged by the Line Module.

- Observe the respective maximum permissible DC link capacitances of the Line Modules.
-

8.5.2 Interface description

8.5.2.1 Overview

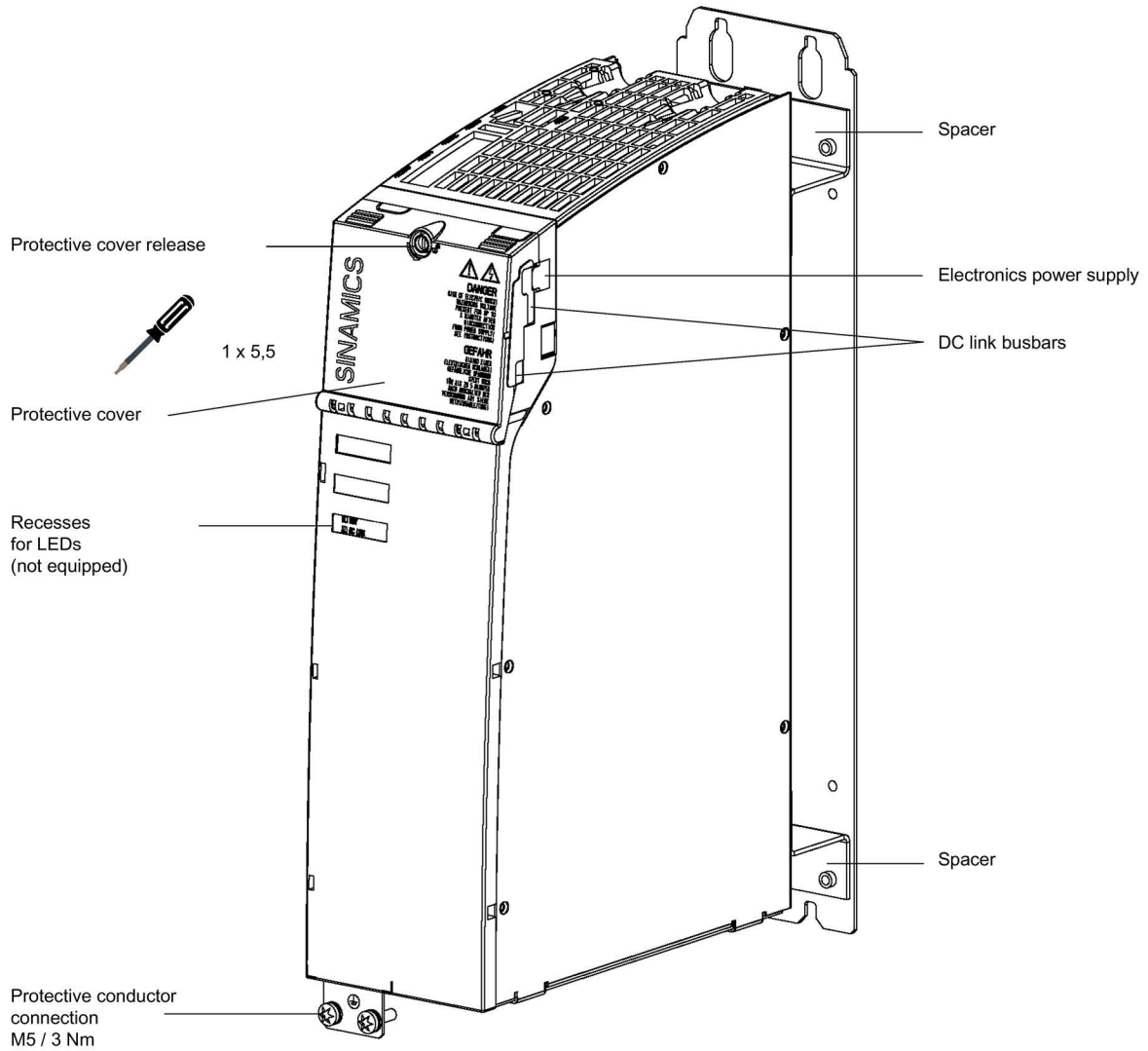

Figure 8-17 Interface overview, Capacitor Module

8.5.3 Dimension drawing

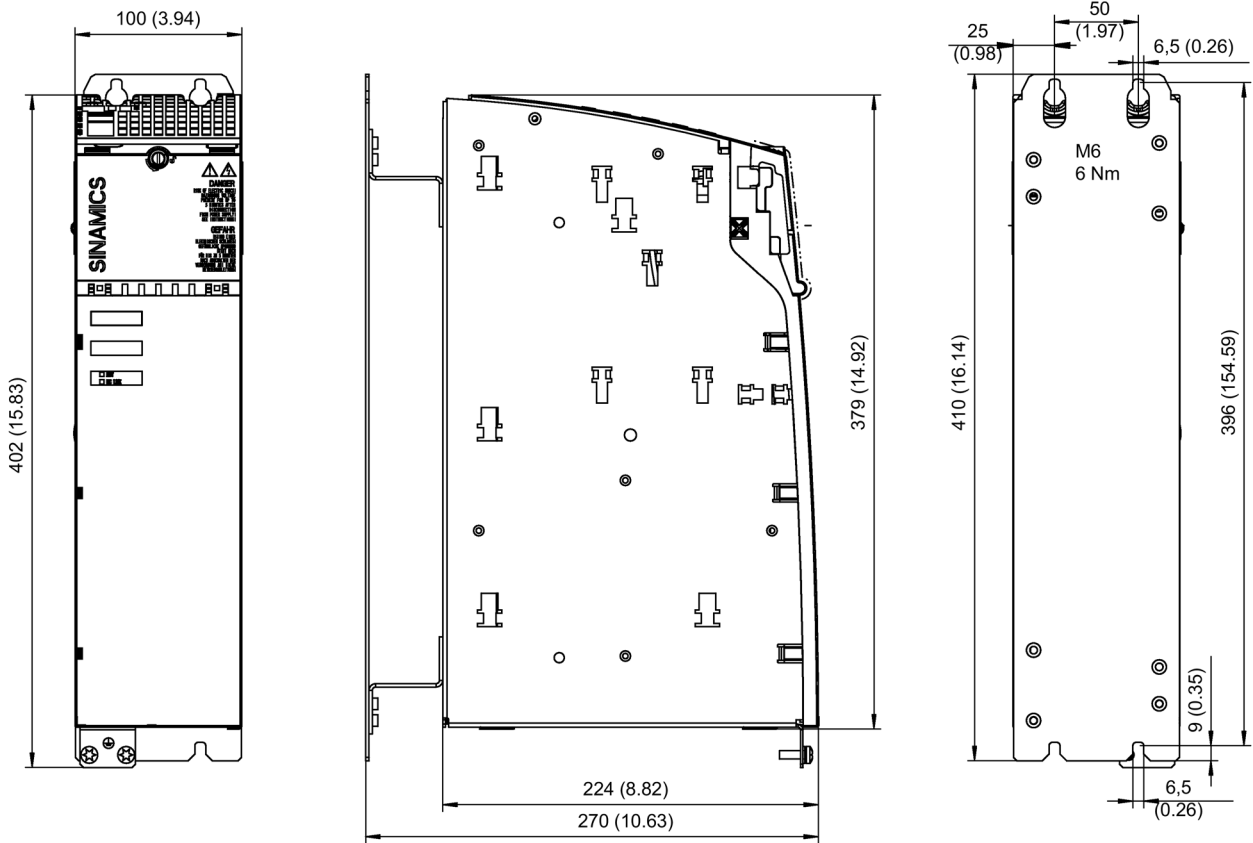
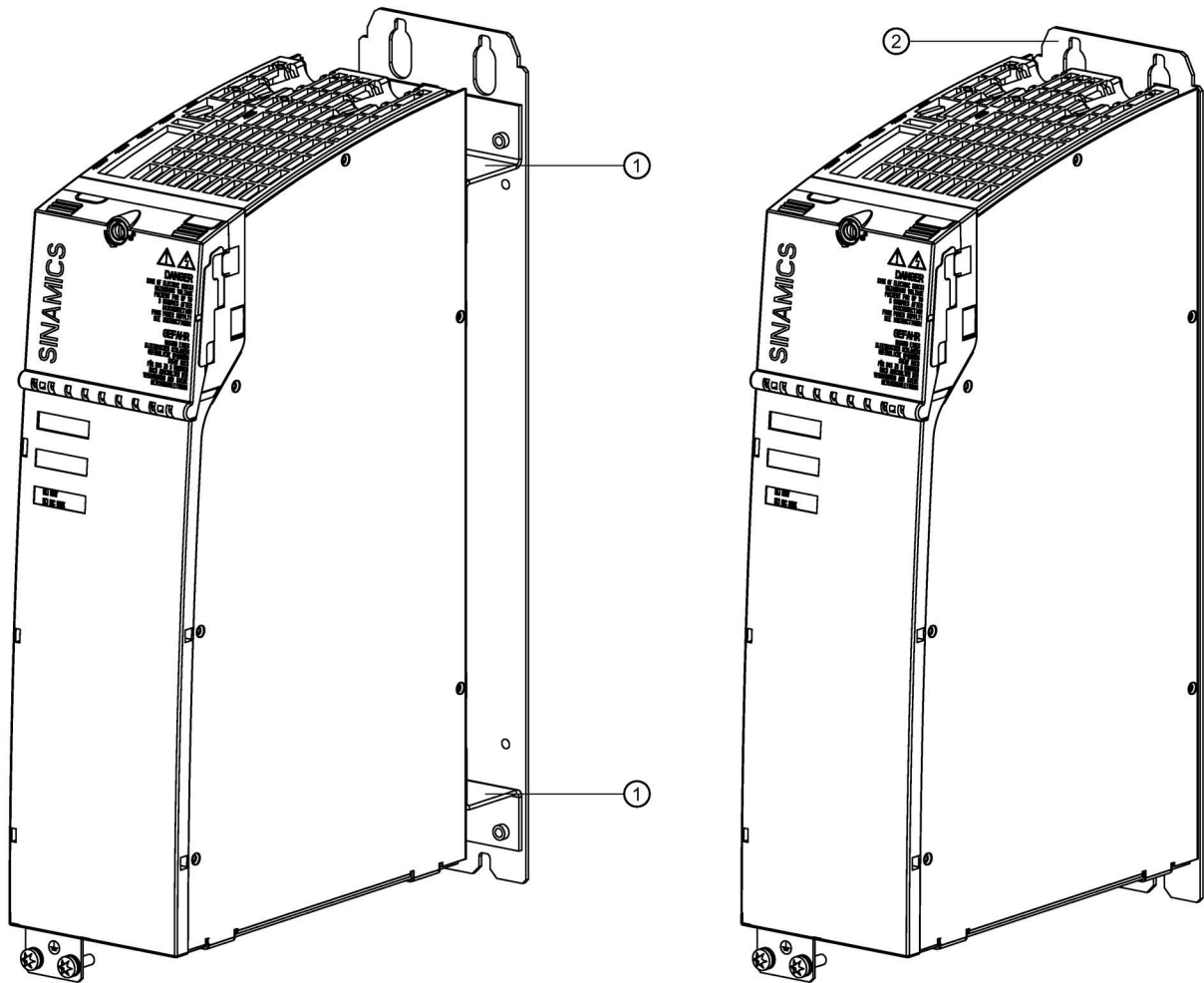

Figure 8-18 Dimension drawing of Capacitor Module, all dimensions in mm and (inches)

8.5.4 Mounting



- ① Delivered with spacer - mounting depth for drive line-up in booksize format with internal air cooling
- ② Spacer removed - mounting depth for drive line-up in booksize format with external air cooling

Figure 8-19 Mounting methods for Capacitor Module with and without spacer elements

The Capacitor Module can be attached to the cabinet panel with or without spacer elements.

8.5.5 Technical Specifications

Table 8- 21 Technical data

6SL3100-1CE14-0AA0		
DC-link voltage	V _{DC}	510 ... 720
Electronics power supply	V _{DC}	24 (20.4 ... 28.8)
Capacitance	μF	4100
Current carrying capacity		
DC link busbar	A	100
24 V busbar	A	20
Power loss (see power loss tables (Page 734))	W	25
Ventilation clearances (above/below)	mm	≥ 80
Weight	kg	7.3

8.6 Control Supply Module CSM

8.6.1 Description

The Control Supply Module provides an output voltage of 24 V - 28.8 V DC. The output voltage can be adjusted using an integrated potentiometer.

The Control Supply Module absolutely requires the AC line voltage for start-up, from which it continues to be supplied during normal operation. When the power fails, the module automatically changes over to supply from the DC link. This makes it possible, for example, to execute retraction movements in the event of a power failure. If the AC line voltage is once again within the permissible range, the equipment switches back to AC, ensuring that the DC link will only be charged if the AC is either not available or is not within the permissible range.

Note

Start-up of the Control Supply Module from the DC-link voltage is not possible to prevent an uncontrolled start-up with residual voltage at the DC link.

The Control Supply Module has safe electrical separation between the line potential and the DC link potential. This therefore ensures that the DC link is not unintentionally charged. The Control Supply Module can therefore remain connected to the supply if the Line Module is galvanically isolated from the line supply, for example using a line contactor.

The 24 V ground of the Control Supply Module is internally grounded.
The Control Supply Module is cooled using an internal fan.

Temperature and voltages are internally monitored.

Temperature monitoring:

In the event of an overtemperature in the Control Supply Module, a temperature advance warning is issued via a signaling contact. If the temperature falls below the limit value within the advance warning time, then the module remains operational and the signaling contact is de-energized. If the overtemperature condition persists, the module is switched off and restarted.

Voltage monitoring:

When the monitoring threshold (32 V) of the output voltage is exceeded for > 20 ms, the control supply module switches off and attempts a restart after 10 s. This is supplemented by a hardware-based overvoltage limiting. This prevents that more than 35 V can be output in the case of a fault.

The Control Supply Module can either be operated individually or in a parallel connection with a maximum of 10 devices. The switchover between single and parallel operation is realized in a no-current state using a DIP switch on the upper side of the module.

Note

Compatibility

The Control Supply Module 6SL3100-1DE22-0AA1 with extended functions described here replaces the Control Supply Module 6SL3100-1DE22-0AA0. The modules are downward-compatible (-0AA1 can be used as spare part for -0AA0).

8.6.2 Safety instructions for Control Supply Modules



 WARNING
Electric shock when live parts are touched when using the Control Supply Module
The Control Supply Module has 2 supply circuits. Touching live components can result in death or severe injury.
<ul style="list-style-type: none">• Switch off both supply circuits before you start any work.



 WARNING
Electric shock due to the residual charge of the DC-link capacitors
Due to the DC link capacitors, a hazardous voltage is present in the DC link for up to 5 minutes after the power supply has been switched off.
Contact with live parts can result in death or serious injury.
<ul style="list-style-type: none">• Do not open the protective cover of the DC link until 5 minutes have elapsed.• Measure the voltage before starting work on the DCP and DCN DC link terminals.



 WARNING
Electric shock when the protective cover of the DC link is open
Contact with live parts can result in death or serious injury.
<ul style="list-style-type: none">• Only operate the components with closed protective cover.



 WARNING
Electric shock due to missing DC-link side covers
Live parts are exposed if the DC link side covers are not fitted. Contact with these live parts could cause an electric shock.
<ul style="list-style-type: none">• Mount the side covers on the first and last component in the drive line-up.• Order any missing side covers (Article number: 6SL3162-5AA00-0AA0).

**! WARNING****Electric shock or fire due to missing or unsuitable overcurrent protective device**

Overcurrent protective equipment that trips too late or not all can cause electric shock or fire.

- Connect each Control Supply Module via a suitable circuit breaker or safety fuses.
- The types specified in the technical data for the respective module are to be used in this regard. For applications according to IEC, equivalent fuses and circuit breakers are permissible.
- To protect personnel and for fire protection purposes, at the infeed point, the short-circuit rating and loop impedance must match the specifications in the documentation so that the installed overcurrent protection devices trip within the specified time.

NOTICE**Damage to equipment as a result of loose power connections when using the 24 V terminal adapter**

Insufficient tightening torques or vibration can result in faulty electrical connections. This can cause fire damage or malfunctions.

- When using the 24 V terminal adapter, it must be screwed onto the Control Supply Module. Tighten the enclosed EJOT-PT K30 x 16 screw with the specified tightening torque (0.5 Nm / 4.4 lbf in).
- Check the tightening torques of all power connections at regular intervals and tighten them when required. This applies in particular after transport.

8.6.3 Interface description

8.6.3.1 Overview

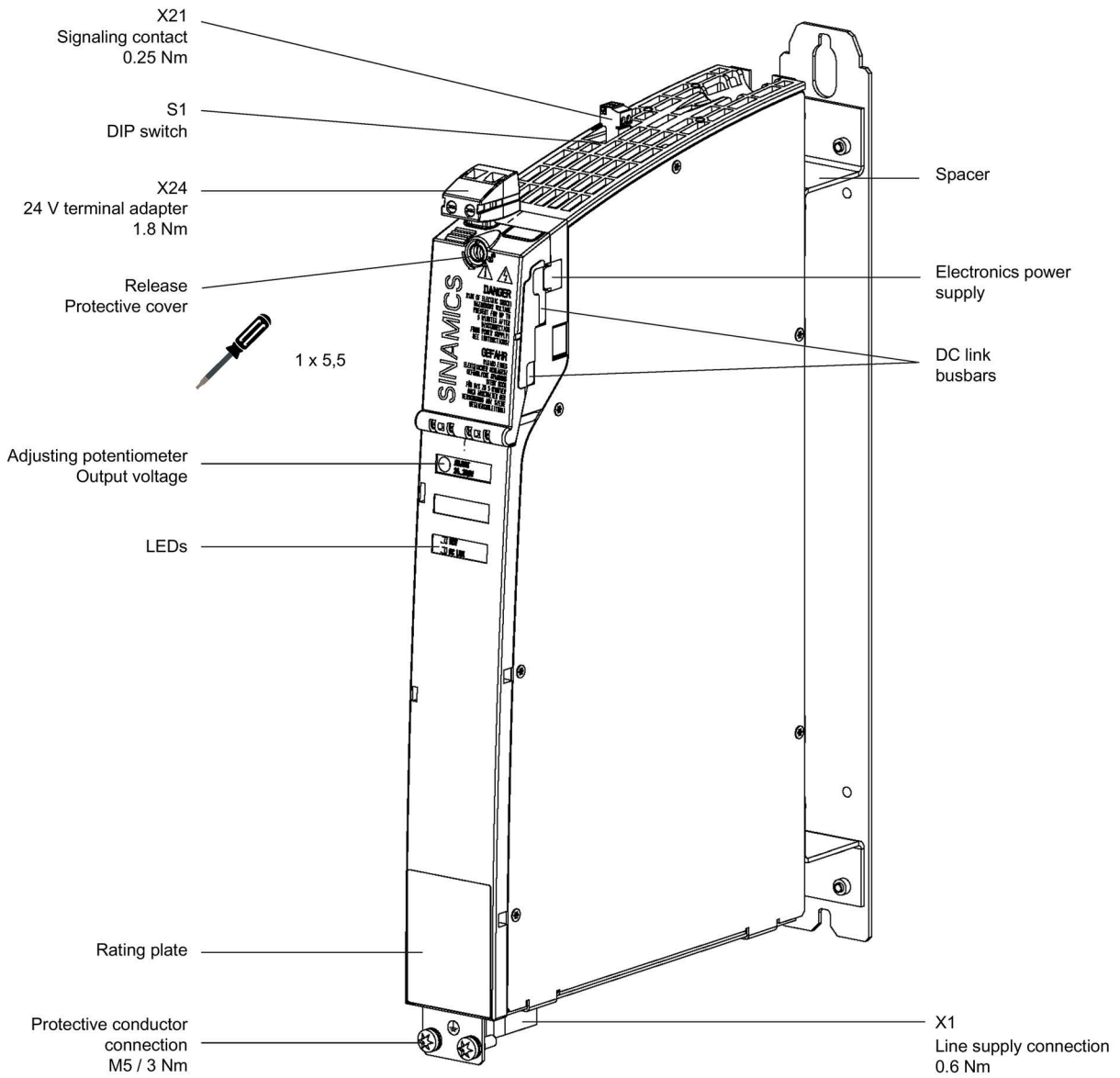
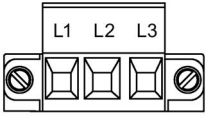
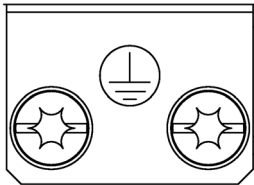

Figure 8-20 Interface overview, Control Supply Module

8.6.3.2 X1 line connection

Table 8- 22 X1 line connection

	Terminal	Technical data
	L1	Supply voltage: 3 AC 380 V ... 480 V, 50 / 60 Hz Type: Screw terminal 4 (Page 708)
	L2	
	L3	
	Protective conductor connection	Screw M5 / 3 Nm (26.6 lbf in) on enclosure

8.6.3.3 X21 signaling contact

Table 8- 23 X21 signaling contact

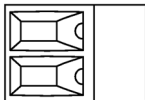
	Terminal	Technical data
	1	Voltage: 24 V DC Maximum load current: 0.5 A (ohmic load)
	2	
Type: Screw terminal 1_1 (Page 708) Max. cross-section that can be connected 1.5 mm ² (AWG 16)		

The 2-pole terminal connector for the signaling contact is included in the Completion Kit provided.

The signaling contact can be connected with a digital input (DI) on the Control Unit or other digital interface (PLC, SCADA). In parallel or redundant operation the failure of a Control Supply Module is indicated in order to initiate a service call, for example.

The signaling contact operates as an isolated NO contact. The contact is closed ("OK") if the Control Supply Module is operating without fault. For a module output voltage that deviates from the specification, or an overtemperature condition, then the contact opens ("not OK"). The Control Supply Module is shutdown if an overtemperature condition remains after this warning.

Table 8- 24 Installing the signaling contact

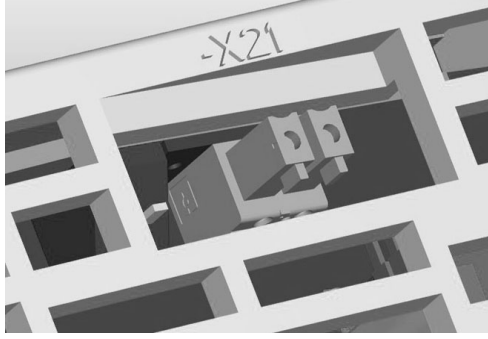
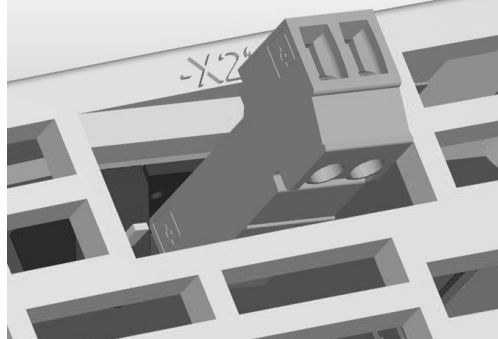
	
<p>Signaling contact without terminal connector in the delivery condition</p>	<p>Signaling contact, complete with terminal connector</p>

8.6.3.4 X24 24 V terminal adapter

Table 8- 25 X24 24 V terminal adapter

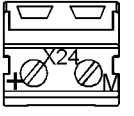
	Terminal	Designation	Technical data
	+	24 V power supply	Supply voltage 24 ... 28.8 V DC
	M	Ground	Electronics ground
<p>Type: Screw terminal 5 (Page 708)</p>			

The 24 V terminal adapter is included in the scope of supply.

8.6.3.5 S1 DIP switch

Table 8- 26 DIP switch S1

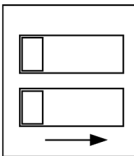
	Terminal	Designation	Technical data
	1	Changeover switch, single operation / parallel operation	Left: Single operation Right: Parallel operation
	2	Dummy contact (not used)	Changing over the output characteristic

It is only permissible to changeover when in the no-voltage state.

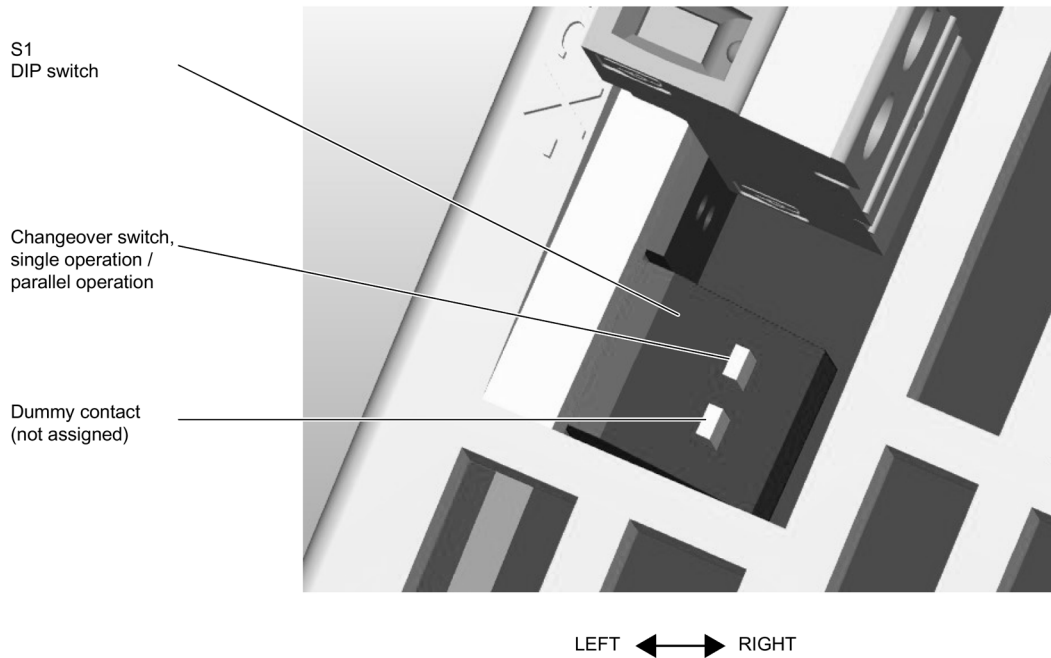

Figure 8-21 DIP switch on the upper side of the component

When delivered, "single operation" is set. Both switches are set to the left.

8.6.4 Connection examples

The Control Supply Module is connected to the line supply (3-ph. 380 V AC -10 % to 480 V AC +10 %) via interface X1 (screw terminals 0.2 to 4 mm²).

Note

Each Control Supply Module is to be connected via a suitable circuit breaker, or alternatively a safety fuse.

The types specified in the "Technical data (Page 526)" for the respective module are to be used in this regard. For applications according to IEC, equivalent fuses and circuit breakers are permissible.

The Control Supply Module has an internal line filter (Class A for TN systems), and the pre-charging circuit for the DC link inside the device is electrically isolated from the 24 V supply.

The Control Supply Module also features a current limitation function.

Note

If you use cables with a cross-section of 2.5 mm², no additional protection is required on the 24 V side for the following cable types:

- Cables of the XLPE type
 - Cables of the EPR type
 - Cable with a similar properties and which is thermally stable up to 90 °C
-

Note

Observe the connection sequence

If a selectively tripping, AC/DC-sensitive RCCB is used for the drive line-up, the Control Supply Module must always be connected to the line supply downstream of this circuit breaker. Otherwise, the residual current operated circuit breaker will trip erroneously if the direct-current component is asymmetrically drawn in certain operating states.

8.6.4.1 Single operation

Within the drive line-up, the Control Supply Module must be connected to the drive line-up via the DC link busbars as well as the 24 V busbars. The 24 V connector from the accessories pack must always be inserted. The DIP switch on the Control supply Module must be set to "single mode" The connection can be established as shown below.

The supply for other 24 V loads outside the drive line-up using additional Control Supply Modules, whose outputs are not connected in parallel, must be realized using the 24 V terminal adapter (do not insert the 24 V connector).

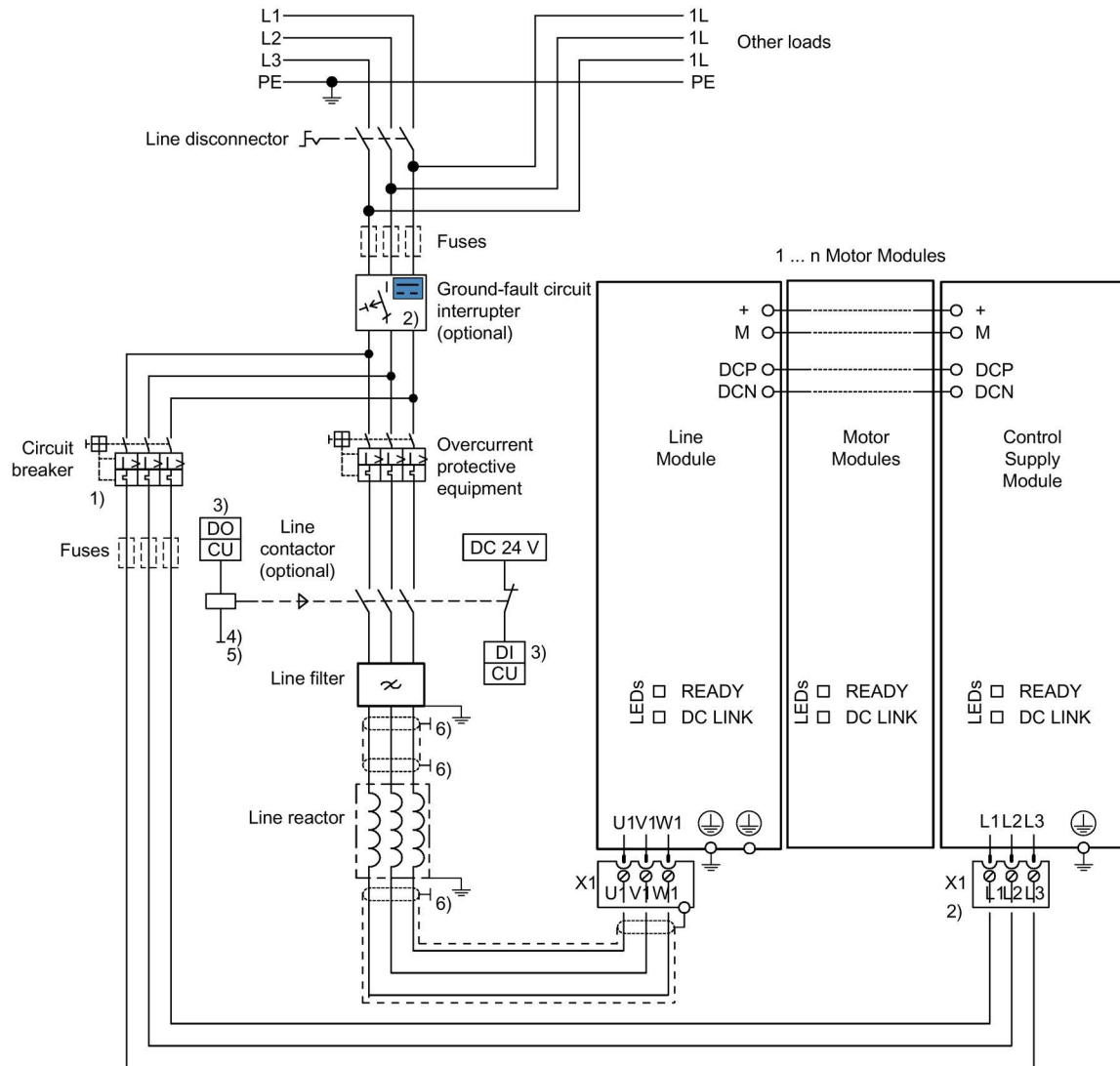

- 1) Permissible types, see "Technical data"
- 2) The line connection must always be available.
- 3) DI/DO, controlled from the Control Unit
- 4) No additional load/consumer is permitted after the line contactor
- 5) The current carrying capacity of the DO should be taken into account; it may be necessary to use an output interface relay.
- 6) Contact established through the rear mounting panel or shield rails in accordance with the EMC installation guideline

Figure 8-22 Connection example for Control Supply Module in single operation

8.6.4.2 Parallel operation

A maximum of 10 Control Supply Modules can be connected in parallel.

The DIP switch of the Control supply Module must be set to "parallel mode". The same output voltage must be set for all modules at the potentiometer.

In the parallel mode, each Control Supply Module should supply the 24 V DC voltage via the 24 V terminal adapter. This is the reason that the 24 V connector must **not** be used (see connection examples).

For a parallel connection we recommend that a SITOP redundancy module (6EP1961-3BA20) is used. One SITOP redundancy module must be used for two Control Supply Modules in this case. Alternatively, a connection with external diodes to decouple the individual Control Supply Modules is possible. If a Control Supply Module fails, an alarm is generated and provided via the X21 signaling contact. The 24 V supply is maintained via the second module.

Note

Parallel connection

Only Control Supply Modules with article number 6SL3100-1DE22-0AA1 may be used for parallel connection.

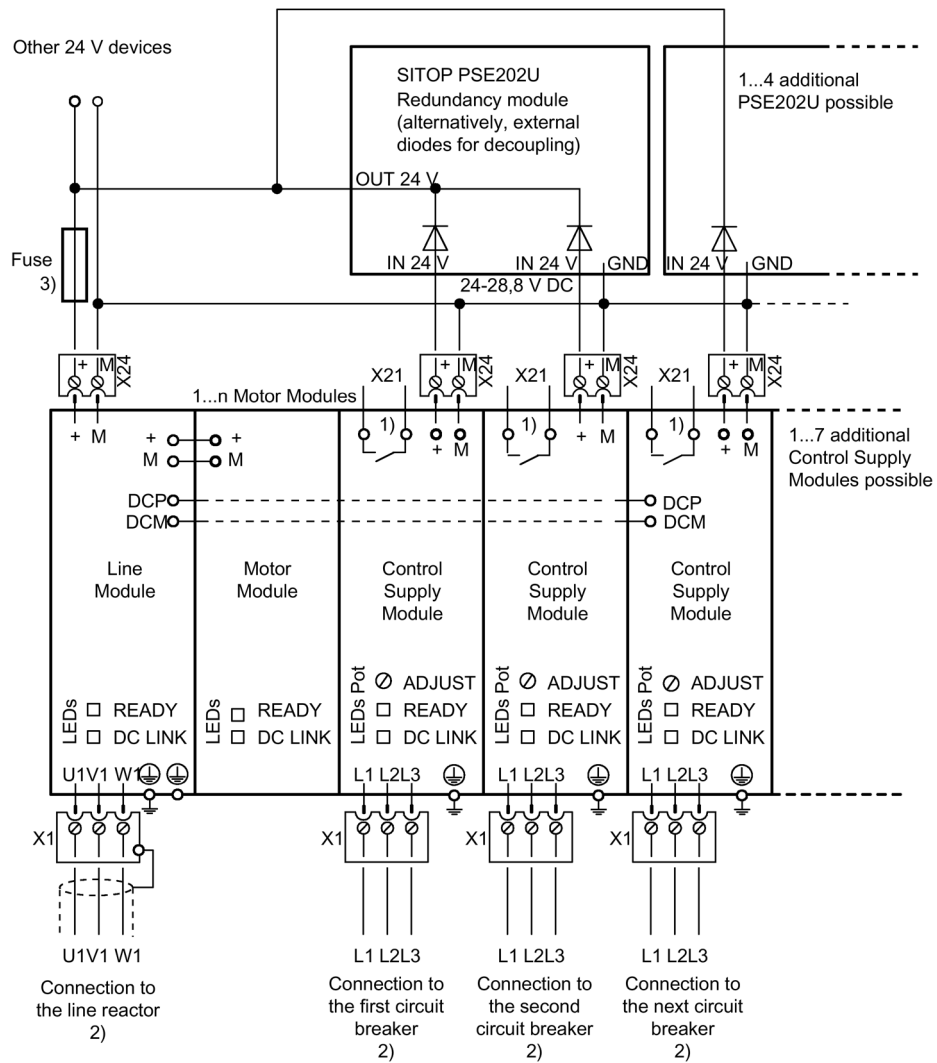

- 1) Connection to digital interface (SCADA or PLC); closed means: 24 V OK
- 2) Continue as in "Connection example for Control Supply Module in single operation"
- 3) Max. permissible 20 A continuous current (refer to the fuse characteristics)

Figure 8-23 Connection example for parallel connection of 2 to 10 Control Supply Modules via a SITOP PSE202U redundancy module

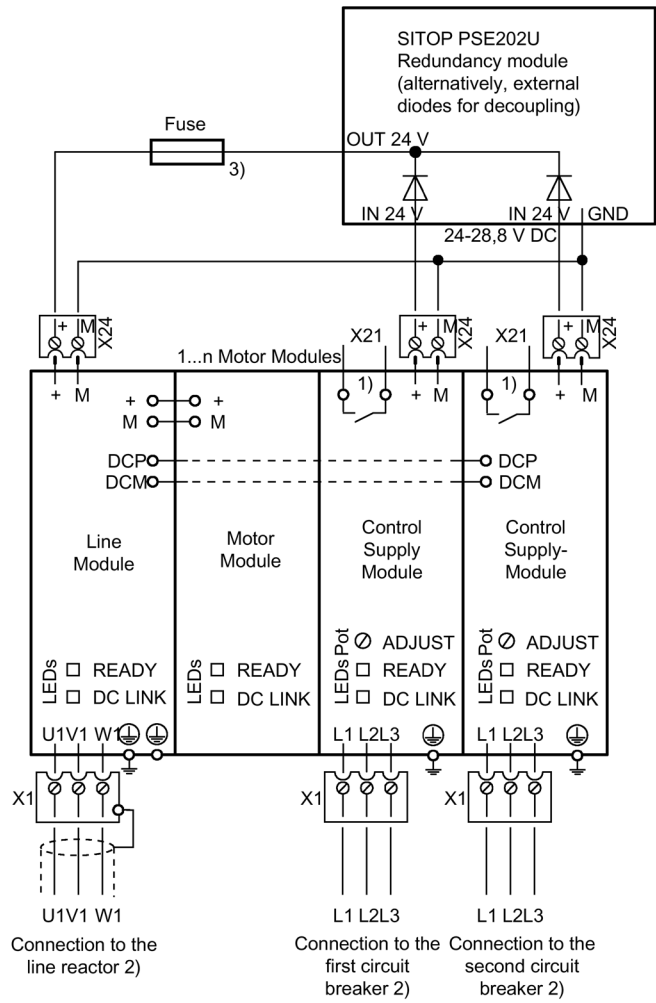

- 1) Connection to digital interface (SCADA or PLC); closed means: 24 V OK
- 2) Continue as in "Connection example for Control Supply Module in single operation"
- 3) Max. permissible 20 A continuous current (refer to the fuse characteristics)

Figure 8-24 Connection example for a redundancy circuit with 2 Control Supply Modules via a SITOP PSE202U redundancy module

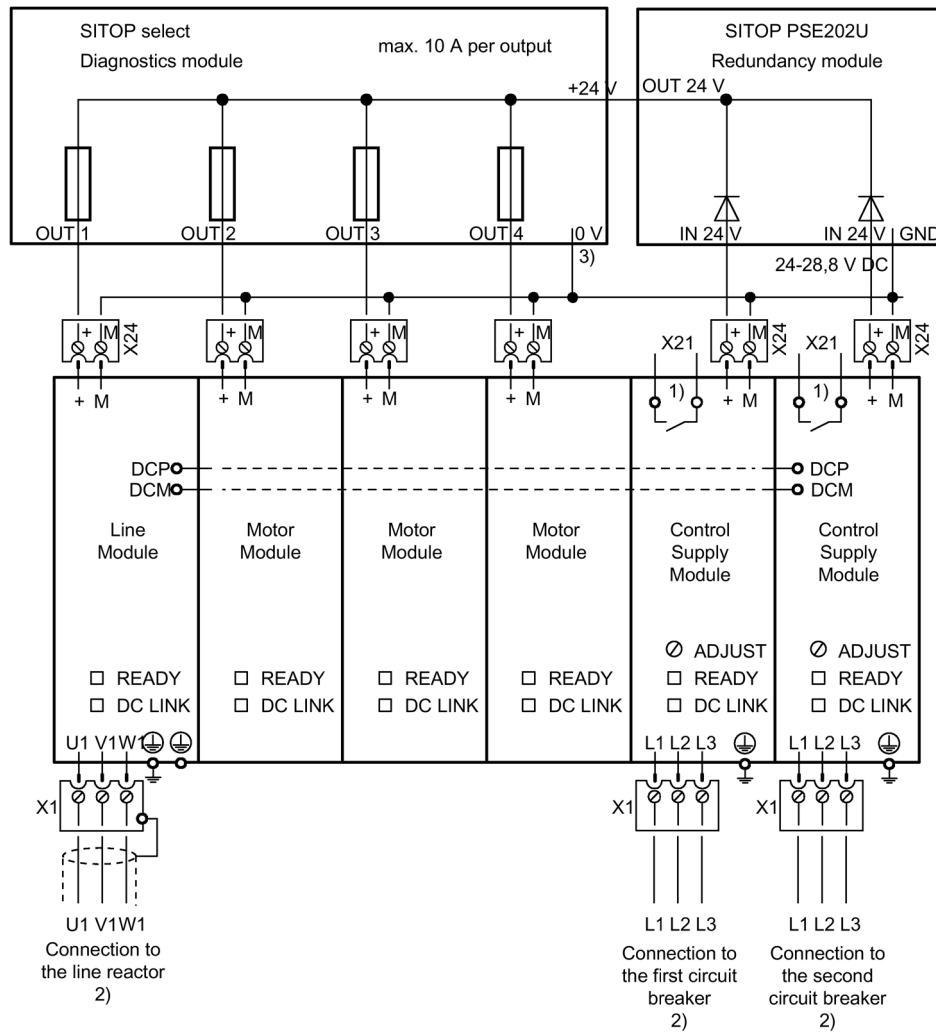

- 1* Connection to digital interface (SCADA or PLC); closed means: 24 V OK
- 2* Continue as in "Connection example for Control Supply Module in single operation"
- 3* Functional reference point (not capable of a high current load)

Figure 8-25 Connection example for parallel connection of Control Supply Modules via a SITOP PSE202U redundancy module and a SITOP select diagnostic module (6EP1961-2BA00)

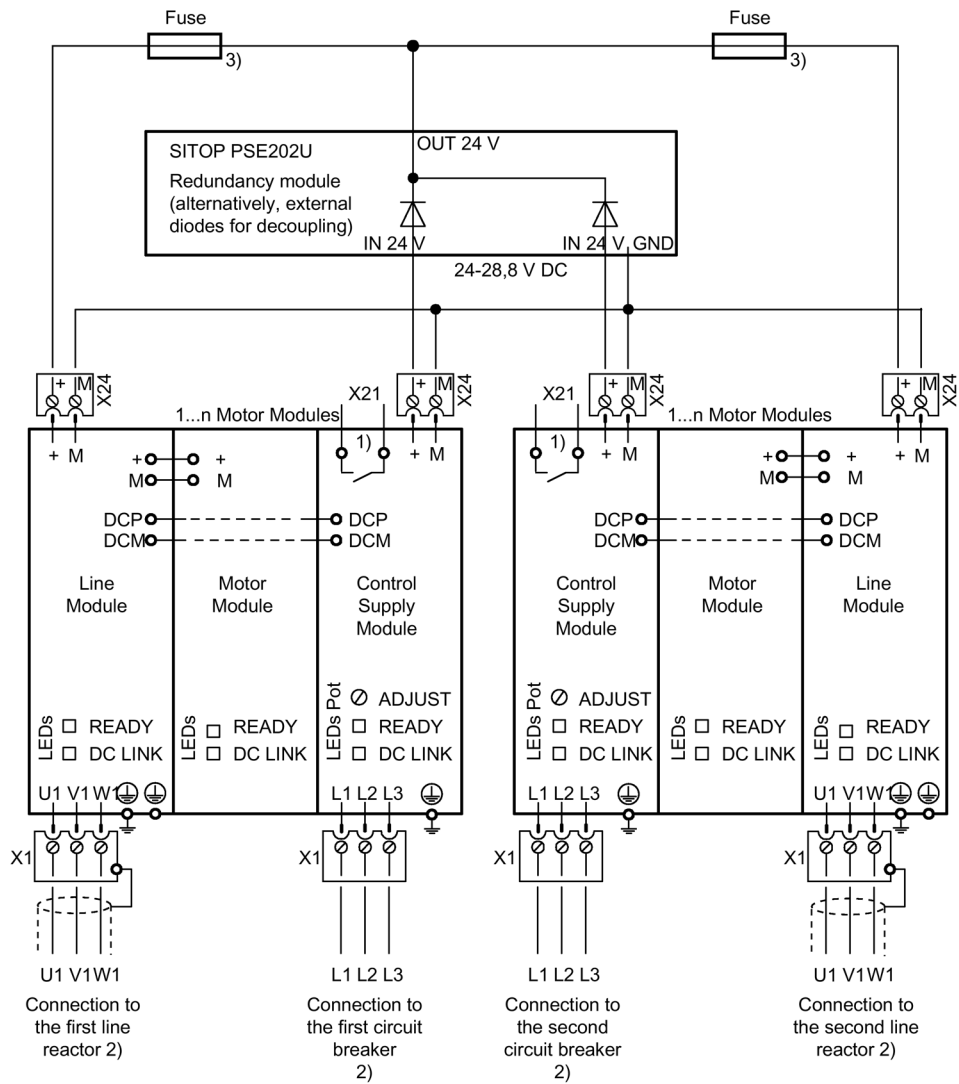

- 1) Connection to digital interface (SCADA or PLC); closed means: 24 V OK
- 2) Continue as in "Connection example for Control Supply Module in single operation"
- 3) Max. permissible 20 A continuous current (refer to the fuse characteristics)

Figure 8-26 Connection example for operation of 2 units with Control Supply Modules via a SITOP PSE202U redundancy module

8.6.5 Meaning of LEDs

Table 8- 27 Meaning of the LEDs on the Control Supply Module

LED	Color	Status	Description
READY	-	Off	The electronics power supply is outside the permissible tolerance range or the temperature prewarning is active.
	Green	Continuous light	Ready The output voltage is in the tolerance range and the temperature prewarning is inactive.
DC LINK	-	Off	DC input voltage $U_{E\ DC} < 280 \dots 300\ V$ Buffer operation is not possible.
	Orange	Continuous light	DC input voltage in the range $360 \dots 380\ V < U_{E\ DC} < 820\ V \pm 3\ \%$ Buffer operation is possible
	Red	Continuous light	DC input voltage outside the tolerance range: $U_{E\ DC} < 360 \dots 380\ V$ or $V_{E\ DC} > 820\ V \pm 3\ \%$

8.6.6 Dimension drawing

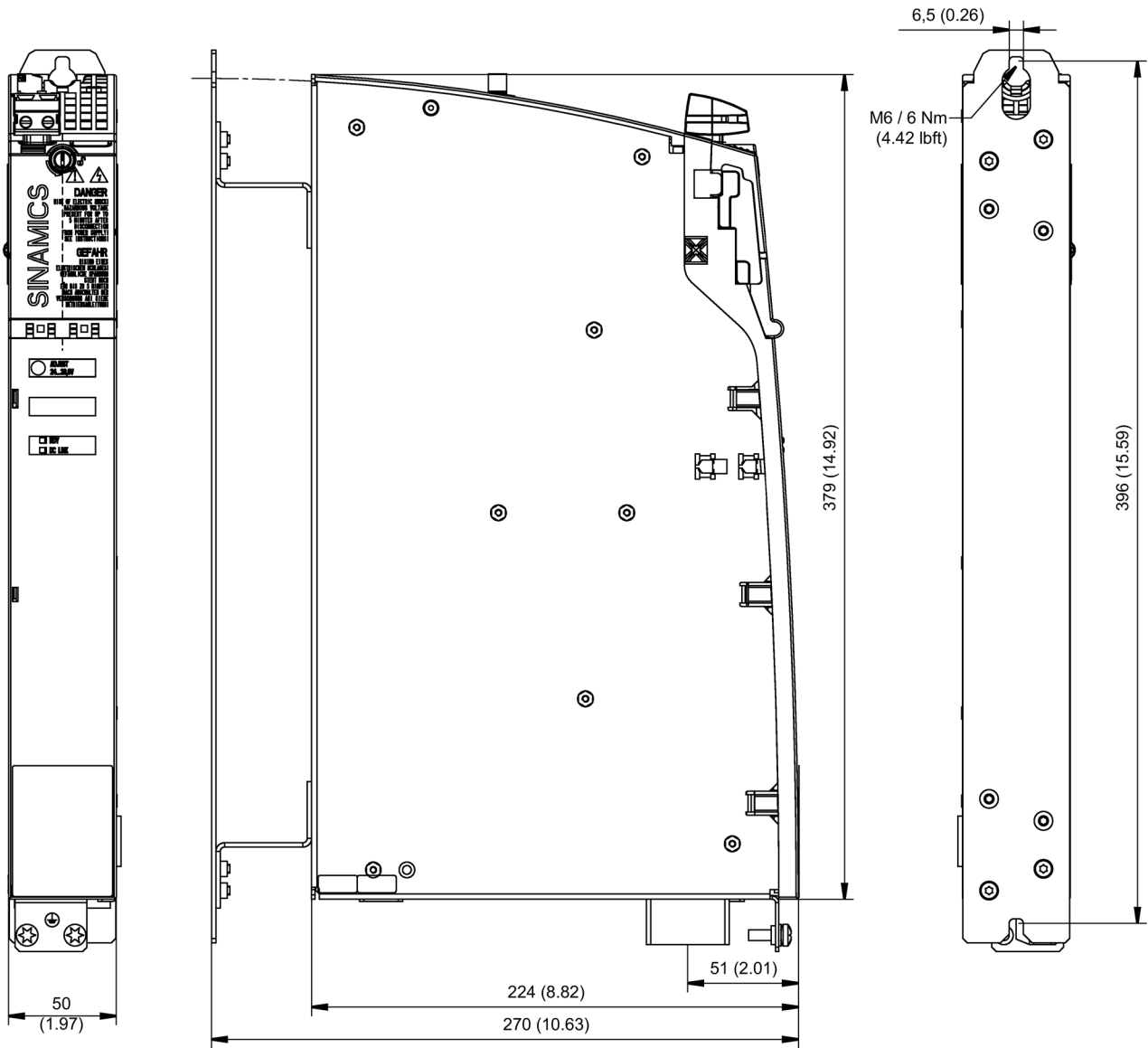
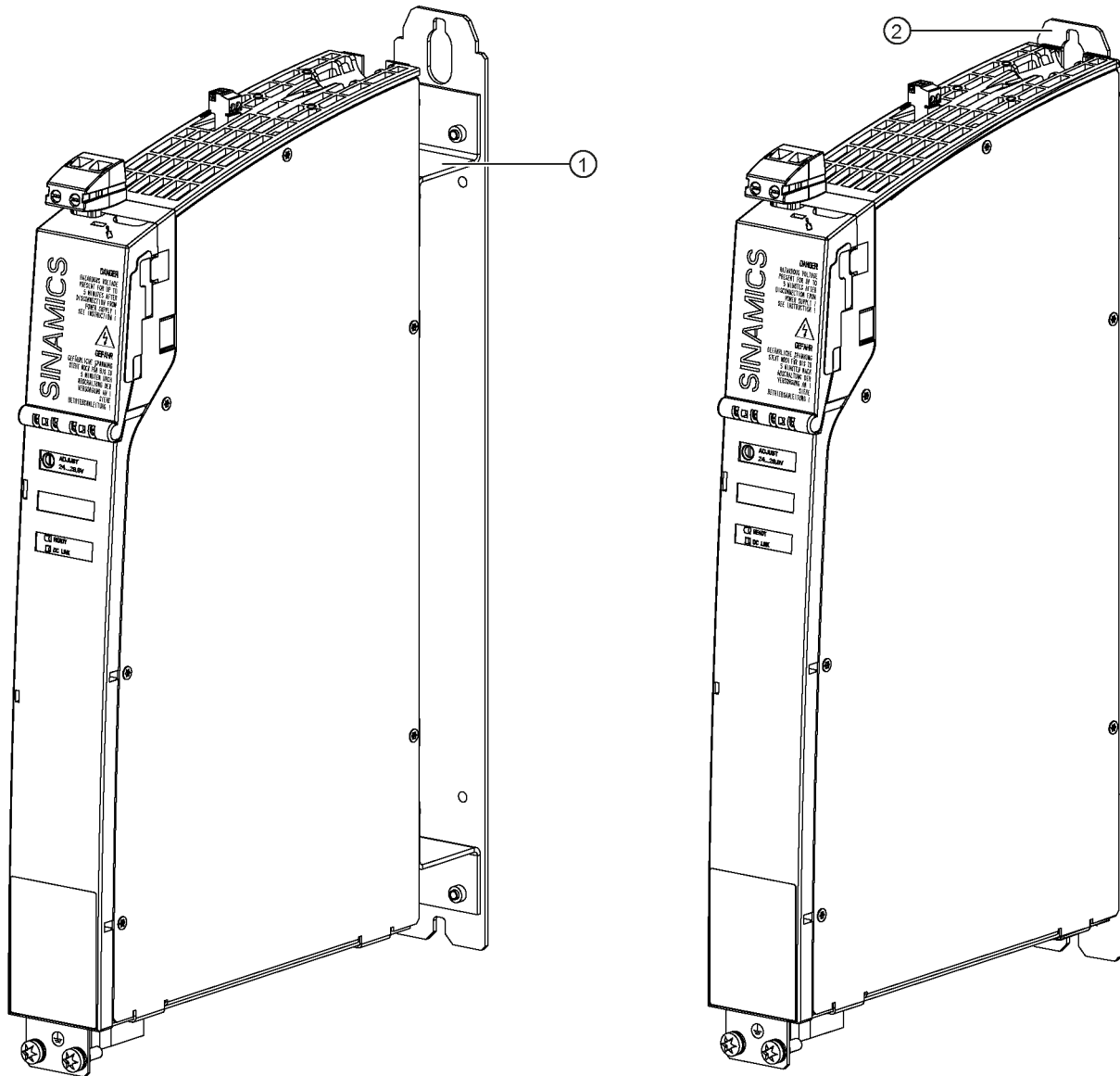

Figure 8-27 Dimension Control Supply Module, all dimensions in mm and (inches)

8.6.7 Installation



- ① Delivered with spacer - mounting depth for drive line-up in booksize format with internal air cooling
- ② Spacer removed - mounting depth for drive line-up in booksize format with external air cooling

Figure 8-28 Methods of installing the Control Supply Module with and without spacer

The Control Supply Module can be attached to the control cabinet panel with or without spacers.

8.6.8 Technical data

Table 8- 28 Technical data

6SL3100-1DE22-0AA1	Unit	Value
Input data, AC input		
Line voltage	V _{AC}	3 AC 380 ... 480 ± 15 %
Line frequency	Hz	45 ... 66
Rated input current Rated value (at V _{E rated})	A _{AC}	≤ 2
Starting current inrush	A _{AC}	≤ 28 at > 5 ms
Input data, DC input		
Rated input voltage	V _{DC}	600
Input voltage range	V _{DC}	300 ... 882
DC link voltage (continuous input voltage)	V _{DC}	430 ... 800 300 ... 430 < 1 min 800 ... 853 < 1 min 853 ... 882 < 10 s
Supply current (at 600 V)	A _{DC}	1.1
Overvoltage tripping	V _{DC}	> 882
Undervoltage tripping	V _{DC}	280 ± 3 %
Output data		
Rated output voltage V _{A rated}	V _{DC}	24 ... 28.8
Rated output current I _{A rated} ¹⁾	A _{DC}	20
Rated output power P _{A rated}	W	520
Overcurrent limitation for short-circuit	A _{DC}	approx. 23
Surge suppression	V	< 35
Current carrying capacity of the 24 V busbar	A _{DC}	20
Residual ripple (clock frequency approx. 50 kHz)	mV _{pp}	< 100
Switching peaks (bandwidth 20 MHz)	mV _{pp}	< 200
Power loss ride-through (at 400 V AC)	ms	5
Power loss		
Line	W	70
DC link	W	65
Efficiency		
%		
> 83		
circuit breaker (UL)²⁾		
Type designation:		listed NKJH: 3RV1021-1DA10 3RV2011-1DA.. 3RV2021-1DA.. 2.2 ... 3.2 (set value 3.2)
Rated current:	A	listed DIVQ: 3RV2711-4AD.. 15
Fuses (UL)²⁾		
Class RK1, J, CC, CF		
Rated current:	A	6
Operating voltage:	V _{AC}	≥ 480
Cooling method		
Internal air cooling		

6SL3100-1DE22-0AA1	Unit	Value
Ventilation clearances, above/below	mm	≥ 80
Weight	kg	4.8

- 1) Above 40° C, a linear derating of the output current above a 26 V output voltage and higher must be observed
- 2) When using circuit breakers for protection, UL approval is only possible in TN/TT line systems with grounded neutral point. Conventional fuses are required for UL approval in line supplies with grounded line conductor. The specified circuit breakers are approved for UL and IEC. For applications according to IEC, equivalent circuit breakers and fuses are permissible. The specified Class fuses are not approved for IEC.

8.6.8.1 Characteristics

Derating characteristic

For ambient temperatures > 40 °C, a linear derating for the output current must be observed as of 26 output voltage.

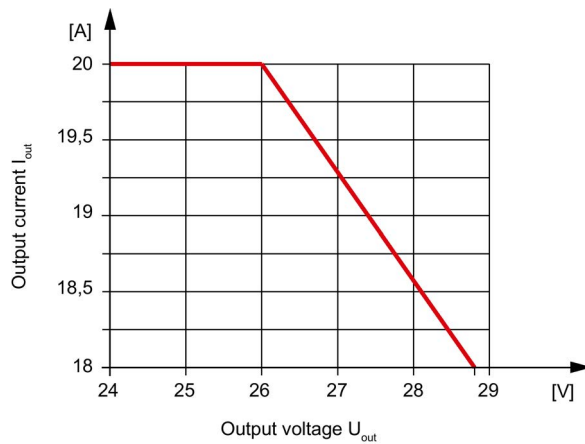

Figure 8-29 Current derating for ambient temperatures >40 °C as a function of the output voltage

Braking resistors

9.1 Description

A braking resistor is used to dissipate the excess DC link energy in generator operation. The braking resistors can be connected to a Braking Module or directly to a 20 kW or 40 kW Basic Line Module.

Resistors with and without a thermostatic switch are available with various rated powers. The thermostatic switch monitors the braking resistors for overtemperature and issues a signal at an isolated contact if the limit value is exceeded.

Table 9- 1 Assignment of braking resistors

Braking resistor	Braking Module Booksize	Braking Module Booksize Compact	Basic Line Module 20 kW	Basic Line Module 40 kW
Braking resistors without a thermostatic switch				
6SN1113-1AA00-0DA0 Resistance: 17 Ω P _N : 0.3 kW	X	X	-	-
6SL3100-1BE31-0AA0 Resistance: 5.7 Ω P _N : 1.5 kW	X	X	-	-
Braking resistors with a thermostatic switch				
6SE7018-0ES87-2DC0 Resistance: 80 Ω P _N : 1.25 kW	-	X	X	X
6SE7021-6ES87-2DC0 Resistance: 40 Ω P _N : 2.5 kW	-	X	X	X
6SE7023-2ES87-2DC0 Resistance: 20 Ω P _N : 5 kW	-	X	X	X
6SE7028-0ES87-2DC0 Resistance: 8 Ω P _N : 12.5 kW	-	-	-	X

Installation

The braking resistors can be installed standing on the floor of the control cabinet or suspended. You must ensure that the braking resistors do not obstruct the flow of cooling air to the drive line-up.

Positioning the braking resistor outside the control cabinet or switchgear room enables the resulting thermal losses to be routed away. This reduces the level of air conditioning required.

Connection cables

A shielded connecting cable (3 m, 3 x 1.5 mm²) is supplied with braking resistor 6SN1113-1AA00-0DA0.

All other braking resistors are supplied without a connection cable. The maximum conductor cross-sections are listed in the technical data.

The maximum cable length for all braking resistors is 10 m.

9.2 Safety instructions for braking resistors

 WARNING
Fire due to ground fault / short-circuit Inadequate installation of the cables to the braking resistor can result in a ground fault/short-circuit and place persons at risk as a result of the associated smoke and fire. <ul style="list-style-type: none">• Use the local installation regulations to avoid this fault.• Protect the cables against mechanical damage.• Also implement one of the following measures:<ul style="list-style-type: none">– Use cables with double insulation.– Maintain adequate clearance, e.g. by using spacers.– Lay the cables in separate cable ducts or conduits.



 CAUTION
Burns due to high surface temperatures The braking resistor can become very hot. You can get seriously burnt when touching the surface. <ul style="list-style-type: none">• Mount the braking resistors so that contact is not possible. If this is not possible, attach a clearly visible and understandable warning notice at hazardous positions.

9.3 Dimension drawings and installation

Braking resistors without a thermostatic switch

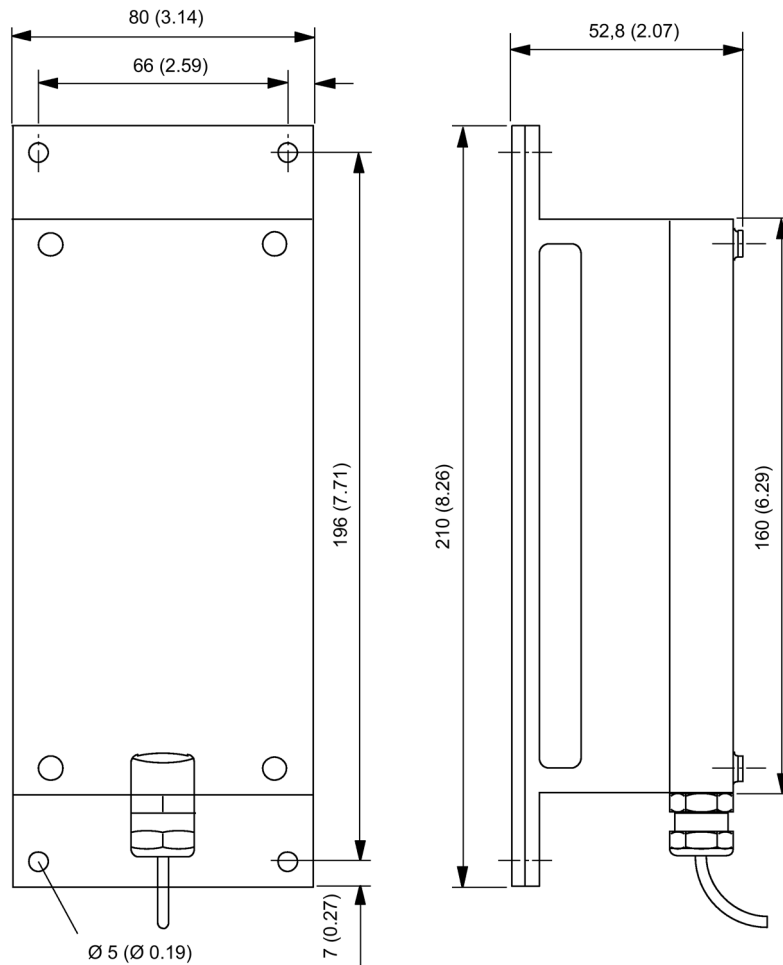

Figure 9-1 Dimension drawing of braking resistor 6SN1113-1AA00-0DA0 where $P_n/P_{max} = 0.3 \text{ kW}/25 \text{ kW}$, all dimensions in mm and (inches)

9.3 Dimension drawings and installation

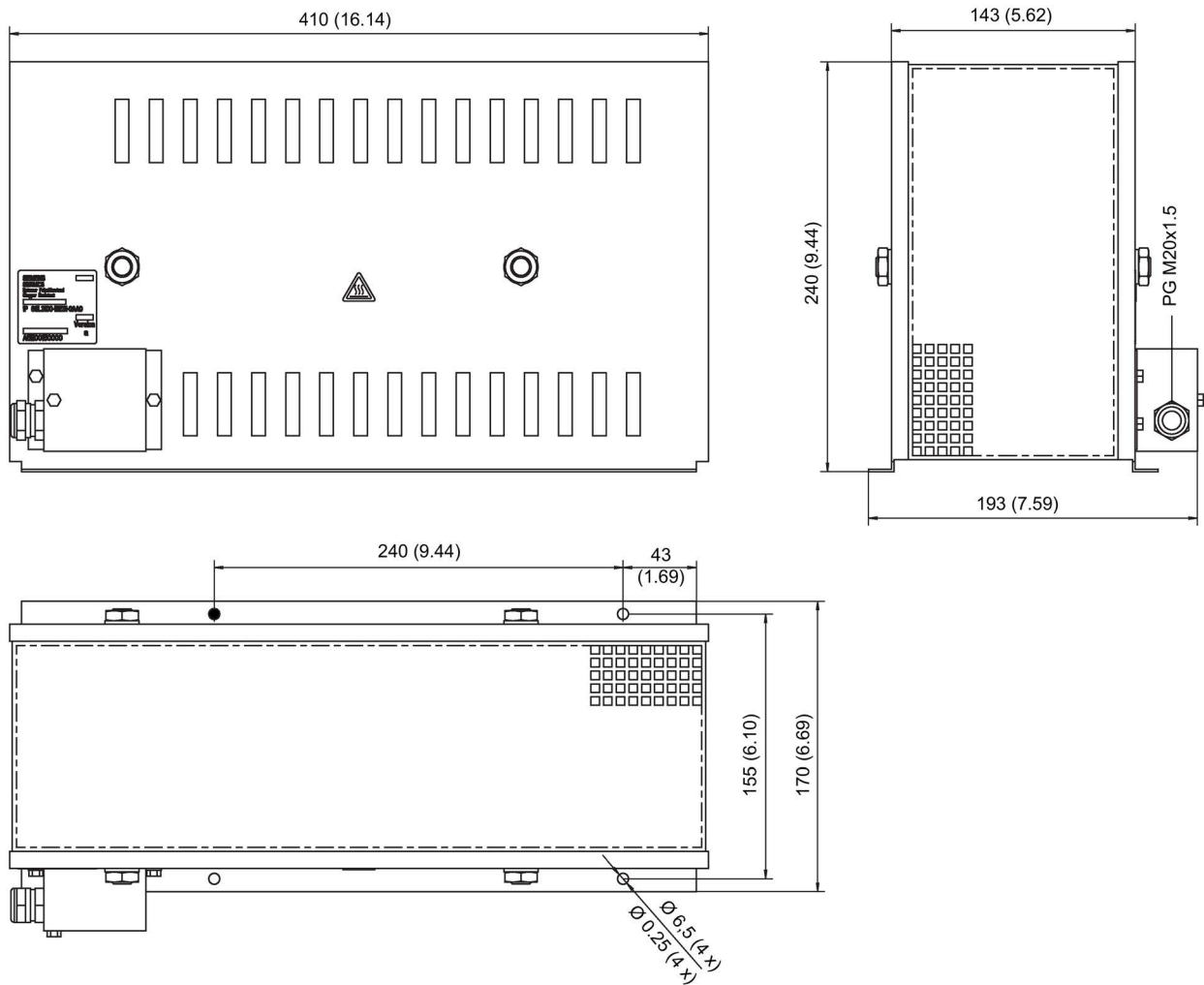

Figure 9-2 Dimension drawing of braking resistor 6SL3100-1BE31-0AA0 where $P_n/P_{max} = 1.5 \text{ kW}/100 \text{ kW}$, all dimensions in mm and (inches)

Braking resistors with a thermostatic switch

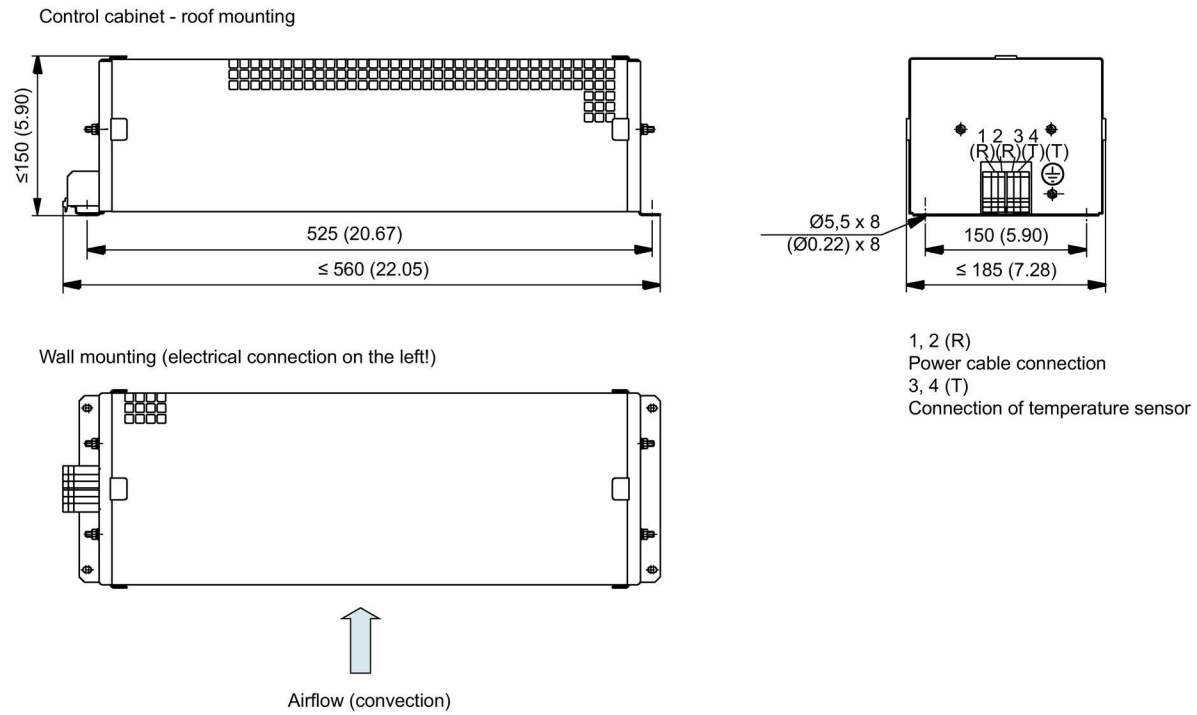

Figure 9-3 Dimension and installation drawing (roof and wall mounting) of braking resistor 6SE7018-0ES87-2DC0 where $P_n/P_{max} = 1.25 \text{ kW}/7.5 \text{ kW}$, all dimensions in mm and (inches)

9.3 Dimension drawings and installation

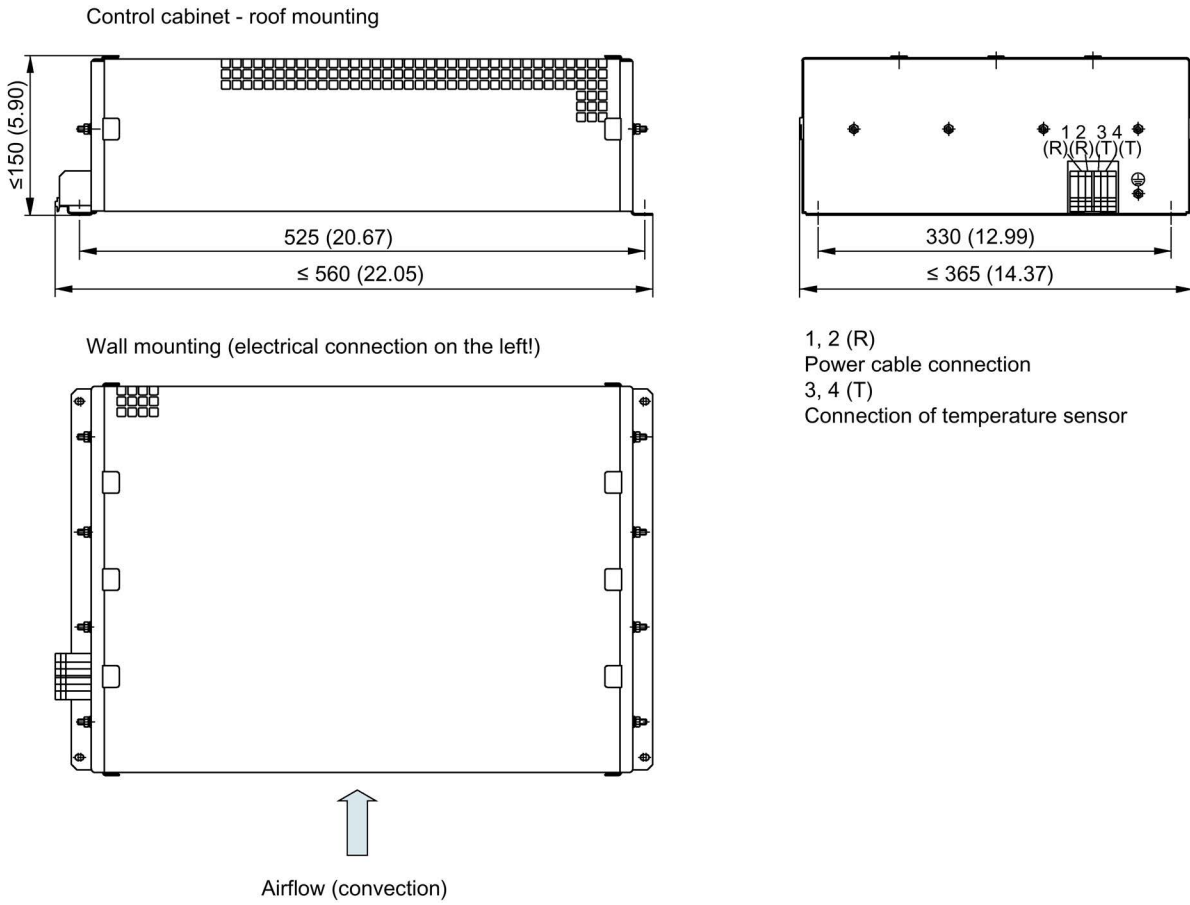
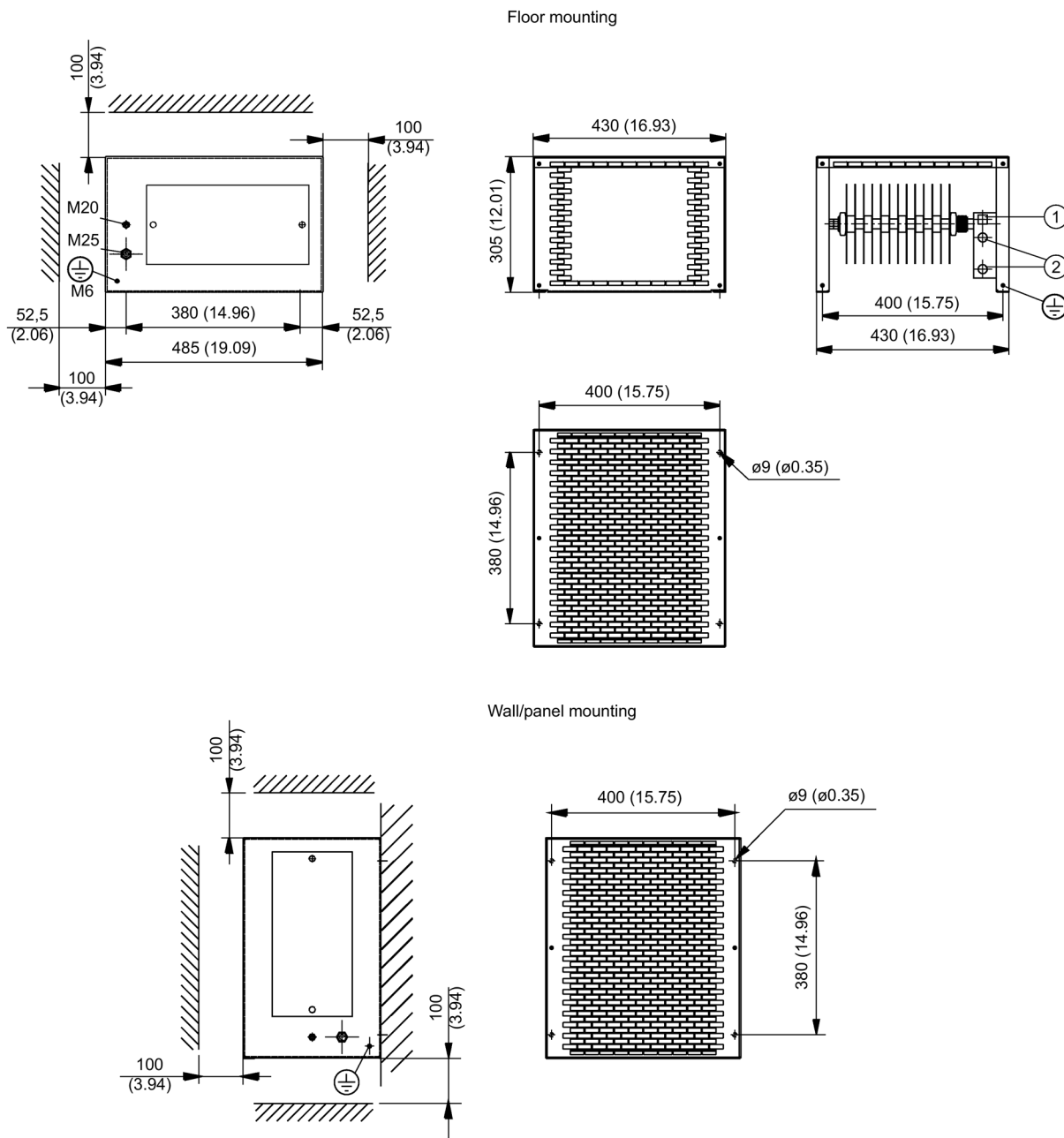
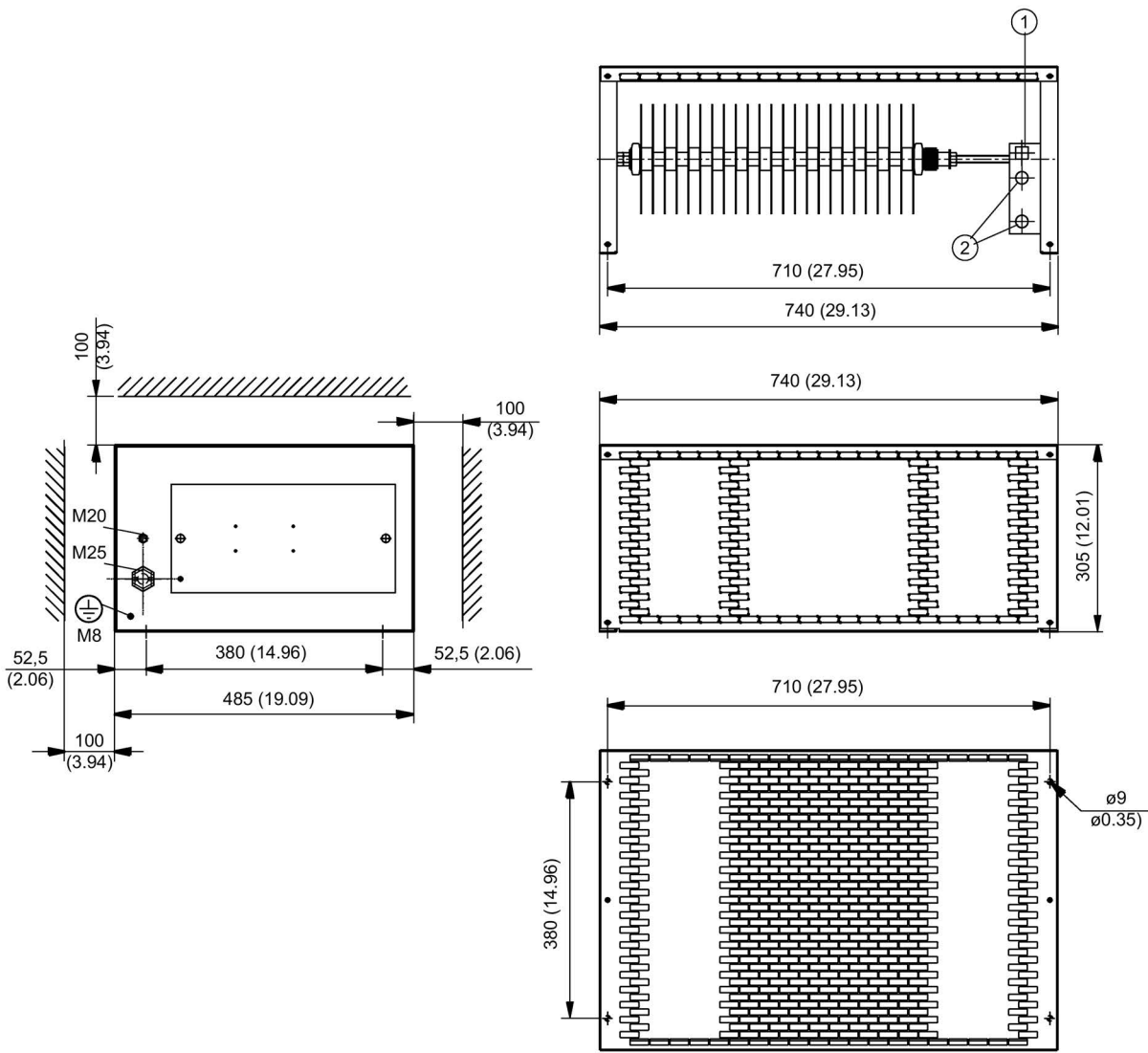

Figure 9-4 Dimension and installation drawing (roof and wall mounting) of braking resistor 6SE7021-6ES87-2DC0 where $P_n/P_{max} = 2.5 \text{ kW}/15 \text{ kW}$, all dimensions in mm and (inches)



- ① Connection for thermostatic switch T1/T2 with conductor cross-section 2.5 mm²
- ② Connection for power cable, 2 x M6 bolts

Figure 9-5 Dimension and installation drawing (floor and wall mounting) of braking resistor 6SE7023-2ES87-2DC0 where $P_n/P_{max} = 5 \text{ kW}/30 \text{ kW}$, all dimensions in mm and (inches)



- ① Connection for thermostatic switch T1/T2 with conductor cross-section 2.5 mm²
- ② Connection for power cable, 2 x M6 bolts

Figure 9-6 Dimension and installation drawing (floor mounting) of braking resistor 6SE7028-0ES87-2DC0 where $P_n/P_{max} = 12.5 \text{ kW}/75 \text{ kW}$, all dimensions in mm and (inches)

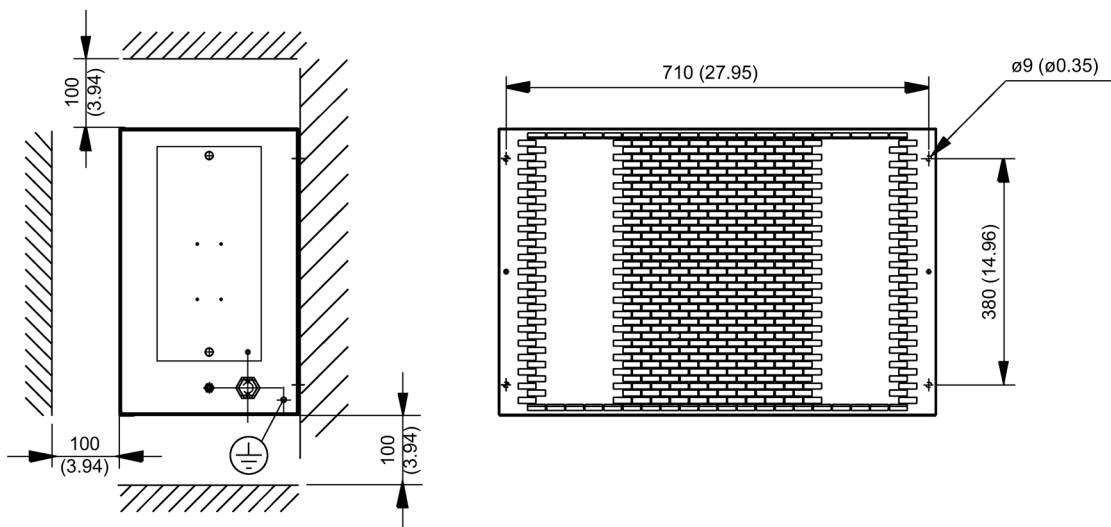

Figure 9-7 Installation drawing (wall mounting) of braking resistor 6SE7028-0ES87-2DC0 where $P_n/P_{max} = 12.5 \text{ kW}/75 \text{ kW}$, all dimensions in mm and (inches)

9.4 Technical data

Table 9-2 Technical data for braking resistors without a thermostatic switch

	Unit	6SN1113-1AA00-0DA0	6SL3100-1BE31-0AA.
Resistance R	Ω	17	5.7
Rated power P_N	kW	0.3	1.5
Peak power P_{max}	kW	25	100
Max. energy consumption E_{max}	kWs	7.5	200
Power cable connection		Included in scope of delivery; length 3 m, 3 x 1.5 mm ² (3 x AWG 16)	Screw terminal ¹⁾ , 4 mm ² (AWG 12)
Ventilation clearances (all around)	mm	≥ 100	
Weight	kg	3.4	5.6
Dimensions (W x H x D)	mm	80 x 210 x 53	193 x 410 x 240
Degree of protection to IEC 60529		IP54	IP20
Approvals		cULus	---

¹⁾ Recommended connection cross-section: 4 mm² (AWG 12)

Table 9- 3 Technical data for braking resistors with a thermostatic switch

	Unit	6SE7018-0ES87-2DC0	6SE7021-6ES87-2DC0	6SE7023-2ES87-2DC0	6SE7028-0ES87-2DC0
Resistance R	Ω	80	40	20	8
Rated power P _N	kW	1.25	2.5	5	12.5
Braking power 4 x P _N	kW	5	10	20	50
Peak power P _{max} ¹⁾	kW	7.5	15	30	75
Max. energy consumption E _{max} at P _{max} at 4xP _n	kWs	22.5	45	90	225
	kWs	100	200	400	1000
Thermostatic switch connection		Screw terminal ²⁾ , 4 mm ² (AWG 12)	Screw terminal ²⁾ , 4 mm ² (AWG 12)	Screw terminal ²⁾ , 2.5 mm ² (AWG 14)	Screw terminal ²⁾ , 1.5 mm ² (AWG 16)
Power cable connection		Screw terminal ³⁾ , 4 mm ² (AWG 12)	Screw terminal ³⁾ , 4 mm ² (AWG 12)	M6 threaded bolts for ring cable lug ⁴⁾	M6 threaded bolts for ring cable lug ⁵⁾
Protective conductor connection		M5 bolt	M5 bolt	M6 bolt	M6 bolt
Ventilation clearances (all around)	mm	≥ 100			
Weight	kg	6	12	17	27
Dimensions (W x H x D)	mm	145 x 180 x 540	145 x 360 x 540	450 x 305 x 485	745 x 305 x 485
Degree of protection to IEC 60529		IP20	IP20	IP20	IP20

- 1) Applies to a DC-link voltage of 760 V
- 2) Recommended connection cross-section: 0.75 to 1.5 mm² (AWG 19 ... 16)
- 3) Recommended connection cross-section: 2.5 mm² (AWG 14)
- 4) Recommended connection cross-section: 4 mm² (AWG 12)
- 5) Recommended connection cross-section: 16 mm² (AWG 6)

Recommendation

The MC500 or MC800 motor cable should be used as connecting cable.

9.4.1 Characteristic curves

Duty cycle for braking resistors without a thermostatic switch

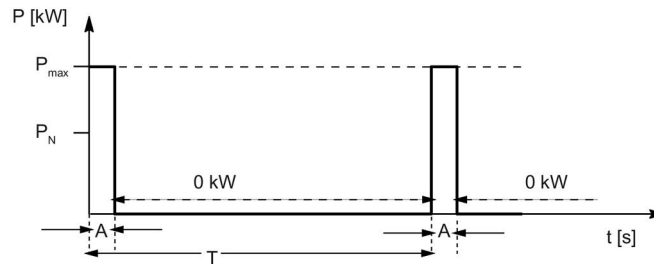

Figure 9-8 Duty cycle for braking resistors without a thermostatic switch

T [s] time period of braking duty cycle

A [s] load duration

P_N [kW] rated power (continuous power) of the braking resistor

P_{max} [kW] peak braking power of the braking resistor

Table 9- 4 Duty cycles for Braking Module Booksize

	6SN1113-1AA00-0DA0		6SL3100-1BE31-0AA.	
	Short duty cycle	Long duty cycle	Short duty cycle	Long duty cycle
A [s]	0.1	0.4	1	2
T [s]	11.5	210	68	460

Table 9- 5 Duty cycles for Braking Module Booksize Compact

	6SN1113-1AA00-0DA0		6SL3100-1BE31-0AA.	
	Short duty cycle	Long duty cycle	Short duty cycle	Long duty cycle
A [s]	0.1	0.4	1	2
T [s]	11.5	46	68	136

The following applies when connecting Braking Modules in parallel:

$P_{N \text{ total}} = 0.9 \times \text{total } P_N \text{ of single devices}$

$P_{max \text{ total}} = \text{total } P_{max} \text{ of single devices}$

Duty cycles for braking resistors with a thermostatic switch

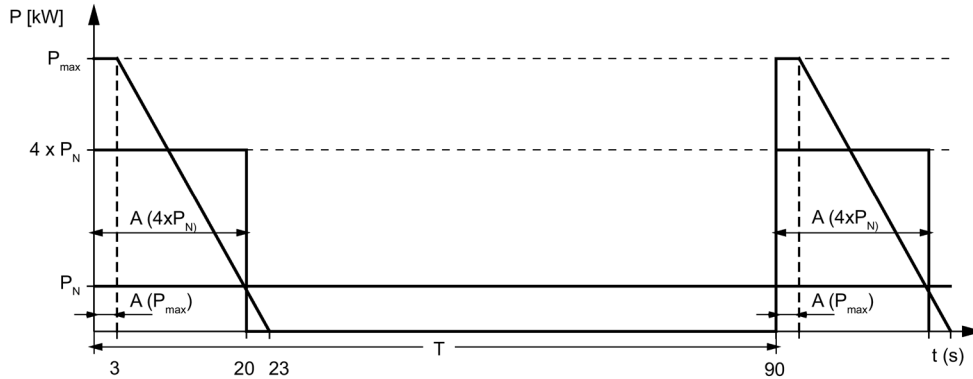

Figure 9-9 Duty cycles for braking resistors with a thermostatic switch

T [s] time period of braking duty cycle

A [s] load duration

P_N [kW] rated power (continuous power) of the braking resistor

P_{max} [kW] peak braking power of the braking resistor

$4 \times P_N$ [kW] = power permitted every 90 s for 20 s

Table 9- 6 Duty cycles

	6SE7018-0ES87-2DC0		6SE7021-6ES87-2DC0		6SE7023-2ES87-2DC0		6SE7028-0ES87-2DC0	
	Duty cycle P_{max}	Duty cycle $4 \times P_N$	Duty cycle P_{max}	Duty cycle $4 \times P_N$	Duty cycle P_{max}	Duty cycle $4 \times P_{N0}$	Duty cycle P_{max}	Duty cycle $4 \times P_N$
A [s]	3	20	3	20	3	20	3	20
T [s]	90	90	90	90	90	90	90	90

The following applies when connecting Braking Modules in parallel:

$P_{N\ total} = 0.9 \times \text{total } P_N \text{ of single devices}$

$4 \times P_{N\ total} = 0.9 \times \text{sum } (4 \times P_N) \text{ of single devices}$

$P_{max\ total} = \text{total } P_{max} \text{ of single devices}$

Motor-side power components

10.1 Motor reactors

10.1.1 Description

Motor reactors reduce discharge currents which means that longer motor cables may be used.

At the same time, the stress on the motor windings caused by rates of voltage rise (dv/dt) is also diminished.

Preconditions

- Maximum ambient temperature: 40 °C
- Maximum pulse frequency 4 kHz
- Maximum output frequency: 120 Hz
- Maximum current limit: 2 x rated current
- Operating modes: Vector control and U/f control

Support in STARTER

- From Version 2.4 and higher: up to 1 motor reactor
- From Version 2.5 and higher: up to 3 motor reactors

10.1.2 Safety instructions for motor reactors



 WARNING
Electric shock in the event of missing touch protection
Touching live components can result in death or severe injury.
<ul style="list-style-type: none">• For the motor reactors, use touch protection according to IPXXA or corresponding to the local installation regulations.



 CAUTION
Burns due to high surface temperatures
The motor reactors can become very hot. You can get seriously burnt when touching the surface.
<ul style="list-style-type: none">• Mount the motor reactors so that contact is not possible. If this is not possible, attach clearly visible and understandable warning notices at hazardous positions.• To prevent adjacent components from suffering damage due to these high temperatures, maintain a clearance of 100 mm on all sides of the motor reactors.

NOTICE
Damaged device due to use of incorrect motor reactors
When using motor reactors that have not been approved by Siemens for SINAMICS, the motor reactors can be damaged.
<ul style="list-style-type: none">• Only use motor reactors that Siemens has approved for operation with SINAMICS.

Note
Maximum cable length of the connection cables

The connection cables to the Motor Module must be kept as short as possible (max. 5 m).

10.1.3 Dimension drawings

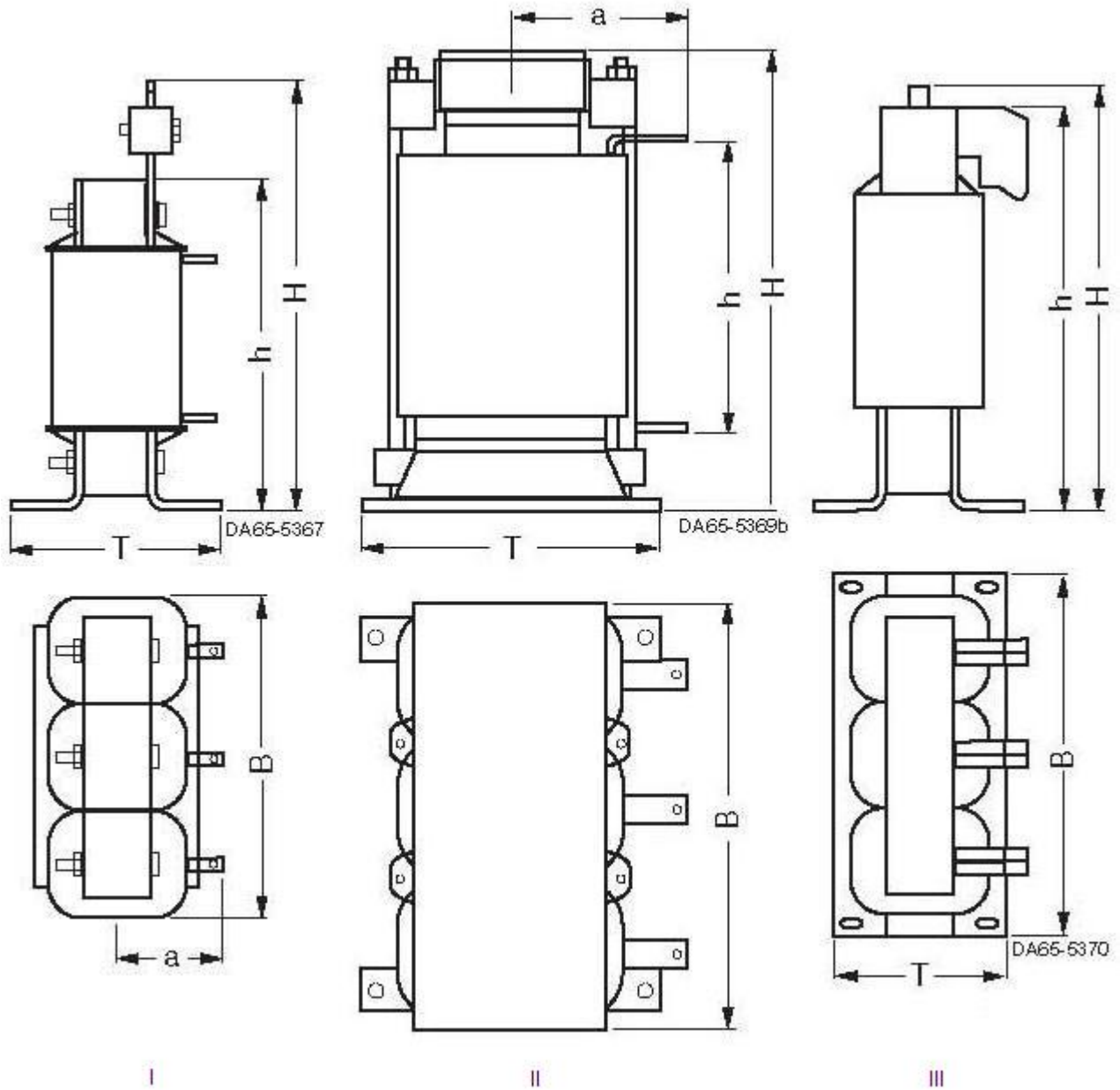

Figure 10-1 Dimension drawings of motor reactors

10.1 Motor reactors

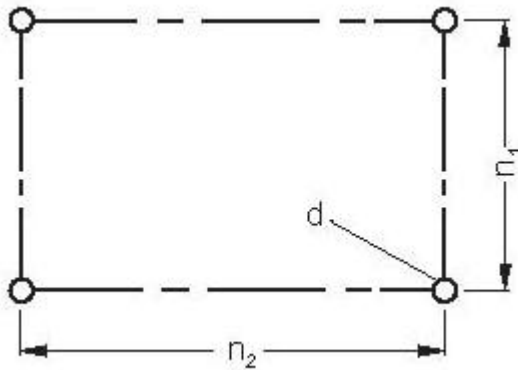

Figure 10-2 Mounting hole

Table 10- 1 Dimensions of motor reactors, all dimensions in mm and (inches)

	6SE7021-0ES87-1FE0	6SE7022-6ES87-1FE0	6SE7024-7ES87-1FE0	6SE7027-2ES87-1FE0
	Fig. III	Fig. III	Fig. II	Fig. I
B	178 (7.00)	219 (8.62)	197 (7.75)	267 (10.51)
H	153 (6.02)	180 (7.08)	220 (8.66)	221 (8.70)
T	88 (3.46)	119 (4.68)	104 (4.09)	107 (4.21)
a	-	-	69 (2.71)	77 (3.03)
h	146 (5.74)	181 (7.12)	103 (4.05)	206 (8.11)
n ₁	68 (2.67)	89 (3.50)	70 (2.75)	77 (3.03)
n ₂	166 (6.53)	201 (7.91)	176 (6.92)	249 (9.80)
d	M5	M6	M6	M6

Lengths n₁ and n₂ correspond to the distances between holes

Table 10- 2 Dimensions of motor reactors, all dimensions in mm and (inches)

	6SE7031-5ES87-1FE0	6SE7031-8ES87-1FE0	6SE7032-6ES87-1FE0
	Fig. II	Fig. II	Fig. II
B	197 (7.75)	281 (11.06)	281 (11.06)
H	220 (8.66)	250 (9.84)	250 (9.84)
T	128 (5.03)	146 (5.74)	146 (5.74)
a	81 (3.18)	98 (3.85)	111 (4.37)
h	100 (3.93)	119 (4.68)	121 (4.76)
n ₁	94 (3.70)	101 (3.97)	101 (3.97)
n ₂	176 (6.92)	200 (7.87)	200 (7.87)
d	M6	M8	M8

Lengths n₁ and n₂ correspond to the distances between holes

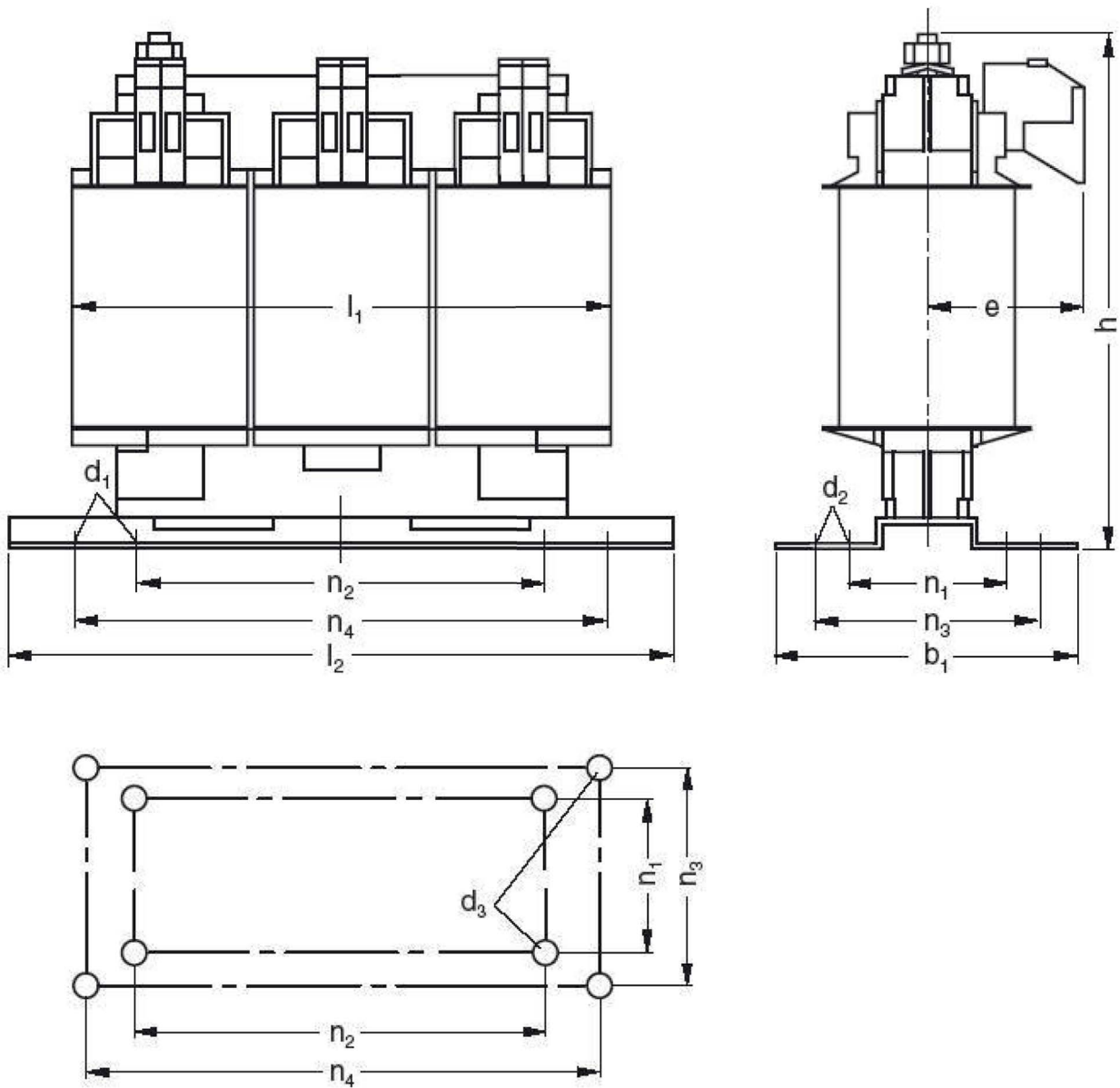

Figure 10-3 Dimension drawing and mounting hole of motor reactor 9 A (6SL3000-2BE21-0AA0)

Table 10-3 Dimensions of motor reactor 9 A, all dimensions in mm and (inches)

6SL3000-2BE21-0AA0	
l_1	150 (5.90)
l_2	178 (7.00)
b_1	88 (3.46)
b_{max}	111 (4.37)
e	67 (2.63)
h	159 (6.25)
n_1	64 (2.51)

10.1 Motor reactors

6SL3000-2BE21-0AA0	
n ₂	113 (4.44)
n ₃	68 (2.67)
n ₄	166 (6.53)
d ₁	5.8 (0.22)
d ₂	11 (0.43)
d ₃	M5
Protective conductor	M6
Lengths n ₁ , n ₂ , n ₃ and n ₄ correspond to the distances between holes	

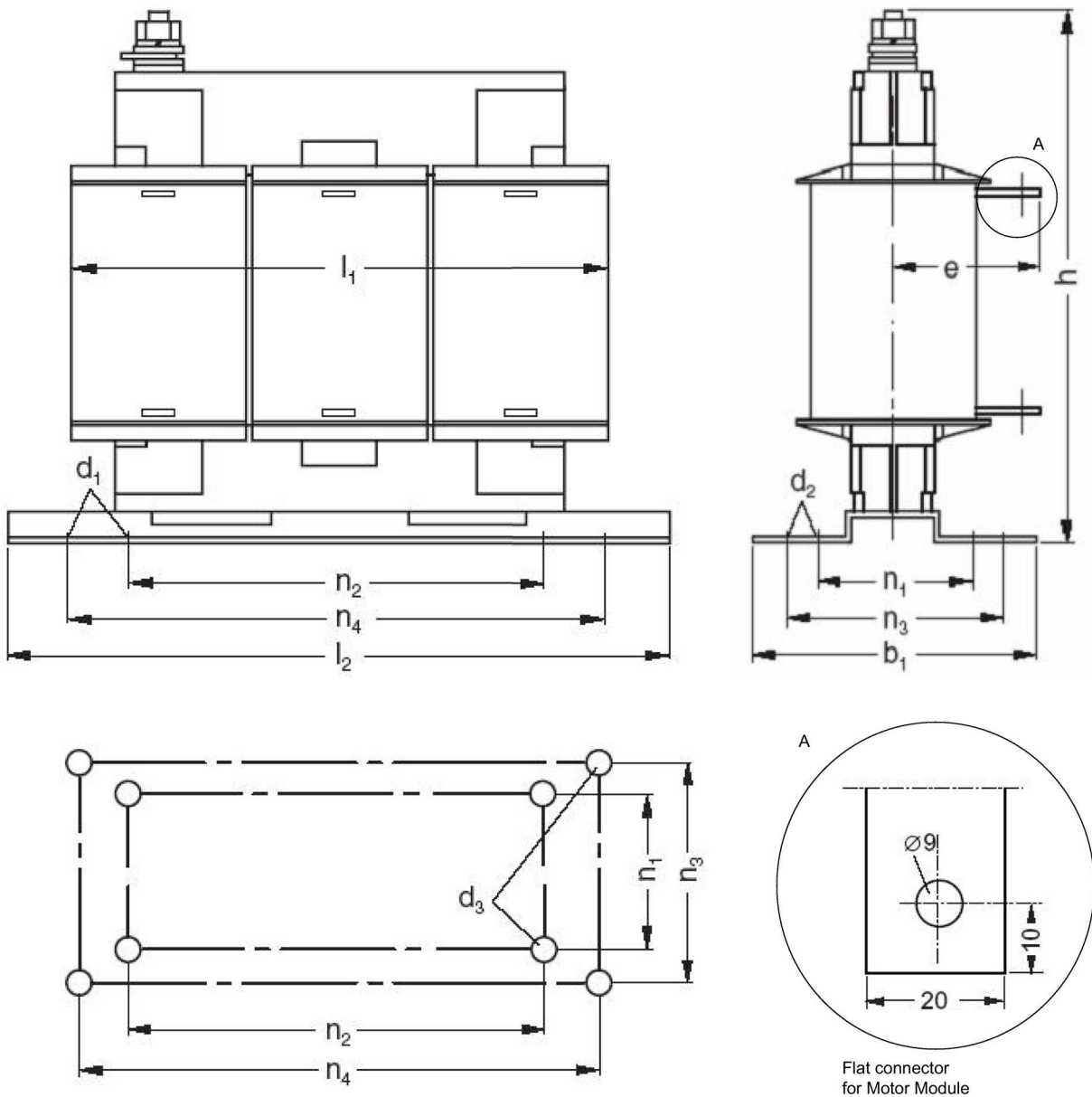

Figure 10-4 Dimension drawing and mounting hole of motor reactor 60 A (6SL3000-2BE26-0AA0)

Table 10- 4 Dimensions of motor reactor 60 A, all dimensions in mm and (inches)

6SL3000-2BE26-0AA0	
l ₁	Max. 228 (8.97)
l ₂	267 (10.51)
b ₁	107 (4.21)
b _{max}	125.5 (4.94)
e	72 (2.83)
h	220 (8.66)
h ₁	56 (2.20)
h ₂	100 (3.93)
n ₁	70 (2.75)
n ₂	176 (6.92)
n ₃	77 (3.03)
n ₄	249 (9.80)
d ₁	36 (1.41)
d ₂	3.5 (0.13)
d ₃	M6
Protective conductor	M6
Lengths n ₁ , n ₂ , n ₃ and n ₄ correspond to the distances between holes	

10.1.4 Technical data

Table 10- 5 Technical data, motor reactors, part 1

Article No.		6SE7021-0ES87-1FE0	6SL3000-2BE21-0AA0	6SE7022-6ES87-1FE0	6SE7024-7ES87-1FE0	6SE7027-2ES87-1FE0
Matching the Motor Module		6SL312x-1TE13-0AA. 6SL312x-2TE13-0AA. 6SL312x-1TE15-0AA. 6SL312x-2TE15-0AA. 6SL342x-1TE13-0AA. 6SL342x-2TE13-0AA. 6SL342x-1TE15-0AA. 6SL342x-2TE15-0AA.	6SL312x-1TE21-0AA. 6SL312x-2TE21-0AA. 6SL342x-1TE21-0AA.	6SL312x-1TE21-8AA. 6SL312x-2TE21-8AA. 6SL342x-1TE21-8AA.	6SL312x-1TE23-0AA.	6SL312x-1TE24-5AA.
Rated current	A	5	9	18	30	45
Inductance	μH	1243	1000	332	180	59
Power loss	W	80	90	110	190	200
Motor Module/motor connection		Screw terminals 4 mm ² (AWG 12)	Screw terminals 16 mm ² (AWG 6)	Screw terminals 16 mm ² (AWG 6)	Flat connector for M8 screw	
Protective conductor connection		Threaded bolts M6				
Degree of protection		IP00	IP00	IP00	IP00	IP00
Ventilation clearances above/below	mm	≥ 100				
Weight	kg	5.5	4.8	7.8	13	11

Table 10- 6 Technical data, motor reactors, part 2

Article No.		6SL3000-2BE26-0AA0	6SE7031-5ES87-1FE0	6SE7031-8ES87-1FE0	6SE7032-6ES87-1FE0	
Matching the Motor Module		6SL312x-1TE26-0AA.	6SL312x-1TE28-5AA.	6SL312x-1TE31-3AA.	6SL312x-1TE32-0AA.	
Rated current	A	60	85	132	200	
Inductance	μH	62	29	23	16	
Power loss	W	105	222	291	291	
Motor Module/motor connection		Flat connector for M8 screw		Flat connector for M10 screw		
Protective conductor connection		Threaded bolts M6				

Article No.		6SL3000-2BE26-0AA0	6SE7031-5ES87-1FE0	6SE7031-8ES87-1FE0	6SE7032-6ES87-1FE0
Degree of protection		IP00	IP00	IP00	IP00
Ventilation clearances above/below	mm	≥ 100			
Weight	kg	10.5	20.5	27.2	30.6

Table 10-7 Cable lengths, Part 1

Article No.	6SE7021-0ES87-1FE0	6SL3000-2BE21-0AA0	6SE7022-6ES87-1FE0	6SE7024-7ES87-1FE0	6SE7027-2ES87-1FE0
Rated current [A]	5	9	18	30	45
Shielded cables					
Maximum motor cable length, 1 reactor	100	135	160	190	200
Maximum motor cable length, 2 reactors	-	-	320	375	400
Maximum motor cable length, 3 reactors	-	-	-	-	600
Unshielded cables					
Maximum motor cable length, 1 reactor	150	200	240	280	300
Maximum motor cable length, 2 reactors	-	-	480	560	600
Maximum motor cable length, 3 reactors	-	-	-	-	900

Table 10-8 Cable lengths, Part 2

Article No.	6SL3000-2BE26-0AA0	6SE7031-5ES87-1FE0	6SE7031-8ES87-1FE0	6SE7032-6ES87-1FE0
Rated current [A]	60	85	132	200
Shielded cables				
Maximum motor cable length, 1 reactor	200	200	200	200
Maximum motor cable length, 2 reactors	400	400	400	400
Maximum motor cable length, 3 reactors	600	600	600	600
Unshielded cables				
Maximum motor cable length, 1 reactor	300	300	300	300
Maximum motor cable length, 2 reactors	600	600	600	600
Maximum motor cable length, 3 reactors	900	900	900	900

10.2 Voltage Protection Module VPM

10.2.1 Description

The Voltage Protection Module (VPM) is a component for limiting voltage. It is used for both 1FE1 and 2SP1 motors and those with an electromagnetic force (EMF) of between 800 V and 2000 V to limit DC-link voltage if a fault occurs.

The Voltage Protection Module is installed within the motor cable between the Motor Module and motor. If the line voltage fails at the maximum motor speed or the pulses at the Motor Module are canceled as a result of the power failure, the motor regenerates at high voltage into the DC link. The Voltage Protection Module recognizes that the motor voltage is too high (> 800 V) and uses an electronic switch to short-circuit the three phases of the motor at its supply lines. The power remaining in the motor is converted to heat via the short circuit between the Voltage Protection Module and motor cables.

The Voltage Protection Module is available in 3 versions.

Table 10- 9 Overview of the Voltage Protection Modules available

Designation	Rated current
VPM120	120 A
VPM200	200 A
VPM200 Dynamic	200 A

Table 10- 10 Interface overview for Voltage Protection Modules

Type	Number VPM120/VPM200	Number VPM200 Dynamic
Signaling contact	1	1
Protective conductor connection	2	4
Load connecting bolt, input	3	5
Load connecting bolt, output	3	5

10.2.2 Safety instructions for Voltage Protection Modules



WARNING

Electric shock due to the residual charge of the DC-link capacitors

Due to the DC link capacitors of the converter, a hazardous voltage is present in the DC link for up to 30 minutes after the power supply has been switched off.

Contact with live parts can result in death or serious injury.

- Avoid contact with the Voltage Protection Module as long as it is under voltage.



WARNING

Electric shock as a result of excessive speed of the motor during ramp-up of VPM

If the motor is operated with a speed higher than the field weakening threshold speed while the Voltage Protection Module is ramping up (see the technical data), the protection function of the VPM is inactive during this phase. As a consequence, high voltages can be injected into the DC link.

Contact with live parts can result in death or serious injury.

- Only operate the motor below the field weakening threshold speed while the VPM is ramping up.



WARNING

Electric shock if the insulation voltage is exceeded

An excessively high voltage will damage the insulation resulting in death or severe injury.

- Do not connect any motors whose electromotive force (EMF) exceeds the permissible value at the highest speed used.
- Route the cables so that they are protected to rule out any damage.



WARNING

Electric shock due to using unsuitable third-party motors

VPM can be used with third-party motors. If, when using third-party motors, the VPM does not limit the DC-link voltage, this can result in death or severe injury.

- Please observe the following when using third-party motors:
 - Carry out a risk analysis.
 - Ensure that the third-party motors correspond to the electrical properties of the specified Siemens components.
 - Check the correct functioning of the VPM.

 WARNING
Danger to life through automatic start of the drive An uncontrolled automatic start of the drive can result in fatal accidents. <ul style="list-style-type: none">• Take precautions against an automatic start of the drive.

NOTICE
Damage when using motors that are not short-circuit proof Using motors that are not short-circuit proof in conjunction with a Voltage Protection Module can result in damage. <ul style="list-style-type: none">• Only use motor that are short-circuit proof.

NOTICE
Damage to devices as a result of incorrect connecting cables Using incorrect connecting cables for Voltage Protection Modules can damage the connected components. <ul style="list-style-type: none">• Use shielded MOTION-CONNECT 800PLUS motor cables, type 6FX8.

10.2.3 Interface description

10.2.3.1 Overview

The drawings below show the basic positions of interfaces and the housing openings of the Voltage Protection Modules VPM120, VPM200 and VPM200 Dynamic.

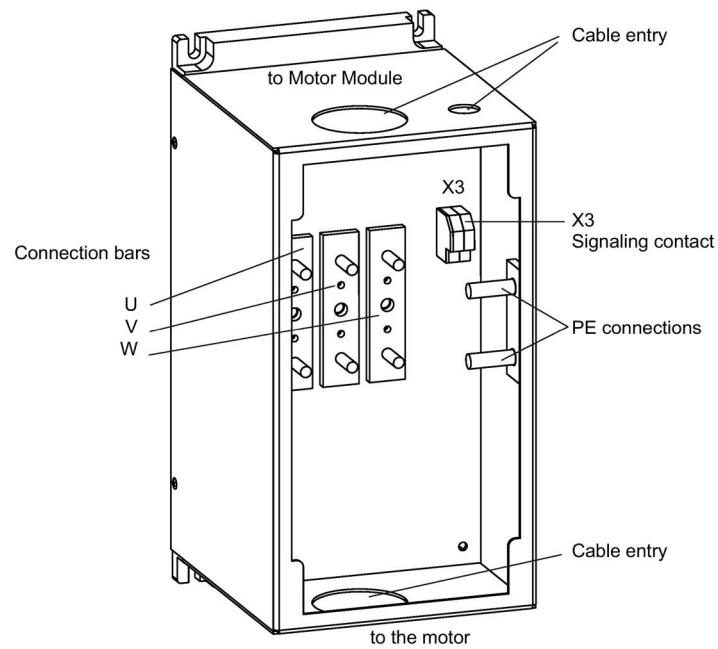

Figure 10-5 Interface overview, Voltage Protection Modules VPM120 (without cover)

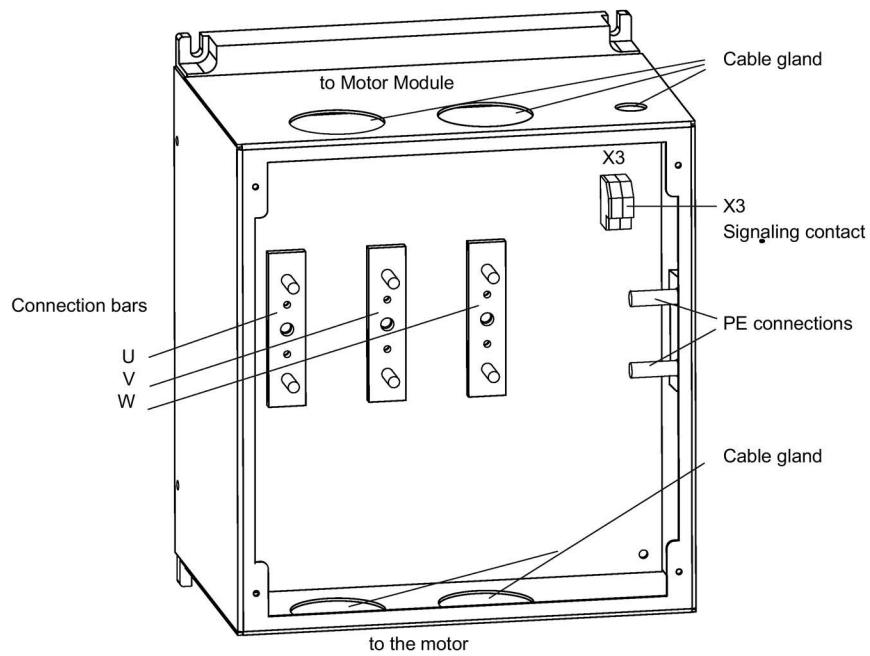

Figure 10-6 Interface overview, Voltage Protection Modules VPM200 (without cover)

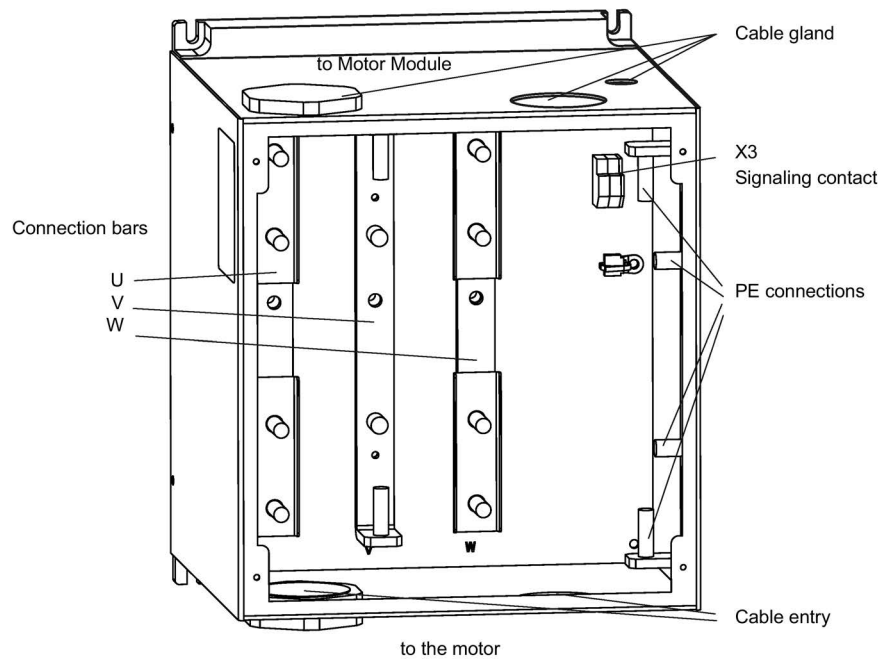

Figure 10-7 Interface overview, Voltage Protection Modules VPM200 Dynamic (without cover)

The housing is closed during operation to ensure the electrical terminals are covered.

10.2.3.2 X3 signaling contact

The signaling contact has the following assignments:

Table 10- 11 X3 signaling contact

Terminal	Designation	Technical data
1	Operating message for Control Unit	<ul style="list-style-type: none"> The cable shield is connected to the VPM housing via the cable entry. Isolated contact, current carrying capacity: 30 V DC at 0.1 A
2	Operating voltage +24 V (from external source)	
Type: WAGO spring-loaded terminal, type 226-111 Max. conductor cross-section: 1.5 mm ² (AWG 16) Shielded cable		
Cable gland: Max. 9 mm Ø Types VPM120, VPM200 and VPM200 Dynamic		
<ul style="list-style-type: none"> Screwed joint: 1 x M16, e.g. from Pflitsch, article designation: UNI DICHT EMV 2165211S05 Locknut M16: GM216PA 		

Operating message via signaling contact X3

After a Voltage Protection Module response or in the event of a temperature error, signaling contact X3 opens and interrupts the inverter system's pulse enable.

The X3 signal contact automatically closes after $t > 120$ s or after resetting the temperature switch.

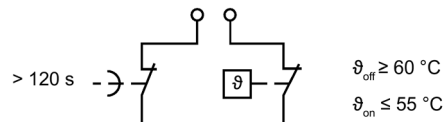

Figure 10-8 Signaling contact X3 of the Voltage Protection Module

⚠ WARNING
<p>Danger to life when the drive automatically starts to run in an uncontrolled fashion</p> <p>An uncontrolled automatic start of the drive can result in death or severe injury.</p> <ul style="list-style-type: none"> Take measures to prevent the drive starting automatically in an uncontrolled fashion, as signal contact X3 restores the pulse enable after 2 minutes.

10.2.3.3 Connection bars U, V, W, PE

The cables to the Motor Module and motor are routed through the cable entry of the Voltage Protection Module and attached to the connection bars inside the unit.

Table 10- 12 Connections U, V, W, and PE

	VPM120	VPM200	VPM200 Dynamic
Connection bolt	8 x M6 ¹⁾	8 x M8 ¹⁾	14 x M8 ²⁾
Cable lug	Crimp-type cable lug M6	Crimp-type cable lug M8	Tubular cable lug M8, 90° angled
Cable cross-section	≤ 50 mm ² (AWG 1)	≤ 50 mm ² (AWG 1)	≤ 50 mm ² (AWG 1)
Tightening torque	10 Nm (88.5 lbf in)	25 Nm (221 lbf in)	25 Nm (221 lbf in)
Cable entry	For cables with max. 40 mm Ø		
Gland ³⁾	2 x M50 e.g. from Pflitsch, article designation: UNI DICHT EMV 250584117 Locknut M50: GM250PA	4 x M50 e.g. from Pflitsch, article designation: UNI DICHT EMV 250584117 Locknut M50: GM250PA	4 x M50 e.g. from Pflitsch, article designation: UNI DICHT EMV 250584117 Locknut M50: GM250PA

- 1) There are 2 connection points for each phase and for PE.
- 2) There are 4 connection points for each of the phases U, W, and PE and 2 connection points for phase V.
- 3) The glands must be separately ordered.

Note

Cable lengths with cross-sections of > 50 mm² (AWG 1) between the Motor Module and the Voltage Protection Module or between the Voltage Protection Module and the motor are implemented using two cables connected in parallel.

10.2.4 Connection examples

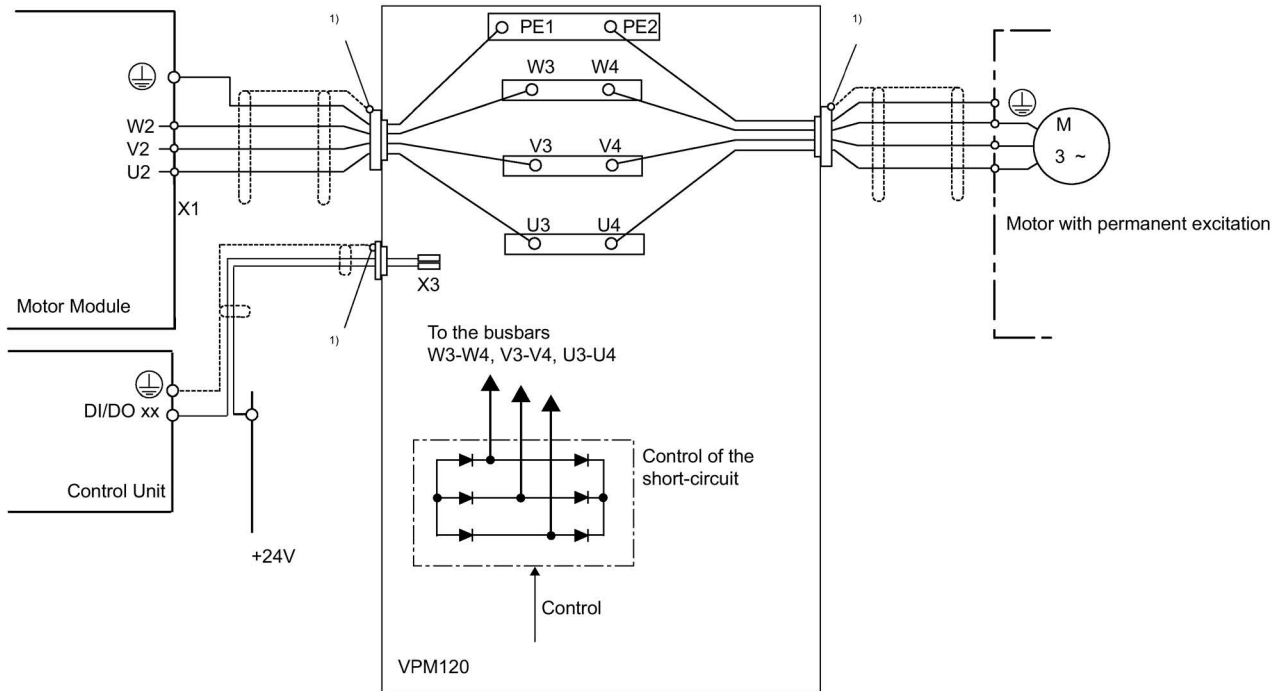

¹⁾Conductive connection of cable shield with cable bushing

Figure 10-9 Connection example for Voltage Protection Module VPM120

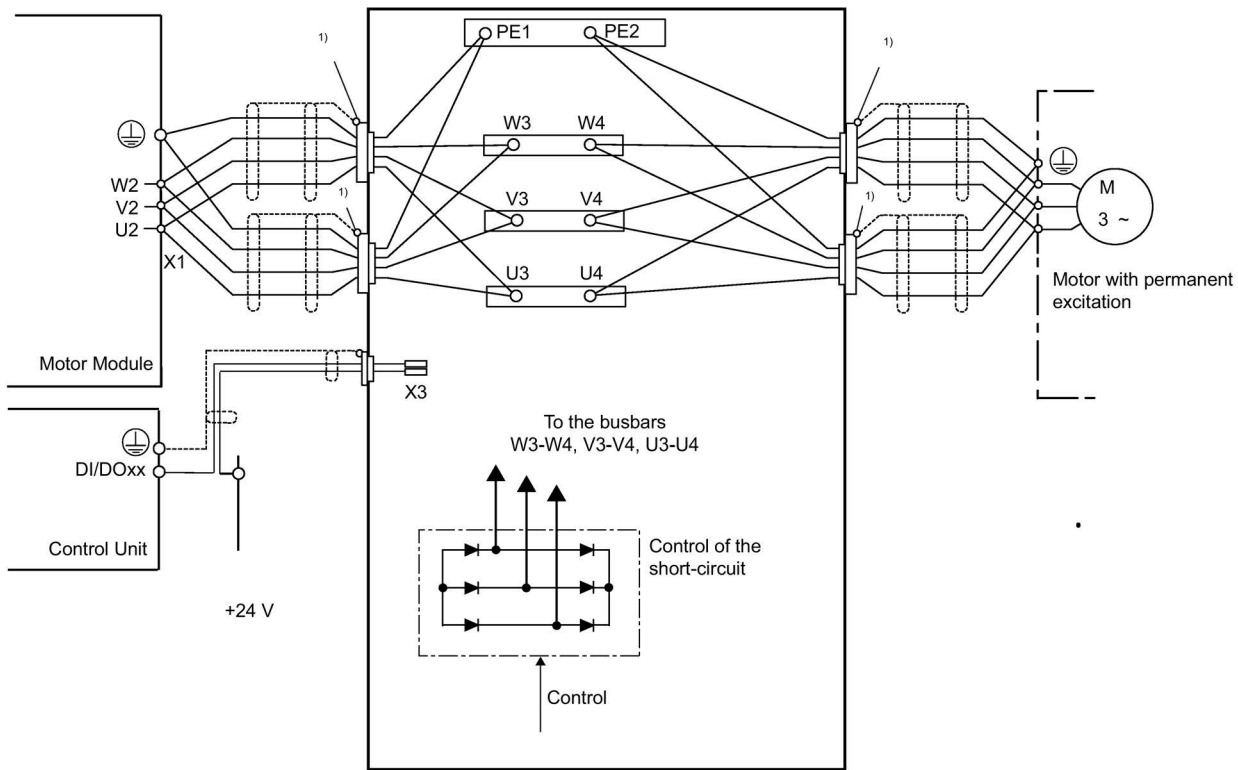

¹⁾ Conductive connection of cable shield with the cable bushing

Figure 10-10 Connection example for Voltage Protection Module VPM200

Cable lengths

The maximum length of the power cable between the Motor Module and the Voltage Protection Module is 1.5 m and must not include any switching elements. The power cable between the Voltage Protection Module and the motor must not exceed a length of 50 m.

Signaling contact

Signaling contact X3 on the Voltage Protection Module is wired to a digital input (DI) on the Control Unit, which controls this spindle. If more than one Voltage Protection Module is used, each X3 terminal is wired to the respective Control Unit. If an armature short-circuit occurs, the pulses of the axis involved must remain inhibited. To do this, the connected digital input is interconnected to control bit OFF2 (pulse inhibit) (see SINAMICS S120/S150 List Manual). The signaling contact is operated with +24 V.

10.2.5 Dimension drawings

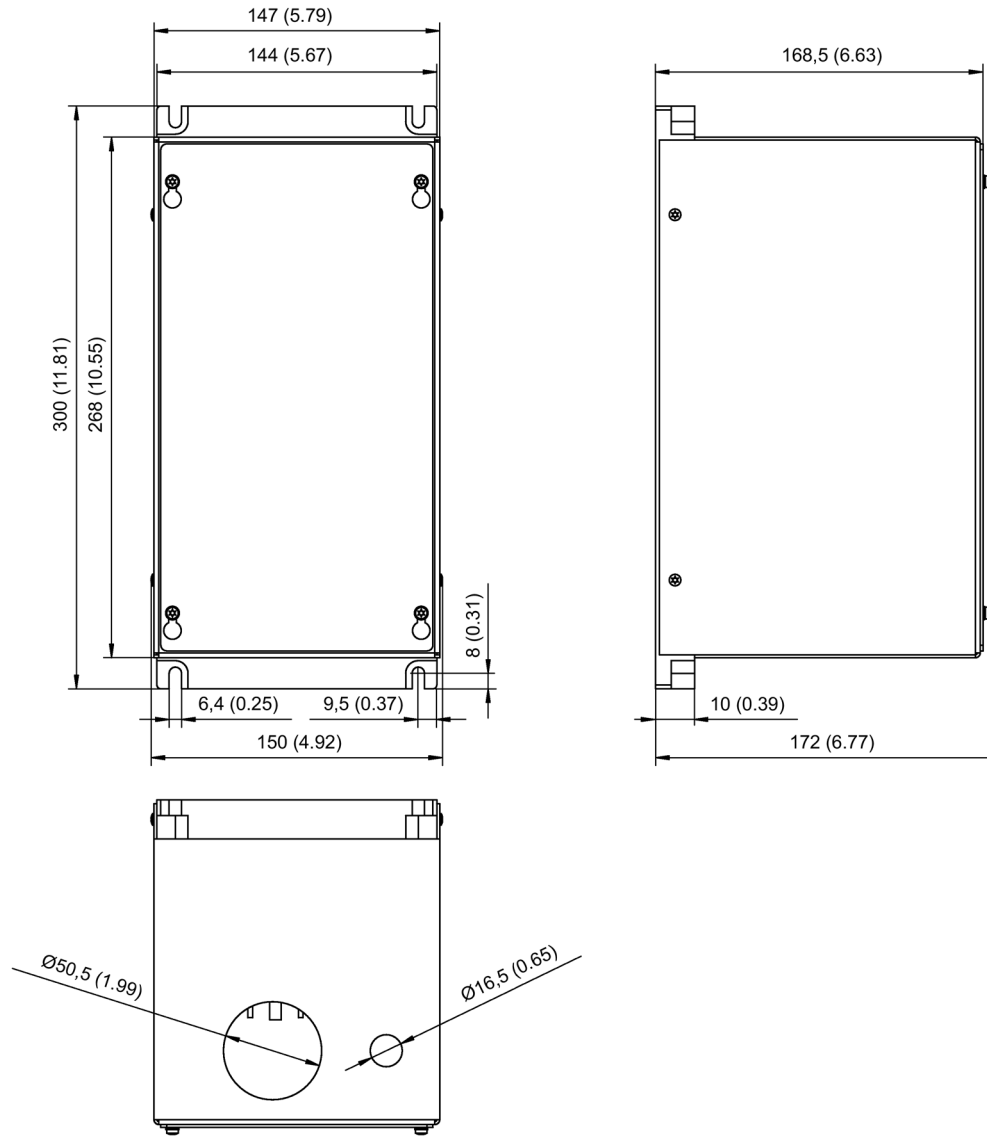

Figure 10-11 Dimension drawing of the Voltage Protection Module VPM120, all data in mm and (inches)

10.2 Voltage Protection Module VPM

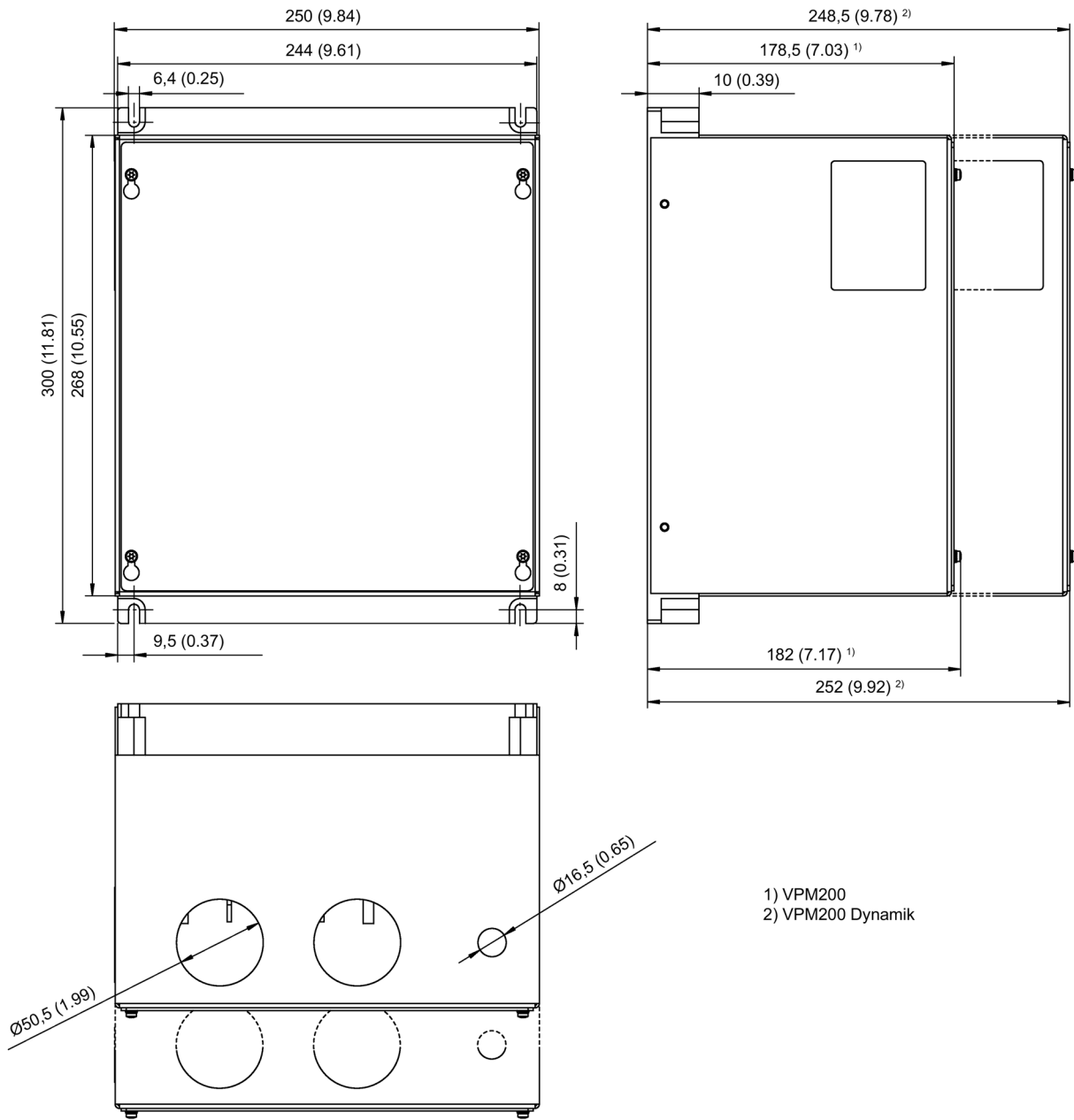

Figure 10-12 Dimension drawing of the Voltage Protection Module VPM200 and VPM200 Dynamic, all data in mm and (inches)

10.2.6 Installation

The Voltage Protection Module is installed in the control cabinet close to the drive.

Note

Connecting motor reactors

Motor reactors may only be connected between the Voltage Protection Module and motor.

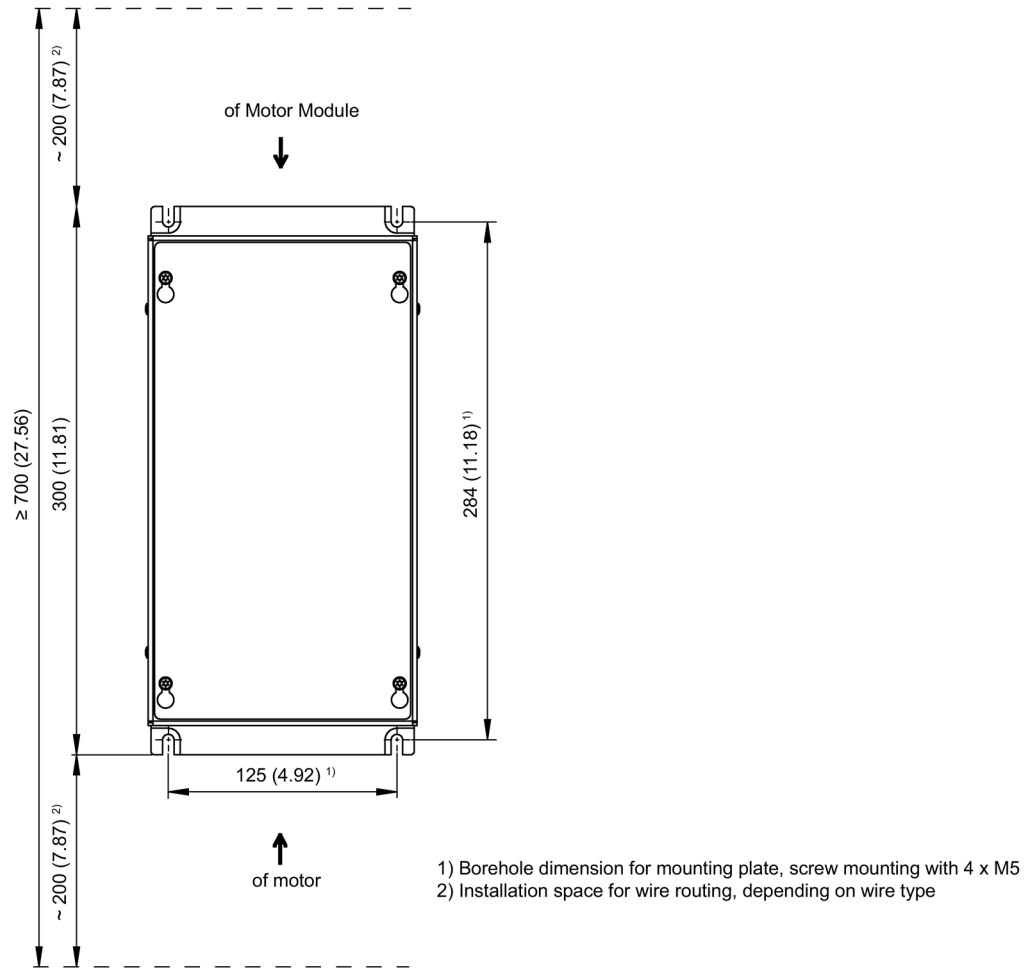

Figure 10-13 Mounting dimension for a Voltage Protection Module VPM120

10.2 Voltage Protection Module VPM

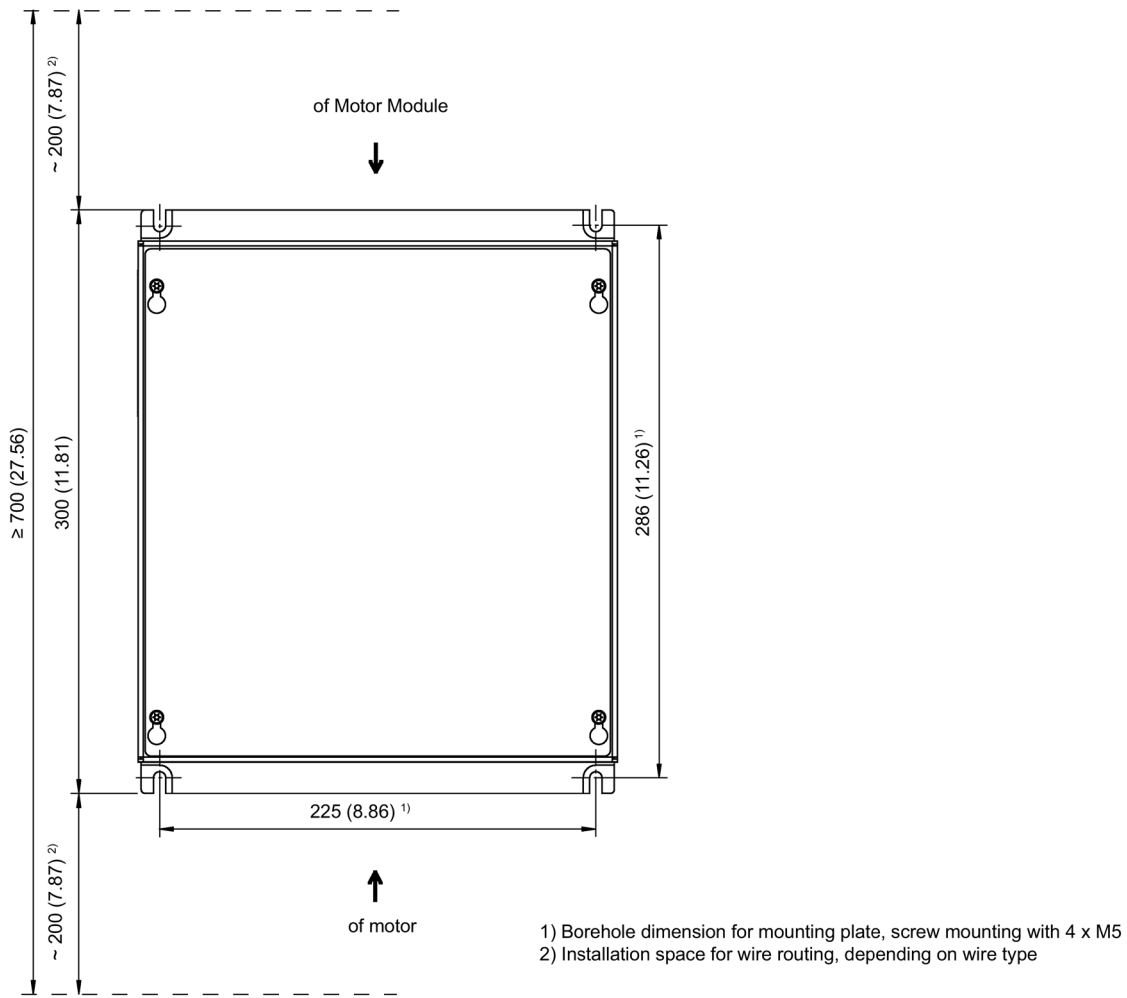

Figure 10-14 Mounting dimensions for a Voltage Protection Module VPM200

10.2.7 Electrical connection

Note

Only the enclosure cover may be opened when electrically connecting the Voltage Protection Module.

Introduction

Various types of cabling work must be carried out in order to integrate a Voltage Protection Module into a motor feeder circuit. All connections must be set up inside the VPM housing. Cable cross-sections are determined by the rated motor power and may be as much as 2 x 50 mm² for each conductor. An installation sequence for individual conductors is outlined below. It is particularly relevant for larger cross-sections.

Preparation

The following preparations must be made before setting up connections:

- Loosen the 4 screws on the cover of the housing, so that the cover can be shifted in the cutouts.
- Move the enclosure cover to the point where the cutout widens out so it can be lifted over the screw heads.
- Attach the cable glands for the signal cable and power cables (2x for the VPM120, 4x for the VPM200) at the entries into the housing of the Voltage Protection Module.
- Remove 300 mm of the cable sheath of the power cables and expose the shield to match the housing gland being used.
- Remove the insulation at the ends of the individual conductors and attach cable lugs.
- Attach the signal cable to X3 and secure the cable with cable ties inside the Voltage Protection Module.

10.2.7.1 Connecting signaling contact X3

The signaling contact X3 must be wired before connecting the power cables.



- ① Cable tie
- ② Signaling contact X3

Figure 10-15 Connection of the signaling contact using the VPM200 as an example

The X3 signaling contact is routed via a bistable relay. The relay may shift to the other switching state if subjected to excessive movement during transportation and installation. This may prevent the system from starting.

NOTICE

Damage as the short-circuit thyristor is still conducting

When a Voltage Protection Module is tripped and the short-circuit thyristor is still conducting before the converter is switched on again, then this can result in damage to the system.

- The motor must have come to a standstill.
- Signal contact X3 must have closed again.
- Check that the thyristor is in a no voltage condition.

Cause and rectification of faults

The "Installation" sections in the documents referred to below contain additional information on the causes of faults and how they can be rectified:

- Operating Instructions for Voltage Protection Module VPM120, Article No.: A5E00302281B
- Operating Instructions for Voltage Protection Module VPM200, Article No.: A5E00777655A
- Operating Instructions for Voltage Protection Module VPM200 Dynamic, Article No.: A5E00302261B

10.2.7.2 Connecting power cables (using the VPM 200 Dynamik as an example)

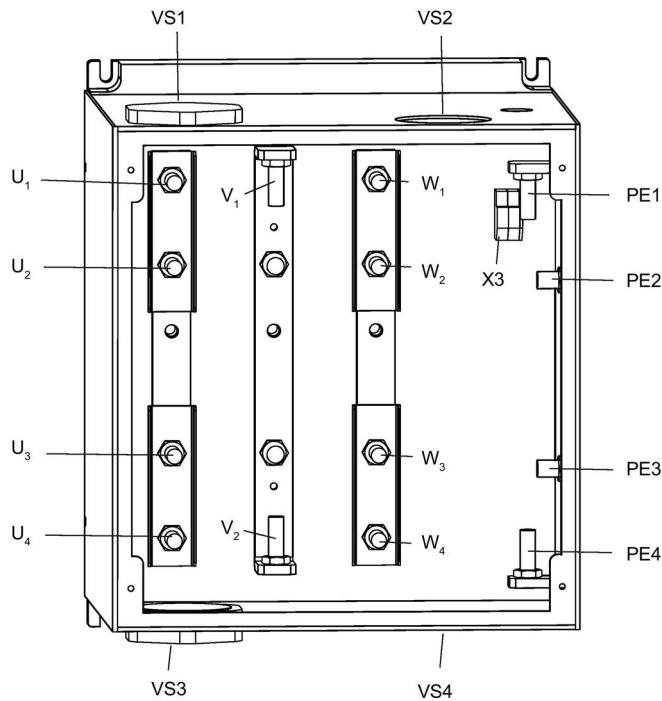

Figure 10-16 Connection points of the Voltage Protection Module VPM200 Dynamic

Table 10- 13 Short designations

Short designation	Explanation
VS1, VS2	Cable screwed joint 1 or 2 in the housing entry of the VPM, towards Motor Module
VS3, VS4	Cable screwed joint 3 or 4 in the housing entry of the VPM, towards motor
K1, K2	Cable 1 or 2 to the Motor Module
K3, K4	Cable 3 or 4 to the motor
U ₁ , U ₂	Connection bolts on busbar U
U ₃ , U ₄	Connection bolts on busbar U
V ₁ , V ₂	Connection bolts on busbar V
W ₁ , W ₂	Connection bolts on busbar W
W ₃ , W ₄	Connection bolts on busbar W
PE ₁ , PE ₂ , PE ₃ , PE ₄	Connection bolts on busbar PE
U	Busbar U in the VPM
V	Busbar V in the VPM
W	Busbar W in the VPM

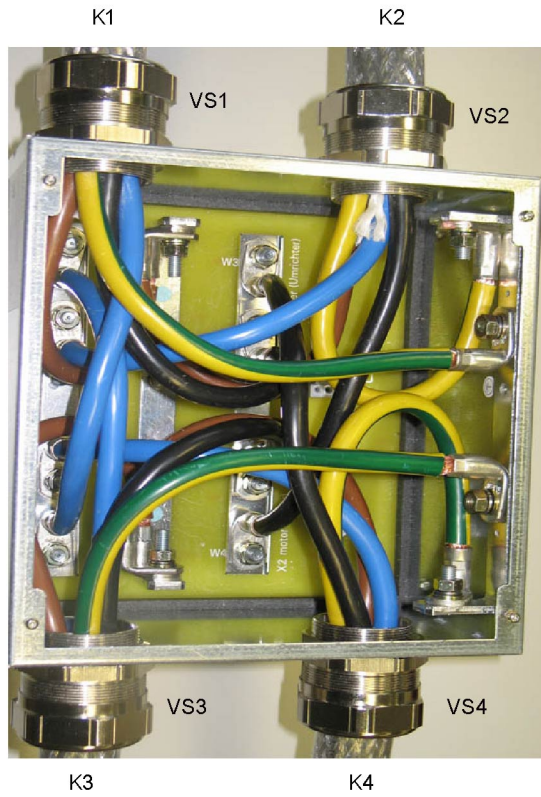

Figure 10-17 Wired Voltage Protection Module VPM200 Dynamic with short designations

Table 10- 14 Installation steps

Cable glands	Cable	Conductor/Phase	Installation step
VS1	K1	L ₁ , L ₂ , L ₃ , PE	Introduce the cable with all the conductors and shield, tighten the gland and lay conductors L ₁ (black) and PE (green/yellow) on top of the other conductors.
VS2	K2	L ₁ , L ₂ , L ₃ , PE	Introduce the cable with all the conductors and shield, tighten the gland and lay conductors L ₁ (black) and PE (green/yellow) on top of the other conductors.
	K1	L ₂ (blue)	Lay L ₂ on V1 and screw these together.
	K2	L ₂ (blue)	Lay L ₂ on V1 and screw these together.
	K2	PE (green/yellow)	Lay PE on PE1 and screw these together.
	K1	L ₃ (brown)	Lay L ₃ on W2 and screw these together.
	K2	L ₁ (black)	Lay L ₁ on U2 and screw these together.
3 separate cable ends for cables K1 and K2 are connected later.			
VS3	K3	L ₁ , L ₂ , L ₃ , PE	Introduce the cable with all the conductors and shield, tighten the gland and lay conductors L ₁ (black) and PE (green/yellow) on top of the other conductors.
VS4	K4	L ₁ , L ₂ , L ₃ , PE	Introduce the cable with all the conductors and shield, tighten the gland and lay conductors L ₁ (black) and PE (green/yellow) on top of the other conductors.
	K3	L ₂ (blue)	Lay L ₂ on V2 and screw these together.
	K4	L ₂ (blue)	Lay L ₂ on V2 and screw these together.
	K3	L ₃ (brown)	Lay L ₃ on W3 and screw these together.
	K4	PE (green/yellow)	Lay PE on PE4 and screw these together.
	K4	L ₁ (black)	Lay L ₁ on U3 and screw these together.
	K1	L ₁ (black)	Lay L ₁ on U4 and screw these together.
	K3	L ₁ (black)	Lay L ₁ on U1 and screw these together.
	K2	L ₃ (brown)	Lay L ₃ on W4 and screw these together.
	K4	L ₃ (brown)	Lay L ₃ on W1 and screw these together.
	K3	PE (green/yellow)	Lay PE on PE3 and screw these together.
	K1	PE (green/yellow)	Lay PE on PE2 and screw these together.

10.2.8 Technical data

Table 10- 15 Technical data

	VPM 120	VPM 200	VPM 200 Dynamic
Article No.	6SN1113-1AA00-1JA.	6SN1113-1AA00-1KA.	6SN1113-1AA00-1KC.
Type of voltage	3-phase pulsed AC voltage, motor EMF		
Ramp-up time for VPM	1 s (from pulse enable)		
Normal range of the DC link voltage: - lower limit - upper limit	490 V DC 795 V DC		
Operating range for VPM	830 ... 2000 V (peak value)		
Motor EMF	< 1.4 kV _{rms}		
Clock frequency	3.2 ... 8 kHz		
Rated current	120 A _{rms}	200 A _{rms}	
Time range	Maximum permissible short-circuit current		
0 ... 10 ms	1500 A	2000 A	
10 ... 500 ms	255 A	600 A	
500 ms ... 2 min	90 A	200 A	
> 2 min	0 A	0 A	
Max. perm. short-circuit time	120 s		
Safe electrical separation	Between the signal contact and motor cables U, V, W, UL 508 C		
Permitted humidity	< 90 %		
Humidity classification according to EN 60721-3-3	Cl. 3K5, condensation and icing excluded Low air temperature 0 °C		
Permissible ambient temperature	0 ... 55 °C		
Cooling method	Air-cooled, free convection		
Weight	Approx. 6 kg	Approx. 11 kg	Approx. 13 kg
Dimensions (H x W x D) [mm]	300 x 150 x 180	300 x 250 x 190	300 x 250 x 260

Accessories

11.1 Shield connecting plates for power supply and motor cables

11.1.1 Description

Shield connection plates are available to connect the shields of line and motor power cables as well as brake cables for all Line Modules, Motor Modules, and Active Interface Modules.

A shield connection terminal and/or clamp is used to connect the cable shield to the shield connection plate. Shield supports must be properly arranged to ensure EMC compliance.

11.1.2 Shield connecting plates

Table 11- 1 Shield connection for components with internal air cooling

Component	Power	Total width of component	Shield connection plate	Recommended shield connection
Line Module	5 kW / 10 kW	50 mm	Included in the scope of delivery	
	16 kW	100 mm	Included in the scope of delivery	KLBÜ CO4 ¹⁾
	36 kW	150 mm	6SL3162-1AF00-0AA1	KLBÜ CO4 ¹⁾
	55 kW	200 mm	6SL3162-1AH01-0AA0	Clamps
	80 kW / 120 kW	300 mm	6SL3162-1AH00-0AA0	Clamps
Motor Module	3 ... 18 A 2 x 3 A ... 2 x 9 A	50 mm	Integrated in the motor connector	
	18 A (compact) 2 x 1.7 A ... 2 x 5 A	75 mm	Integrated in the motor connector	
	30 A and 2 x 18 A	100 mm	Integrated in the motor connector	
	45 A and 60 A	150 mm	6SL3162-1AF00-0AA1	KLBÜ CO1 ¹⁾ for the brake cable KLBÜ CO4 ¹⁾ for the motor cable
	85 A	200 mm	6SL3162-1AH01-0AA0	KLBÜ CO1 ¹⁾ for brake cable clamps for motor cable
	132 A and 200 A	300 mm	6SL3162-1AH00-0AA0	KLBÜ CO1 ¹⁾ for brake cable clamps for motor cable
Active Interface Module	16 kW	100 mm	Included in the scope of delivery	KLBÜ CO4 ¹⁾
	36 kW	150 mm	6SL3163-1AF00-0AA0	KLBÜ CO4 ¹⁾
	55 kW	200 mm	6SL3163-1AH00-0AA0	Clamps
	80 kW / 120 kW	300 mm	6SL3163-1AM00-0AA0	Clamps

¹⁾ Shield connection terminal, Weidmüller Company

11.1 Shield connecting plates for power supply and motor cables

Table 11- 2 Shield connection for components with external air cooling

Component	Power	Total width of component	Shield connection plate	Recommended shield connection
Line Module	5 kW / 10 kW	50 mm	Included in the scope of delivery	KLBÜ CO4 ¹⁾
	16 kW	100 mm		
	36 kW	150 mm	6SL3162-1AF00-0BA1	KLBÜ CO4 ¹⁾
	55 kW	200 mm	6SL3162-1AH01-0BA0	Clamps
	80 kW / 120 kW	300 mm	6SL3162-1AH00-0AA0	Clamps
Motor Module	3 ... 18 A 2 x 3 A ... 2 x 9 A	50 mm	Integrated in the motor connector	
	30 A and 2 x 18 A	100 mm	Included in the scope of delivery	KLBÜ CO4 ¹⁾
	45 A and 60 A	150 mm	6SL3162-1AF00-0BA1	KLBÜ CO1 ¹⁾ for the brake cable KLBÜ CO4 ¹⁾ for the motor cable
	85 A	200 mm	6SL3162-1AH01-0BA0	KLBÜ CO1 ¹⁾ for brake cable clamps for motor cable
	132 A and 200 A	300 mm	6SL3162-1AH00-0AA0	KLBÜ CO1 ¹⁾ for brake cable clamps for motor cable

1) Shield connection terminal, Weidmüller Company

Table 11- 3 Shield connection for components with cold plate

Component	Power	Total width of component	Shield connection plate	Recommended shield connection
Line Module	5 kW / 10 kW	50 mm	Included in the scope of delivery	KLBÜ CO4 ¹⁾
	16 kW	100 mm		
	36 kW	150 mm	6SL3162-1AF00-0BA1	KLBÜ CO1 ¹⁾ and KLBÜ CO4 ¹⁾
	55 kW	200 mm	6SL3162-1AH01-0BA0	Clamps
	80 kW / 120 kW	300 mm	6SL3162-1AH00-0AA0	Clamps
Motor Module	3 ... 18 A 2 x 3 A ... 2 x 9 A	50 mm	Integrated in the motor connector	
	18 A (compact) 2 x 1.7 A ... 2 x 5 A	75 mm		
	30 A and 2 x 18 A	100 mm	Included in the scope of delivery	KLBÜ CO4 ¹⁾
	45 A and 60 A	150 mm	6SL3162-1AF00-0BA1	KLBÜ CO1 ¹⁾ for the brake cable KLBÜ CO4 ¹⁾ for the motor cable
	85 A	200 mm	6SL3162-1AH01-0BA0	KLBÜ CO1 ¹⁾ for brake cable clamps for motor cable
	132 A and 200 A	300 mm	6SL3162-1AH00-0AA0	KLBÜ CO1 ¹⁾ for brake cable clamps for motor cable

1) Shield connection terminal, Weidmüller Company

11.1 Shield connecting plates for power supply and motor cables

Table 11-4 Shield connection for liquid-cooled components

Component	Power	Total width of component	Shield connection plate	Recommended shield connection
Line Module	120 kW	300 mm	6SL3162-1AH00-0AA0	Clamps
Motor Module	200 A	300 mm	6SL3162-1AH00-0AA0	KLBÜ CO1 ¹⁾ for brake cable clamps for motor cable

¹⁾ Shield connection terminal, Weidmüller Company

11.1.3 Overview examples

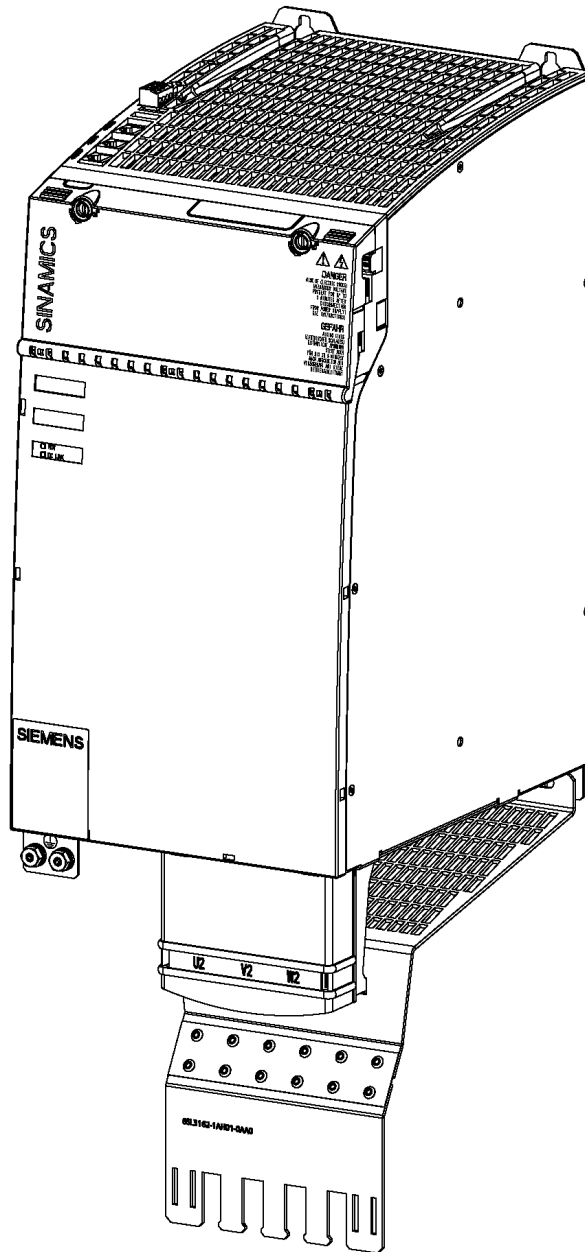

Figure 11-1 Shield connecting plate for a 200 mm module with internal air cooling

11.1 Shield connecting plates for power supply and motor cables

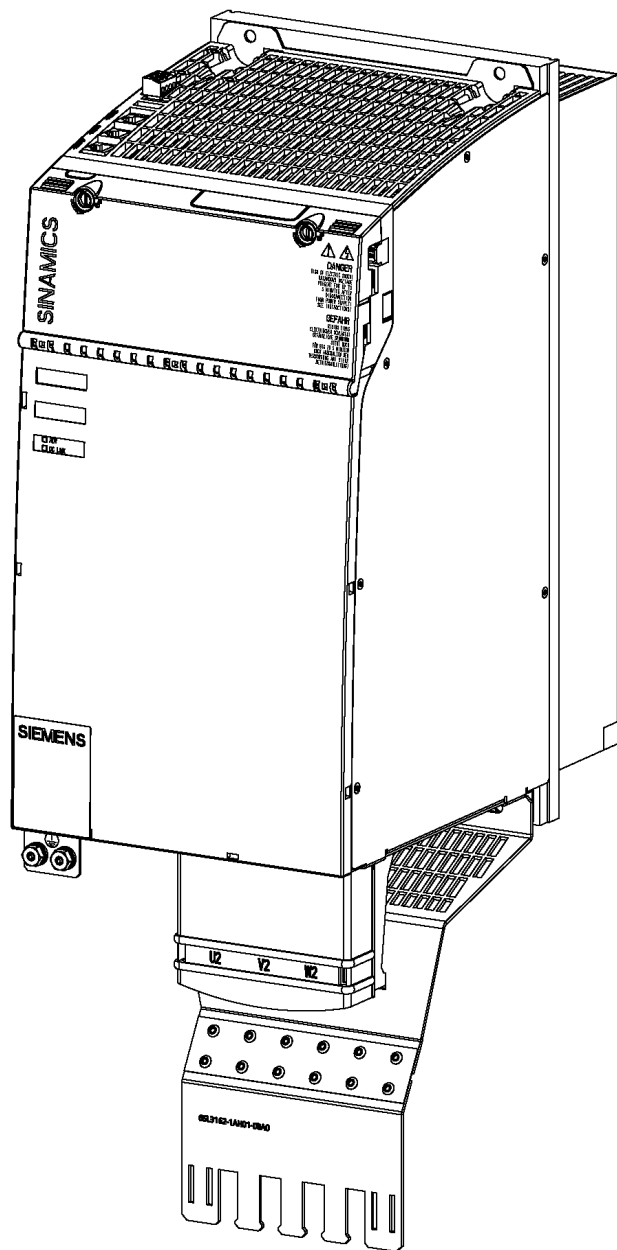

Figure 11-2 Shield connecting plate for a 200 mm module with external air cooling

11.1 Shield connecting plates for power supply and motor cables

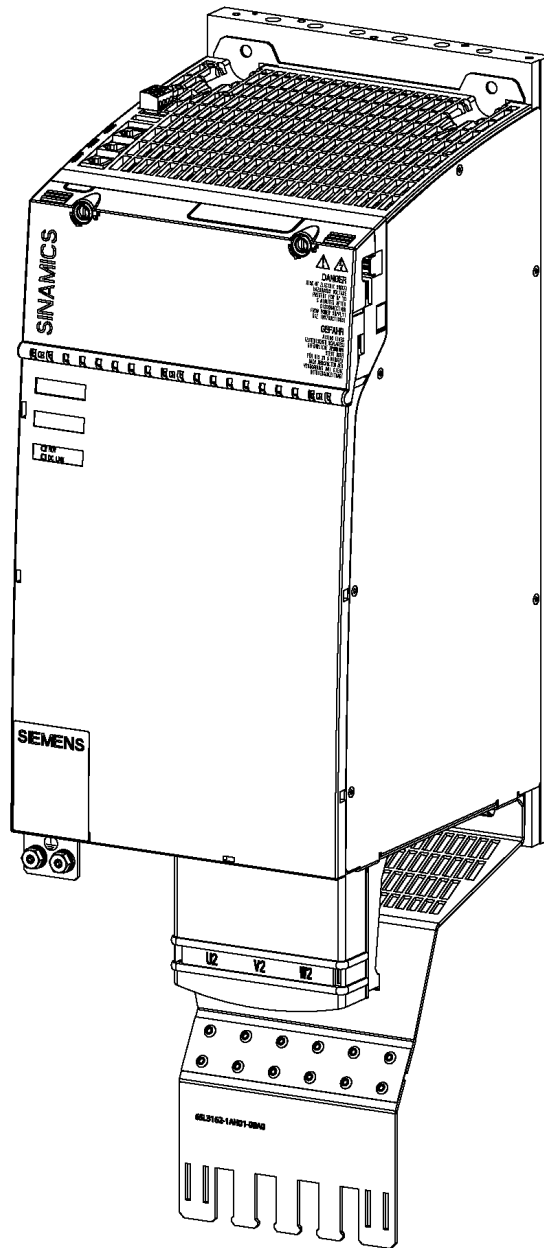

Figure 11-3 Shield connecting plate for a 200 mm module with a cold plate

11.1 Shield connecting plates for power supply and motor cables

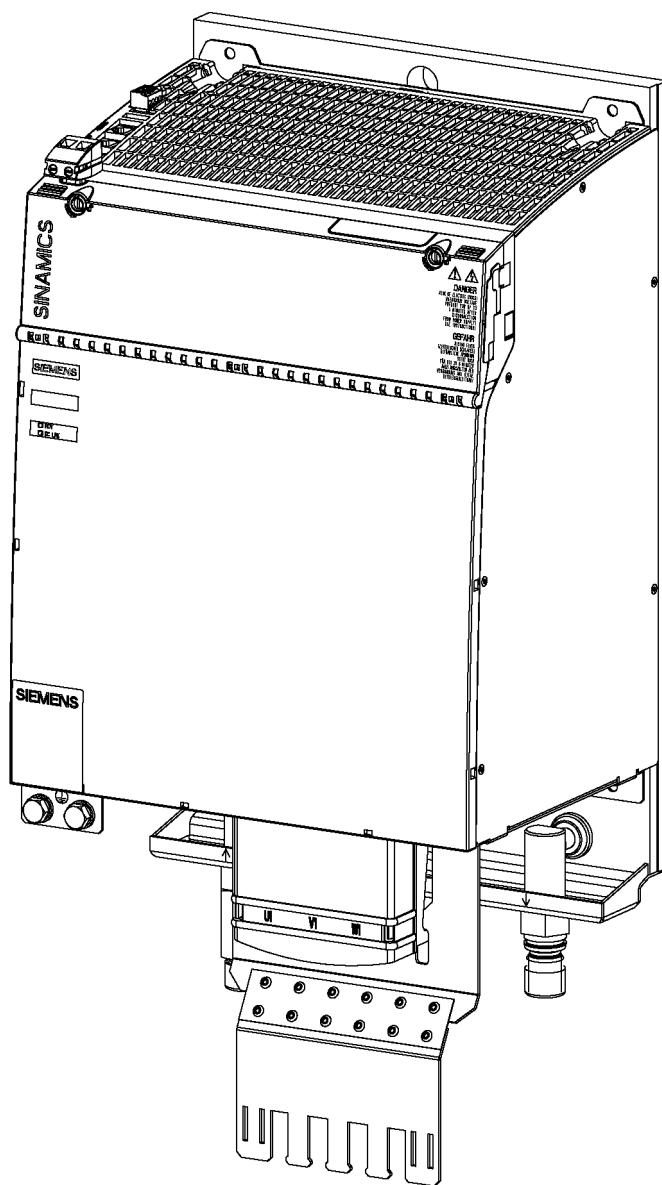

Figure 11-4 Shield connecting plate on a 300 mm module Liquid Cooled

11.1 Shield connecting plates for power supply and motor cables

11.1.4 Dimension drawings

11.1.4.1 Line Modules and Motor Modules with internal air cooling

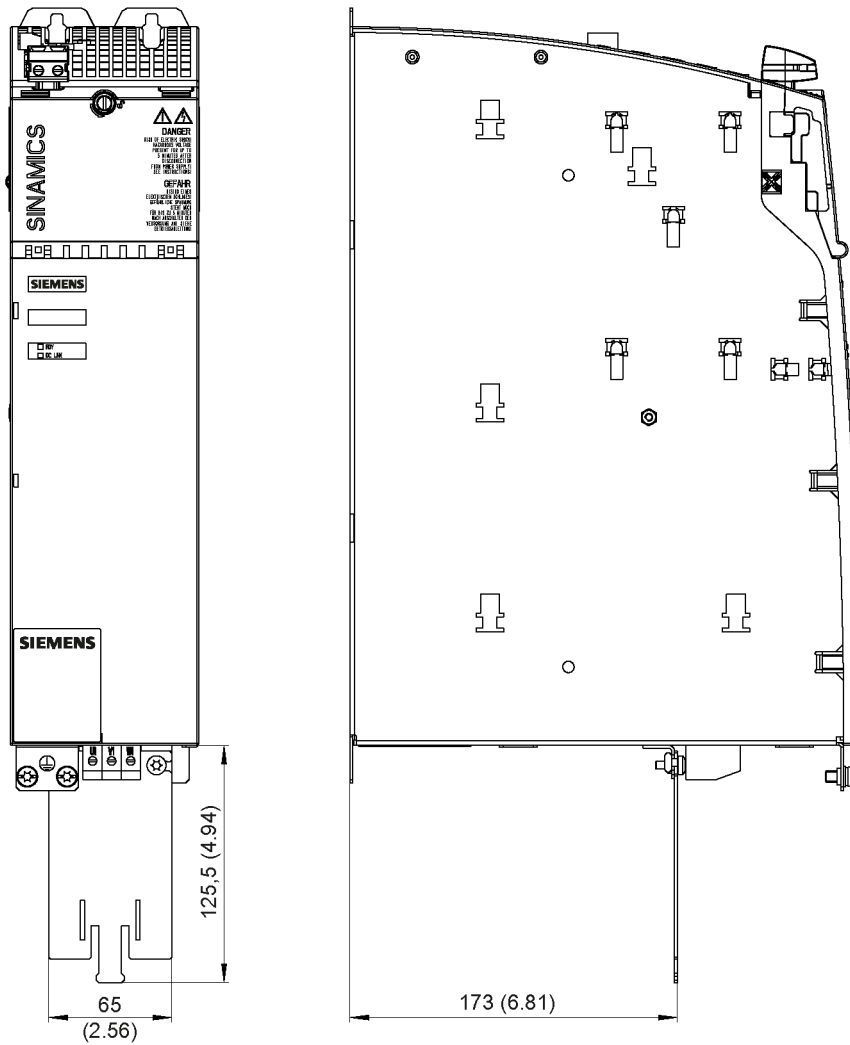

Figure 11-5 Dimension drawing of shield connecting plate on a 100 mm component with internal air cooling, all dimensions in mm and (inches)

11.1 Shield connecting plates for power supply and motor cables

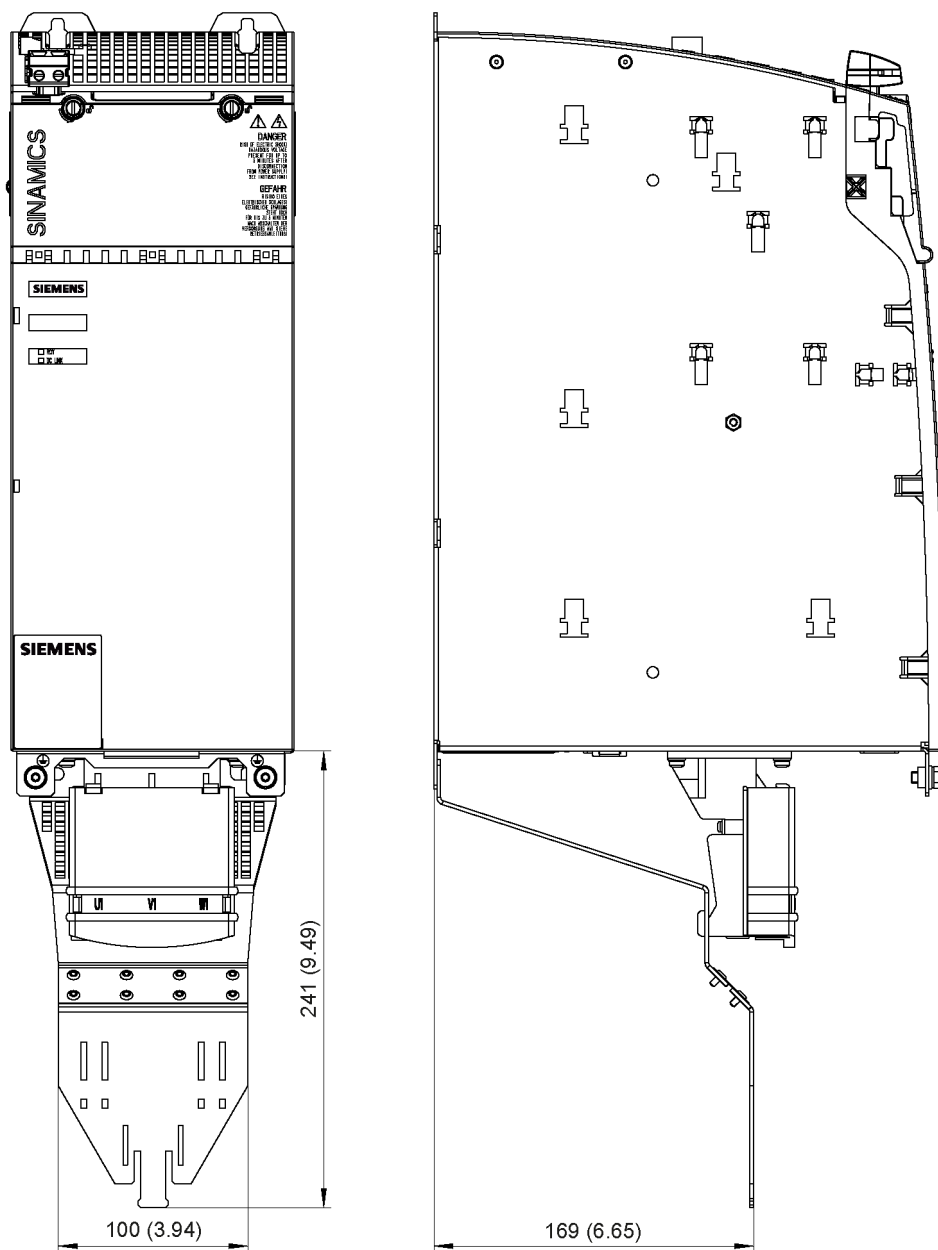

Figure 11-6 Dimension drawing of shield connecting plate on a 150 mm component with internal air cooling, all dimensions in mm and (inches)

11.1 Shield connecting plates for power supply and motor cables

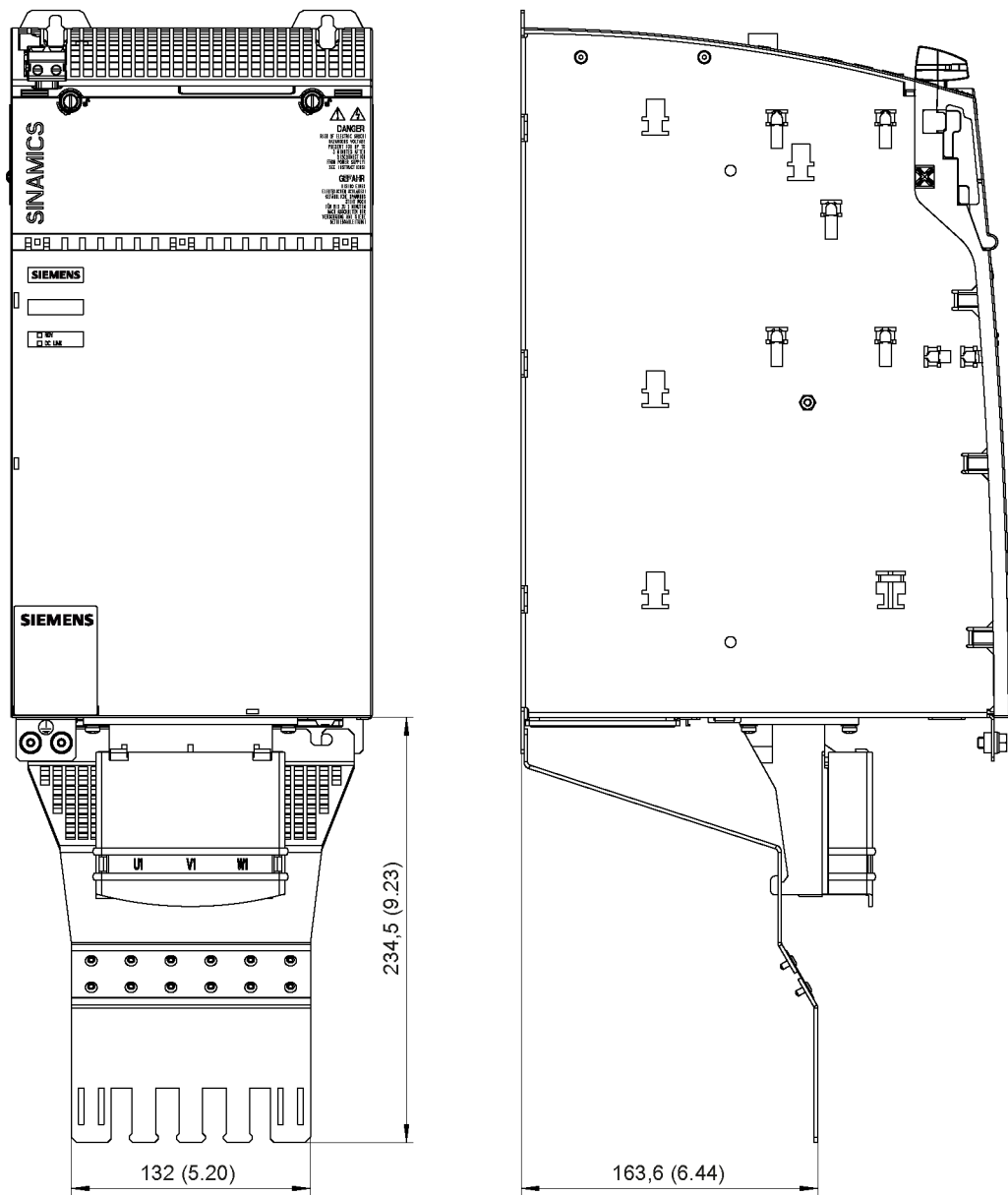

Figure 11-7 Dimension drawing of shield connecting plate on a 200 mm component with internal air cooling, all dimensions in mm and (inches)

11.1 Shield connecting plates for power supply and motor cables

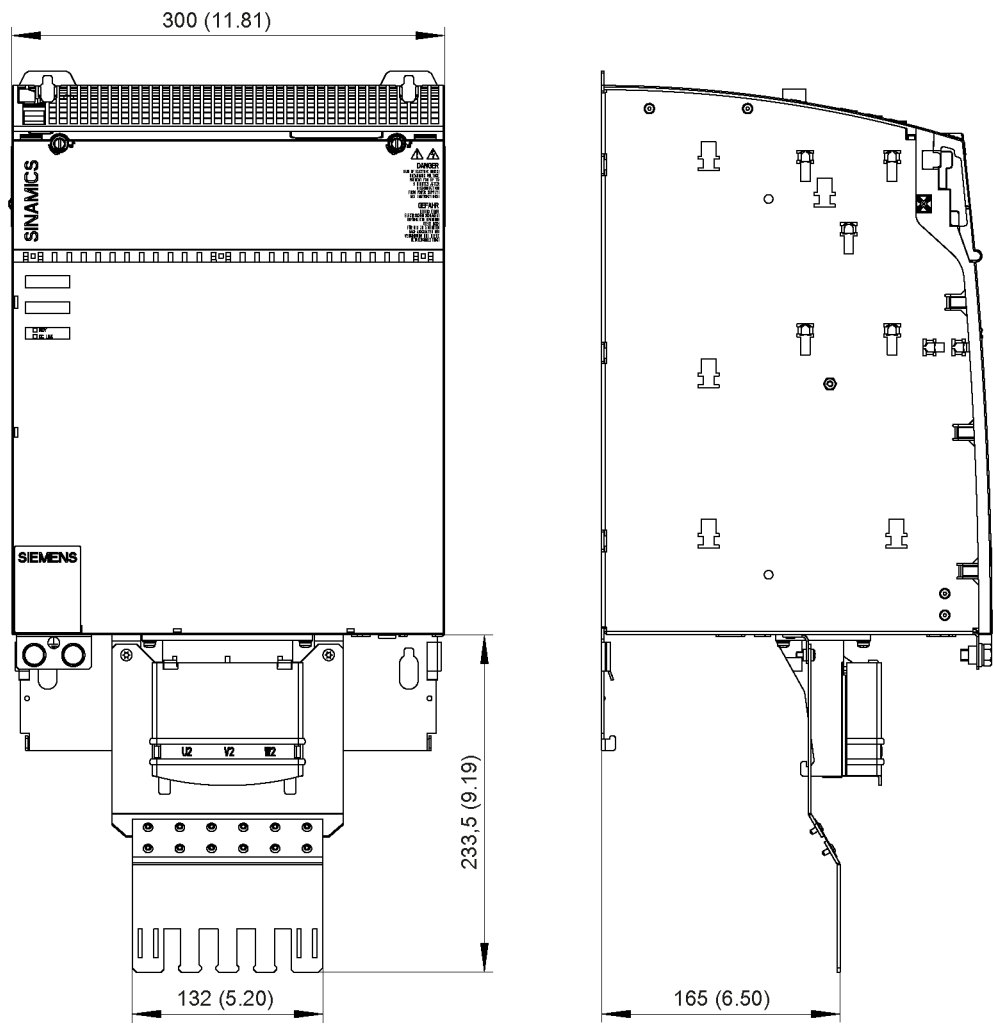

Figure 11-8 Dimension drawing of shield connecting plate on a 300 mm component with internal air cooling, all dimensions in mm and (inches)

11.1.4.2 Line Modules and Motor Modules with external air cooling

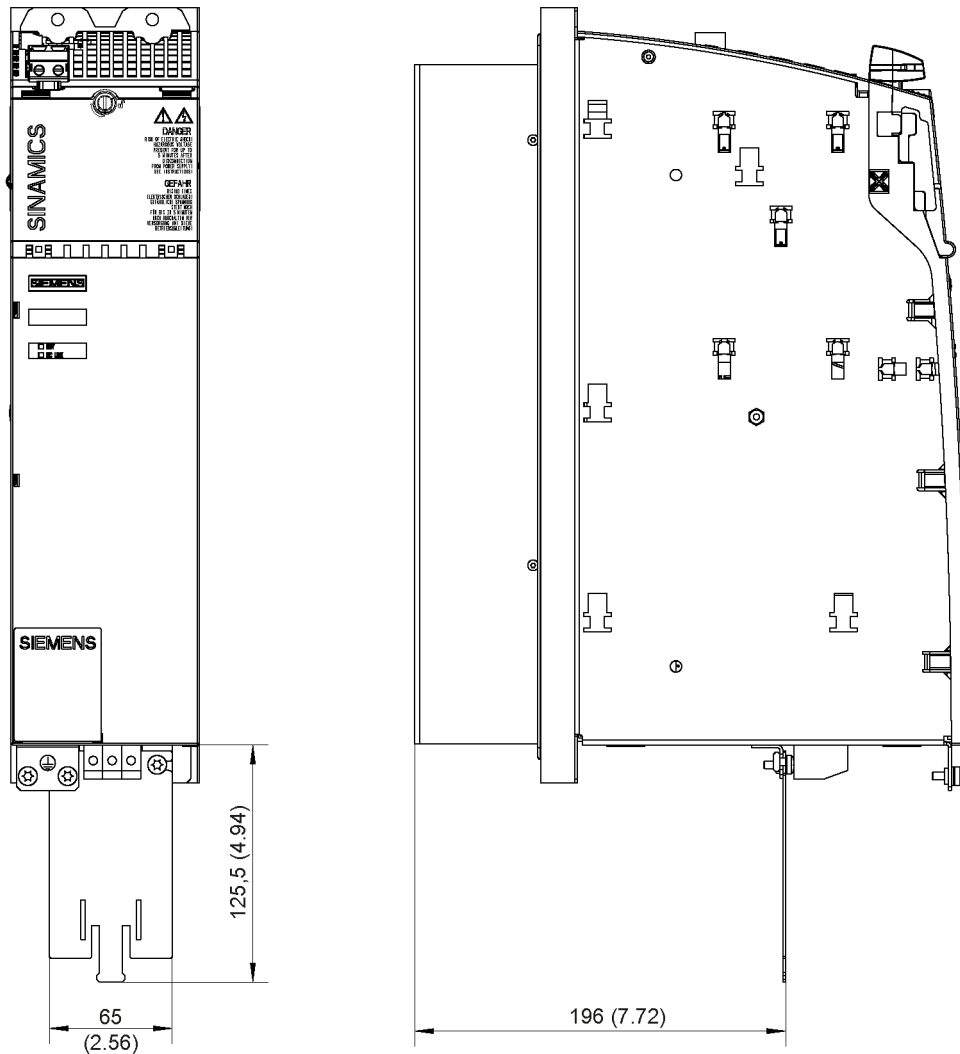

Figure 11-9 Dimension drawing of shield connecting plate on a 100 mm component with external air cooling, all dimensions in mm and (inches)

11.1 Shield connecting plates for power supply and motor cables

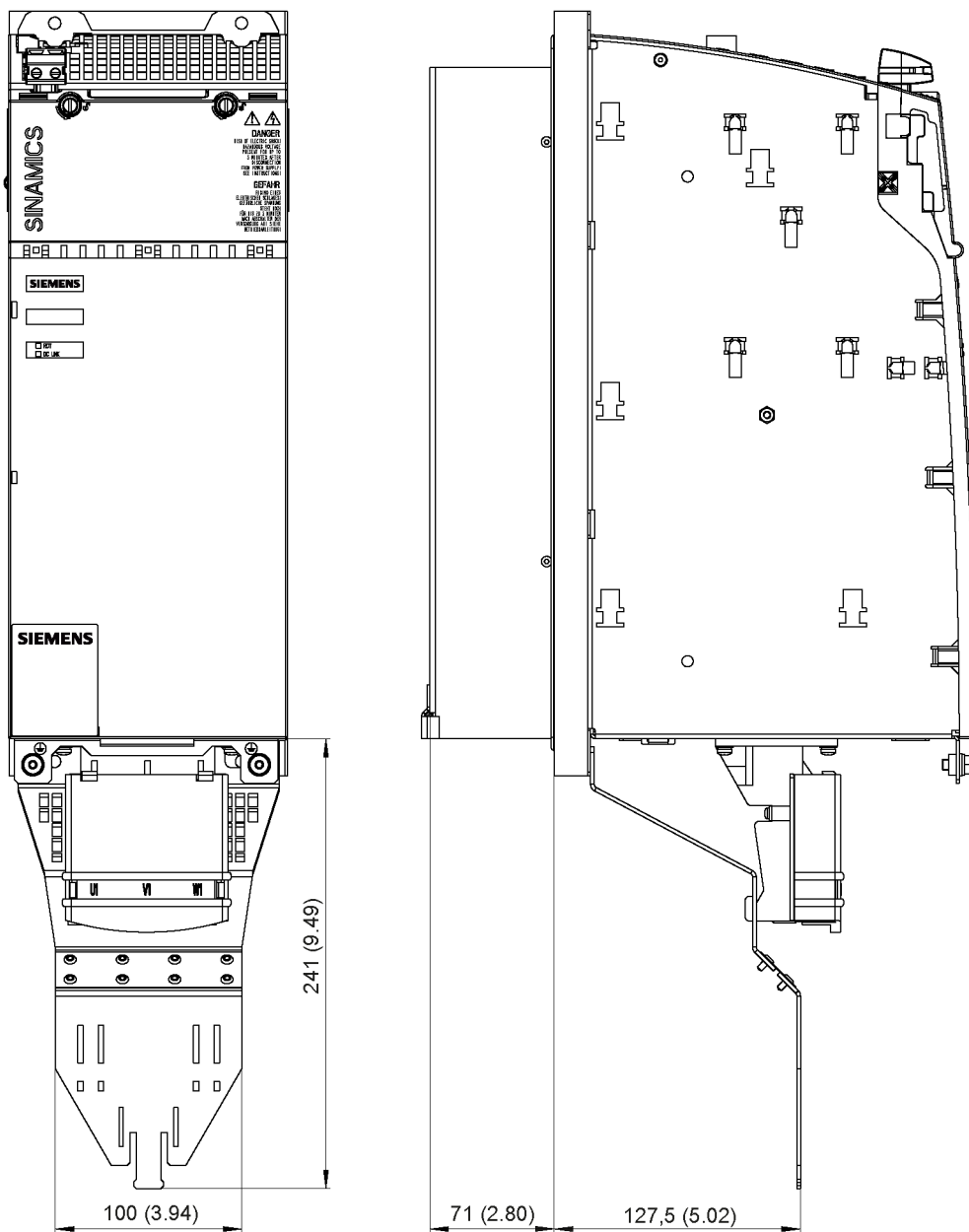

Figure 11-10 Dimension drawing of shield connecting plate on a 150 mm component with external air cooling, all dimensions in mm and (inches)

11.1 Shield connecting plates for power supply and motor cables

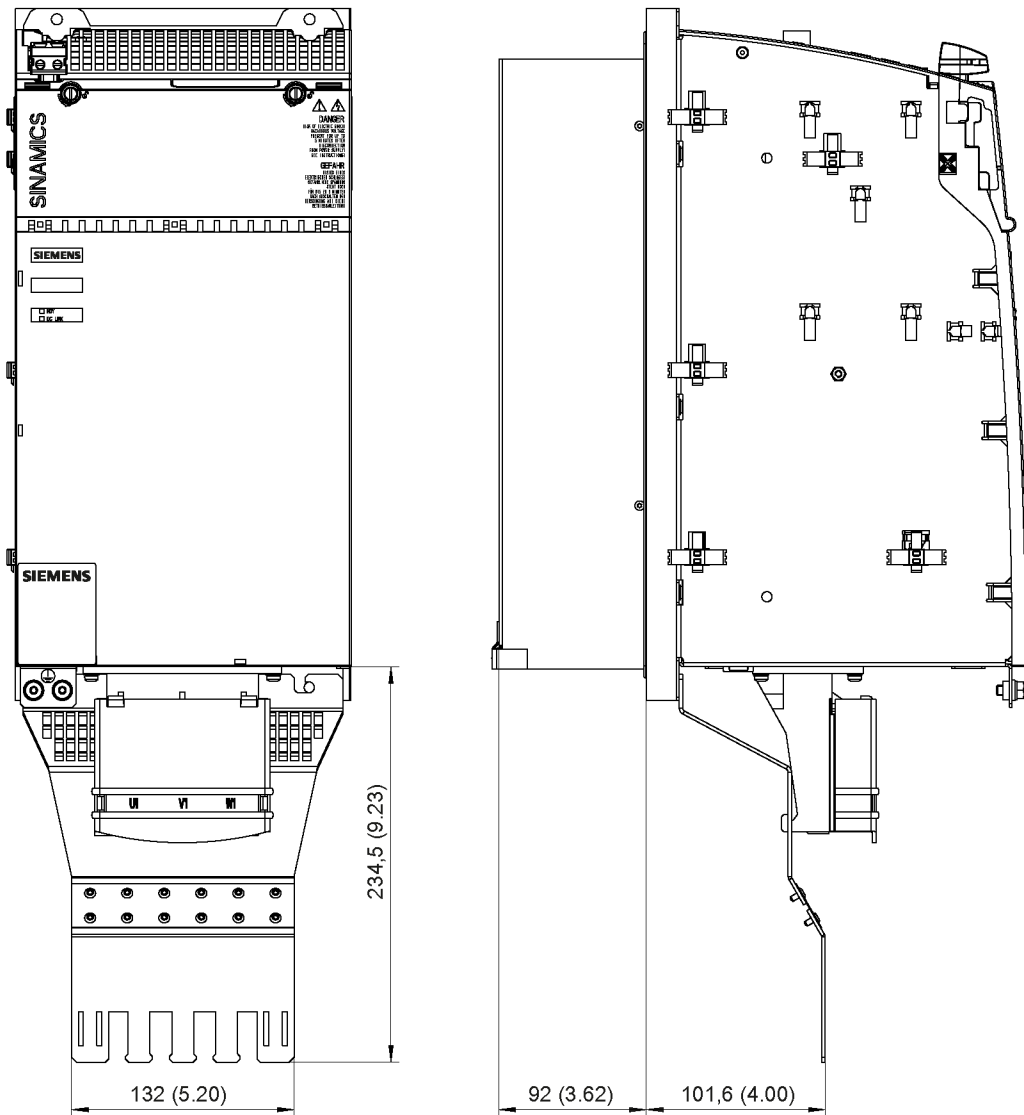

Figure 11-11 Dimension drawing of shield connecting plate on a 200 mm component with external air cooling, all dimensions in mm and (inches)

11.1 Shield connecting plates for power supply and motor cables

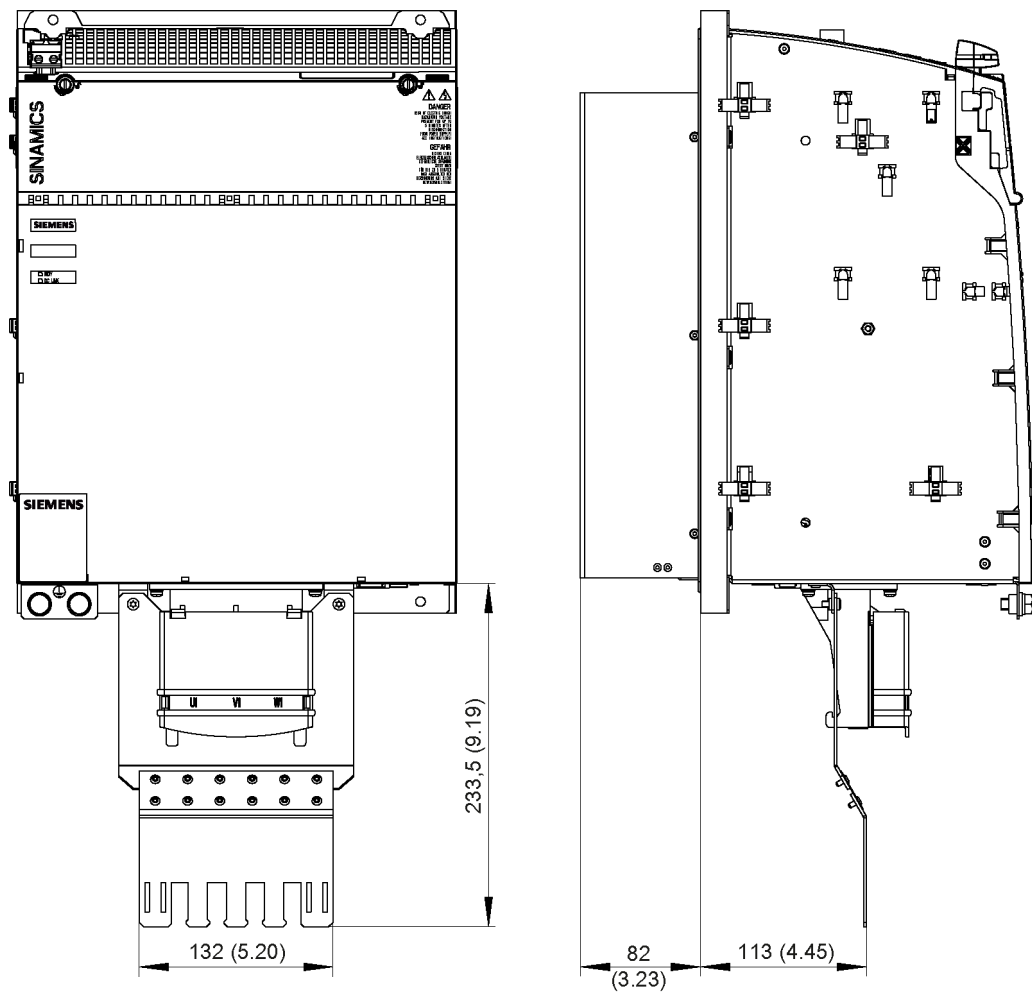

Figure 11-12 Dimension drawing of shield connecting plate on a 300 mm component with external air cooling, all dimensions in mm and (inches)

11.1.4.3 Line Modules and Motor Modules with cold plate

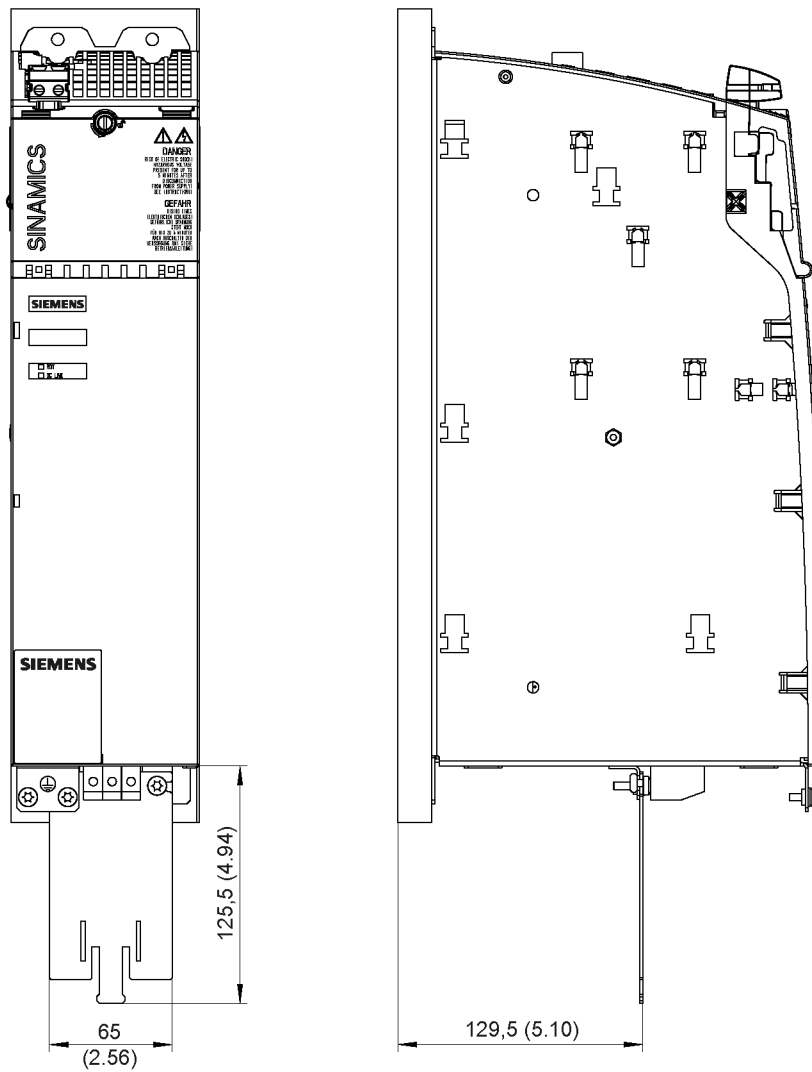

Figure 11-13 Dimension drawing of shield connecting plate on a 100 mm component with cold plate, all dimensions in mm and (inches)

11.1 Shield connecting plates for power supply and motor cables

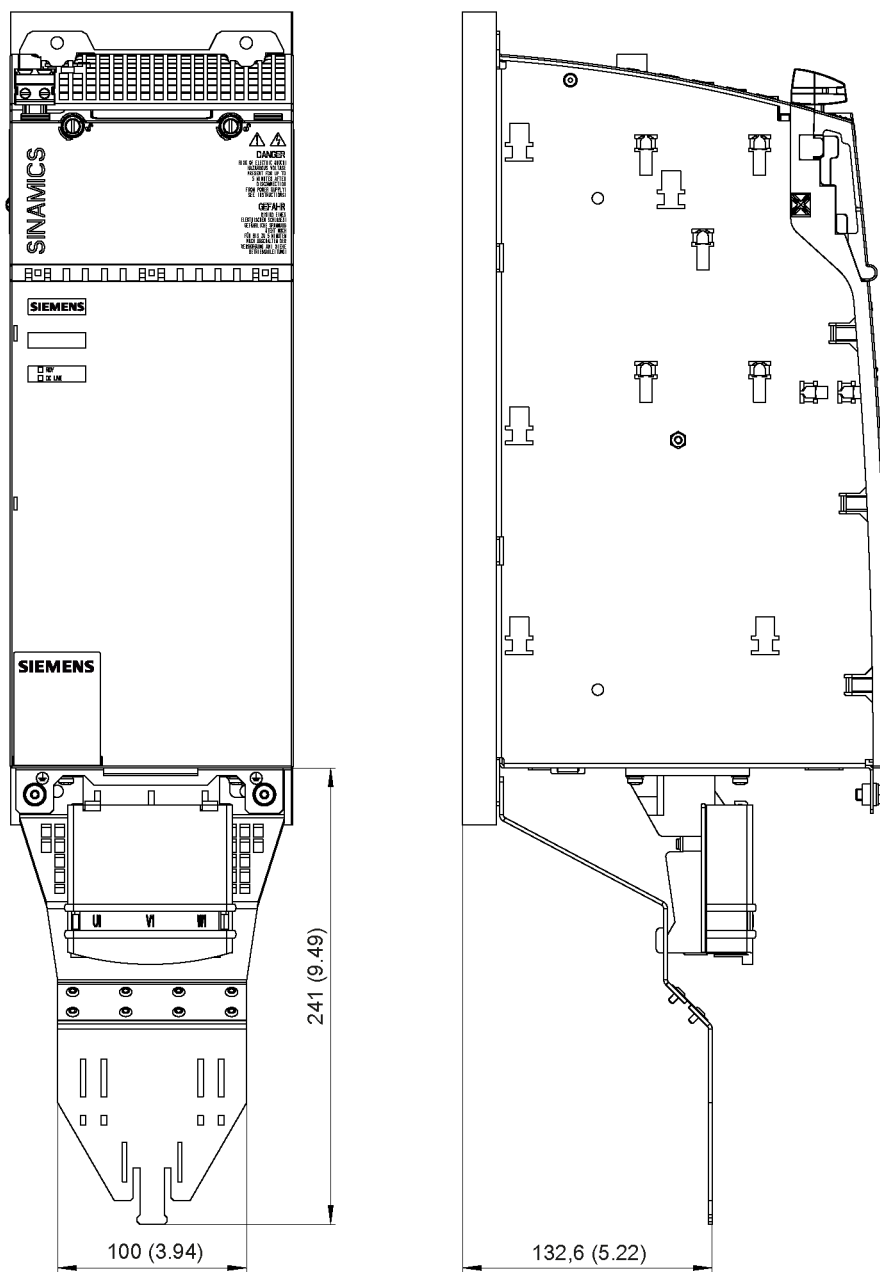

Figure 11-14 Dimension drawing of shield connecting plate on a 150 mm component with cold plate, all dimensions in mm and (inches)

11.1 Shield connecting plates for power supply and motor cables

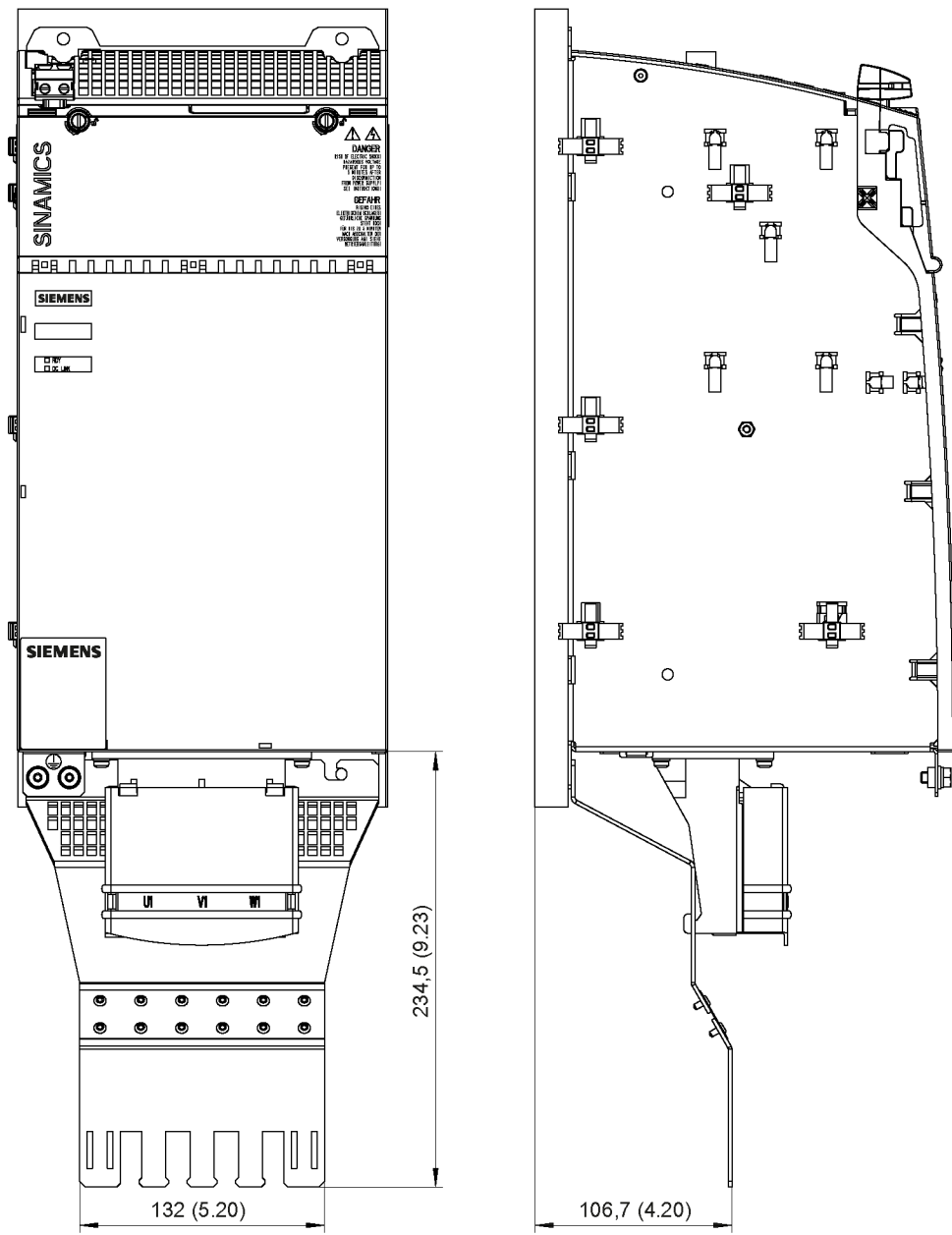

Figure 11-15 Dimension drawing of shield connecting plate on a 200 mm component with cold plate, all dimensions in mm and (inches)

11.1 Shield connecting plates for power supply and motor cables

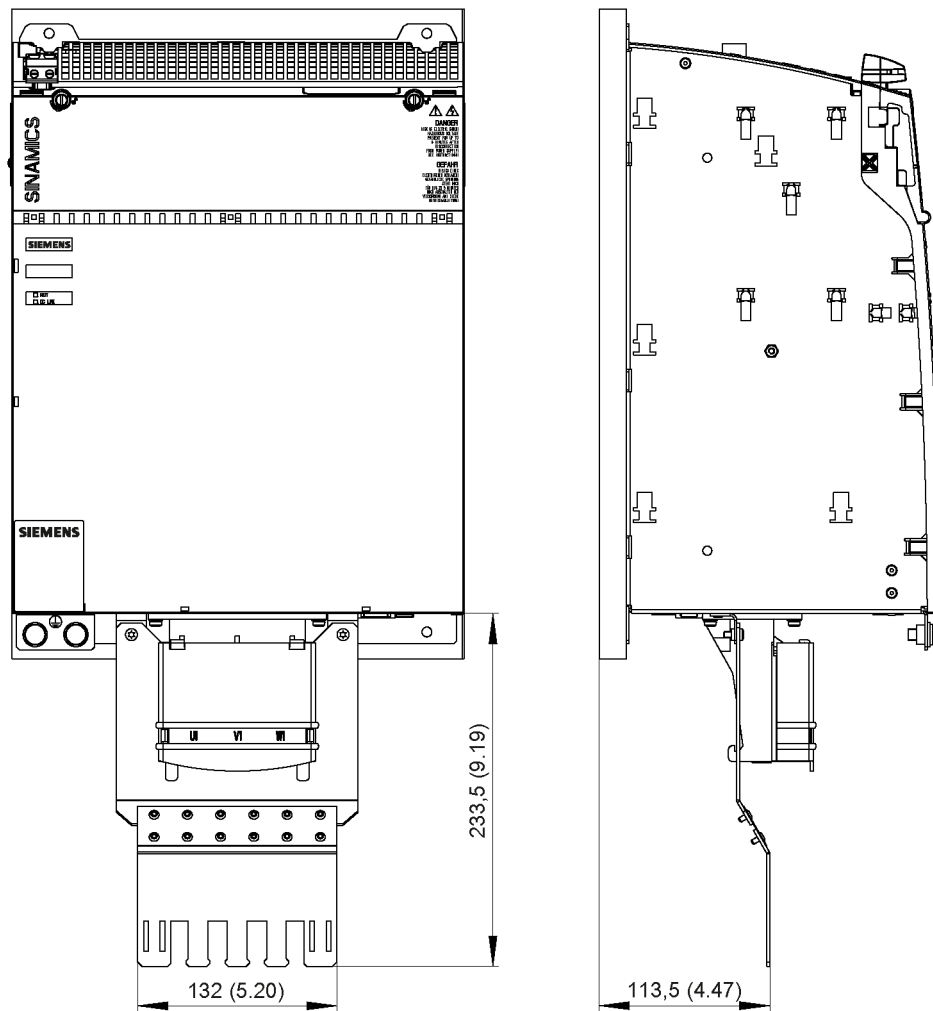

Figure 11-16 Dimension drawing of shield connecting plate on a 300 mm component with cold plate, all dimensions in mm and (inches)

11.1.4.4 Line Modules and Motor Modules, Liquid Cooled

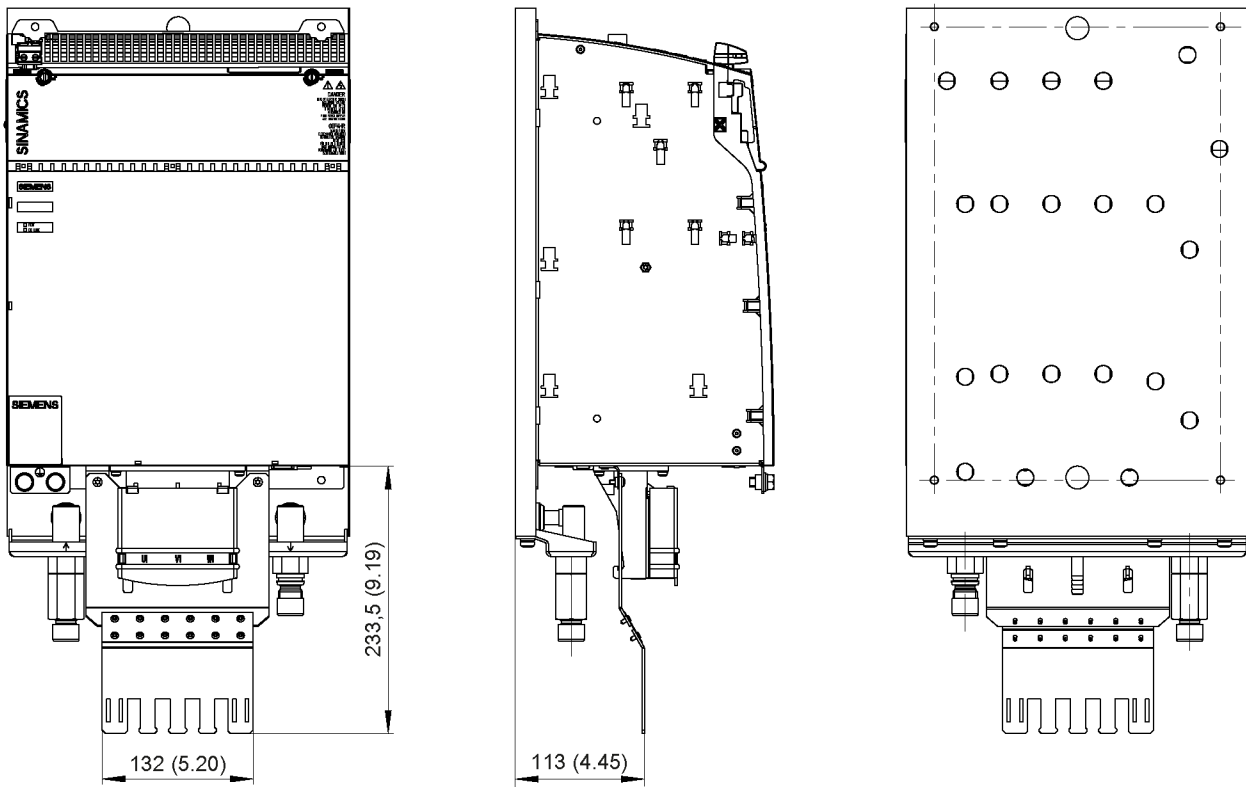

Figure 11-17 Dimension drawing of shield connecting plate on a 300 mm Liquid Cooled component, all dimensions in mm and (inches)

11.1.4.5 Active Interface Modules

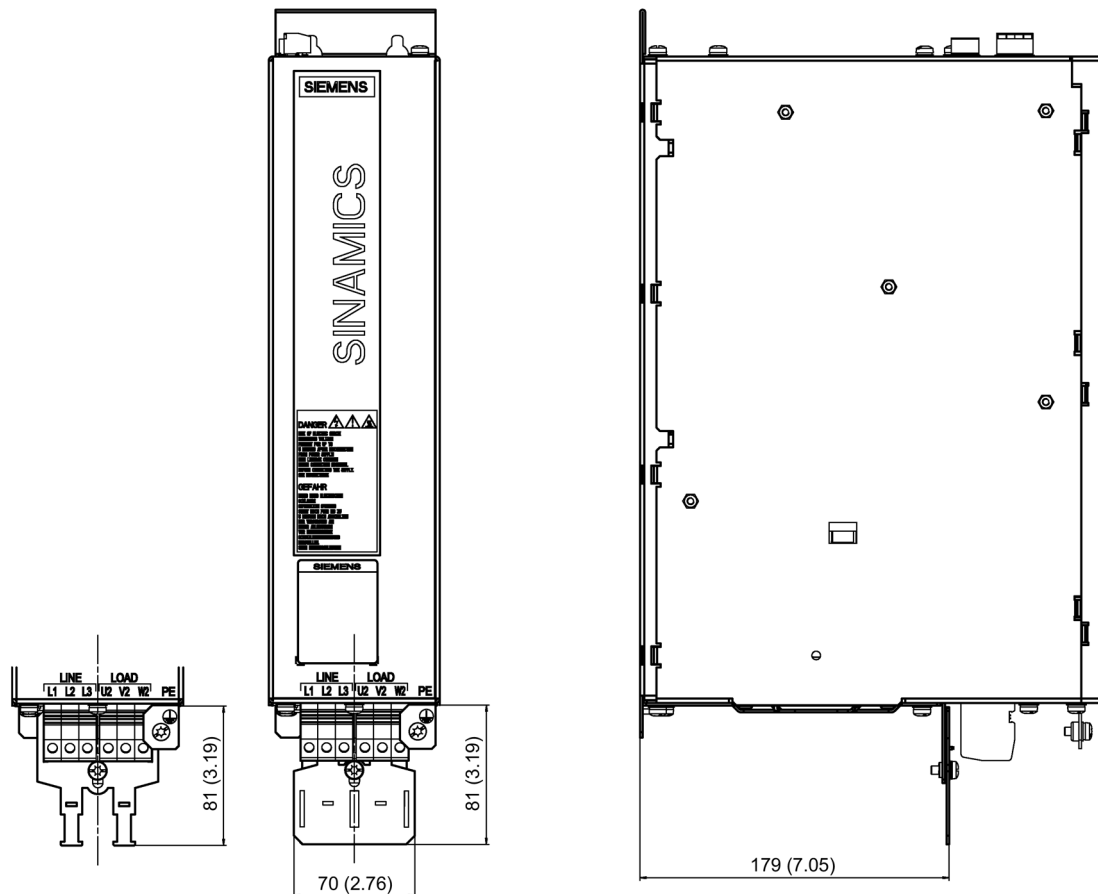

Figure 11-18 Dimension drawing of shield connecting plate on the 16 kW Active Interface Module, all dimensions in mm and (inches)

11.1 Shield connecting plates for power supply and motor cables

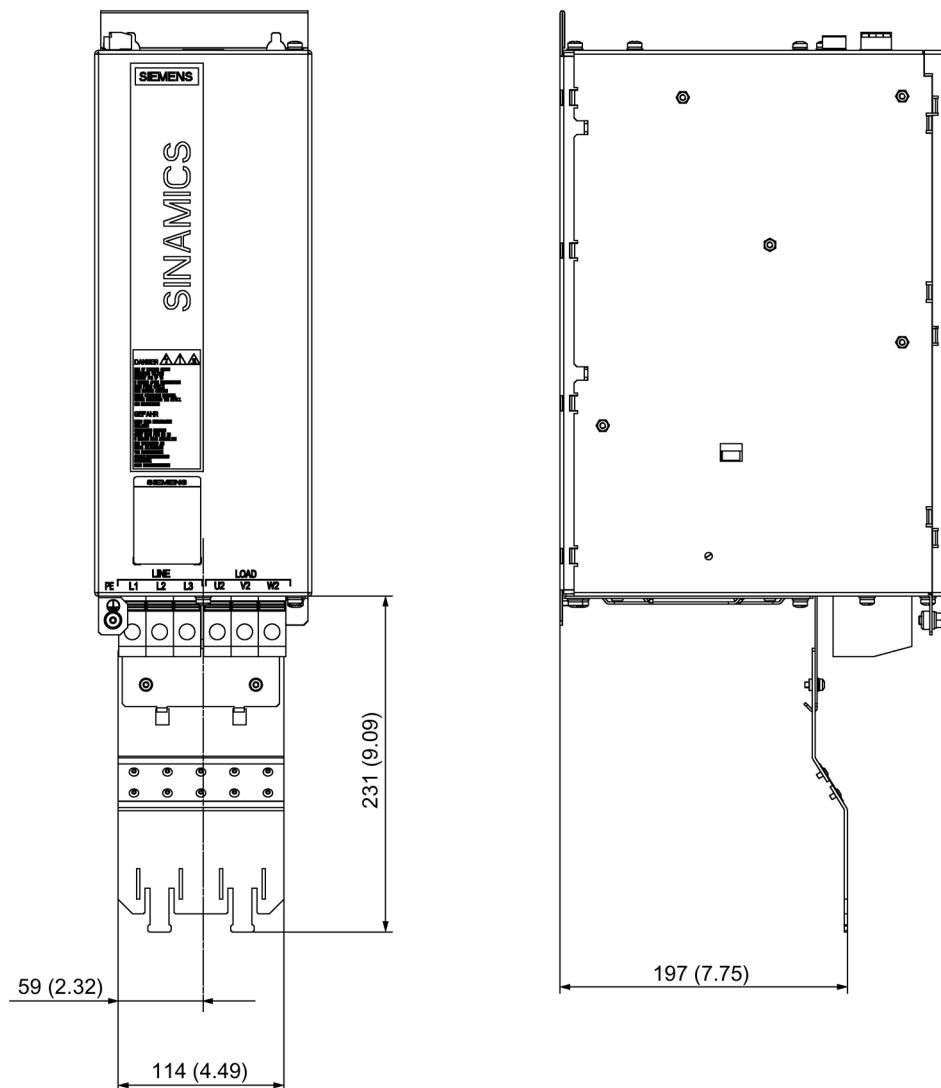

Figure 11-19 Dimension drawing of shield connecting plate on the 36 kW Active Interface Module, all dimensions in mm and (inches)

11.1 Shield connecting plates for power supply and motor cables

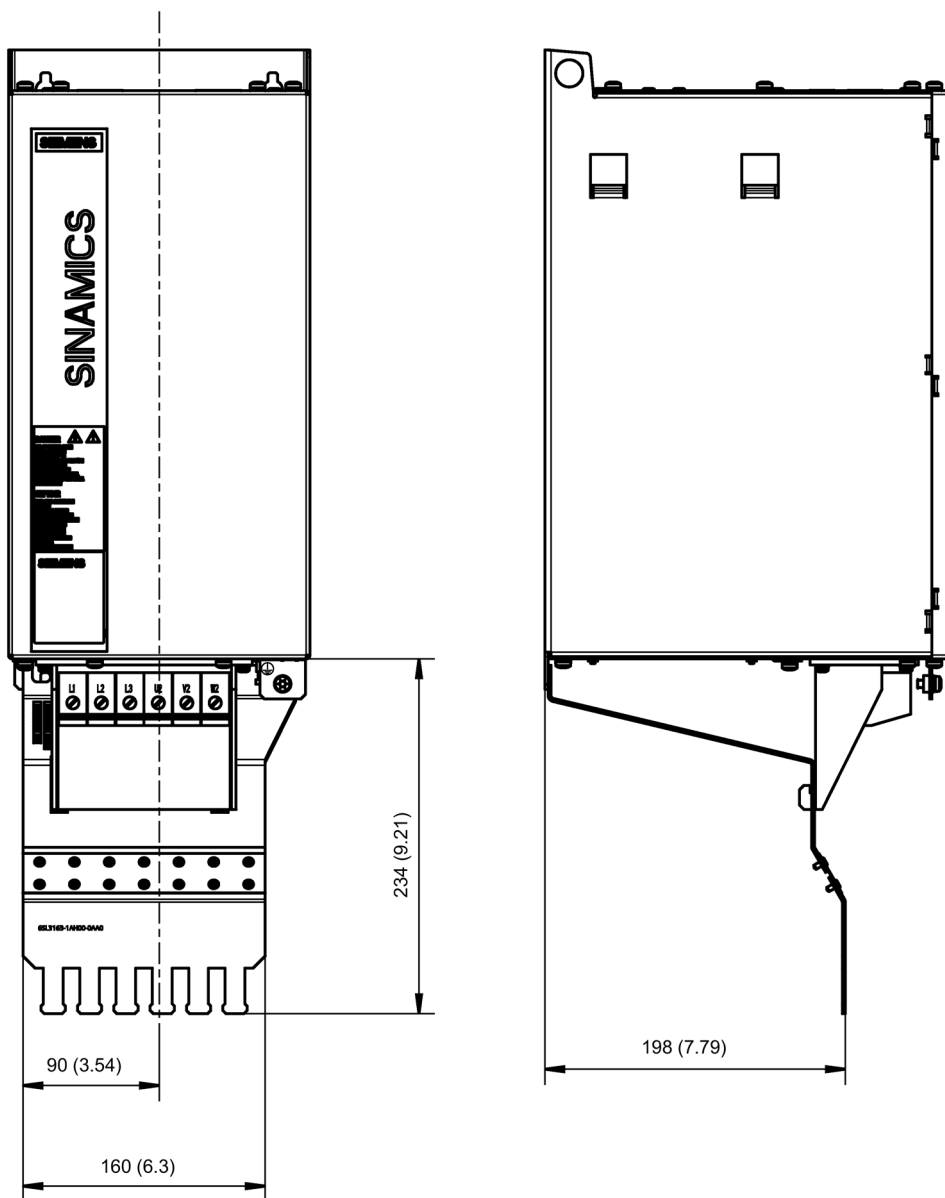

Figure 11-20 Dimension drawing of shield connecting plate on the 55 kW Active Interface Module, all dimensions in mm and (inches)

11.1 Shield connecting plates for power supply and motor cables

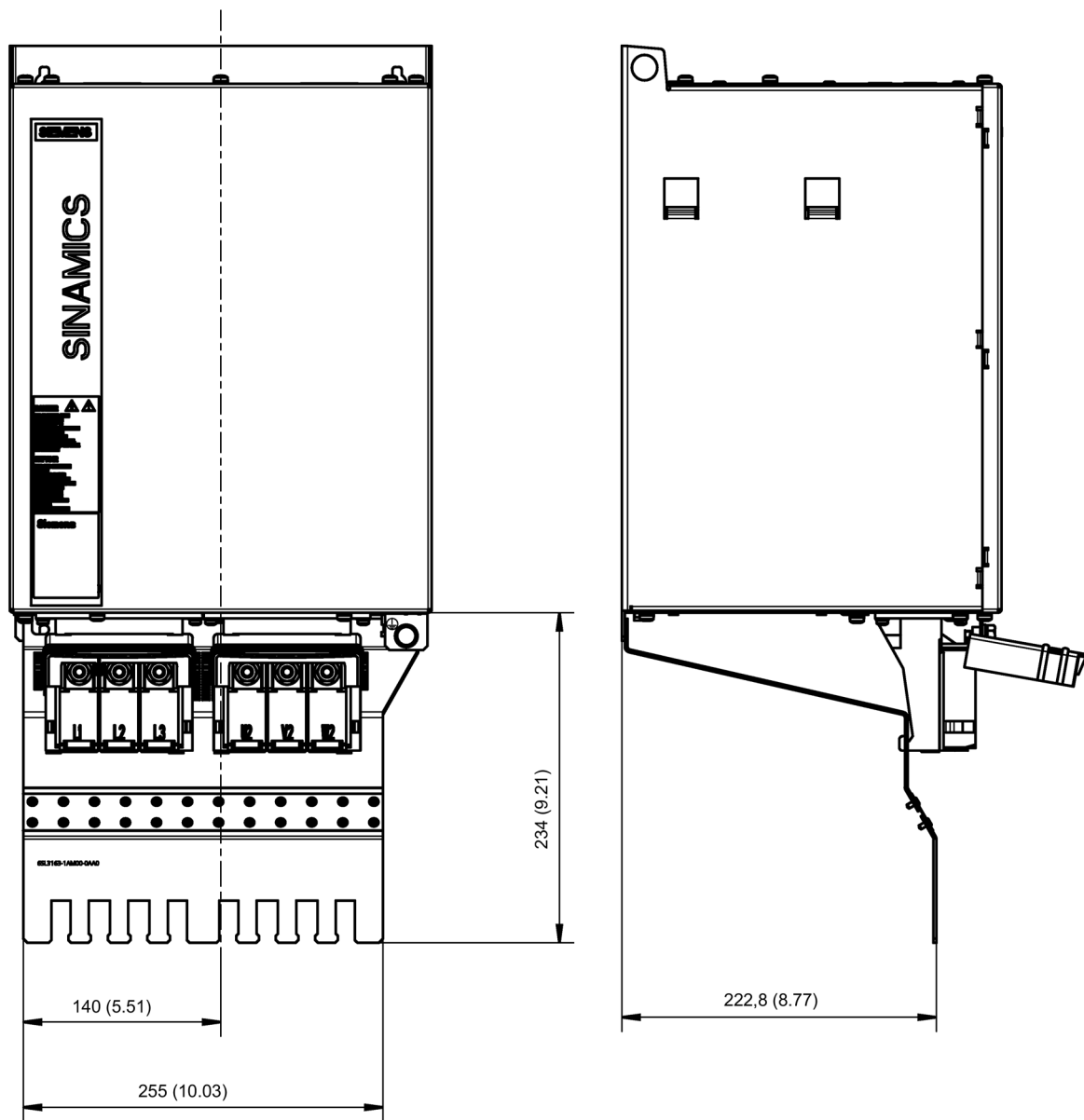

Figure 11-21 Dimension drawing of shield connecting plate on the 80 and 120 kW Active Interface Module, all dimensions in mm and (inches)



11.1.5 Installation

Example 1: 100 mm wide components with internal air cooling

Tools required:

- Torx screwdriver T25 for shield connecting plate

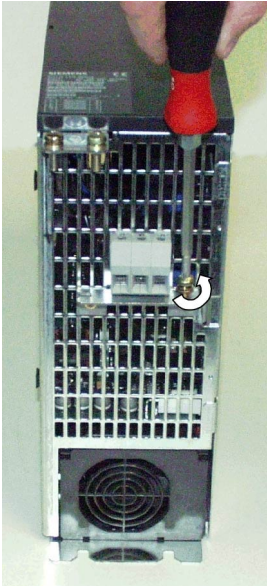
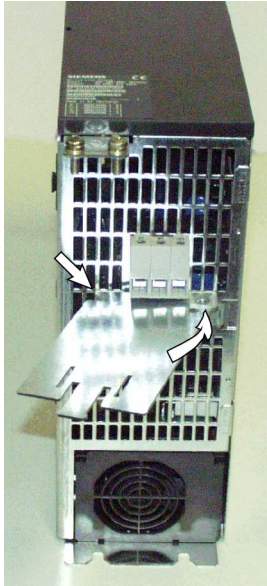
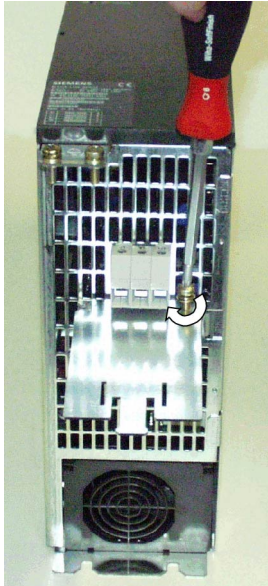
Table 11- 5 Installing the shield connecting plate to a 100 mm wide component (here with internal air cooling)

			
<p>1. Remove the screw.</p>	<p>2. Engage the shield connecting plate.</p>	<p>3. Tighten the shield connecting plate. Tightening torque: 3 Nm (26.6 lbf in)</p>	<p>Result: Installed shield connecting plate</p>

11.1 Shield connecting plates for power supply and motor cables

Example 2: 200 mm wide component with internal air cooling

Tools required:

- Screwdriver for fixing screws used

Table 11- 6 Installing the shield connecting plate to a 200 mm wide component (here with internal air cooling)

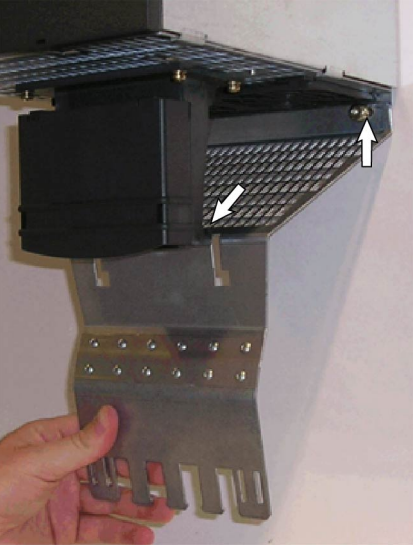
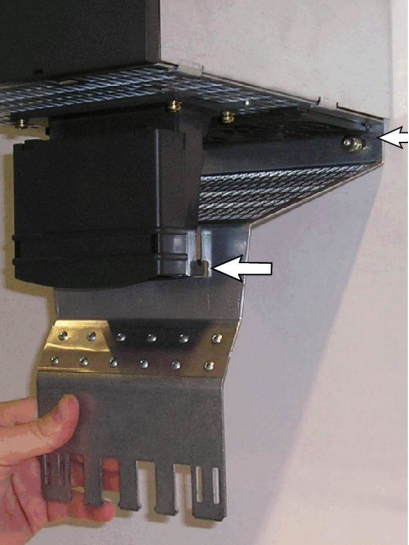
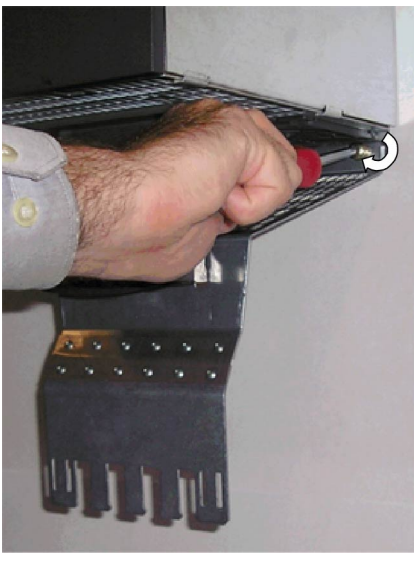
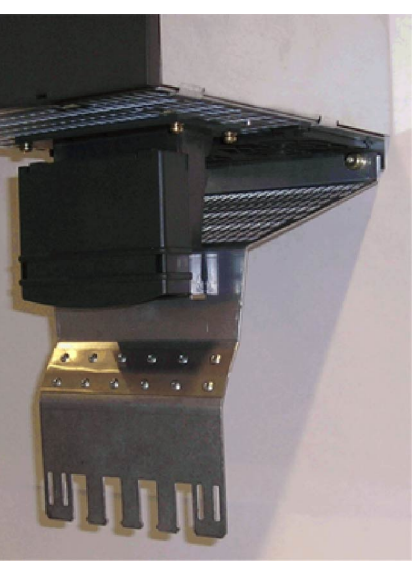
		
<p>1. Loosen the lower screw.</p>	<p>2. Engage the shield connecting plate into the screws and at the line/motor connection</p>	<p>3. Attach the shield connecting plate by pulling it to the left</p>
		
<p>4. Tighten the shield connecting plate. Tightening torque: 6 Nm (53.1 lbf in)</p>	<p>Result: Installed shield connecting plate</p>	

11.1 Shield connecting plates for power supply and motor cables

Example 3: 300 mm wide component with internal air cooling

Tools required:

- Torx screwdriver T25 for shield connecting plate

Table 11-7 Installing the shield connecting plate to a 300 mm wide component (here with internal air cooling)

<p>1. Remove the screw.</p>	<p>2. Engage the shield connecting plate into the line/motor connection</p>
<p>3. Tighten the shield connecting plate. Tightening torque: 3 Nm (26.6 lbf in)</p>	<p>Result: Installed shield connecting plate</p>

11.1.6 Connecting the power cables

Example 1: 100 mm wide components with internal air cooling

Required tools:

- Torx screwdriver T25 for protective conductor connection (Torx slot)
- Flat-bladed screwdriver size 4 for power cables
- Flat-bladed screwdriver for hose clamp

Table 11- 8 Connection of the power cable for a 100 mm wide component (here with internal air cooling)

<p>1. Attach the protective conductor. Tightening torque: 3 Nm (26.6 lbf in)</p>	<p>2. Attach the power cable. Tightening torque: 1.8 Nm (15.9 lbf in)</p>	<p>3. Tighten the hose clamp at the shield connecting plate.</p>	<p>Result: The power cable is connected.</p>

11.1 Shield connecting plates for power supply and motor cables

Example 2: 200 mm wide component with internal air cooling

Required tools:

- Torx screwdriver T25 for protective conductor connection (Torx slot)
- (Torque) wrench M8 for power cables
- Flat-bladed screwdriver for hose clamp

Table 11-9 Connection of the power cable for a 200 mm wide component (here with internal air cooling)

<p>1. Release and open the cover of the terminal strip.</p>	<p>2. Remove the M8 nuts.</p>	<p>3. Attach the protective conductor and the power cable. Tightening torque: 13 Nm (115 lbf in)</p>
<p>4. Adapt a restrictor collar (using a suitable tool) for the touch protection.</p>	<p>5. Push on the reduction collar.</p>	<p>6. Tighten the hose clamp at the shield connecting plate.</p>

11.2 Releasing the DC link protective cover

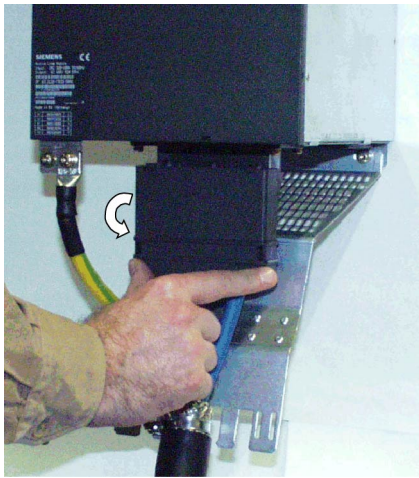

7. Close the cover of the terminal strip.

11.2 Releasing the DC link protective cover

The protective covers for the DC link on the SINAMICS S120 components have an interlocking mechanism, which must be opened using a flat bladed screwdriver (1 x 5.5).

Table 11- 10 Opening the protective cover for the DC link using a screwdriver

<p>1. Protective cover with interlocking mechanism</p>	<p>2. To open the protective cover, use a screwdriver to slightly turn the interlocking screw in the direction of the arrow (counter-clockwise)</p>	<p>3. Opened protective cover</p>



To lock, press the protective cover back on until you hear the interlock engage.

11.3 Reinforced DC link busbars

11.3.1 Description

Reinforced DC link busbars are available for 50 mm and 100 mm wide components of the Booksize and Booksize Compact series. They are used to increase the current carrying capacity of the components used to conduct the DC-link current from 100 A to 150 A.

Table 11- 11 Reinforced DC link busbars

	
Reinforced DC link busbar for 50 mm wide components	Reinforced DC link busbar for 100 mm wide components
Article number: 6SL3162-2DB00-0AA.	Article number: 6SL3162-2DD00-0AA.

Note

Installation

- The busbar must always be mounted with the longer narrow edge on the left (see above).
- Reinforced DC link busbars must not be installed at the left-hand module in the drive line-up.

Note

DC-link rectifier adapter / DC-link adapter

Note the following when using reinforced DC link busbars:

- It is not possible to use a DC link rectifier adapter!
- Use the 2-hole adapter as DC link adapter (Article number: 6SL3162-2BM10-0AA0).

Note

No use of 6 mm DC link bridges

The use of 6 mm DC link bridges (article number: 6SL3162-2BB00-0AA0) will not lead to an increased current carrying capacity for the modules ..AA3 / ..AA4.

Notes on configuration and arrangement of the components in the drive line-up can be found in the Chapter, Arrangement of components and devices (Page 648).

11.3.2 Safety instructions for reinforced DC link busbars



	WARNING
	Electric shock due to the residual charge of the DC-link capacitors
	Because of the DC link capacitors, a hazardous voltage is present for up to 5 minutes after the power supply has been switched off.
	Contact with live parts can result in death or serious injury.
	<ul style="list-style-type: none"> • Do not open the protective cover of the DC link until 5 minutes have elapsed. • Measure the voltage before starting work on the DCP and DCN DC link terminals.



	WARNING
	Electric shock when the protective cover of the DC link is open
	Contact with live parts can result in death or serious injury.
	<ul style="list-style-type: none"> • Only operate the components with closed protective cover.

	WARNING
	Fire if reinforced DC link busbars are incorrectly installed
	Incorrectly installed reinforced DC link busbars can result in fire with associated smoke. This represents danger to life, and equipment can be damaged.
	<ul style="list-style-type: none"> • Attach the reinforced DC link busbars to the module on the right-hand side of the component only using the original M4x20 screws (the original screws must always be used).



	WARNING
	Electric shock due to incorrectly installed DC link bridges
	Incorrectly installed DC link bridges at the left-hand end of the drive line-up can cause an electric shock.
	<ul style="list-style-type: none"> • For all 50 mm wide modules¹⁾ (exception: Smart Line Module²⁾), remove the DC link bridge, including the screws. Do not tighten the screws without the DC link bridges. • For all components that are 75 mm wide or wider, the DC link bridges may neither be swung over to the left nor removed³⁾.
	¹⁾ For 50 mm wide modules, the DC link bridge cannot be swung inwards.
	²⁾ Smart Line Modules do not have a DC link bridge.
	³⁾ The DC link bridge guarantees the mechanical stability of the DC link busbars.

11.3.3 Dimension drawings

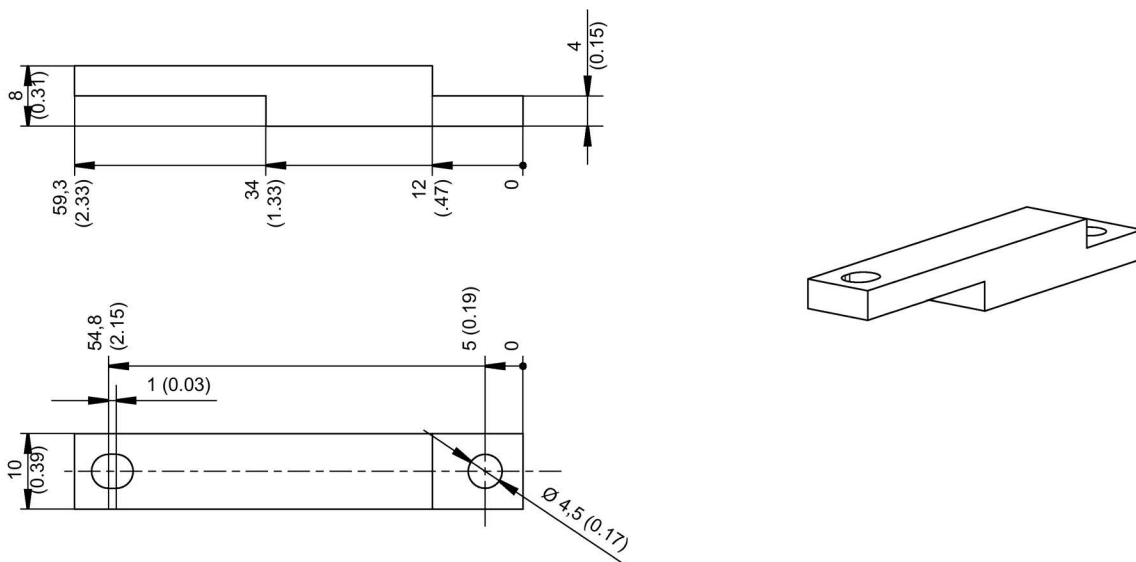

Figure 11-22 Dimension drawing of reinforced DC link busbar 50 mm, all dimensions in mm and (inches)

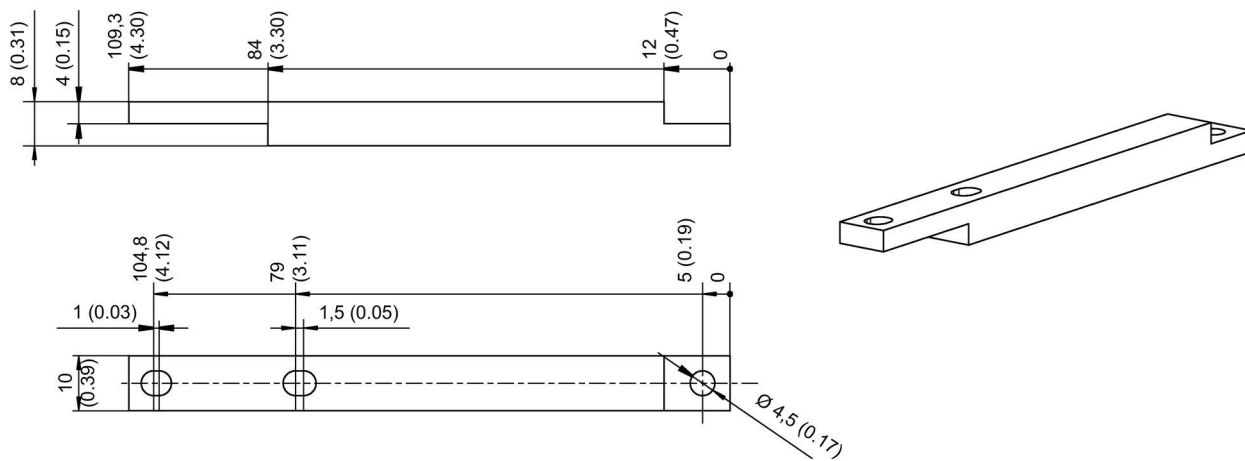

Figure 11-23 Dimension drawing of reinforced DC link busbar 100 mm, all dimensions in mm and (inches)

11.3.4 Removing the DC link busbars

Required tools:

- Torx screwdriver T20 for DC link screws (Torx slot)

Table 11- 12 Removing the DC link busbars

<p>1. Remove the installed DC link bridges and busbars, starting at the second component. Do not remove the DC link bridge and the busbars of the first component.</p>	<p>2. Loosen the screws and remove the installed DC link bridge of the component.</p>
<p>3. Remove the DC link busbar of the component.</p>	

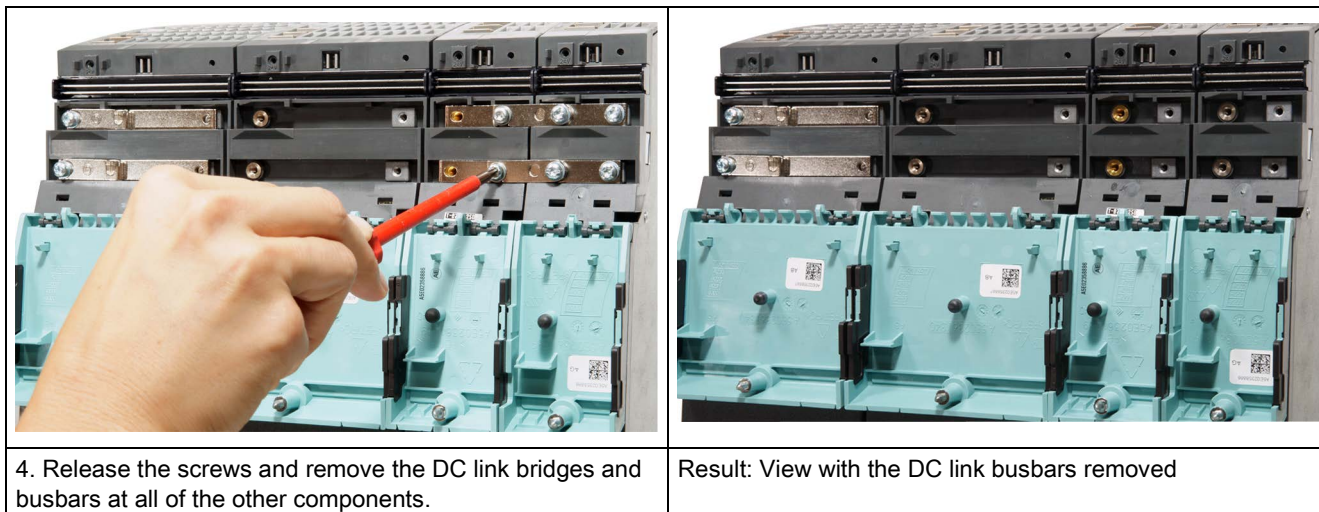

11.3.5 Installing the reinforced DC link busbars

Required tools:

- Torx screwdriver T20 for DC link screws (Torx slot)

Table 11- 13 Installing the reinforced DC link busbars

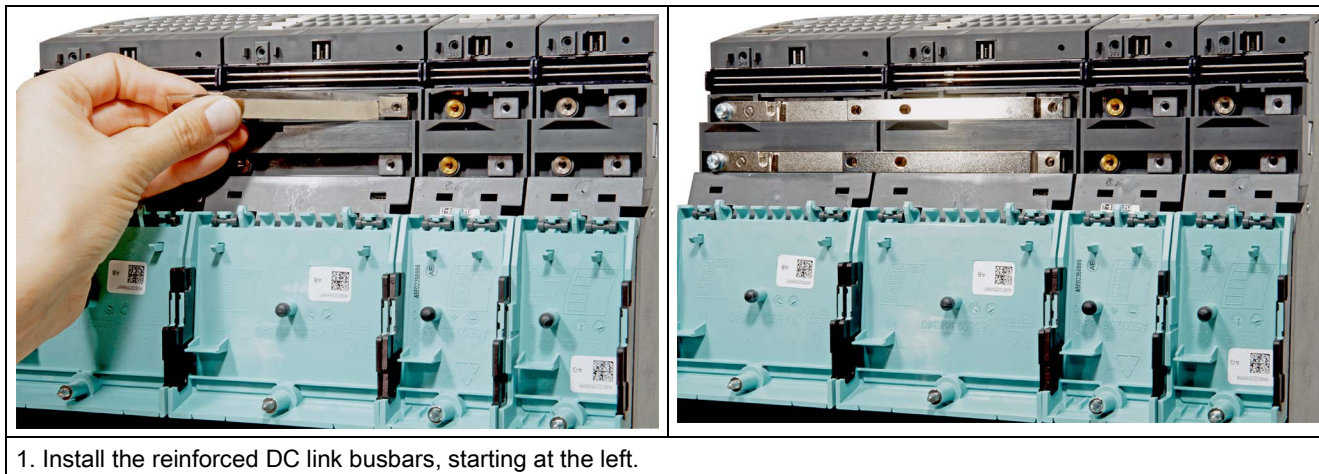

11.3 Reinforced DC link busbars

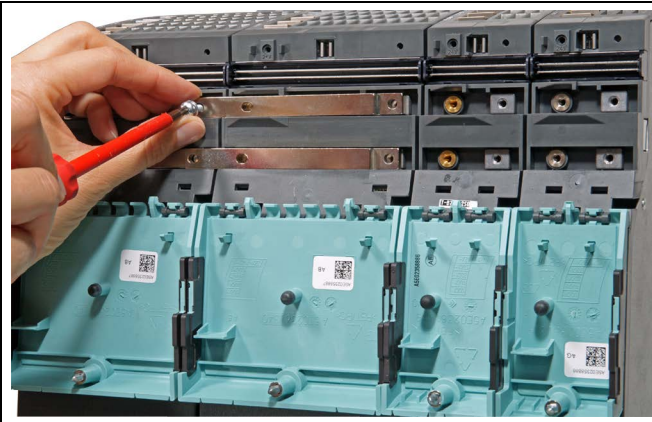

2. Attach the DC link busbars using the original M4x20 screws at the right-hand side of the component. Do not tighten the screws with their final tightening torque yet.

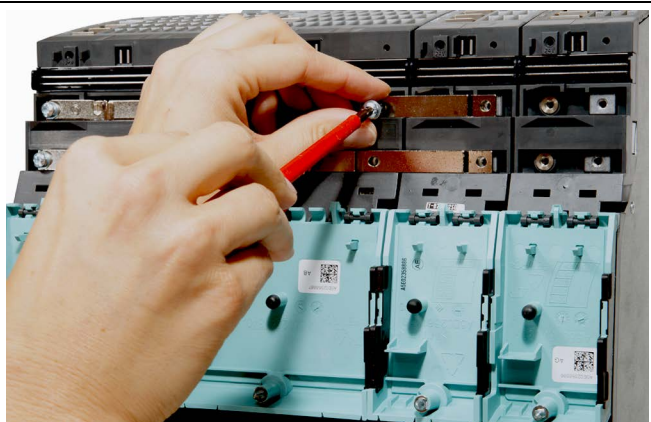

3. Install the reinforced DC link busbars, and attach these at the right-hand side of all of the remaining components.

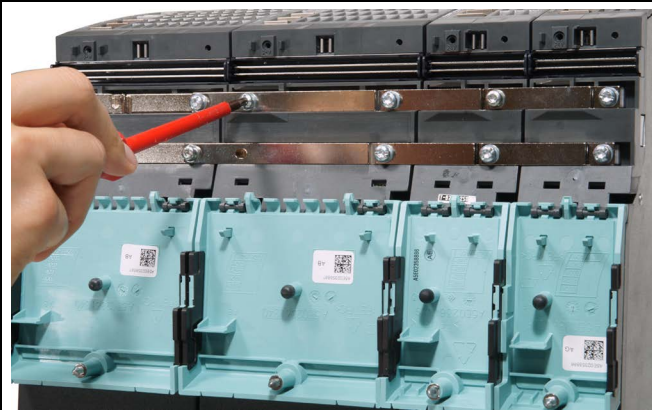

4. For 100 mm wide components, additionally attach the DC link busbars using the original M4x16 screws at the left-hand side of the component. Finally tighten the screws with 1.8 Nm (15.9 lbf in) + 30%.



Result: View of the mounted reinforced DC link busbars with 24 V connectors and 24 V terminal adapter

Note

To connect the 24 V busbars of the individual components, use the 24 V connectors provided in the accessories pack.

11.4 DC link rectifier adapter for Booksize format

11.4.1 Description

The DC link rectifier adapter supplies the DC-link voltage directly. It is best used for supplying an individual component. With a direct supply, each component is connected to the DC link separately. The internal DC link busbar is not used here.

If the DC link rectifier adapter is to be used for supplying several components, it is important to remember that it can only be installed on the component on the far right. The choice of connection cable diameter should be based on the required summation current for all the connected components.

The connection cables must be fused accordingly.

Mounting on components with reinforced DC link busbars is **not** possible.

Note

When a DC link rectifier adapter and DC busbars are used, the limit values for radio interference suppression under Category C2 according to EN 61800-3 can no longer be observed.

Table 11- 14 Available DC link rectifier adapters

Article No.	Screw terminals	Used for Line/Motor Modules with these sizes
6SL3162-2BD00-0AA0	0.5 ... 10 mm ²	50 mm, 100 mm
6SL3162-2BM00-0AA0	35 ... 120 mm ²	150 mm, 200 mm, 300 mm



DC link rectifier adapter
6SL3162-2BD00-0AA0



DC link rectifier adapter
6SL3162-2BM00-0AA0

11.4.2 Safety instructions for DC link rectifier adapters



! WARNING

Electric shock due to the residual charge of the DC-link capacitors

Because of the DC link capacitors, a hazardous voltage is present for up to 5 minutes after the power supply has been switched off.

Contact with live parts can result in death or serious injury.

- Do not open the protective cover of the DC link until 5 minutes have elapsed.
- Measure the voltage before starting work on the DCP and DCN DC link terminals.



! WARNING

Electric shock when the protective cover of the DC link is open

Contact with live parts can result in death or serious injury.

- Only operate the components with closed protective cover.



! WARNING

Electric shock due to incorrectly installed DC link bridges

Incorrectly installed DC link bridges **at the left-hand end of the drive line-up** can cause an electric shock.

- For all 50 mm wide modules¹⁾ (exception: Smart Line Module²⁾), remove the DC link bridge, including the screws. Do not tighten the screws without the DC link bridges.
- For all components that are 75 mm wide or wider, the DC link bridges may neither be swung over to the left nor removed³⁾.

¹⁾ For 50 mm wide modules, the DC link bridge cannot be swung inwards.

²⁾ Smart Line Modules do not have a DC link bridge.

³⁾ The DC link bridge guarantees the mechanical stability of the DC link busbars.

 **WARNING****Fire and device damage as a result of ground fault/short-circuit**

The DC link connection cables must be laid so that a ground fault or short-circuit is impossible. A ground fault can cause a fire with smoke development.

- Use the local installation regulations to avoid this fault.
- Protect the cables against mechanical damage.

Also implement one of the following measures:

- Use cables with double insulation.
- Maintain adequate clearance, e.g. by using spacers.
- Lay the cables in separate cable ducts or conduits.

 **WARNING****Fire due to overheating when permissible cable lengths are exceeded**

Excessively long cable lengths can cause components to overheat with the associated risk of fire and smoke.

- The total length of the DC link (including the connection cables) must not exceed 10 m.

 **WARNING****Electric shock due to incorrectly laid 24 V supply cables**

If supply cables are laid without safe electrical separation, the insulation can fail with an electric shock.

- Maintain a clearance of at least 100 mm between the 24 V supply cables and the DC link connecting cables.
- Or use cables with double insulation (e.g. sheathed cables) for the 24 V supply cables.

 **WARNING****Fire as a result of incorrectly dimensioned overcurrent protection in the DC link connecting cable**

Incorrectly dimensioned overcurrent protective devices can result in a fire and associated smoke.

- Protect personnel and prevent fires by dimensioning the overcurrent protective devices in the DC link connecting cable corresponding to the particular application.
- Comply with local installation regulations.
- Carefully check the overcurrent protection device to ensure that it functions perfectly, and maintain it regularly in accordance with local installation regulations.

11.4.3 Interface description

11.4.3.1 Overview

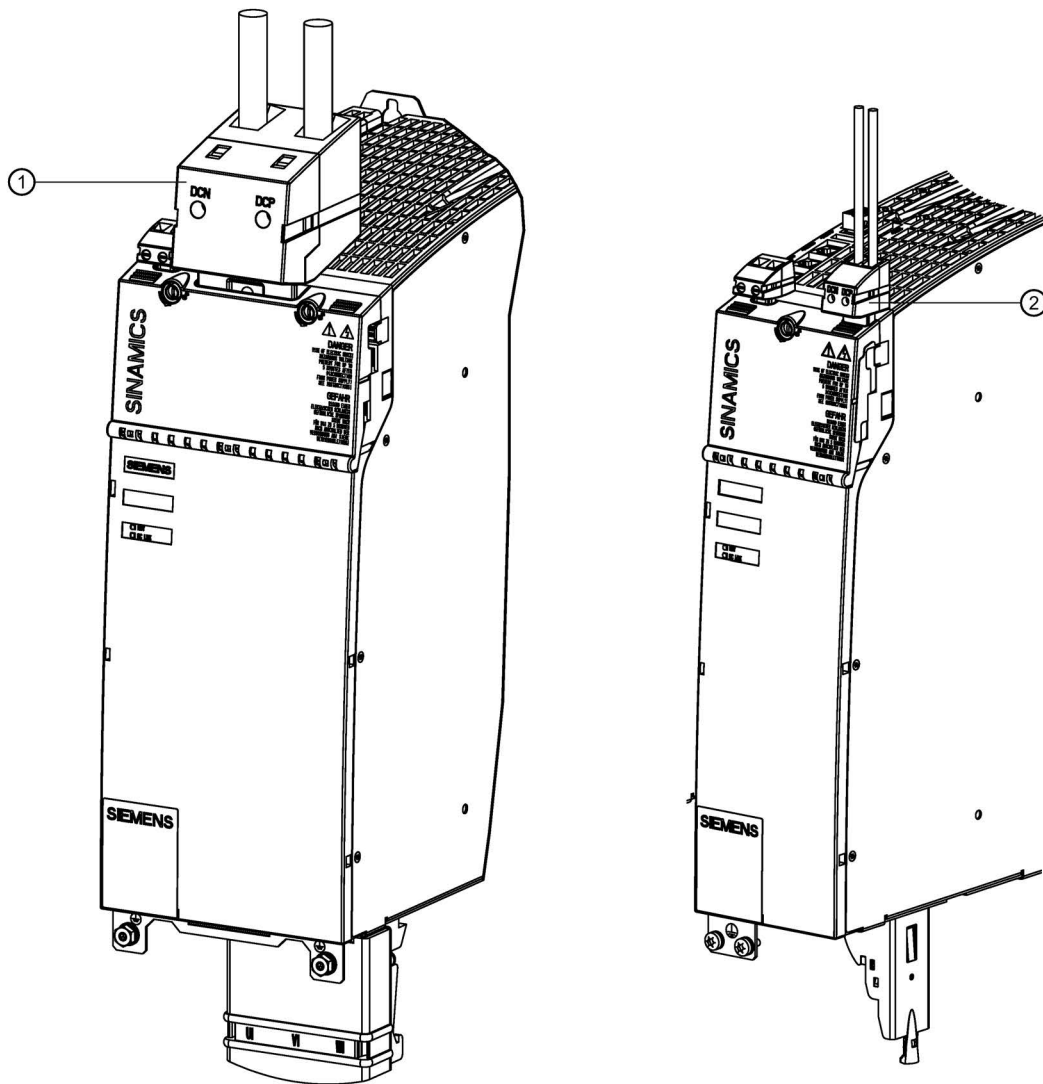

- ① DC link rectifier adapter (35 to 95 mm²) on a 150 mm component
- ② DC link rectifier adapter (0.5 to 10 mm²) on a 100 mm component

Figure 11-24 Installed DC link rectifier adapter, using the example of components with a width of 100 mm and 150 mm

11.4.3.2 DC link connection

Table 11- 15 DC link rectifier adapter – description of the terminals

Terminal	Function	Technical data
DCP	DC link positive	Supply voltage: 720 V-VDE/600 V-UL
DCN	DC link negative	

11.4.4 Dimension drawings

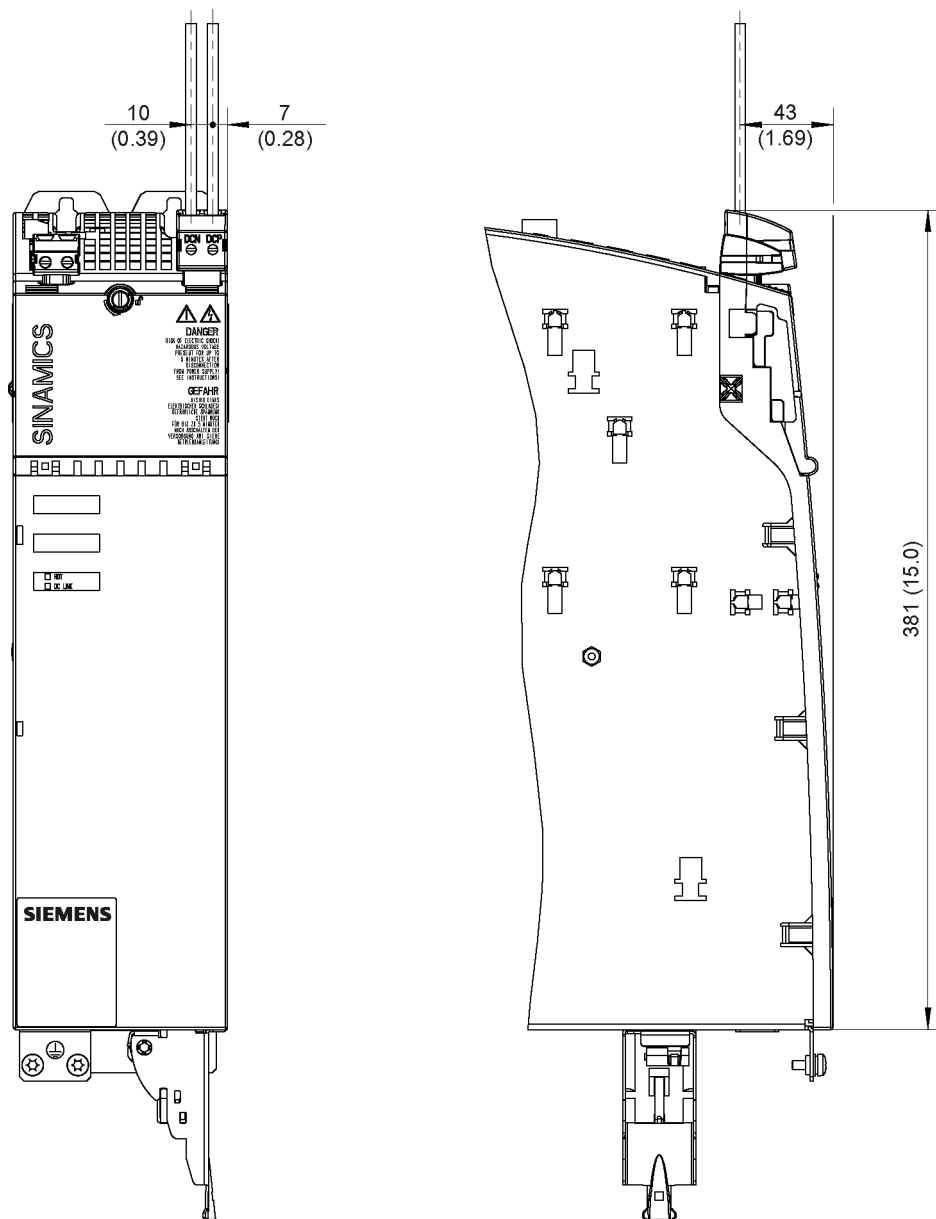

Figure 11-25 Dimension drawing of 100 mm wide component with DC link rectifier adapter for 0.5 to 10 mm², all dimensions in mm and (inch)

11.4 DC link rectifier adapter for Booksize format

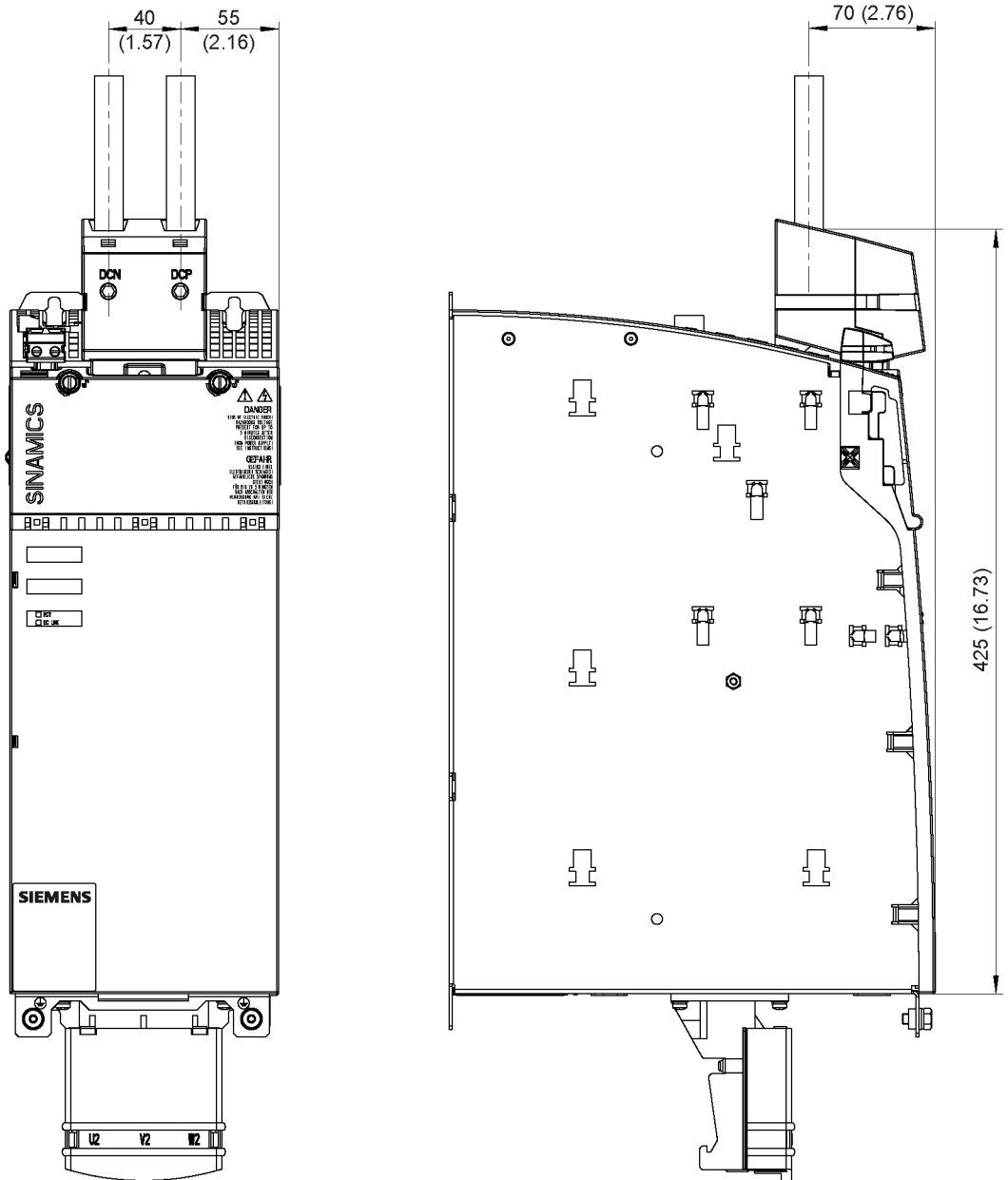

Figure 11-26 Dimension drawing of 150 mm wide component with DC link rectifier adapter for 35 to 95 mm², all dimensions in mm and (inch)

11.4.5 Mounting



⚠ WARNING

Electric shock if the cutout in the protective cover has been broken out

Live components are open and accessible if the 24 V terminal adapter or the DC link infeed adapter are removed. Touching live components can result in death or severe injury.

- Replace the protective cover with the broken out cutouts by a new protective cover.

11.4.5.1 Installation on components that are 50 mm and 100 mm wide

Required tools:

- Slot-head screwdriver (1 x 5.5) for releasing the protective cover
- Torx T10 screwdriver to fasten the 24 V terminal adapter
- Torx screwdriver T20 for DC link screws (Torx slot)
- Pliers for breaking out the cutouts

Table 11- 16 Removing the DC link busbars

<p>1 x 5,5</p>	<p>T20</p>	
<p>1. Release and open the protective cover.</p>	<p>2. Remove the upper left-hand screw and the DC link bridge</p>	<p>3. Remove the lower left-hand screw and the DC link bridge</p>

11.4 DC link rectifier adapter for Booksize format

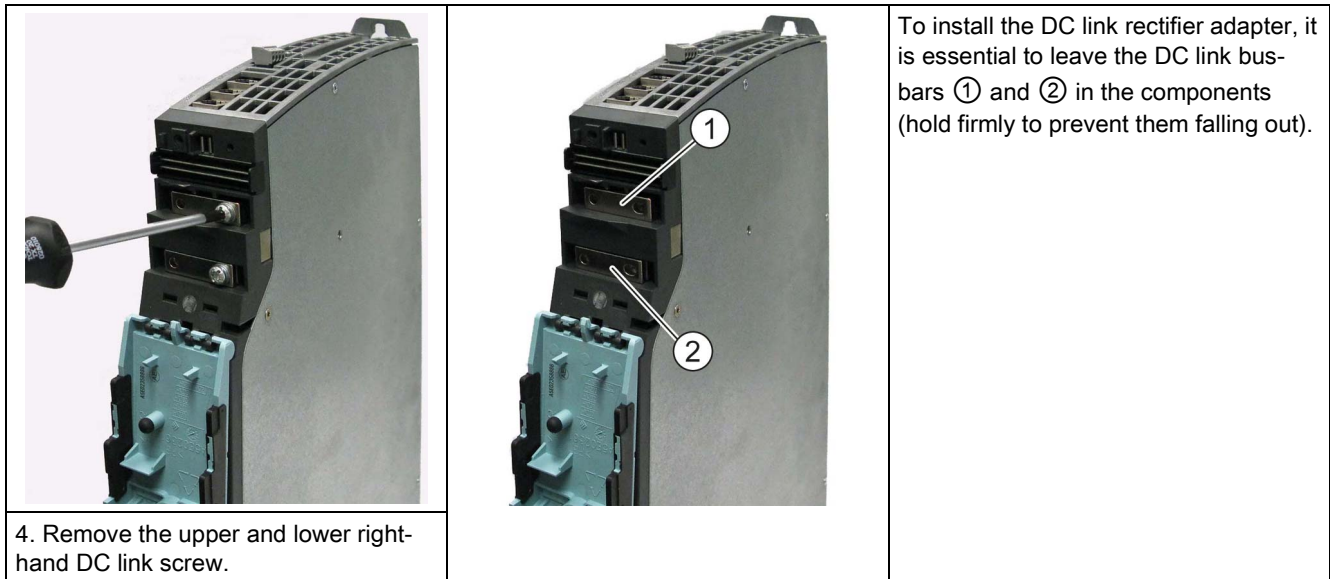
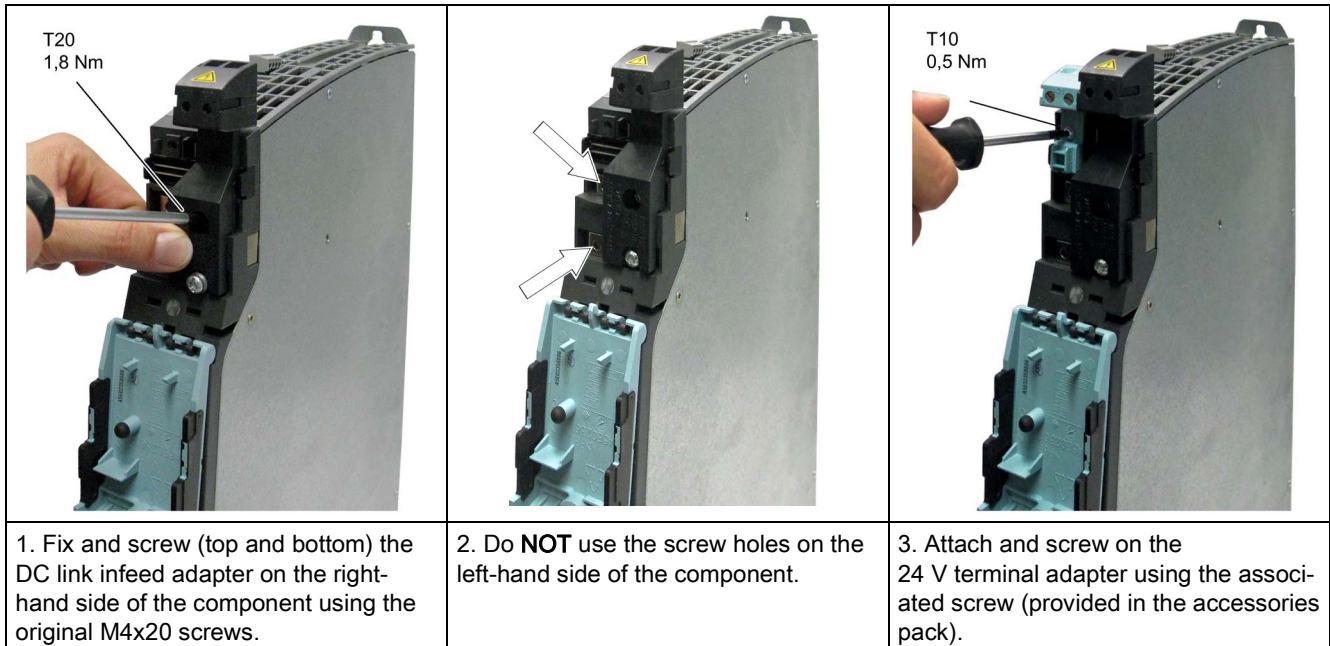

Table 11- 17 Installing the DC link rectifier adapter and 24 V terminal adapter



11.4 DC link rectifier adapter for Booksize format

<p>4. Breakout the cutouts in the protective cover.</p>	<p>5. Close the protective cover until you hear it snap into place.</p>	<p>6. Component with installed DC link rectifier adapter and 24 V terminal adapter</p>

11.4.5.2 Installation on components that are 150 mm, 200 mm and 300 mm wide



Required tools:

- Slot-head screwdriver (1 x 5.5) for releasing the protective cover
- Torx T10 screwdriver to attach the adapter
- Torx screwdriver T20 for DC link screws (Torx slot)
- Pliers for knocking out the cutouts

Table 11- 18 Installation of the DC link rectifier adapter for 150 mm, 200 mm and 300 mm components

<p>1. Release and open the protective cover.</p>	<p>2. Remove the DC link screws.</p>	<p>3. Engage the adapter in the grille.</p>

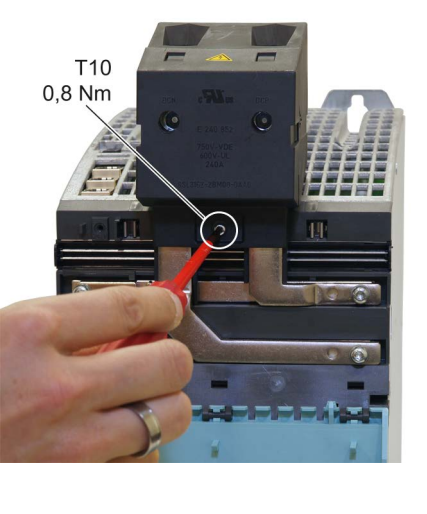
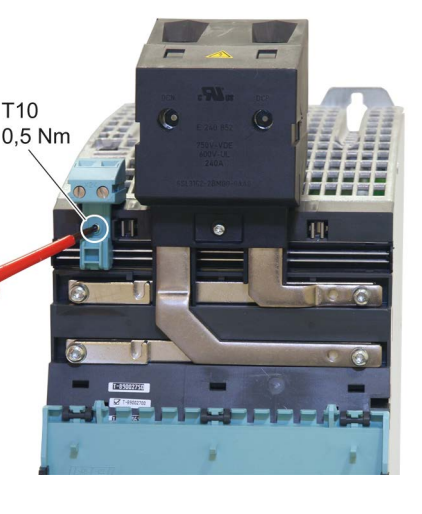
11.4 DC link rectifier adapter for Booksize format

		
<p>4. Fix the adapter bars with the DC link screws previously removed.</p>	<p>5. Fix the adapter with the associated screw (accessories pack).</p>	<p>6. Insert and screw on the 24 V terminal adapter using the associated screw (provided in the accessories pack).</p>
		
<p>7. Breakout the cutouts in the protective cover.</p>	<p>8. Close the protective cover until you hear it snap into place.</p>	

11.4.6 Electrical connection

Required tools:

- Flat-bladed screwdriver (0.8 x 4.0) for 50 mm and 100 mm components
- Size 6 Allen key for 150 mm, 200 mm and 300 mm components

Table 11- 19 Electrically connecting the DC link rectifier adapter for 50 mm and 100 mm components

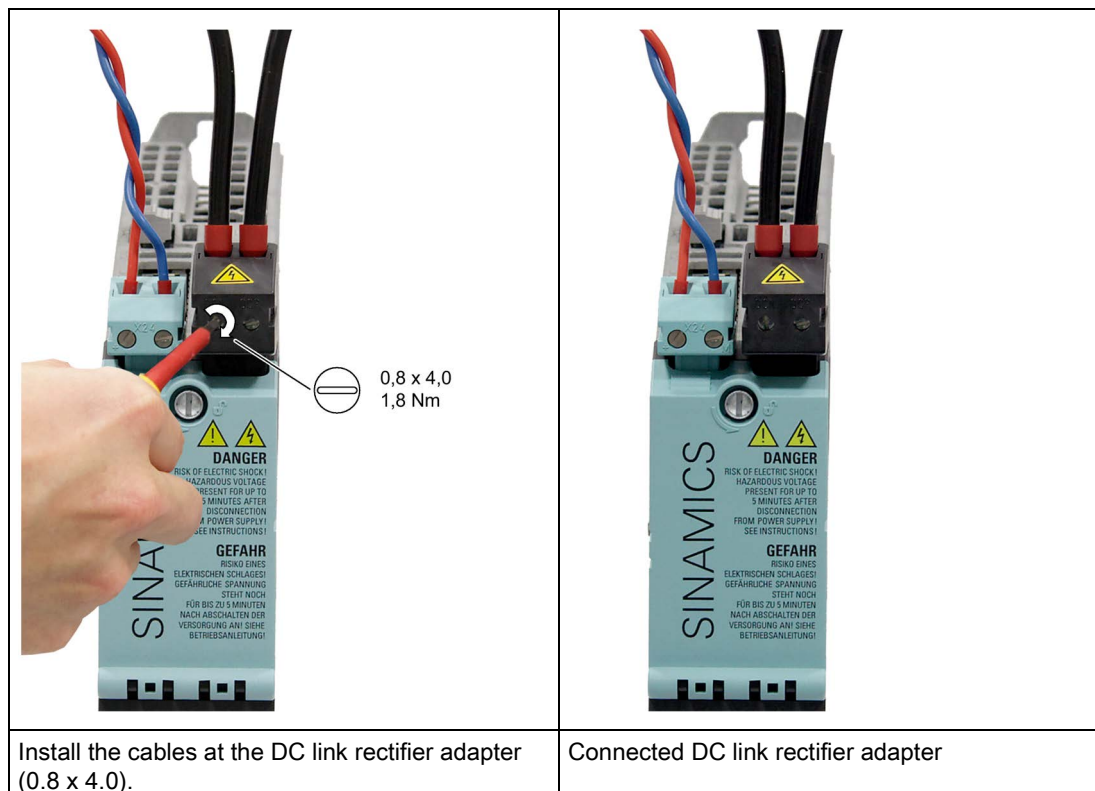

11.4 DC link rectifier adapter for Booksize format

Table 11- 20 Electrically connecting the DC link rectifier adapter for 150 mm, 200 mm and 300 mm components

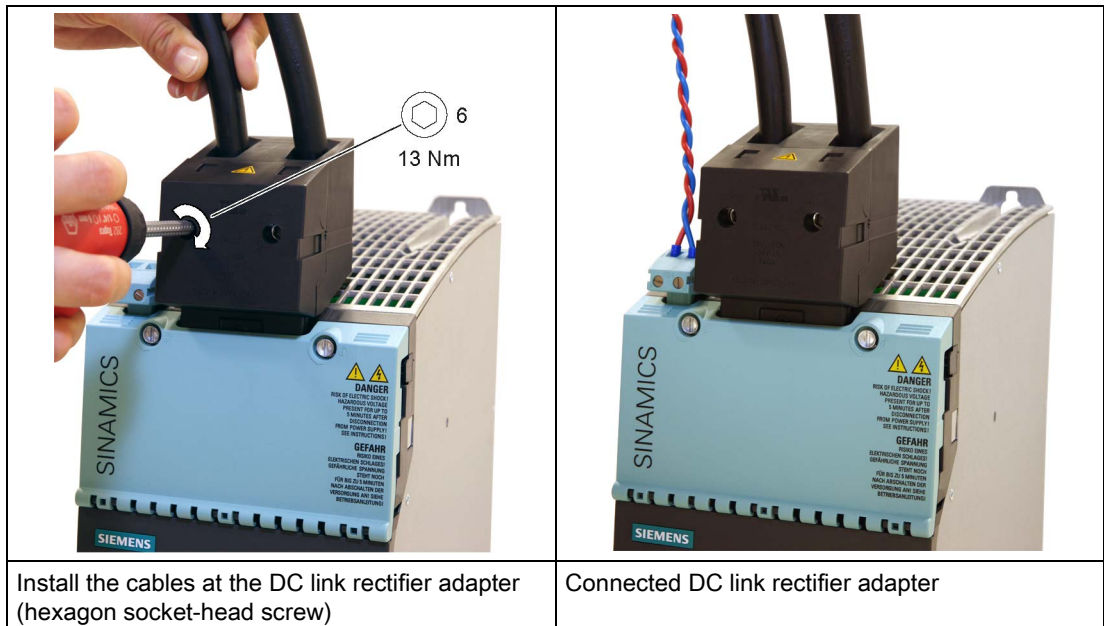

11.4.7 Technical specifications

Table 11- 21 Technical data DC link rectifier adapter

DC link rectifier adapter	Unit	6SL3162-2BD00-0AA0	6SL3162-2BM00-0AA0
Current carrying capacity	A	43	240 ¹⁾
Connection cross-section		0.5 ... 10 mm ² (AWG 20 ... 8)	35 ... 95 mm ² (AWG 2 ... 3/0)
Stripped length	mm	11	27
Attaching - Terminals - DC link busbars		Slotted screw (0.8 x 4.0) Torx screw T20	Hexagonal screw, size 6 Torx screw T20
Tightening torque - Terminals - DC link busbars		1.8 Nm (15.9 lbf in) 1.8 Nm (15.9 lbf in)	13 Nm (115 lbf in) 1.8 Nm (15.9 lbf in)

1) If only one of the two screws is used to connect the infeed adapter with DCP and DCN, then the current carrying capacity is reduced to 150 A.

11.5 DC link adapter

11.5.1 Description

DC-link adapters are required if the drive line-up is to be subdivided between two or more rows.

The 6SL3162-2BM01-0AA0 DC-link adapter can be mounted on all Line Modules and Motor Modules in the Booksize format without reinforced DC-link busbars.

The 6SL3162-2BM10-0AA0 DC-link adapter can be mounted on 50 mm and 100 mm wide Line Modules and Motor Modules in the Booksize format with reinforced DC-link busbars.

To connect the various sub line-ups, use shielded individual conductors that are mechanically secured.



DC-link adapter
6SL3162-2BM01-0AA0

(4-hole adapter)



DC-link adapter
6SL3162-2BM10-0AA0

for installation using reinforced DC-link bus-
bars
(2-hole adapter)

11.5.2 Safety instructions for DC link adapters



 WARNING
Electric shock due to the residual charge of the DC-link capacitors
Because of the DC link capacitors, a hazardous voltage is present for up to 5 minutes after the power supply has been switched off.
Contact with live parts can result in death or serious injury.
<ul style="list-style-type: none"> • Do not open the protective cover of the DC link until 5 minutes have elapsed. • Measure the voltage before starting work on the DCP and DCN DC link terminals.



 WARNING
Electric shock when the protective cover of the DC link is open
Contact with live parts can result in death or serious injury.
<ul style="list-style-type: none"> • Only operate the components with closed protective cover.



 WARNING
Electric shock due to incorrectly installed DC link bridges
Incorrectly installed DC link bridges at the left-hand end of the drive line-up can cause an electric shock.
<ul style="list-style-type: none"> • For all 50 mm wide modules¹⁾ (exception: Smart Line Module²⁾), remove the DC link bridge, including the screws. Do not tighten the screws without the DC link bridges. • For all components that are 75 mm wide or wider, the DC link bridges may neither be swung over to the left nor removed³⁾.
¹⁾ For 50 mm wide modules, the DC link bridge cannot be swung inwards.
²⁾ Smart Line Modules do not have a DC link bridge.
³⁾ The DC link bridge guarantees the mechanical stability of the DC link busbars.



 WARNING
Electric shock due to missing DC-link side covers
Live parts are exposed if the DC link side covers are not fitted. Contact with these live parts could cause an electric shock.
<ul style="list-style-type: none"> • Mount the side covers on the first and last component in the drive line-up. • Order any missing side covers (Article number: 6SL3162-5AA00-0AA0).

**! WARNING****Electric shock due to improper DC link connection**

Incorrect connections can cause overheating and so fire and smoke development. There is also a risk of an electric shock. This can result in serious injury or death.

- When connecting to the DC link, only use the adapter that has been approved by Siemens (DC link adapter).

! WARNING**Fire and damage to equipment due to short-circuit / ground fault**

The DC link connection cables must be laid so that a ground fault or short-circuit is impossible. A ground fault can cause a fire with smoke development.

- Protect the cables against mechanical damage.
- Use the local installation regulations to avoid this fault.

Also implement one of the following measures:

- Use cables with double insulation.
- Maintain adequate clearance, e.g. by using spacers.
- Lay the cables in separate cable ducts or conduits.

! WARNING**Fire due to overheating when permissible cable lengths are exceeded**

Excessively long cable lengths can cause components to overheat with the associated risk of fire and smoke.

- Ensure that the total length of the DC link including the connecting cables does not exceed 10 m.

11.5.3 Interface description

11.5.3.1 Overview

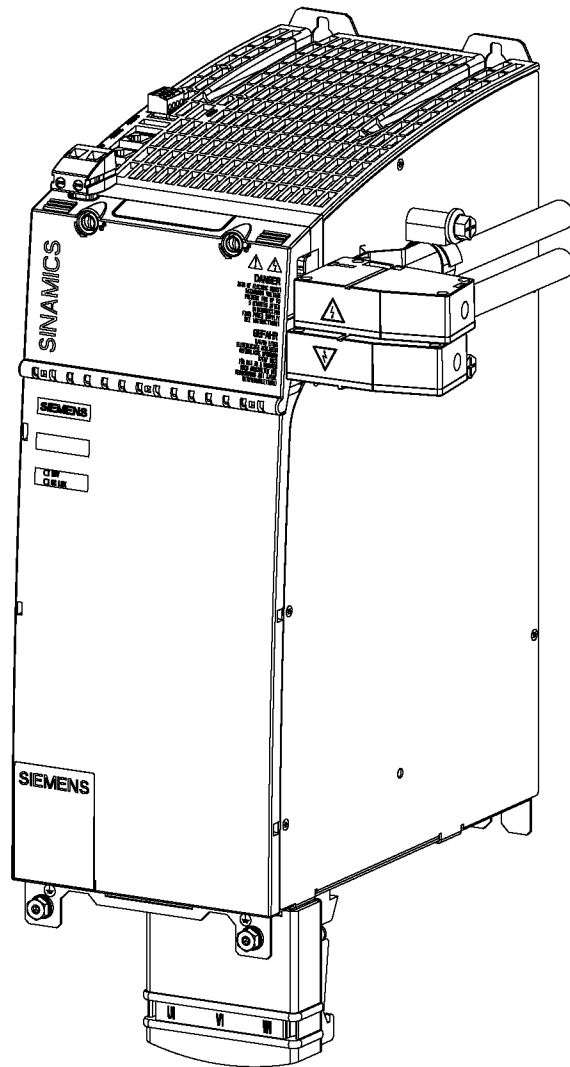

Figure 11-27 150 mm wide components with DC link adapter for multi-tier configurations

11.5.3.2 DC link connection

Table 11- 22 DC link connection

Terminal	Function
DCP	DC link positive
DCN	DC link negative

**⚠ WARNING**

Electric shock or fire if the necessary clearances and creepage distances are not complied with

When using non-insulated end sleeves, the required clearances and creepage distances are not complied with! This can result in flashover between the cables and the undesirable formation of arcs. As a consequence, there is a risk of electric shock and fire.

- Only use DC link connecting cables with insulated end sleeves.

11.5.4 Dimension drawing

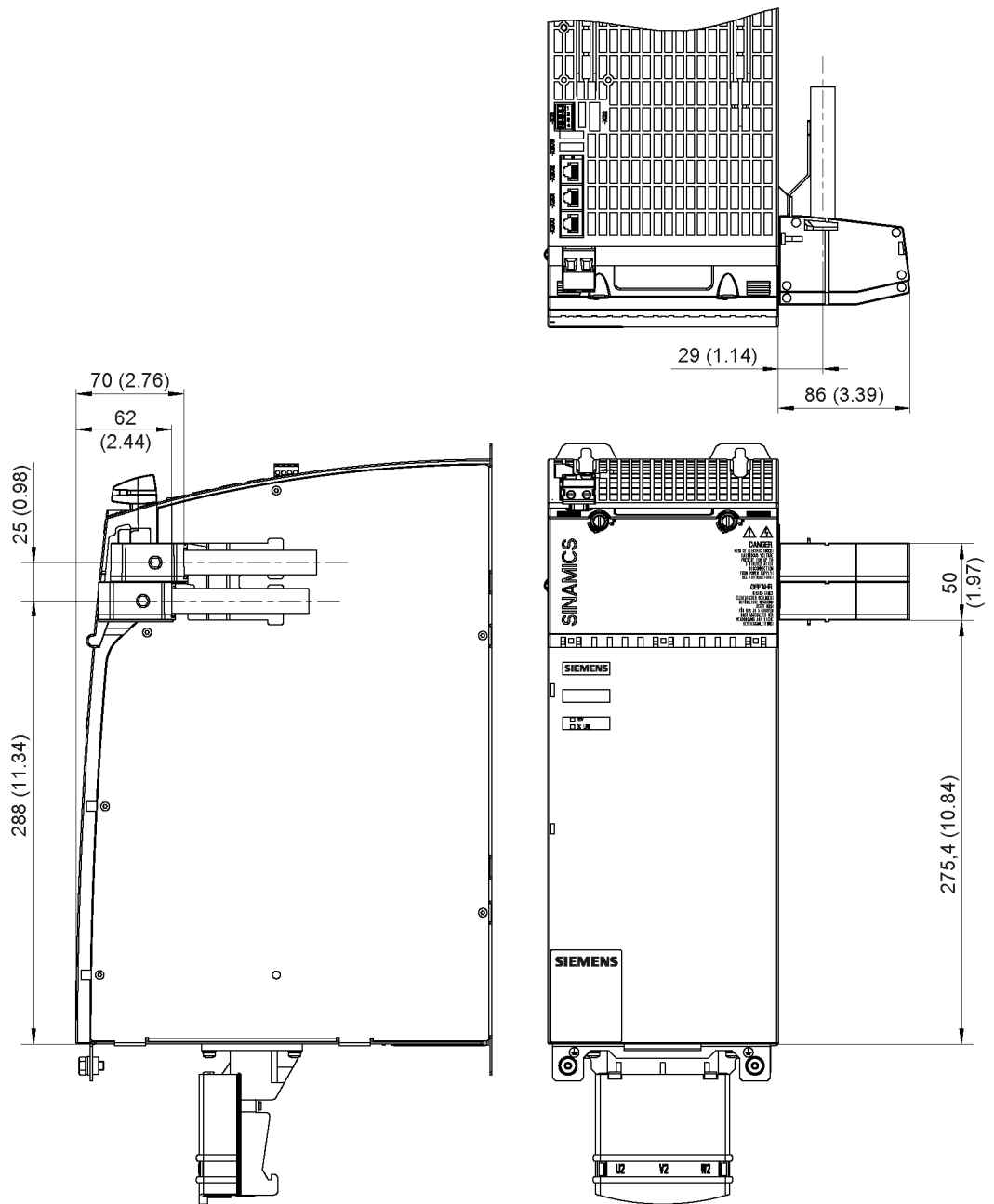

Figure 11-28 Dimension drawing of a 150 mm wide component with DC link adapter, all dimensions in mm and (inches)

11.5.5 Installation

Note

By moving the adapter housing, the DC link adapter can be fitted on either the left-hand or right-hand side of the component. This configuration is possible for all Active Line Modules.

Required tools:

- Slot-head screwdriver (1 x 5.5) for releasing the protective cover
- Torx screwdriver T20 for DC link screws (Torx slot)

Table 11- 23 Mounting the DC link adapter

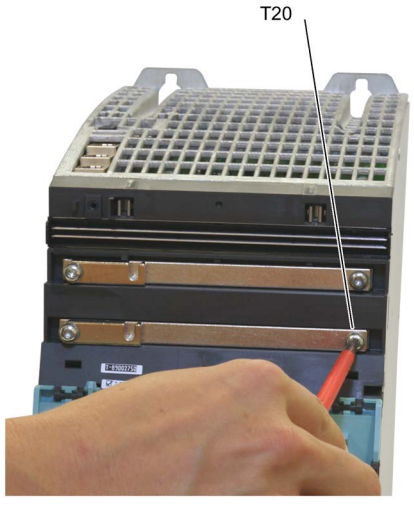
	
<p>1. Release and open the protective cover of the DC link.</p>	<p>2. Remove the DC link screws.</p>

11.5 DC link adapter

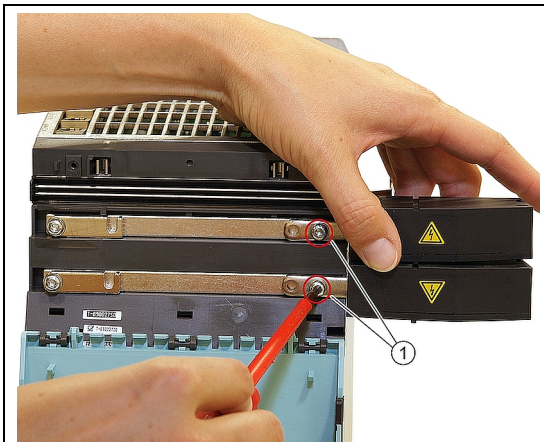

3. Fix the DC link adapter (1.8 Nm / 15.9 lbf in) with the previously removed DC link screws¹⁾. When installing using two screws, use the **right-hand** holes ①.

¹⁾ Observe the special issues when using reinforced DC link busbar (refer below)

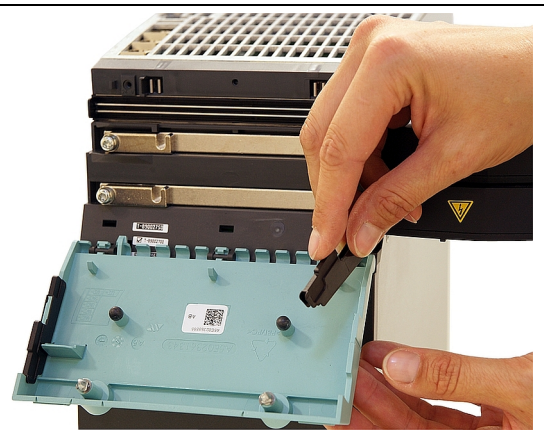

4. Remove the DC link side cover, install the 24 V terminal adapter (if required) and close the protective cover until it audibly clicks into place.



Result:
Installed DC link adapter and 24 V terminal adapter



⚠ WARNING

Electric shock when touching the DC link busbars

Contact with live parts can result in death or serious injury.

- The DC link adapters must be installed so that after closing the DC link cover they cannot be touched!

! WARNING
Electric shock due to incorrectly installed DC link bridges

Incorrectly installed DC link bridges at the left-hand end of the drive line-up can cause an electric shock.

- For all 50 mm wide modules (exception: Smart Line Modules), remove the DC link bridge, including the screws. Do not tighten the screws without the DC link bridges.
- For all components that are 75 mm wide or wider, the DC link bridges must neither be moved to the left nor swung out from the module.

NOTICE
Damage when mounting using 2 screws

For DC link adapters that are mounted using only 2 screws, currents above 150 A result in a high temperature rise. This can damage the DC link adapter or the component.

- If the DC link adapter is only mounted using 2 screws, then you must limit the current to 150 A.

Note

- When mounting with only 2 screws, use the inner hole of the adapter busbar.

Using washers when mounting the DC link adapter

! WARNING
Overheating and fire when mounting the DC link adapter without washers

When mounting the DC link adapter with combination screws M4x20 without using the washers provided, can result in the DC link busbar overheating and causing a fire. This can result in death or severe injury.

- Use one of the washers provided for each screw.

DC link adapters are supplied with washers, which are attached using a securing strap at the inner hole of the DC link busbar. These washers must be used if a DC link adapter is mounted on the left-hand side of a 150 to 300 mm wide module (one for each screw). It is not permissible that they are used for other mounting scenarios.

Module width	DC link adapter connection	
	Left	Right
50 - 100 mm	No washers	No washers
150 - 300 mm	Washers	No washers

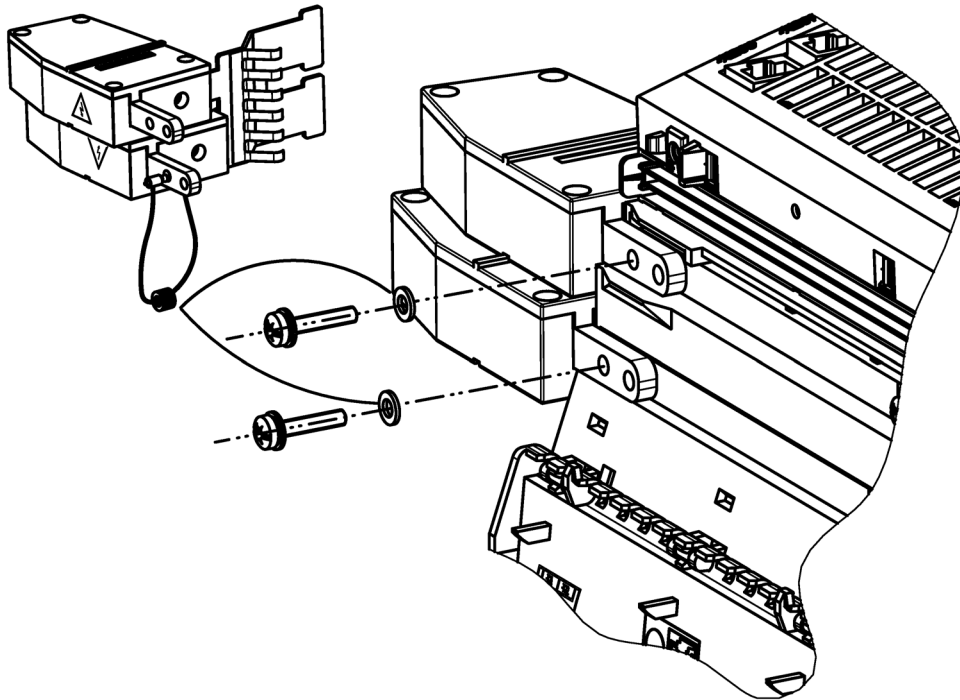
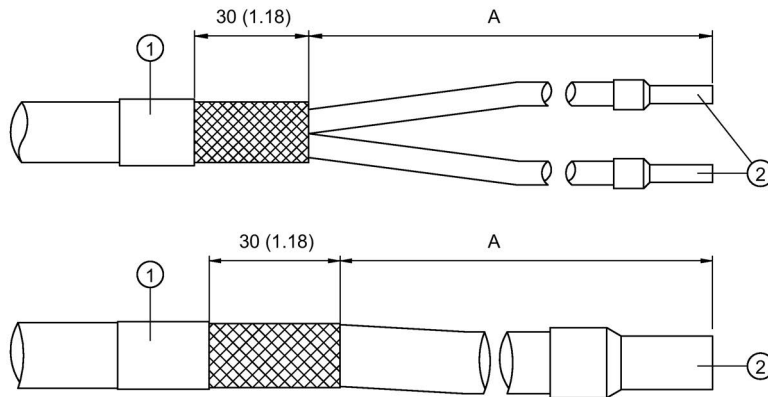

Figure 11-29 Mounting a DC link adapter on the left-hand side for module widths of 150 to 300 mm using 2 screws

11.5.6 Electrical connection

11.5.6.1 Preparing the cables

1. Prepare the DC link connecting cables as shown below.
2. Only use shielded cables with insulated end sleeves.



- ① Protective braided shield folded back and fixed using shrink-on sleeve
- ② Insulated end sleeve

Figure 11-30 Single-core and two-core DC link connecting cable with insulated end sleeves, all dimensions in mm and (inch)

Refer to the table below for dimension A:

Conductor cross-section [mm ²]	Mounting location of the DC link adapter at the drive line-up	Connection	A [mm]
35 / 50 / 70 / 95	Left	DCP	60
		DCN	70
	Right	DCP	60
		DCN	70

11.5.6.2 Fixing the cables to the rear cabinet panel

1. Fix the DC link connecting cables directly next to the last component at the rear control cabinet panel. Use the C-profile rails and the appropriate cable clamps from the Rittal company. The distance between the C profile rail and the lower side of the component is approximately 125 mm.
2. Appropriately insulate the cable cores at the connection location before mounting.

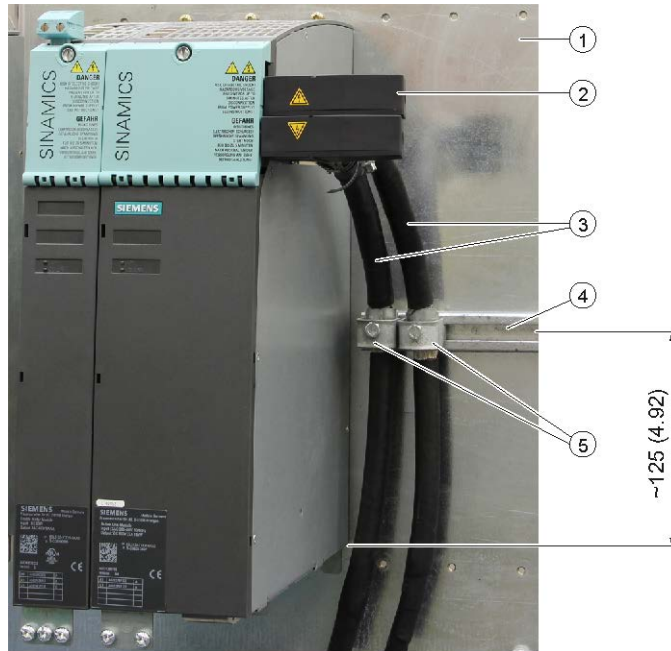

- ① Control cabinet panel
- ② DC link adapter
- ③ Cores of the DC link connecting cable
- ④ C-profile rail from Rittal company (article number 7831.570 / 7831.571)
- ⑤ Cable clamps for C profile rails from the Rittal company.

Figure 11-31 Fixing the DC link connecting cable to the control cabinet panel, dimensions in mm and (inch)



11.5.6.3 Cable connection and shield support

In order to simplify installing the DC link connecting cables at the DC link adapter, first fix the cables to the control cabinet panel (see above).

Required tools:

- Size 6 Allen key to attach the cables
- Suitable tool for hose clamps, e.g. flat-bladed screwdriver

Table 11- 24 Connecting the DC link connecting cables to the DC link adapter

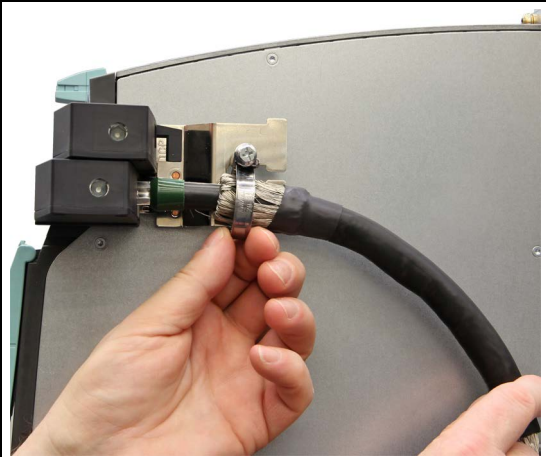
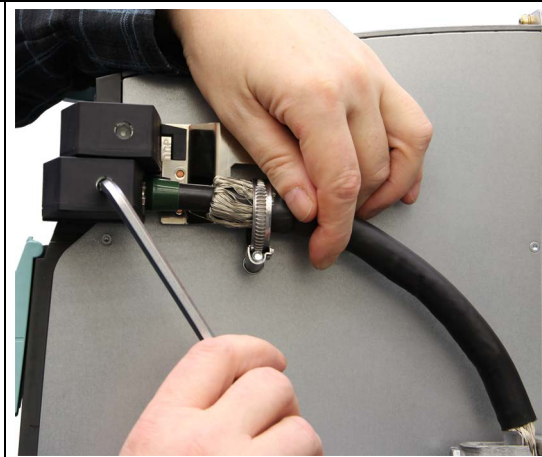
	
<p>1. Fix the first conductor of the DC link connecting cable to the profile rail using a cable clamp.</p>	<p>2. Route the cable end through an appropriate cable clamp.</p>
	
<p>3. Slide the cable clamp onto the tongue, and then insert the end of the cable into the DCN connection of the DC link adapter.</p>	<p>4. Tighten the cable using an Allen key.</p>

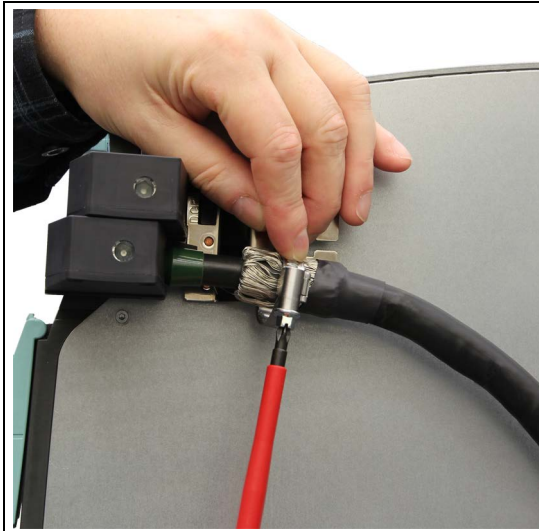

5. Tighten the screw of the hose clamp using a suitable screwdriver.

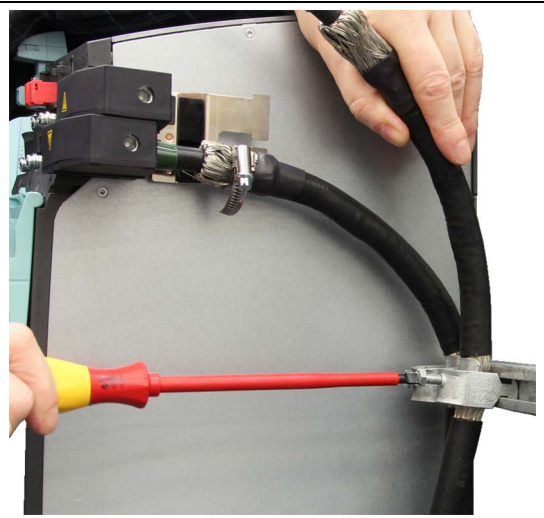

6. Fix the second conductor of the DC link connecting cable to the profile rail using a cable clamp.

Connect the cable for the DCP connection as described under Points 2 to 5.

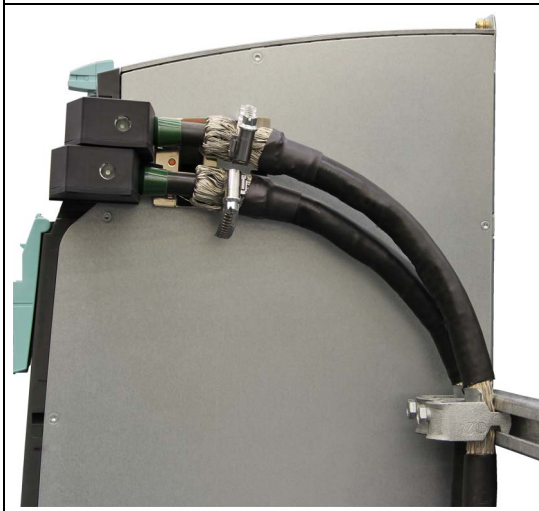

The installed DC link connecting cable is shown in the adjacent diagram.

Note

After installing the cables, ensure that the EMC tongues of the DC link adapter are in contact with the side panel of the component.

11.5.7 Technical specifications

Table 11- 25 Technical data DC link adapter

6SL3162-	Unit	2BM01-0AA0	2BM10-0AA0
Current-carrying capacity – attached using 2 screws – attached using 4 screws	A A	150 240	150 ---
Connection cross-section		35 ... 95 mm ² (AWG 2 ... 3/0)	35 ... 95 mm ² (AWG 2 ... 3/0)
Stripped length	mm	27	27
Tightening torque – terminals – DC link busbars		13 Nm (115 lbf in) 1.8 Nm (15.9 lbf in)	13 Nm (115 lbf in) 1.8 Nm (15.9 lbf in)
Weight	kg	0.34	0.33

11.6 DRIVE-CLiQ cabinet bushings

11.6.1 Description

A DRIVE-CLiQ cabinet bushing is used to connect the DRIVE-CLiQ cables between the inside and outside of the control cabinet. It is used in a control cabinet panel. The data lines and the voltage supply contacts of the DRIVE-CLiQ are also routed through the bushing. The DRIVE-CLiQ cabinet bushing for DRIVE-CLiQ cables is available with DRIVE-CLiQ connector and M12 connector/socket.

DRIVE-CLiQ cabinet bushing for DRIVE-CLiQ connectors

The cabinet bushing has degree of protection IP54 according to IEC 60529 from the outside towards the inside. Inside the control cabinet, a connection is established according to degree of protection IP20 or IPXXB acc. to IEC 60529. So that the complete outside of the cabinet bushing, including the DRIVE-CLiQ interface, has degree of protection IP54, a DRIVE-CLiQ cable must be used, which as a minimum must also have degree of protection IP54.

DRIVE-CLiQ cabinet bushing for M12 connector/socket

The cabinet bushing has degree of protection IP67 according to IEC 60529 from the outside towards the inside. Inside the cabinet a connection according to degree of protection IP67 in compliance with IEC 60529 is realized.

11.6.2 Interface description

11.6.2.1 Overview

DRIVE-CLiQ cabinet bushing for DRIVE-CLiQ cables with DRIVE-CLiQ connectors

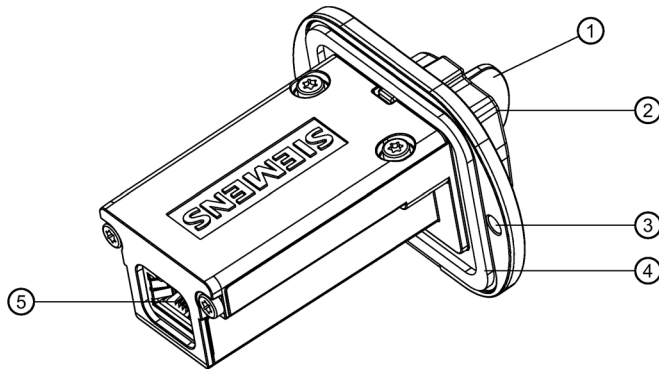

- ① Protective cap, Yamaichi, Article No.: Y-ConAS-24-S
- ② DRIVE-CLiQ interface on the outside (to connect DRIVE-CLiQ signal cables MOTION-CONNECT with IP67 degree of protection)
- ③ Mounting holes
- ④ Flange-type seal to ensure degree of protection IP54 on the outside of the cabinet
- ⑤ DRIVE-CLiQ interface on the inside (to connect DRIVE-CLiQ signal cables MOTION-CONNECT with IP20 degree of protection)

Figure 11-32 Interface overview, DRIVE-CLiQ cabinet bushing

DRIVE-CLiQ cabinet bushing for DRIVE-CLiQ cables with M12 plug/socket

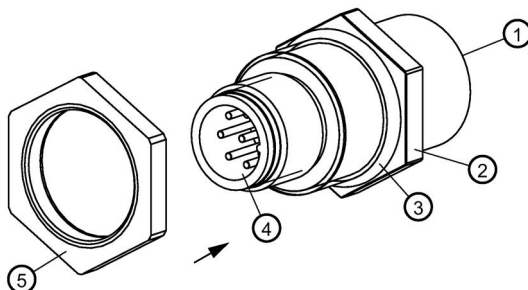

- ① DRIVE-CLiQ interface with M12 socket (8-pin)
- ② Flange, SW18
- ③ Seal
- ④ DRIVE-CLiQ interface with M12 plug (8-pin)
- ⑤ O ring, SW20, tightening torque: 3 ... 4 Nm (26.6 ... 35.4 lbf in)

Figure 11-33 Interface overview, DRIVE-CLiQ cabinet bushing M12

11.6.3 Dimension drawings

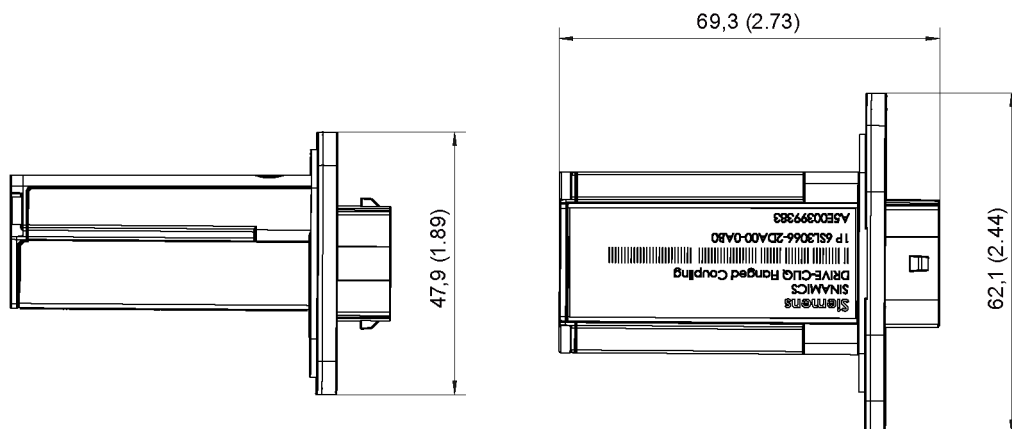
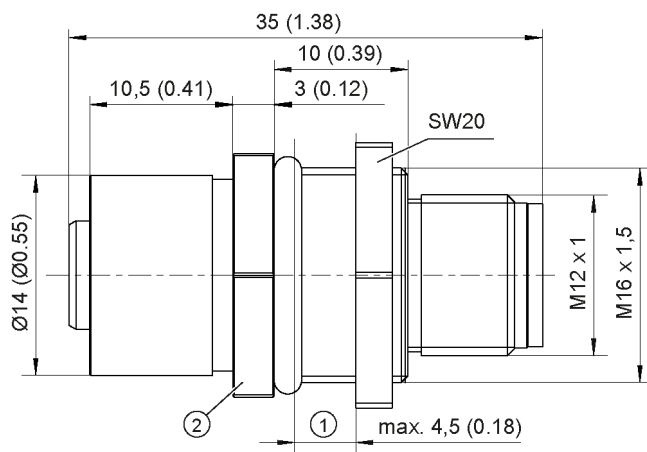

Figure 11-34 Dimension drawing of the DRIVE-CLiQ cabinet gland, all dimensions in mm and (inches)



- ① Cabinet panel
- ② Flange, SW18

Figure 11-35 Dimension drawing of the DRIVE-CLiQ cabinet bushing M12, all dimensions in mm and (inches)

11.6.4 Mounting

11.6.4.1 DRIVE-CLiQ cabinet bushing for cables with RJ45 connectors

In order to install the DRIVE-CLiQ cabinet gland, you must make a cutout in the control cabinet panel as shown in the diagram below.

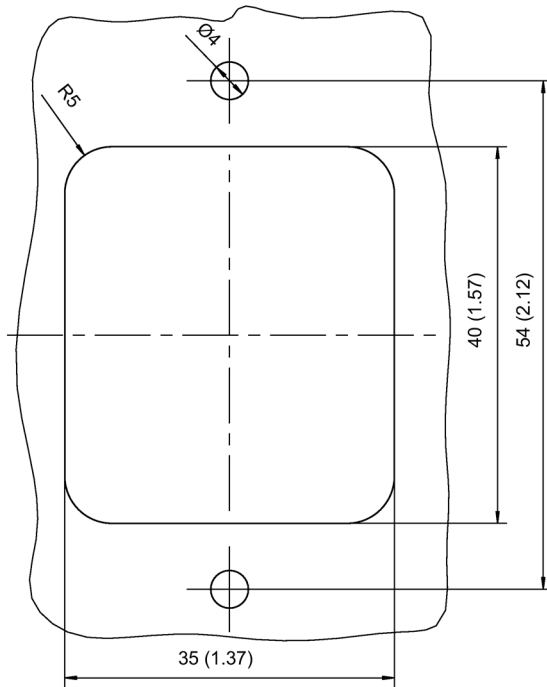
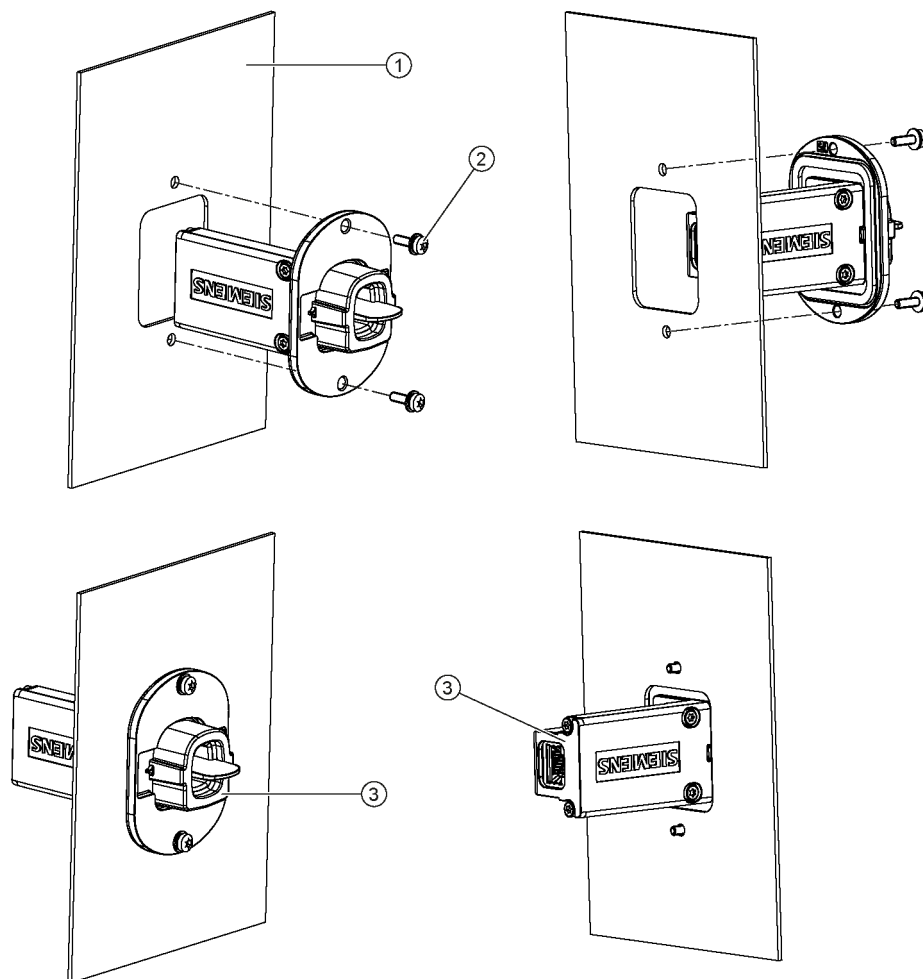

Figure 11-36 Cutout in the control cabinet, all dimensions in mm and (inches)

1. Insert the DRIVE-CLiQ cabinet bushing from the outside of the control cabinet through the cutout in the control cabinet.
2. Attach the DRIVE-CLiQ cabinet bushing to the outer control cabinet panel using 2 M3 screws and 2 nuts. In order to ensure good electromagnetic compatibility, a good electrical connection must be established between the DRIVE-CLiQ cabinet gland and the cabinet panel over a large surface area.



- ① Control cabinet panel
- ② Screw M3, tightening torque 0.8 Nm (7.1 lbf in)
- ③ DRIVE-CLiQ cabinet bushing

Figure 11-37 Installing the DRIVE-CLiQ cabinet bushing for cables with DRIVE-CLiQ connectors

11.6.4.2 DRIVE-CLiQ cabinet bushing for cables with M12 plug/socket

Prepare the cabinet panel for mounting the DRIVE-CLiQ cabinet bushing M12 as shown below. The removable O ring can be screwed from the inside or the outside.

Mounting from the inside using an O ring that can be screwed

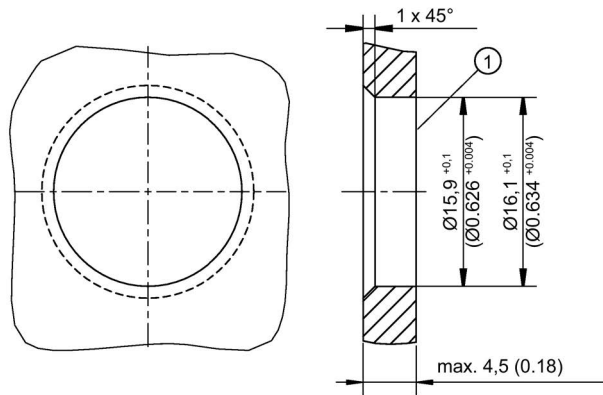

① Through-hole with chamfer

Figure 11-38 Through-hole for mounting the DRIVE-CLiQ cabinet bushing M12 with an O-ring that can be screwed from the inside

Mounting from the outside using an O ring that can be screwed

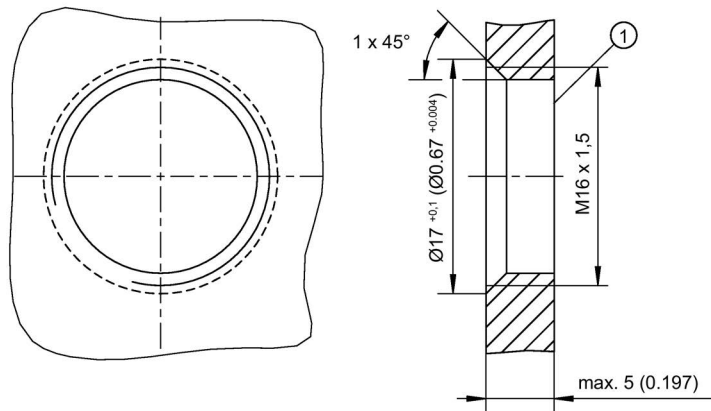

① Threaded hole with chamfer

Figure 11-39 Threaded hole for mounting the DRIVE-CLiQ cabinet bushing M12 with an O-ring that can be screwed from the outside

Mounting

1. Insert the DRIVE-CLiQ cabinet bushing through the opening in the cabinet.
2. Fasten the DRIVE-CLiQ cabinet bushing using the associated O ring with a tightening torque of 3 - 4 Nm (26.6 ... 35.4 lbf in).

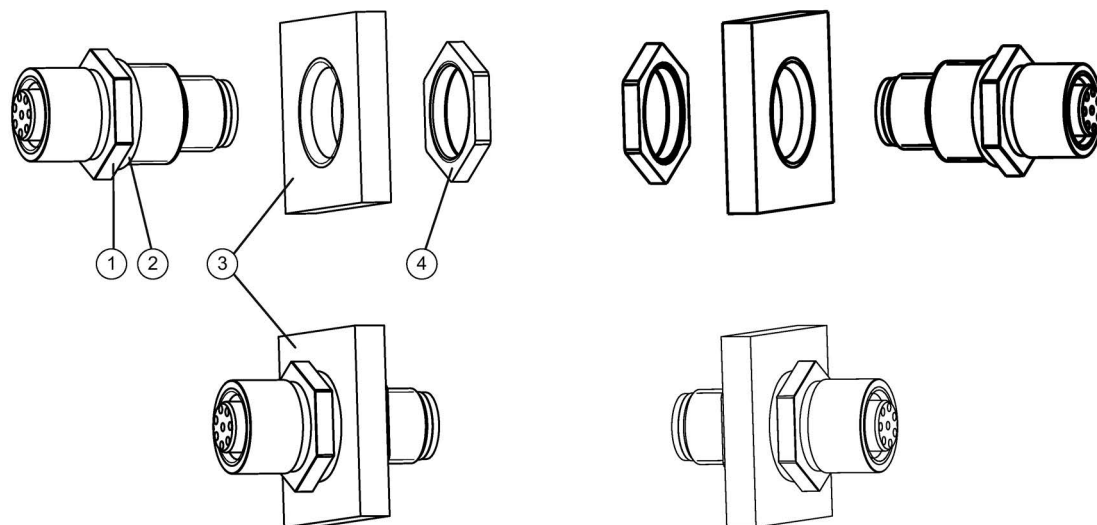

- ① Flange, SW18
- ② Seal
- ③ Cabinet panel
- ④ O ring, SW20, tightening torque: 3 ... 4 Nm (26.6 ... 35.4 lbf in)

Figure 11-40 Mounting DRIVE-CLiQ cabinet bushings for cables with M12 connectors

11.6.5 Technical data

Table 11- 26 Technical data of DRIVE-CLiQ cabinet bushings

	Unit	6SL3066-2DA00-0AA0 DRIVE-CLiQ	6FX2003-0DT67 M12
Weight	kg	0.165	0.035
Degree of protection to IEC 60529		IP54 outside the control cabinet IP20 or IPXXB inside the control cabinet	IP67

11.7 DRIVE-CLiQ coupling

11.7.1 Description

The DRIVE-CLiQ coupling is used to connect 2 DRIVE-CLiQ cables in accordance with degree of protection IP67 acc. to IEC 60529.

In addition to the data lines, the power supply contacts of DRIVE-CLiQ are also routed via the coupling.

You can find information on the permissible cable length in Chapter DRIVE-CLiQ signal cables (Page 683)

11.7.2 Interface description

11.7.2.1 Overview

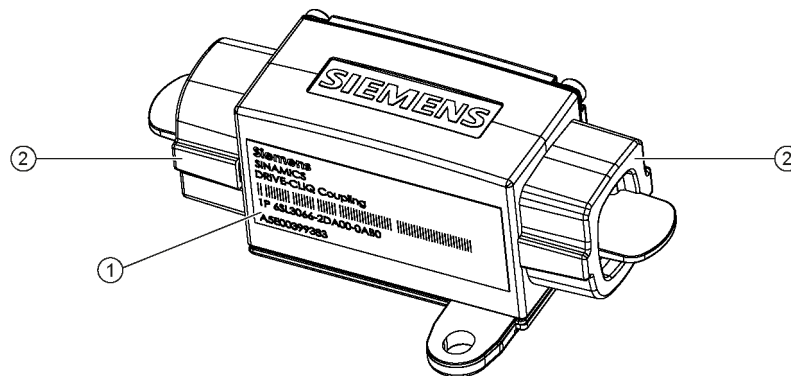

- ① Rating plate
- ② Protective cap, Yamaichi, Article No.: Y-ConAS-24-S

Figure 11-41 Interface overview, DRIVE-CLiQ coupling

11.7.3 Dimension drawing

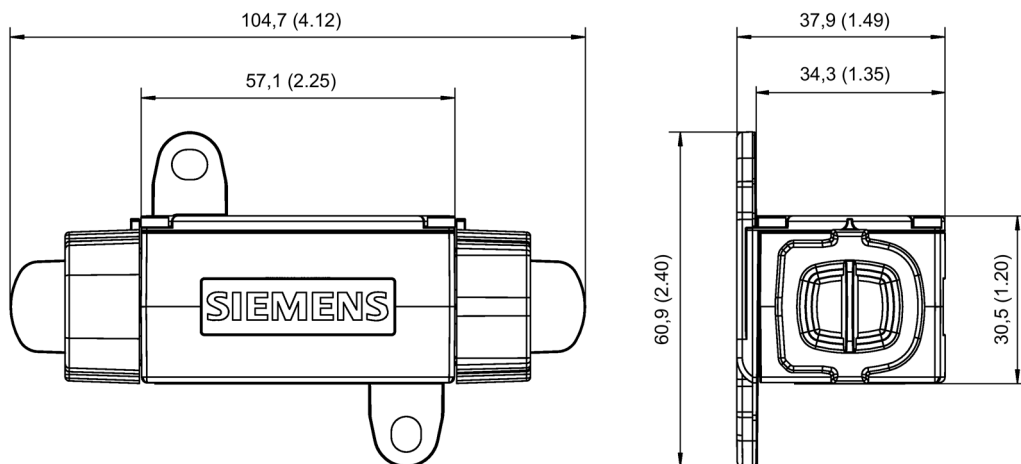
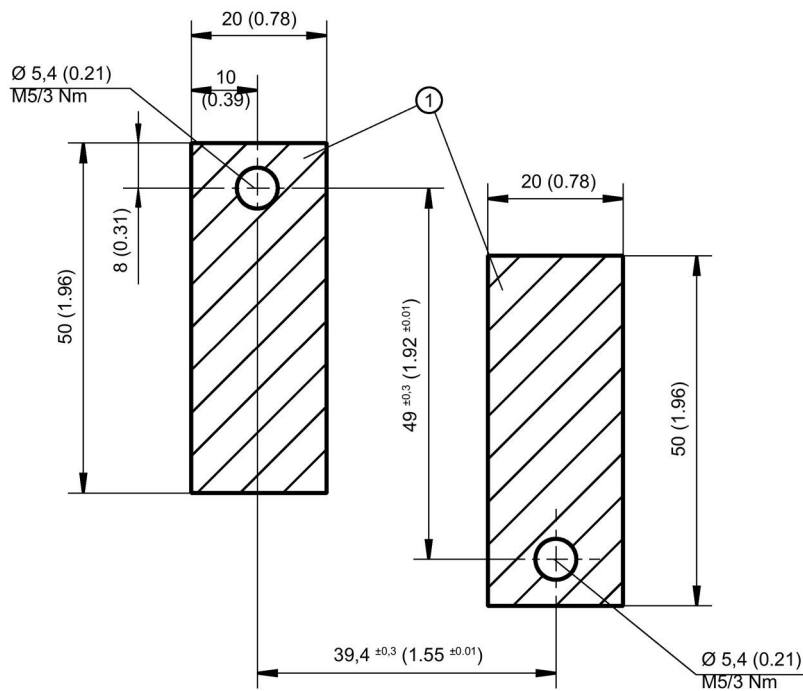

Figure 11-42 Dimension drawing of the DRIVE-CLiQ coupling, all dimensions in mm and (inches)

11.7.4 Mounting



① Contact surface

Figure 11-43 Hole drilling pattern for installation

Installation

1. Attach the DRIVE-CLiQ coupling to the mounting surface as shown in the drilling pattern.
2. Remove the protective caps of the DRIVE-CLiQ coupling.
3. Latch the DRIVE-CLiQ connectors at both sides of the DRIVE-CLiQ coupling.

11.7.5 Technical data

Table 11- 27 Technical data

DRIVE-CLiQ coupling 6SL3066-2DA00-0AB0	Unit	
Weight	kg	0.272
Degree of protection	IP67 according to IEC 60529	

11.8 Spacing bolt for Booksize Compact components

To increase the mounting depth of modules in Booksize Compact format, use spacer bolts (article number: 6SL3462-1CC00-0AA0). In this way, it is possible to combine modules in Booksize Compact format directly with booksize modules with internal air cooling.

Table 11- 28 Number of spacing bolts and holes for various module widths

Module width in [mm]	Number of spacing bolts	Number of holes/press-in nuts
50	2	2
75	4	4
100	4	4

Mounting the spacing bolts with press-in nuts

- Inserting M6 press-in nuts into the mounting panel
- Distance 25 mm \pm 0.15 mm for module width 75 mm
- Distance 50 mm \pm 0.15 mm for module width 100 mm

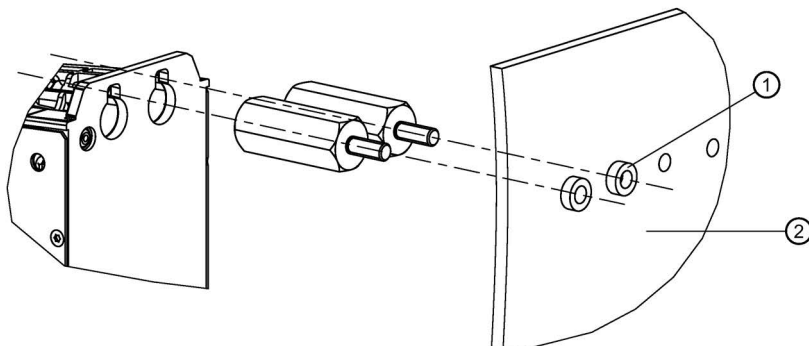

- ① M6 press-in nuts
- ② Mounting panel

Figure 11-44 Mounting the M6 press-in nuts on the rear of the mounting panel

As an alternative to press-in nuts, you can secure spacing bolts with M6 nuts to the rear of the mounting panel.

Mounting spacing bolts with nuts

- Drill \varnothing 6.5 mm holes for spacing bolts
- Distance 25 mm \pm 0.15 mm for module width 75 mm
- Distance 50 mm \pm 0.15 mm for module width 100 mm

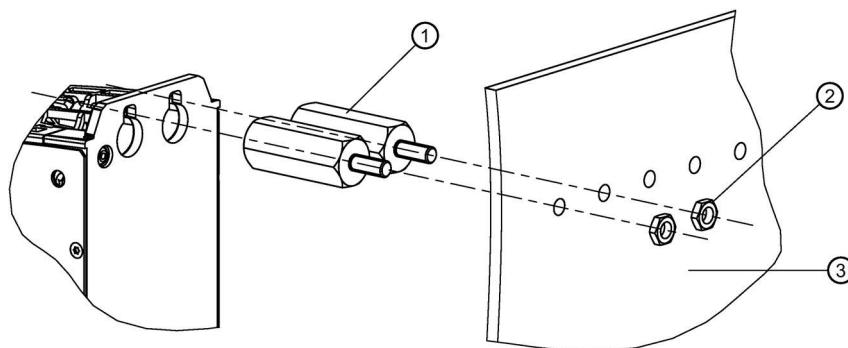

- ① Spacing bolt
- ② M6 nuts
- ③ Mounting panel

Figure 11-45 Mounting the spacing bolts with M6 nuts on the rear of the mounting panel

Tightening torque: 6 Nm (53.1 lbf in)

Mounting a component in booksize compact format with spacing bolts

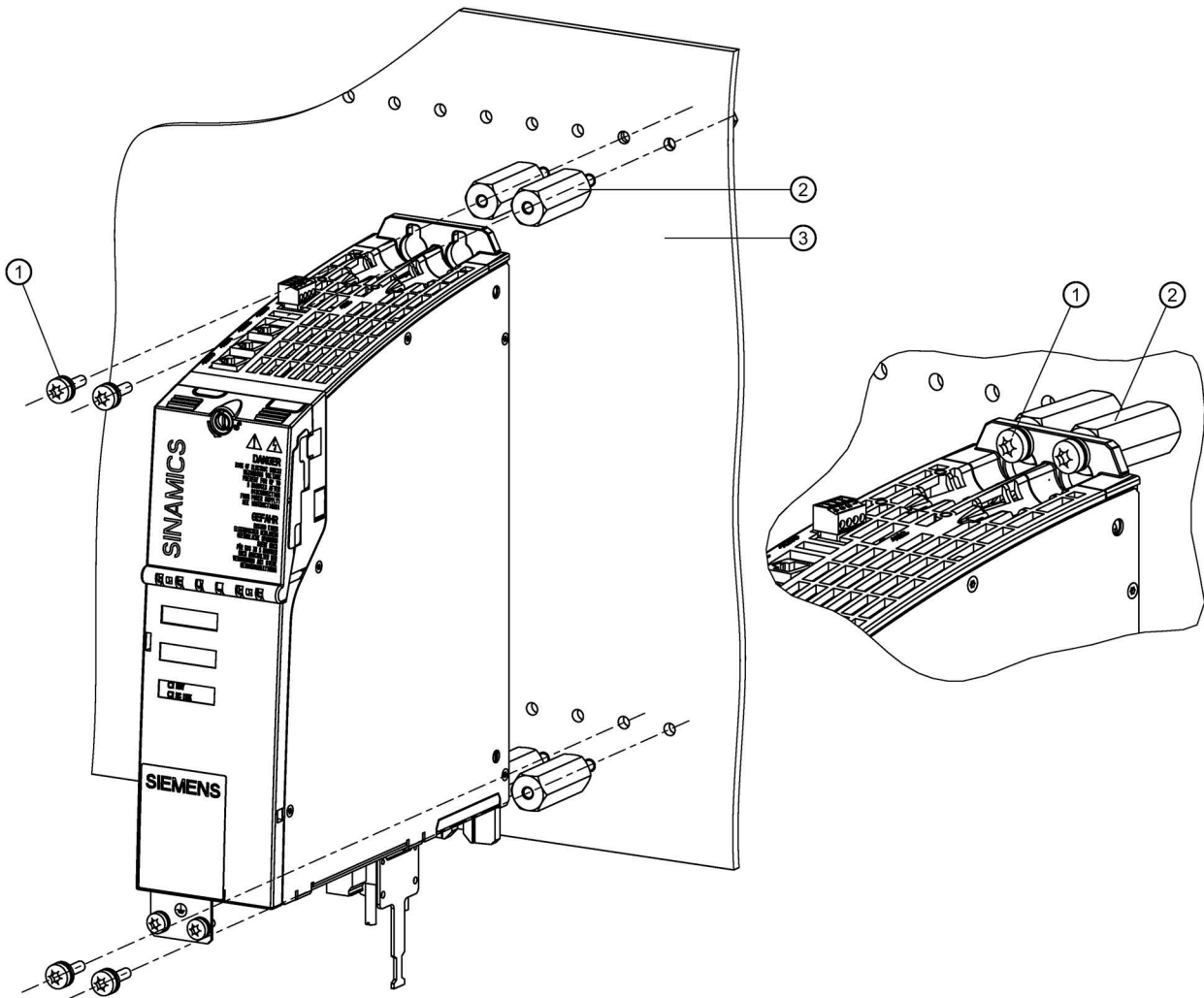

- ① Screw M6 x 20
- ② Spacing bolts, SW 17 (6SL3462-1CC00-0AA0)
- ③ Mounting panel

Figure 11-46 Mounting a component in booksize compact format with spacing bolts (example: Motor Module Booksize Compact, 18 A)

Tightening torque: 6 Nm (53.1 lbf in)

12.1 General information

SINAMICS S components are available as chassis units with degree of protection IP20 or IPXXB according to IEC 60529 and as open type devices to UL 50. This therefore ensures that fingers cannot come into contact with any active components.

To ensure also protection against mechanical stress and climatic conditions, the components must always be operated in housings, cabinets or enclosed electrical operating areas/rooms that fulfill at least degree of protection IP54 according to European enclosure specifications, or in compliance with US, Canadian and Mexican regulations as enclosure type 12, according to NEMA 250.

Note

Protection against the spread of fire

The converter may be operated only in closed housings or in higher-level control cabinets with protective covers that are closed, and when all of the protective devices are used.

Converters of the open type / IPXXB degree of protection must be installed in a metal control cabinet or protected by another equivalent measure such that fire cannot spread and emissions outside of the control cabinet are prevented.

Note

Protection against condensation and electrically conductive contamination

To ensure the functional safety and safety functions of Safety Integrated, protect the converter, e.g. by installing it in a control cabinet with degree of protection IP54 according to IEC 60529 or Type 12 according to NEMA 250. Further measures may be necessary for particularly critical operating conditions.

If condensation and conductive pollution can be excluded at the installation site, a lower degree of cabinet protection is permissible.

Low-voltage switchgear and controlgear assemblies

If the SINAMICS S drive line-up is used for the electrical equipment of machines, the applicable requirements of EN 60204-1 must also be adhered to.

Safety of machinery - electrical equipment of machines

All information relating to device selection in this section applies to

- Operation on TN and TT line supply systems with grounded neutral point and grounded protective conductor as well as to IT line supply systems
- Operating voltage range from 3-phase 380 ... 480 V AC ± 10 %

12.2 Safety instructions when mounting and installing the control cabinet

 **WARNING**

Risk of injury as a result of foreign bodies in the device

Parts (e.g.: drilling chips, end sleeves) falling into the device can cause short-circuits and damage the insulation. This can result in severe injury (arcing, loud bang, parts that are flung out).

- Only perform installation and other work when the devices are current-free.
- Cover the ventilation slots when mounting and installing the control cabinet and remove the cover before switching on.

12.3 Electromagnetic compatibility

12.3.1 General information

Electromagnetic compatibility (EMC) means that the devices function satisfactorily, without interfering with other devices and without being disrupted by other devices. The EMC requirements for "Variable-speed drive systems" (Power Drive System PDS) is described in product standard IEC/EN 61800-3.

A variable-speed drive system consists of a Control Unit, Line Module and Motor Module - as well as the associated electric motors, encoders and connecting cables. The driven machine is not part of the drive system.

Note

PDS as component of machines or systems

For the integration of PDS into machines or systems, additional measures may be required so that the product standards of these machines or systems is complied with. The machine or system builder is responsible for taking these measures.

12.3.2 Environments and categories

The EMC environments and categories are defined in the EMC Product Standard EN 61800-3, as follows:

Environments

IEC/EN 61800-3 makes a distinction between the first and second environments - and defines different requirements for these environments.

First environment

Residential buildings or locations at which the drive system is directly connected to a public low-voltage supply without intermediate transformer.

Second environment

All locations outside residential areas. These are basically industrial areas that have their own medium-voltage supply via their own transformers.

Categories

IEC/EN 61800-3 makes a distinction between four drive system categories:

Category C1

Drive systems for rated voltages < 1000 V for unrestricted use in the first environment.

Category C2

Stationary drive systems for rated voltages < 1000 V for operation in the second environment.

The drive system must be installed by appropriately qualified and trained personnel. Additional measures are required for operation in the first environment.

Category C3

Drive systems for rated voltages < 1000 V - only for operation in the second environment.

Category C4

Drive systems for IT line supplies for operation in complex systems in the second environment. An EMC plan must be drawn up.

12.3.3 Drive system applications

SINAMICS S120 units are designed for use in the second environment. They are to be used on a professional basis in trade, business and industry and are not sold to the general public.

In order to satisfy the EMC requirements, the drive system must be installed by appropriately qualified personnel in compliance with EMC regulations and the installation notes provided in the manual.

Note

Appropriately trained and qualified personnel

An appropriately trained and qualified person has the necessary experience for installing and/or commissioning drive systems (Power Drive Systems - PDS), including the associated EMC aspects.

Carefully observe the information in the "EMC installation guideline (<http://support.automation.siemens.com/WW/view/en/60612658/0/de>)" Configuration Manual for EMC-compliant installation.

With regard to interference immunity, the drive system is suitable for operation in the second environment.

Category C2

To ensure that the drive system satisfies the requirements of Category C2, you have to

- Use RFI suppression filters
- Operate drive system in a network with grounded neutral point
- Use motor cables with shielding and observe the maximum total line lengths:
 - ALM with HF reactor and Basic Line Filter up to 150 m
 - ALM with AIM and Basic Line Filter up to 350 m
 - SLM with line reactor and Basic Line Filter up to 350 m
 - BLM with line reactor and Basic Line Filter up to 350 m

Note

Conducted interference emissions above 1 MHz

In individual cases, additional measures may be necessary for the reduction of conducted interference emissions above 1 MHz. This applies in particular for operation of Motor Modules with 16 kHz pulse frequency at 720 V DC-link voltage.

All wires (three line conductors and the protective conductor) of the mains supply conductor to the control cabinet must be routed together through ferrite ring cores.

Series T60006 ring cores from VAC Vacuumschmelze featuring VITROPERM core material, for example T60006-L2080-W531, or similar ring cores from other manufacturers are recommended in this regard.

Category C3

To ensure that the drive system satisfies the requirements of Category C3, you have to

- Use RFI suppression filters
- Operate drive system in a network with grounded neutral point
- Use motor cables with shielding and observe the maximum total line lengths:
 - ALM with AIM up to 350 m
 - BLM with line reactor up to 350 m
 - BLM with line reactor and Basic Line Filter up to 630 m

Category C4

The following combinations are permissible for operation in IT systems (Category C4):

- ALM with HF reactor without Line Filter
- ALM with AIM (remove connecting screw for interference suppression capacitor)
- SLM with line reactor without Line Filter
- BLM (remove the connection bracket for interference suppression capacitor) with line reactor without Line Filter

Note

Special characteristics of networks which are not grounded at the neutral point

The following conditions apply for operation in networks which are not grounded at the neutral point (e.g. IT systems or networks with grounded line conductor):

- Basic Line Filters may not be used
- For Active Interface Modules and Basic Line Modules, the connection screw or the connection bracket to the radio interference suppression capacitor with respect to ground must be removed.
- In conjunction with Smart Line Modules, to reduce symmetrical interference emission, special filters can be used (without capacitors to ground).

Note

Integrating SINAMICS S120 in other plants/machines

When variable-speed drive systems are integrated in other plants/machines, additional measures may be required in order to comply with their product standards.

Note

Malfunctions when not using original Siemens accessories

Malfunctions can occur if accessories are used that are not original.

- Only use original "MOTION-CONNECT cables (Page 683)" for DRIVE-CLiQ connections and the couplings and cabinet bushings described in Chapter "Accessories (Page 631)".
-

Note

Faulty operation of the machine due to incorrect shielding or cables that are too long

The machine can malfunction if the shielding is incorrect or the cables are too long.

- Always follow the correct procedures for the shielding and the specified cable lengths.
-

12.4 Arrangement of components and equipment

12.4.1 General information

The arrangement of the components and equipment depends on the following conditions:

- Space requirements
- Cable routing
- Bending radii of the connecting cables
MOTION-CONNECT cables, refer to catalog PM21 or NC61
- Heat dissipation
- EMC

The components of the drive line-up should preferably be installed on a conductive mounting surface to ensure low impedance between the component and the mounting surface. Mounting plates with a galvanized surface are suitable.

Components are usually located centrally in a cabinet. The necessary mounting and installation clearances above and below the components can possibly exceed the minimum clearances specified in the product documentation.

The components can be arranged in one or more tiers. In a multiple-tier arrangement, vertical mounting or, in a cabinet row, side-by-side mounting in different cabinet sections is possible.

To determine the cross-section, the DC-link busbar current carrying capacity is used as basis, which is specified in the relevant technical data.

A ventilation clearance of 100 mm must be maintained around the line reactor (not including the mounting surface).

12.4.2 Current carrying capacity of the DC link busbar

The current carrying capacity of the DC link busbar must be observed for the configuration and arrangement of the drive line-up. The maximum current carrying capacity of the DC link busbar differs for the various module widths.

Table 12- 1 Maximum current carrying capacity of the DC link busbar

Current carrying capacity of the DC link busbar	Components
100 A	<ul style="list-style-type: none"> • Motor Modules from 50 mm to 100 mm wide • DC link components
150 A	<ul style="list-style-type: none"> • Motor Modules from 50 to 100 mm wide with reinforced DC link busbars
200 A	<ul style="list-style-type: none"> • Motor Modules from 150 to 300 mm wide

To calculate the load of the DC link busbar, add the DC link currents I_d of the connected Motor Modules. If the current carrying capacity of the DC link busbars is exceeded for the planned configuration, two solutions are possible:

- Center infeed: Arrangement of the drive line-up with infeed to the left and right (example 2)
- Use of another Line Module

Note

The following examples are based on the simultaneous use and loading of the Motor Modules with the rated current I_n . The values of the DC link current were taken from the technical data of the Motor Modules in the Power Units Booksize Manual.

Example 1:

Connection of several Motor Modules with different current carrying capacity of the DC link busbar to a Line Module.

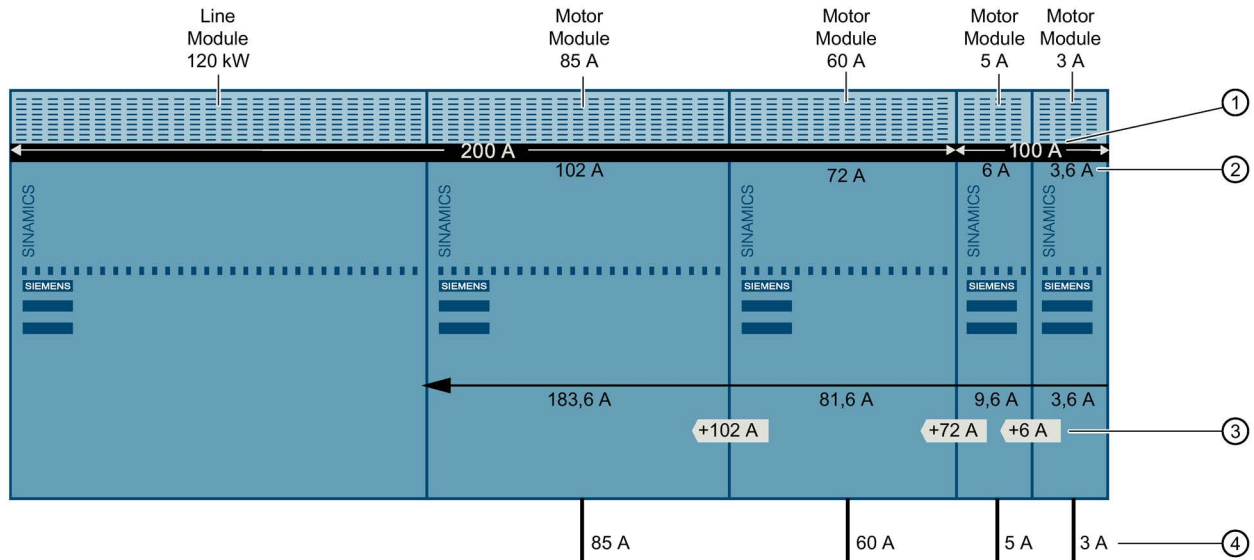

- ① DC link busbar current carrying capacity
- ② DC link busbar load: DC link current I_d at the rated current I_n of the Motor Module
- ③ Increased load of the DC link busbar
- ④ Motor current = rated output current I_n of the Motor Module

Figure 12-1 Regular arrangement with infeed to the right of the DC link, DC link busbar not overloaded

Example 2:

Connection of several Motor Modules with different current carrying capacity of the DC link busbar to a Line Module with center infeed

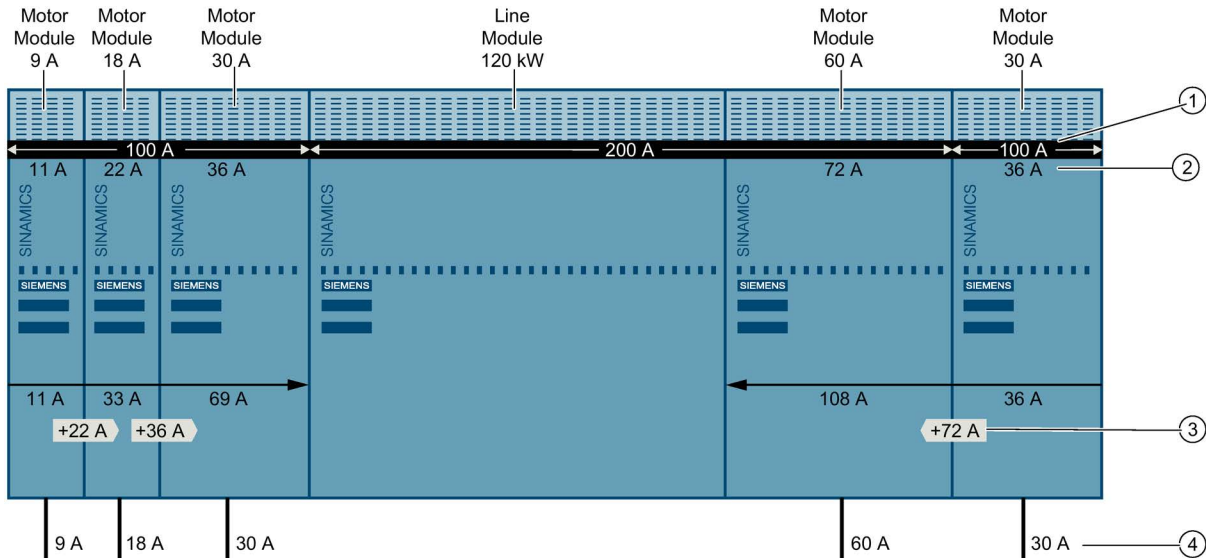

- ① DC link busbar current carrying capacity
- ② DC link busbar load: DC link current I_d at the rated current I_n of the Motor Module
- ③ Increased load of the DC link busbar
- ④ Motor current = rated output current I_n of the Motor Module

Figure 12-2 Center infeed - infeed from left and right to the DC link

A center infeed with Motor Modules to the right and left of the Line Module can be configured for all Line Modules in compliance with current carrying capacity.

Exception: Smart Line Modules 5 kW and 10 kW

Note

For Smart Line Modules 5 kW and 10 kW, the arrangement of the drive line-up must be made to the right!

12.4.3 Single-tier drive line-up

Due to the current carrying capacity of the DC-link busbars and their function in particular, the components should be arranged according to the following rule. From left to right:

- Line Module
- Motor Modules in order of power from the highest power to the lowest power
- DC link components, e.g. Braking Module, Control Supply Module, Capacitor Module

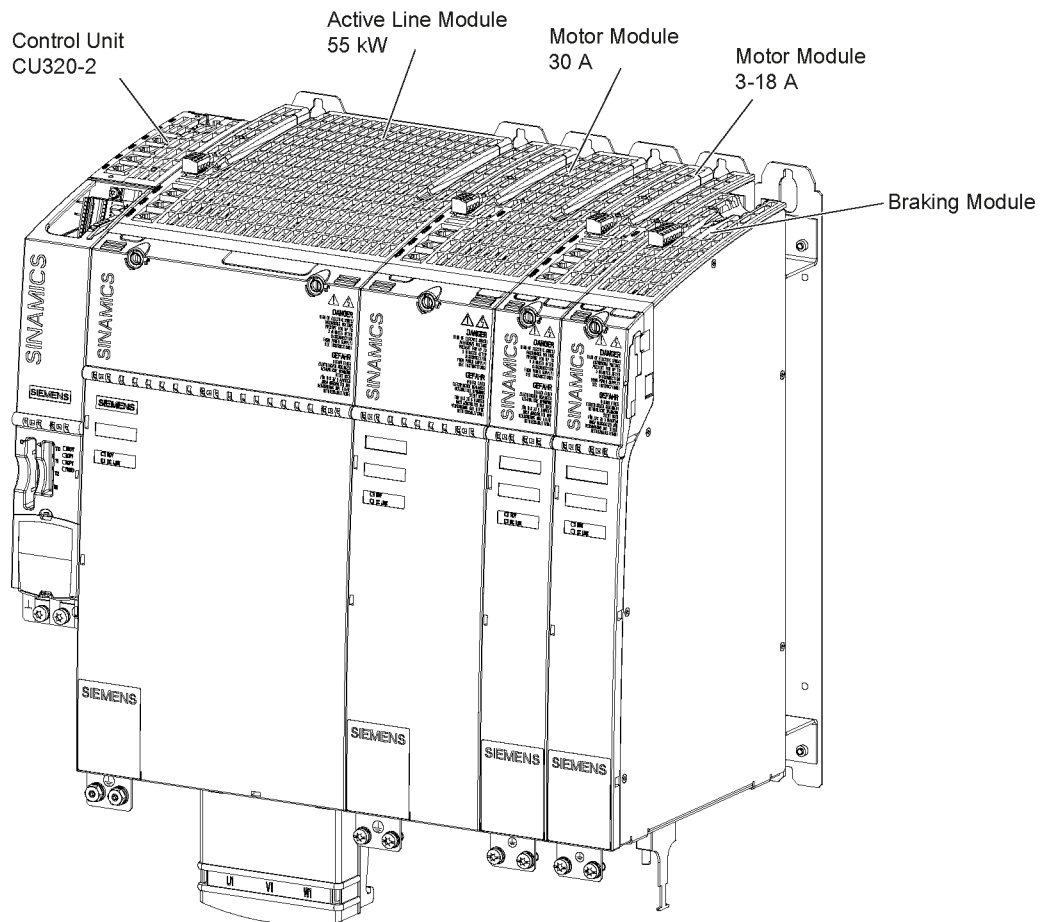

Figure 12-3 Example of a single drive line-up with internal air cooling

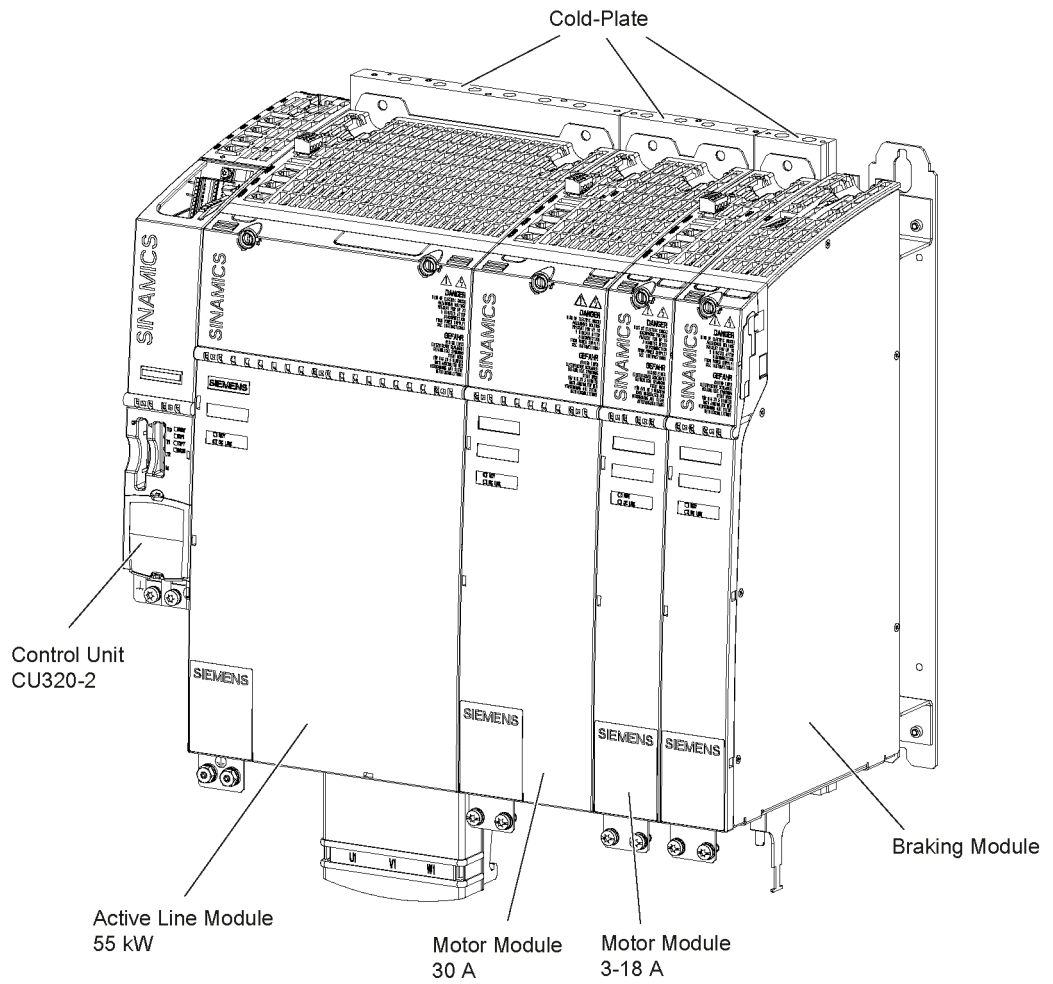

Figure 12-4 Example of a single drive line-up with cold plate

12.4.4 Multi-tier drive line-up

12.4.4.1 Arrangement rules

The following points must be observed for the arrangement of a multi-tier drive line-up:

- The individual wires must be shielded, and the shield must be attached at both ends.
- The DC link is continued outside the components using the DC link adapter (for information on mounting, see Chapter Accessories (Page 569)) and single conductor, finely-stranded, shielded cables.
The cables must be laid according to IEC 61800-5-2 so that a ground fault or short-circuit is completely ruled out.
- The distance between the tiers of modules primarily depends on the wiring, the cable cross-section and the bending radius of the power cables to be connected.
- The inlet temperature of the air sucked in for cooling the module must not exceed 40° C (with derating, it must not exceed 55° C). This must be ensured by means of suitable air guidance, the distance between the module rows, or by air baffle plates.

Note

Operating faults due to incorrectly laid cables

Particularly with regard to satisfying the EMC requirements, signal cables should not be laid parallel to power cables.

Note

Arrangement of the components for infeed of the DC link voltage from the right

If the infeed is on the right-hand side of the drive line-up (e.g. in a multi-tier configuration), the rules described in Chapter Single-tier drive line-up (Page 652) apply in the inverse sequence.

This means:

- Arrangement of the Motor Modules depending on their power, starting with the highest power
 - DC link components, such as Braking Modules, at the end of the tier
-

Note

Wiring rules for DRIVE-CLiQ

See SINAMICS S120 Commissioning Manual, Chapter "Rules for wiring with DRIVE-CLiQ".

12.4.4.2 Selecting the DC link rectifier adapter and DC link adapter

Table 12- 2 Overview of the DC link rectifier adapter and DC link adapter

	Suitable for module width	Max. connectable cross-section	Max. current carrying capacity
DC link rectifier adapter (cable outlet on top)			
6SL3162-2BD00-0AA.	50 mm, 100 mm	10 mm ²	43 A
6SL3162-2BM00-0AA.	150 mm, 200 mm, 300 mm	95 mm ²	240 A
DC link adapter (cable outlet on side)			
6SL3162-2BM01-0AA.	All module widths	95 mm ²	240 A
6SL3162-2BM10-0AA.	50 mm, 100 mm	95 mm ²	150 A

Note

Using DC link adapters

DC link adapters are only required to configure a multi-tier drive line-up.

12.4.4.3 Connection versions for the DC link adapter

Depending on the technical requirements and the space available in the control cabinet, for multi-tier drive line-ups, there are different options when it comes to connecting the DC-link adapter.

Note

Special feature: Short DC-link screws

Because of the compact construction and the required voltage separations, the left-hand DC-link screws are shorter (16 mm) than the other DC-link screws (20 mm) for modules with 50-100 mm installation width.

Note

Special feature: Different number of DC-link screws

Modules with an installation width of 200 mm or larger require two screws per DC-link busbar on the right-hand DC-link connection side in order to carry the higher amperages.

Note

Special feature: Washers during installation of the DC-link adapter

The supplied washers must also be installed on the left-hand side during the installation of the DC-link adapter for modules with an installation width of 150 mm or greater.

Table 12- 3 Comparison of the connection versions

Var.	Module width [mm]	Installation	Current-carrying capacity of the DC-link busbar [A]	DC-link adapter 6SL3162-...	DC-link busbar	Fastening of the DC-link adapter to two DC-link busbars	Screws	Washers
1	50 ... 100	Right	≤ 100	2BM01-0AA0	Standard	2 screws	M4x20	No
2	50 ... 100	Right	≤ 150	2BM10-0AA0	Reinforced	2 screws	M4x20	No
3	50 ... 100	Left	≤ 100	2BM01-0AA0	Standard	2 screws	M4x16	No
4	150	Right	≤ 150	2BM01-0AA0	Standard	2 screws	M4x20	No
5	150 ... 300	Left	≤ 150	2BM01-0AA0	Standard	2 screws	M4x20	Yes
6	200 ... 300	Right	≤ 200	2BM01-0AA0	Standard	4 screws	M4x20	No

Connections as cross-sectional drawings (view from below)

Note

The different connection versions of the DC-link adapter are shown in the following cross-sectional drawings. Special features are highlighted in bold in the table above.

Variant 1: Module width 50-100 mm, connected to the drive line-up from the right, standard DC-link busbar

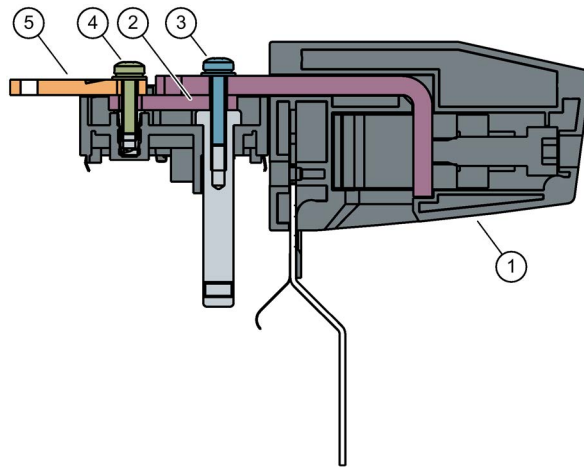

- ① DC-link adapter 6SL3162-2BM01-0AA0 (4 hole)
- ② Standard DC-link busbar (4 mm)
- ③ Connecting the DC-link adapter to the module using 2 M4x20 screws
- ④ Connecting the DC-link busbar to the module using 2 M4x16 screws
- ⑤ DC-link bridge

Figure 12-5 Variant 1 (representation from below)

Variant 2: Module width 50-100 mm, connected to the drive line-up from the right, reinforced DC-link busbar

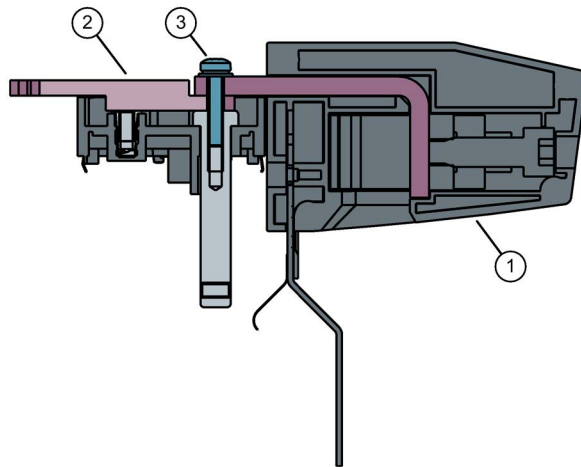

- ① DC-link adapter 6SL3162-2BM10-0AA0 (2 hole)
- ② Reinforced DC-link busbar (8 mm)
- ③ Connecting the DC-link adapter to the DC-link busbar using 2 M4x20 screws

Figure 12-6 Variant 2 (representation from below)

Variant 3: Module width 50-100 mm, connected to the drive line-up from the left, standard DC-link busbar

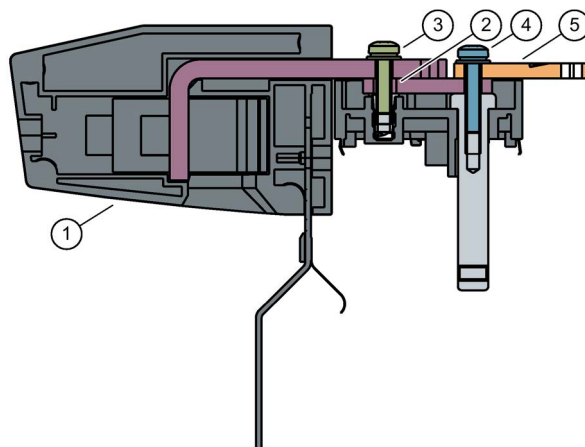

- ① DC-link adapter 6SL3162-2BM01-0AA0 (4 hole)
- ② Standard DC-link busbar (4 mm)
- ③ Connecting the DC-link adapter to the module using 2 M4x16 screws
- ④ Connecting the DC-link busbar to the module using 2 M4x20 screws
- ⑤ DC-link bridge

Figure 12-7 Variant 3 (representation from below)

Variant 4: Module width 150 mm, connected to the drive line-up from the right, standard DC-link busbar

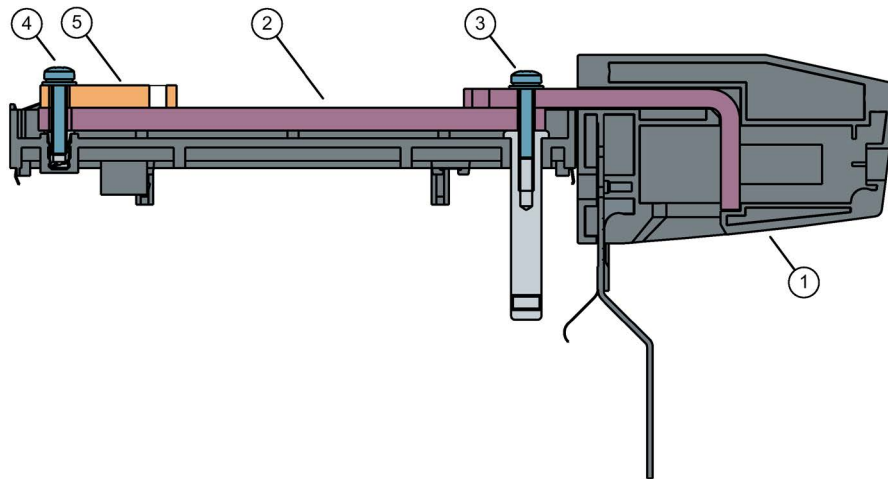

- ① DC-link adapter 6SL3162-2BM01-0AA0 (4 hole)
- ② Standard DC-link busbar (6 mm)
- ③ Connecting the DC-link adapter to the module using 2 M4x20 screws
- ④ Connecting the DC-link busbar to the module using 2 M4x20 screws
- ⑤ DC-link bridge

Figure 12-8 Variant 4 (representation from below)

Variant 5a: Module width 150 mm, connected to the drive line-up from the left, standard DC-link busbar

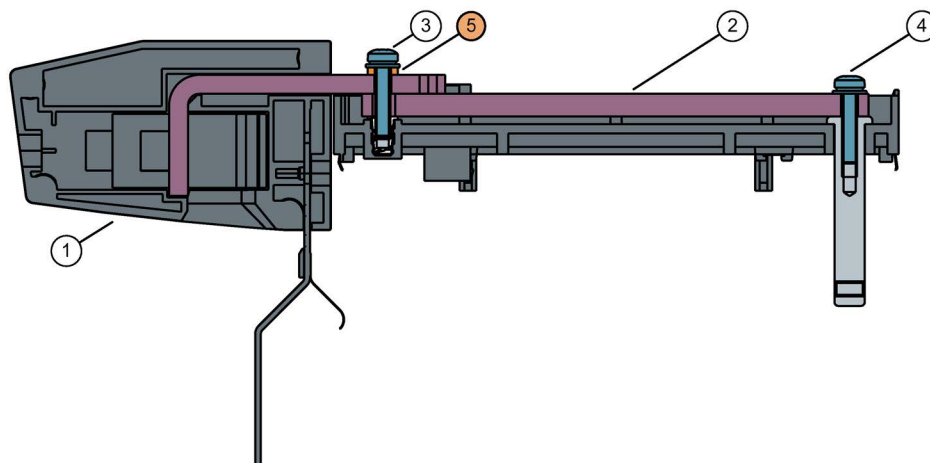

- ① DC-link adapter 6SL3162-2BM01-0AA0 (4 hole)
- ② Standard DC-link busbar (6 mm)
- ③ Connecting the DC-link adapter to the module using 2 M4x20 screws
- ④ Connecting the DC-link busbar to the module using 2 M4x20 screws
- ⑤ Washer

Figure 12-9 Variant 5a (representation from below)

Variant 5b: Module width 200-300 mm, connected to the drive line-up from the left, standard DC-link busbar

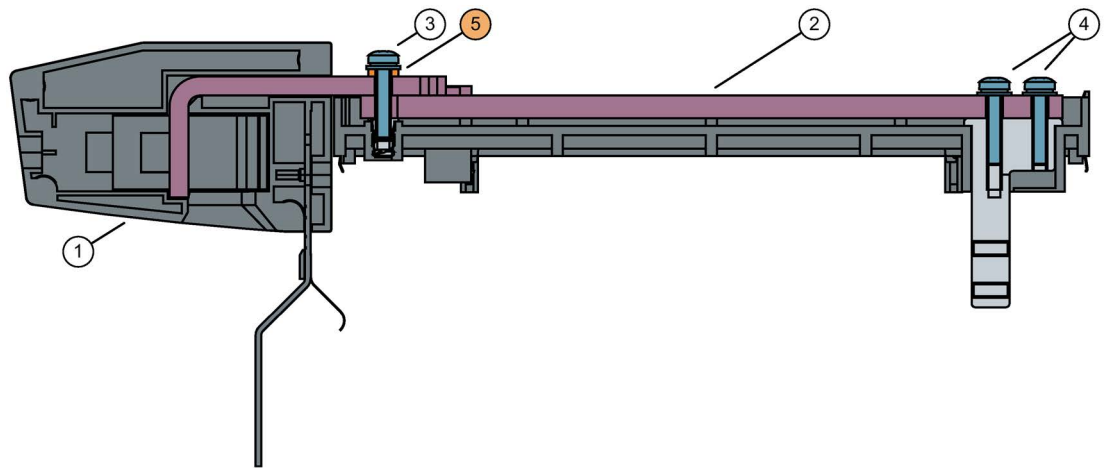

- ① DC-link adapter 6SL3162-2BM01-0AA0 (4 hole)
- ② Standard DC-link busbar (6 mm)
- ③ Connecting the DC-link adapter to the module using 2 M4x20 screws
- ④ Connecting the DC-link busbar to the module using 4 M4x20 screws
- ⑤ Washer

Figure 12-10 Variant 5b (representation from below)

Variant 6: Module width 200-300 mm, connected to the drive line-up from the right, standard DC-link busbar

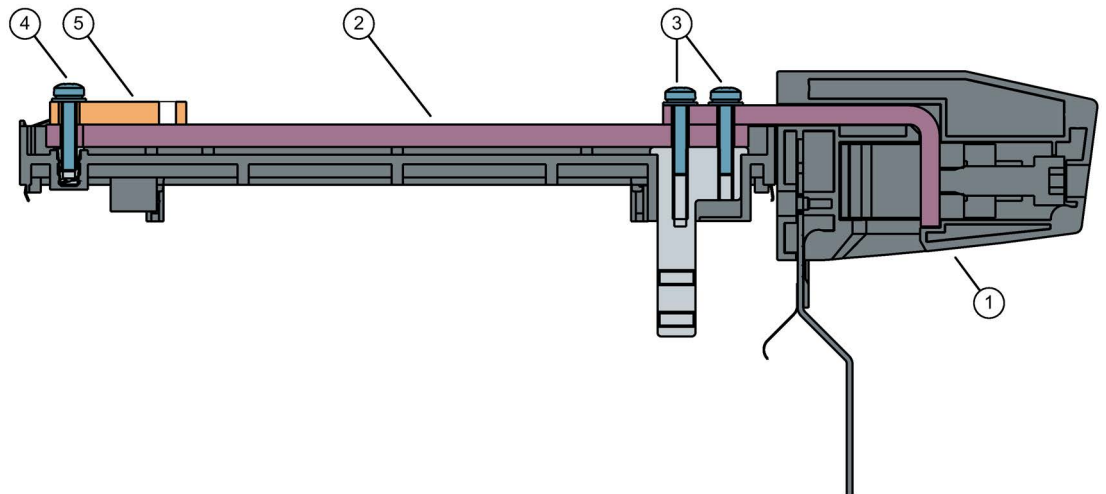

- ① DC-link adapter 6SL3162-2BM01-0AA0 (4 hole)
- ② Standard DC-link busbar (6 mm)
- ③ Connecting the DC-link adapter to the module using 4 M4x20 screws
- ④ Connecting the DC-link busbar to the module using 2 M4x20 screws
- ⑤ DC-link bridge

Figure 12-11 Variant 6 (representation from below)

12.4.4.4 Examples of a multi-tier configuration

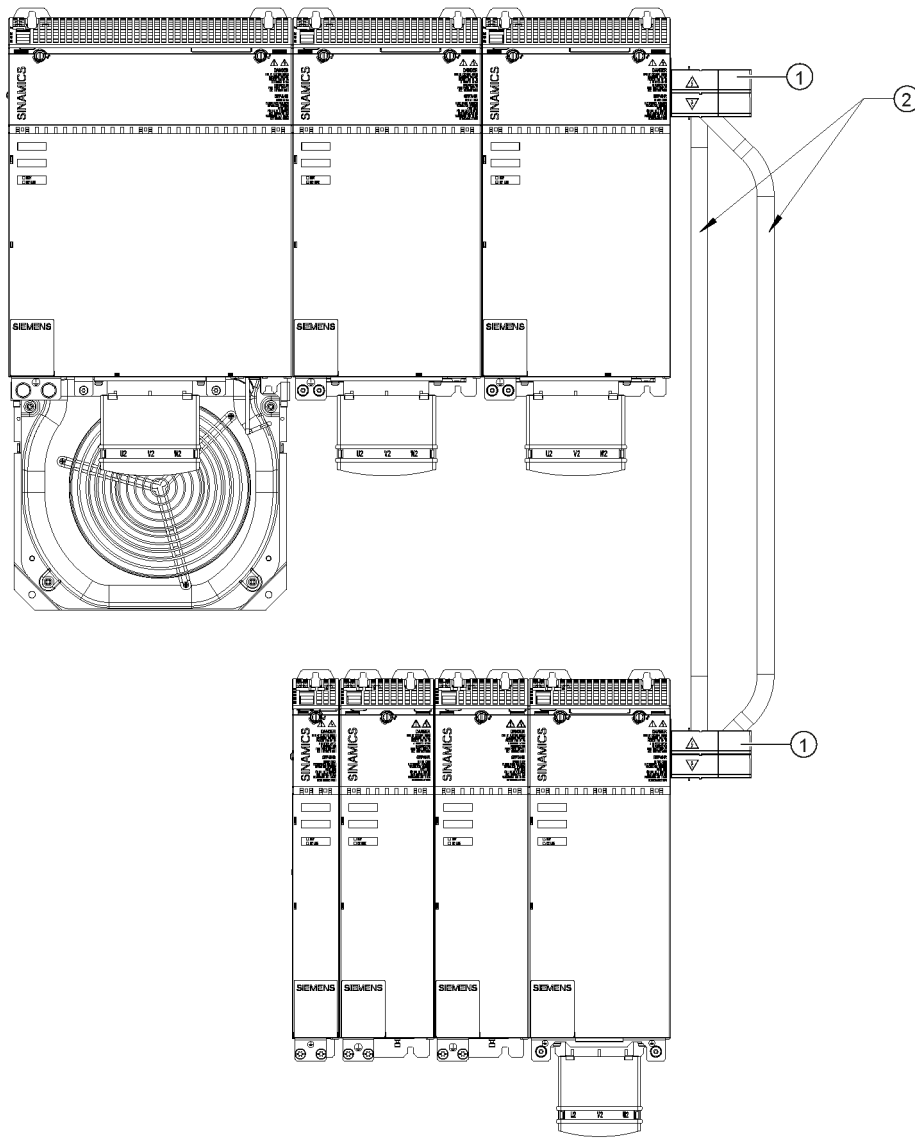

- ① DC link adapter
- ② Power cable shielded

Figure 12-12 Example of a two-tier configuration for a drive line-up with internal air cooling

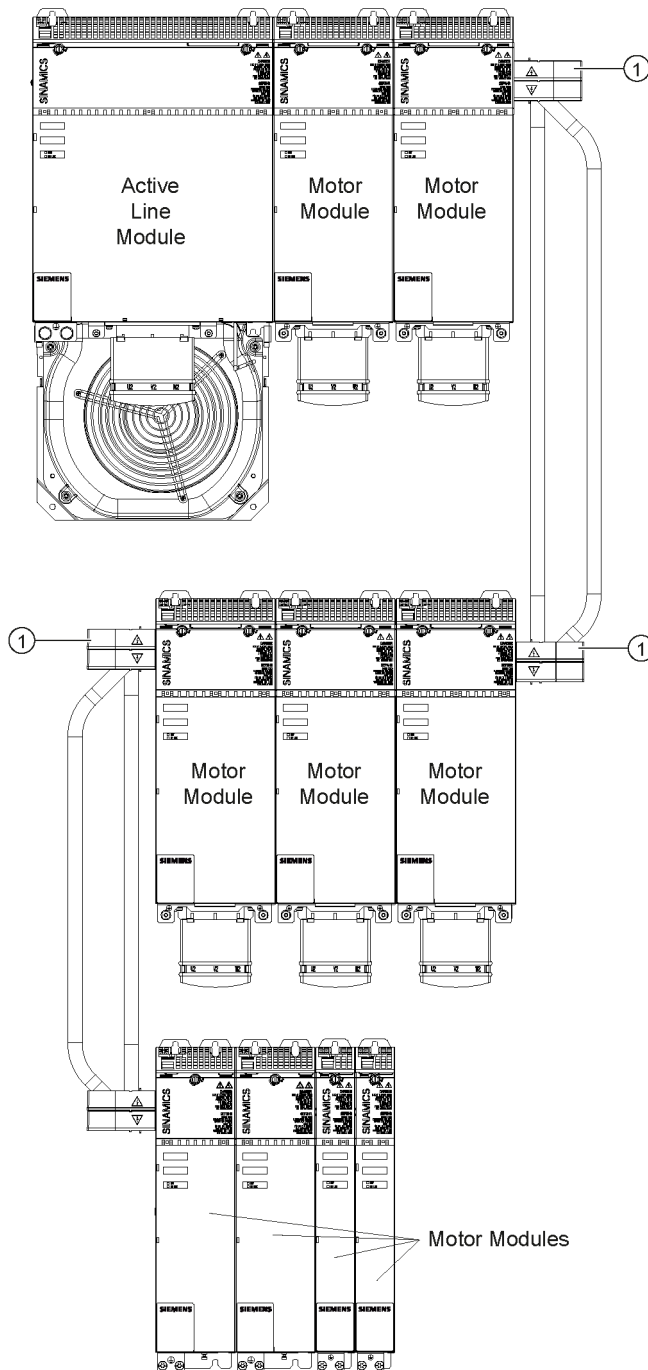

① DC link adapter

Figure 12-13 Example of a three-tier configuration for a drive line-up with internal air cooling

12.4.4.5 Connection example

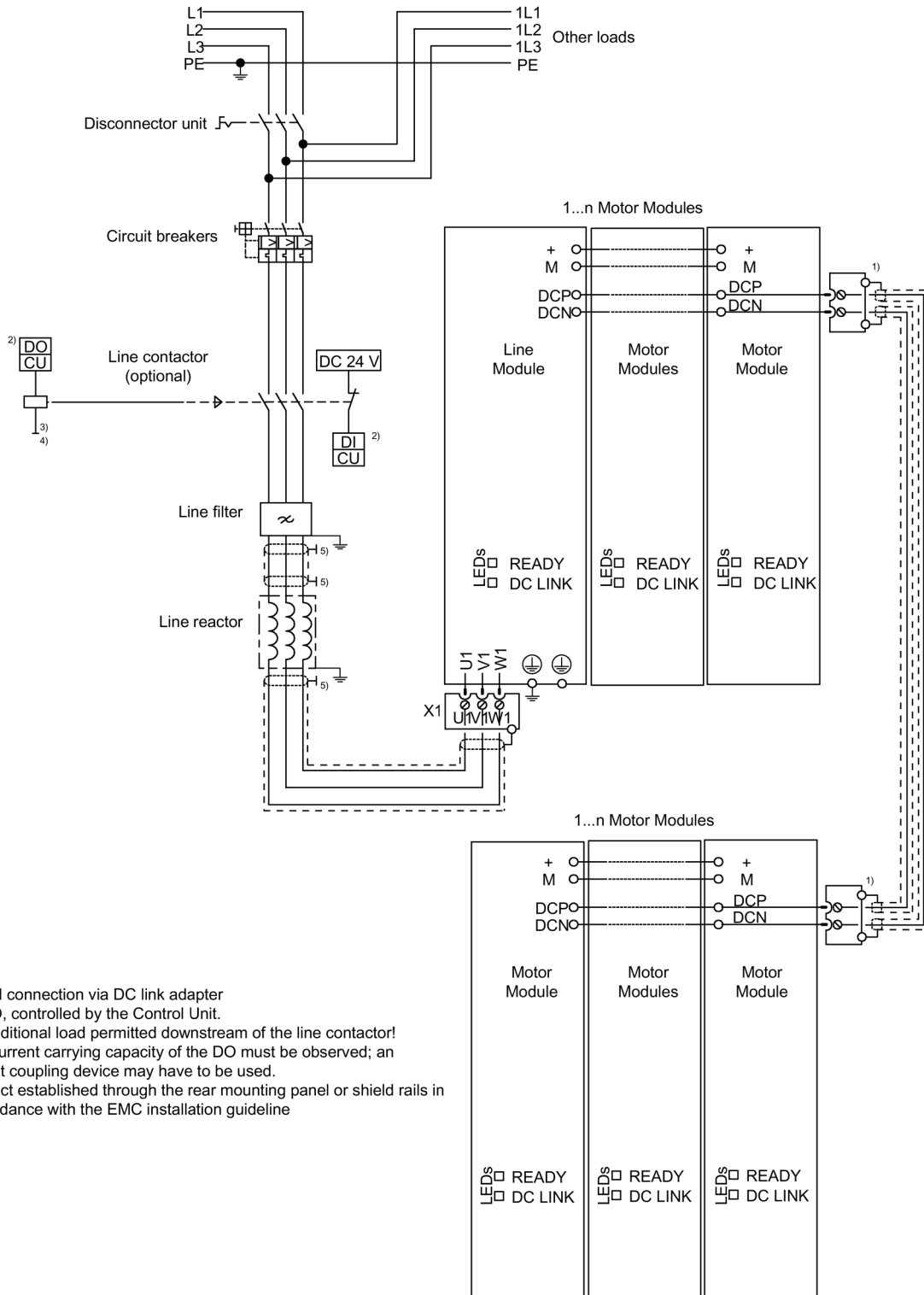

- ¹⁾ Shield connection via DC link adapter
- ²⁾ DI/DO, controlled by the Control Unit.
- ³⁾ No additional load permitted downstream of the line contactor!
- ⁴⁾ The current carrying capacity of the DO must be observed; an output coupling device may have to be used.
- ⁵⁾ Contact established through the rear mounting panel or shield rails in accordance with the EMC installation guideline

Figure 12-14 Connection example for a two-tier drive line-up

12.5 Electrical connection

12.5.1 Connecting DC link busbars

The DC link busbars and 24 V busbars of the components must be connected in a drive line-up before commissioning. Note the information about the arrangement of the components as well as the current carrying capacity of the DC link busbars in the previous sections. The connection of components with reinforced DC link busbars is described in Chapter Reinforced DC link busbars (Page 599).



! WARNING

Electric shock due to incorrectly installed DC link bridges

Incorrectly installed DC link bridges **at the left-hand end of the drive line-up** can cause an electric shock.

- For all 50 mm wide modules¹⁾ (exception: Smart Line Module²⁾), remove the DC link bridge, including the screws. Do not tighten the screws without the DC link bridges.
- For all components that are 75 mm wide or wider, the DC link bridges must not be moved to the left or removed³⁾.

¹⁾ For 50 mm wide modules, the DC link bridge cannot be swung inwards.

²⁾ Smart Line Modules do not have a DC link bridge.

³⁾ The DC link bridge guarantees the mechanical stability of the DC link busbars.

NOTICE

Damage of the devices caused by the use of unsuitable screws

Using unsuitable screws to attach the DC link busbar for components with widths of between 50 and 100 mm can result in damage to the devices.

- Only use the original M4x16 screws on the left-hand side of the module.
- Only use the original M4x20 screws on the right-hand side of the module.
- For module widths of 150 mm and higher, only use M4x20 screws.

12.5 Electrical connection

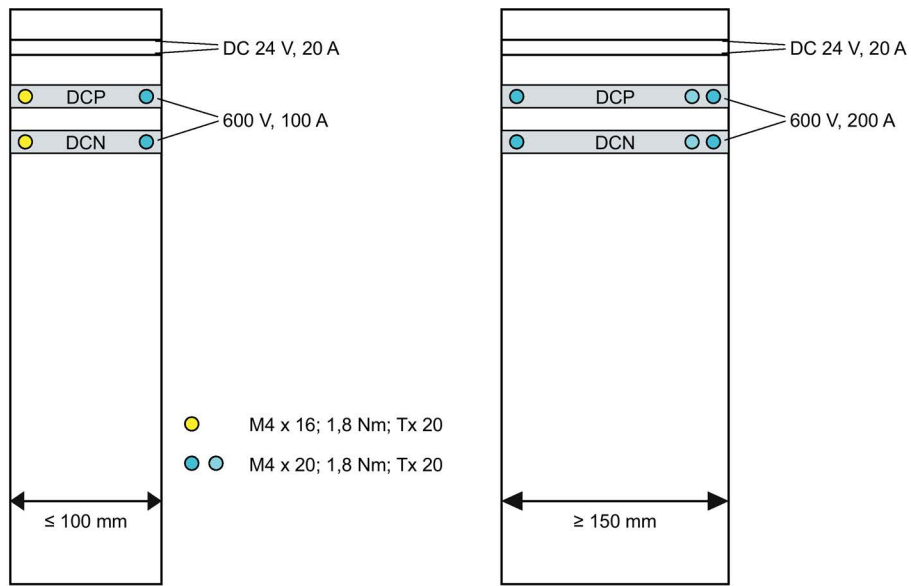

Figure 12-15 DC link busbar screw connections dependent on the module width

The connection of a Line Module to a Motor Module is shown in the following.

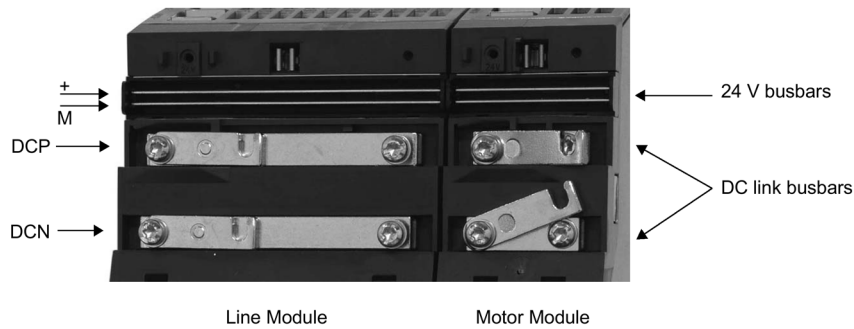

Figure 12-16 Line Module and Motor Module as delivered

Connecting DC link busbars

Always connect the lower DC link busbars first and then the upper DC link busbars.

Tool: Screwdriver Torx T20

Working steps:

1. Loosen the DC link busbar screws.
2. Turn over the DC link bridge.

3. Fasten the DC link screws with a tightening torque of 1.8 Nm (15.9 lbf in). It is essential that you follow the sequence shown below (1 and 2).
4. Tighten the DC link screw on the right-hand side of the module for the components of the drive line-up arranged on the far right with a tightening torque of 1.8 Nm (15.9 lbf in). The power connection of the DC link busbar with the module is established via the right-hand screw mounting (3).

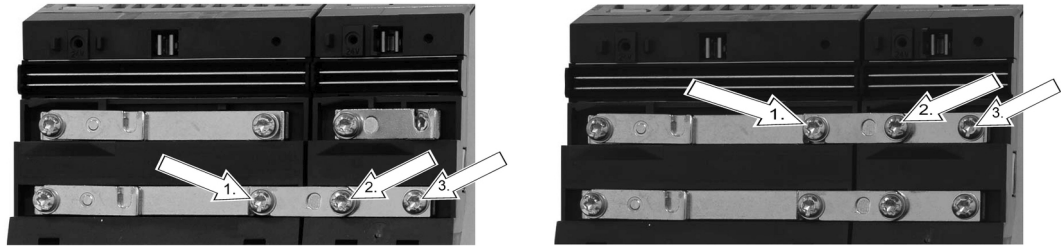

1. Connection of the lower DC link busbars

2. Connection of the upper DC link busbars

DC link connections as cross-sectional drawings (view from below)

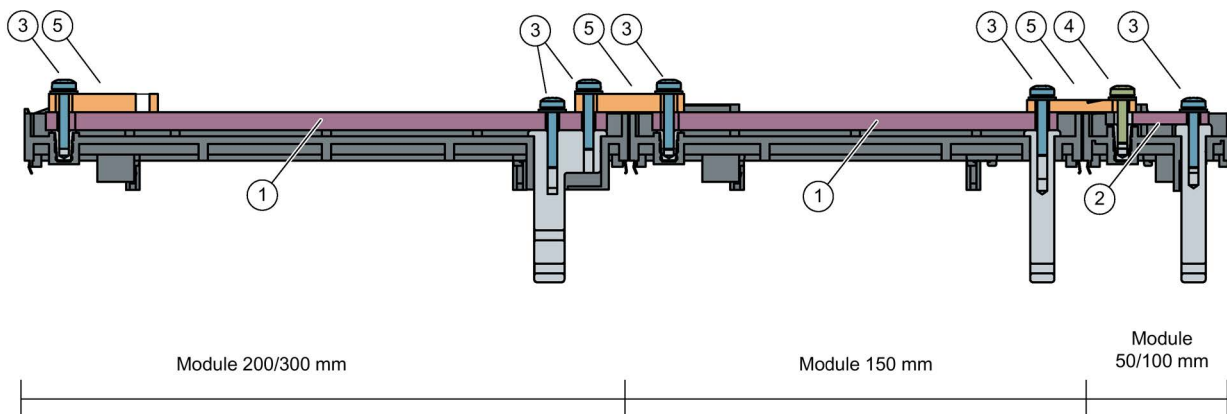

- ① Standard DC link busbar (6 mm)
- ② Standard DC link busbar (4 mm)
- ③ Connecting the DC link busbar to the module using a M4x20 screw
- ④ Connecting the DC link busbar to the module using a M4x16 screw
- ⑤ DC link bridge

Figure 12-17 DC link busbar connection using a standard DC link busbar at a 50/100 mm module

12.5 Electrical connection

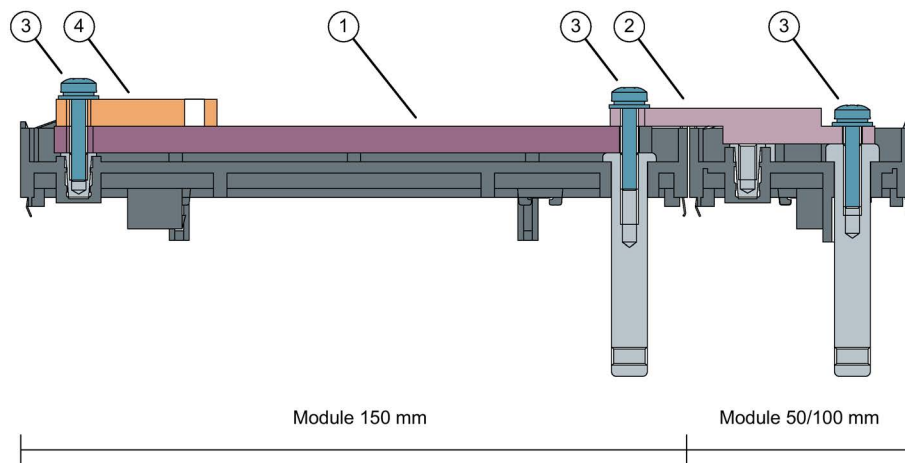

- ① Standard DC link busbar (6 mm)
- ② Reinforced DC link busbar (8 mm)
- ③ Connecting the DC link busbar to the module using a M4x20 screw
- ④ DC link bridge

Figure 12-18 DC link busbar connection using a reinforced DC link busbar at a 50/100 mm module

12.5.2 Connection of the 24 V busbars

Connection of the 24 V busbars

The 24 V busbars of the components are connected using the 24 V connectors provided in the accessories pack. A 24 V connector must be plugged onto the 24 V busbars between the Line Module, Motor Module and DC link component. The 24 V connectors must be attached before the drive line-up is commissioned!

Working steps:

1. Place the 24 V connectors on to the 24 V busbars.
2. Press the 24 V connectors down until they click into place.
3. If required, mount the 24 V terminal adapter to supply the 24 V DC.



- ① Mounted 24 V terminal adapter (Torx T10, tightening torque 0.5 Nm (4.4 lbf in))
- ② Mounted 24 V connector

WARNING

Fire hazard for 24 V connectors and unconnected DC link busbars

For drive lineups in series, whose DC link busbars are not connected with one another, it is not permissible to insert 24 V connectors between these drive lineups. Otherwise the 24 V connectors can burn and cause severe injury or death as result of fire or smoke.

- If the DC link busbars of the components are not connected, each component must be supplied with 24 V separately via a 24 V terminal adapter.



WARNING

Electric shock when connecting and disconnecting 24 V connections during operation

When opening plug connections in operation, arcs can result in severe injury or death.

- Only withdraw or insert the 24 V connectors in a no-voltage state.

12.5.3 Installation of the 24 V terminal adapter

The 24 V terminal adapter can be installed in every Line Module, Motor Module and Control Supply Module.

The 24 V terminal adapter is suitable for connecting cable cross-sections of 0.5 up to 6 mm². The 24 V terminal adapter is included in the scope of delivery of Line Modules and Control Supply Modules. It can be ordered as replacement part (article number: 6SL3162-2AA00-0AA0).

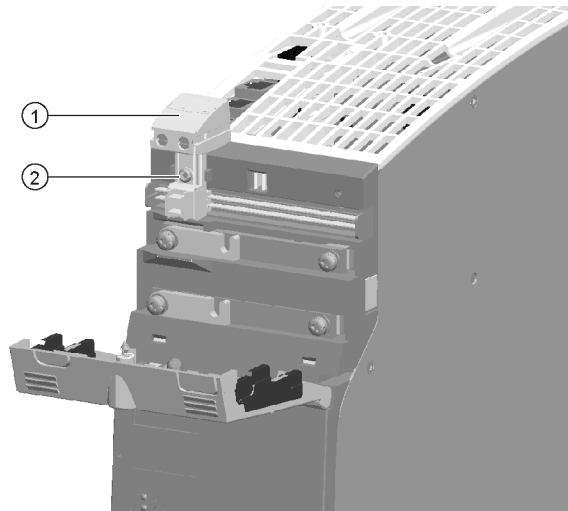

- ① 24 V terminal adapter
- ② Screw for fixing: SHR, PT-TORX K30-3, 0X16-ST-A2F WN1452 / EJ company
Tightening torque: 0.5 Nm (4.4 lbf in)

NOTICE

Damage to the 24 V connector as a result of incorrect insertion/withdrawal





Incorrect insertion/withdrawal of the 24 V connector can damage it.

- Only withdraw the 24 V terminal adapter vertically in relation to the front plate.
- It is only permissible to withdraw or insert the 24 V connectors a maximum of 5 times.

You require the following tools to install the 24 V terminal adapter:

- Slot-head screwdriver 1 x 5.5 for releasing the protective cover
- Torx T10 screwdriver to fasten the 24 V terminal adapter
- Suitable pliers to break out the cutout in the protective cover

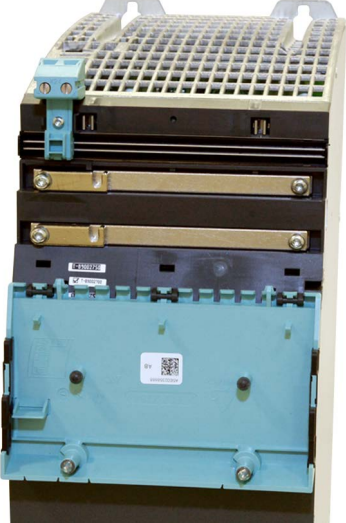
Table 12- 4 Installing the 24 V terminal adapter using an Active Line Module (36 kW) as example

		
<p>Release the protective cover.</p>	<p>Open the protective cover.</p>	<p>Clip the 24 V terminal adapter on to the 24 V busbars. Screw the 24 V terminal adapter tight with the supplied screw. Tightening torque: 0.5 Nm (4.4 lbf in)</p>
		
<p>Break out the cutout in the protective cover.</p>	<p>Close the protective cover. The protective cover must latch into place audibly.</p>	



⚠ WARNING

Electric shock if the cutout in the protective cover has been broken out

Live components are open and accessible if the 24 V terminal adapter or the DC link infeed adapter are removed. Touching live components can result in death or severe injury.

- Replace the protective cover with the broken out cutouts by a new protective cover.

Note

The 24 V terminal adapter should be installed to the left of the component located at the far left, because if it is positioned anywhere else there may not be enough space for the 24 V plug-in jumpers.

If necessary, the 24 V terminal adapter can also be located at the right for 50 mm and 100 mm modules.

12.5.4 Shield connection for terminals X21/X22 on the Motor Module

The diagram below shows a typical shield connection terminal for the shield support of the cables to terminal X21.

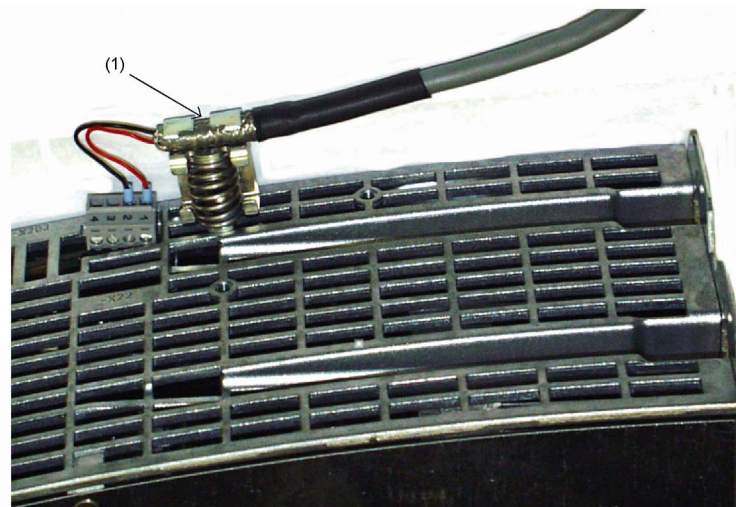

① Shield connection clamp: Weidmüller, type KLBÜ 3-8 SC

Figure 12-19 Shield connection terminal for the shield support

**! WARNING****Electric shock due to impermissible screw length**

Excessively long screws can come into contact with live parts and can therefore result in death or serious injury.

- Only use screws with a permissible insertion depth of 4 - 6 mm.

12.6 24 V DC supply voltage

12.6.1 General information

The 24 V DC voltage is required for:

- To supply the electronics of the SINAMICS components via the integrated 24 V busbar
- To supply the electronics of the Control Units, Option Boards, Sensor Modules, and Terminal Modules, as well as the process voltage of their digital inputs
- To supply the load voltage of the digital outputs
- To supply the motor holding brakes

Other loads can be connected to these power supply units if they are separately protected from overcurrent.

Note

The electronics power supply should be implemented by the user, as described in Chapter System data (Page 42).

When connecting a DC power supply as specified in EN 60204-1:1997, Sect. 4.3.3, malfunctions may occur due to the voltage interruptions permitted for them.

Note**Grounding the 24 V electronics power supply**

In SINAMICS S120 components, the electronics ground is permanently connected to the protective conductor potential. The connection cannot be disconnected.



! WARNING

Electric shock due to incorrectly laid brake cables

If brake cables are laid without safe electrical separation, the insulation can fail and cause an electric shock.

Install the brake in one of the following ways:

- Connect the holding brake with the specified MOTION-CONNECT cable.
- Only use third-party cables with safe electrically separated brake cores or lay the brake cores with safe electrical separation.

NOTICE

Damage to other loads as a result of overvoltage

Overvoltage of switched inductances (contactors, relays) can damage connected loads.

- Install suitable overvoltage protection circuits and devices.

Note

Malfunction because 24 V supply voltage is too low

If the 24 V supply voltage falls below the specified minimum value on a device in the assembly, a malfunction can occur.

- Select an input voltage that is high enough for there to be sufficient voltage at the last device. Do not exceed the maximum value for the supply voltage. If required, supply the voltage to the assembly at various locations in the lineup.

Note

Motor holding brake connection

To ensure reliable opening of the motor holding brake, it requires a 24 V \pm 10% voltage supply at the motor connection. It must be taken into account that voltage dips can occur along the supply cable.

- Use a Control Supply Module or a regulated DC power supply, whose setpoint is set to 26 V.
- Use supply cables with a minimum cross-section of 1.5 mm² and a maximum length of 100 m.

Protective circuit against overvoltage

The Motor Modules have an integrated overvoltage protection circuit for the motor holding brake. External protective circuits are not required.

12.6.2 Options for the 24 V supply of the components

In a drive line-up, the Line Modules, Motor Modules and DC link components are connected to the 24 V power supply via the integrated 24 V busbars. The current carrying capacity of these busbars is 20 A. The 24 V infeed can be realized in two ways:

- Using a Control Supply Module
- Using an external 24 V power supply

Using a Control Supply Module

When a Current Supply Module is used, the 24 V supply is directly established via the busbars. The electronic current limiting function integrated in the Control Supply Module protects the busbar system when a fault occurs. Additional loads can be connected via the 24 V terminal adapter.

Note

If you use cables with a cross-section of 2.5 mm², no additional protection is required on the 24 V side for the following cable types:

- Cables of the XLPE type
- Cables of the EPR type
- Cable with a similar properties and which is thermally stable up to 90 °C

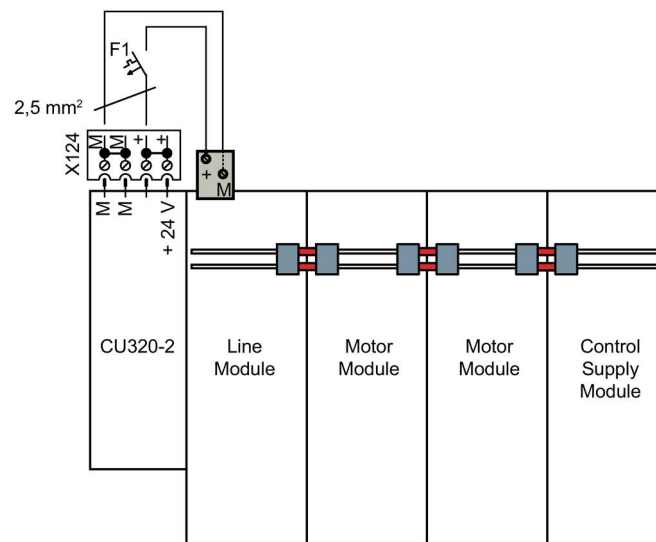

Figure 12-20 Example of a 24 V supply via a Control Supply Module

Using an external 24 V power supply

When using an external 24 V power supply, e.g. SITOP, the 24 V terminal adapter must be used. The external power supply should be located very close to the load. Surge arresters are required for cables longer than 30 m (see Chapter "Surge protection (Page 675)").

We recommend using miniature circuit breakers with tripping characteristic D as overcurrent protection devices for the cables and busbars. The ground potential M must be connected to the protective conductor system (PELV/SELV).

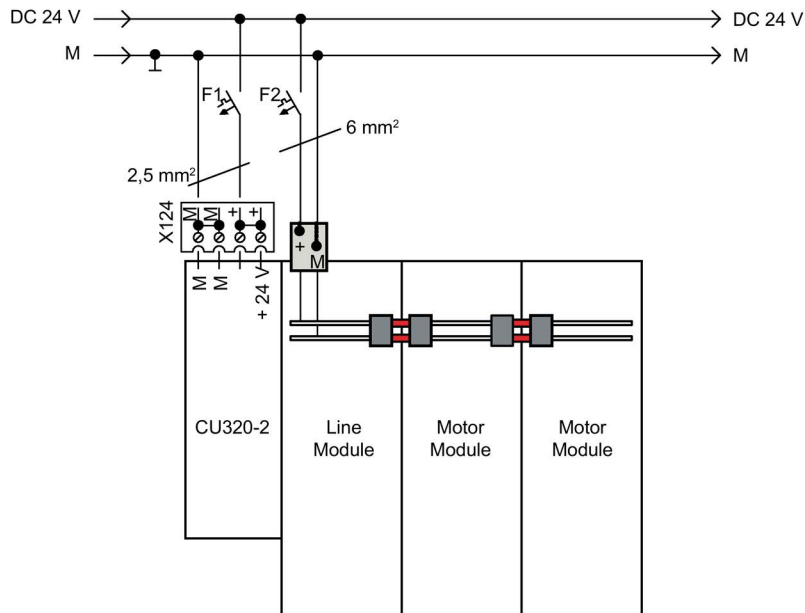

Figure 12-21 Example of a 24 V supply via an external power supply

12.6.3 Overcurrent protection

The cables on the primary and secondary sides of the 24 V power supply unit must be protected against overcurrent.

Primary side protection must be implemented according to the manufacturer's instructions.

Secondary side protection depends on the prevailing situation. Please note the following:

- Loading due to loads, including simultaneity factor depending on machine operation
- Current carrying capacity of the conductors used and cables in normal and short-circuit conditions
- Ambient temperature
- Cable bundling (laying cables in a common duct)
- Type of cable routing

The overcurrent protection devices can be determined according to EN 60204-1, Section 14.

The following are recommended as overload protection devices:

- On the primary side: Circuit breakers
- On the secondary side: Miniature circuit breakers or SITOP select (article number 6EP1961-2BA00)

More detailed specifications can be obtained in the "Siemens Industry Mall (<https://mall.industry.siemens.com/goos/WelcomePage.aspx?regionUrl=/de&language=en>)".

When selecting the miniature circuit breaker, local installation regulations must be carefully complied with.

Table 12- 5 MCBs by conductor cross-section and temperature

Conductor cross-section	Max. value up to 40° C	Max. value up to 55° C
1.5 mm ²	10 A	6 A
2.5 mm ²	16 A	10 A
4 mm ²	25 A	16 A
6 mm ²	32 A	20 A
24 V busbar	20 A	20 A

The trip characteristic of the MCBs must be selected to match the loads to be protected and the max. current provided by the power supply unit in the event of a short-circuit.

12.6.4 Overvoltage protection

Surge arresters are required for cable lengths > 30 m.

The following Weidmüller surge arresters are recommended for protecting the 24 V power supply of the components and the 24 V signal cables against overvoltage:

Table 12- 6 Recommendations for overvoltage protection

24 V power supply	24 V signal cables
Manufacturer: Weidmüller Article: PU III R 24 V Article No.: 8860360000 Alternative: Manufacturer: Weidmüller Article: VPU III R 24 V Article number: 1351580000	Manufacturer: Weidmüller Article: MCZ OVP TAZ Article No.: 844915 0000

The overvoltage protection components must always be placed next to the area to be protected, e.g. at the entry point to the control cabinet. All 24 V cables which exit the protected area must be routed through an overvoltage protection element.

The diagram below uses a CU320-2 DP as an example to show how the overvoltage protection components are connected.

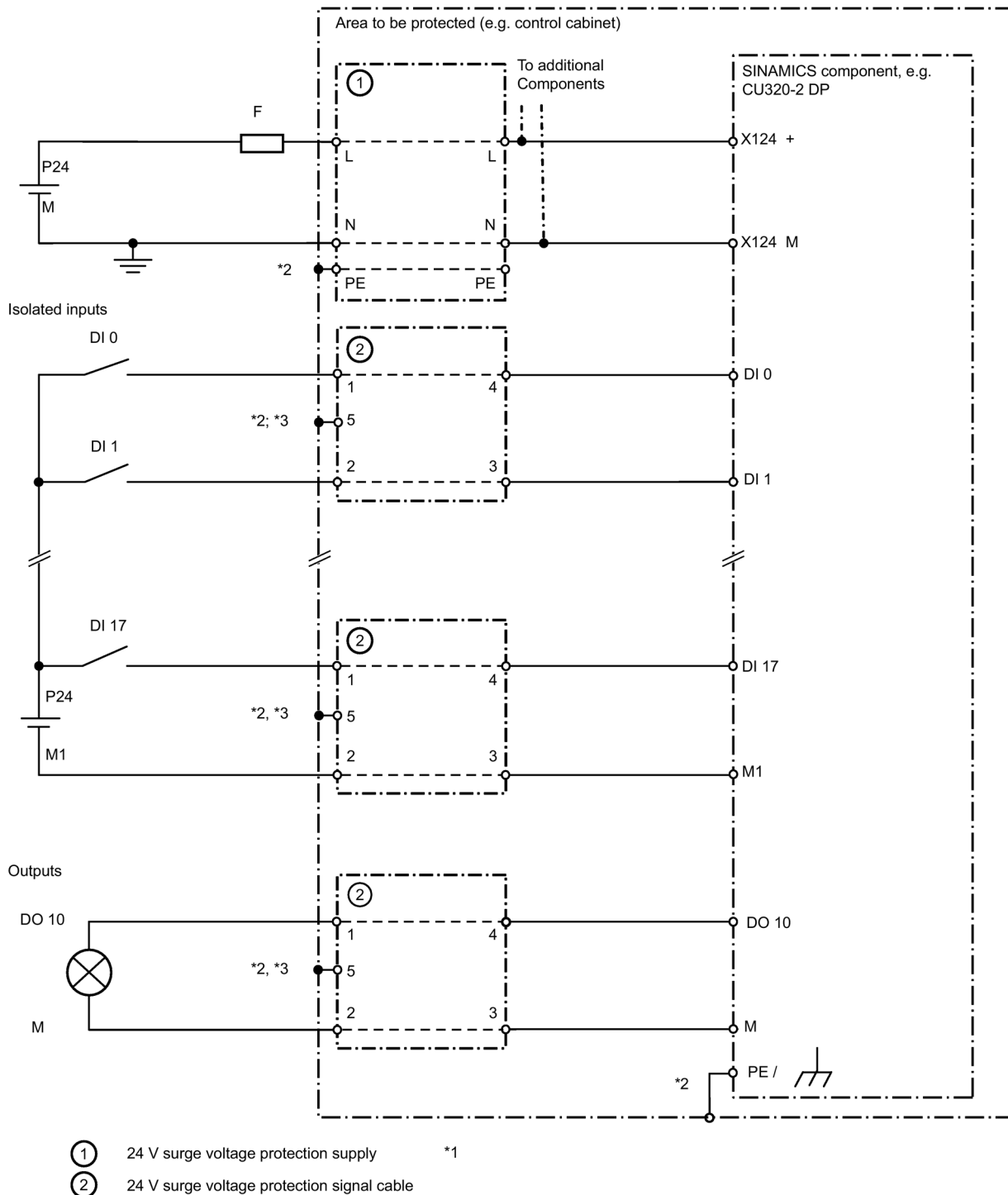

Figure 12-22 Connection example: Surge voltage protection components from Weidmüller connected to SINAMICS components

- *1 For "PU III 24V AC/DC", terminals 11, 12, 14 are electrically isolated monitoring contacts (11 common, 12 NC contact, 14 NO contact). In the case of a thermal overload of the integrated varistor, contact 11-12 is opened and contact 11-14 is closed.
- *2 The metallic enclosure of the SINAMICS components and the PE connection of the surge arrester must be connected with one another to ensure a good electrical connection (equipotential bonding). This can be achieved by installing the SINAMICS components on a metallic mounting plate and connecting the PE connections of the overvoltage protection elements as directly as possible to the mounting plate.
- *3 By snapping the surge arrester (MCZ OVP TAZ) onto a metal mounting rail, the PE connection (terminal 5) is connected to the mounting rail. It is then sufficient to establish a good conductive connection between the DIN rail and the metallic enclosure of the SINAMICS component (equipotential bonding). This is the case when both the DIN rail and the SINAMICS component are mounted on a common metal mounting plate.

12.6.5 Typical 24 V current consumption of the components

A separate 24 V power supply must be used for the SINAMICS S120 drive line-up.

The following table can be used to calculate the 24 V DC power supply for the components. The values for typical current consumption are used as a basis for configuration.

Table 12- 7 Overview of the 24 V DC current consumption

Component	Typical current consumption [A _{DC}]
Control Units	
CU320-2 (without load)	1.00
Per digital output	0.10
Sensor Modules Cabinet	
SMC10 without/with encoder system	0.20 / 0.35
SMC20 without/with encoder system	0.20 / 0.35
SMC30 without/with encoder system	0.20 / 0.55
SMC40 without/with encoder system	0.10 / 0.35
Sensor Modules External	
SME20 without/with encoder system	0.15 / 0.25
SME25 without/with encoder system	0.15 / 0.25
SME120 without/with encoder system	0.20 / 0.30
SME125 without/with encoder system	0.20 / 0.30

Component	Typical current consumption [A _{DC}]
Terminal Modules	
TM15 (without digital outputs, without DRIVE-CLiQ) Per digital output / DRIVE-CLiQ	0.15 0.5
TM31 (without digital outputs, without DRIVE-CLiQ) Sum of all digital outputs Per DRIVE-CLiQ	0.5 0.1/1 (with switchover to current limitation) 0.5
TM41 (without digital outputs, without DRIVE-CLiQ) Per digital output / DRIVE-CLiQ	0.5 0.5
TM54F (without digital outputs, without DRIVE-CLiQ) Per digital output / DRIVE-CLiQ	0.2 0.5
TM120 (without DRIVE-CLiQ) Per DRIVE-CLiQ	0.1 0.5
TM150 (without DRIVE-CLiQ) Per DRIVE-CLiQ	0.07 0.5
Additional system components	
TB30 (without digital outputs) Per digital output	< 0.05 0.1
DMC20 (without DRIVE-CLiQ) Per DRIVE-CLiQ	0.15 0.5
DME20 (without DRIVE-CLiQ) Per DRIVE-CLiQ	0.15 0.5
VSM10 (without DRIVE-CLiQ) DRIVE-CLiQ	0.3 0.5
CBC10	0.1
CBE20	0.1
Active Interface Modules	
16 kW	0.25
36 kW	0.49
55 kW	0.6
80 kW	1.2
120 kW	1.2
Active Line Modules (internal/external air cooling)	
16 kW	0.95
36 kW	1.5
55 kW	1.9
80 kW	1.4
120 kW	1.8

Component	Typical current consumption [A _{DC}]
Active Line Module (cold plate)	
16 kW	0.85
36 kW	1.05
55 kW	1.15
80 kW	1.4
120 kW	1.8
Active Line Module (liquid-cooled)	
120 kW	1.8
Smart Line Modules (internal/external air cooling)	
5 kW	0.8
10 kW	0.9
16 kW	0.95
36 kW	1.5
55 kW	1.9
Smart Line Modules (cold plate)	
5 kW	0.6
10 kW	0.7
Smart Line Modules Booksize Compact	
16 kW (internal air cooling)	0.95
16 kW (cold plate cooling)	0.85
Basic Line Modules (internal/external air cooling)	
20 kW	1.0
40 kW	1.4
100 kW	2.0
Basic Line Modules (cold plate)	
20 kW	0.9
40 kW	1.1
100 kW	1.6
DRIVE-CLiQ and brake	
DRIVE-CLiQ (e.g. motors with DRIVE-CLiQ interface)	0.19
Brake (e.g. motor holding brake)	Typical 0.4 to 1.1; max. 2.0
Single Motor Modules (internal/external air cooling)	
3 A (+1 x DRIVE-CLiQ; +1 x brake)	0.85
5 A (+1 x DRIVE-CLiQ; +1 x brake)	0.85
9 A (+1 x DRIVE-CLiQ; +1 x brake)	0.85
18 A (+1 x DRIVE-CLiQ; +1 x brake)	0.85
30 A (+1 x DRIVE-CLiQ; +1 x brake)	0.80
45 A (+1 x DRIVE-CLiQ; +1 x brake)	1.05
60 A (+1 x DRIVE-CLiQ; +1 x brake)	1.05
85 A (+1 x DRIVE-CLiQ; +1 x brake)	1.50
132 A (+1 x DRIVE-CLiQ; +1 x brake)	0.85
200 A (+1 x DRIVE-CLiQ + 1 x brake)	0.85

Component	Typical current consumption [A _{DC}]
Single Motor Modules (cold plate)	
3 A (+1 x DRIVE-CLiQ; +1 x brake)	0.65
5 A (+1 x DRIVE-CLiQ; +1 x brake)	0.65
9 A (+1 x DRIVE-CLiQ; +1 x brake)	0.65
18 A (+1 x DRIVE-CLiQ; +1 x brake)	0.65
30 A (+1 x DRIVE-CLiQ; +1 x brake)	0.65
45 A (+1 x DRIVE-CLiQ; +1 x brake)	0.75
60 A (+1 x DRIVE-CLiQ; +1 x brake)	0.75
85 A (+1 x DRIVE-CLiQ; +1 x brake)	0.80
132 A (+1 x DRIVE-CLiQ; +1 x brake)	0.85
200 A (+1 x DRIVE-CLiQ; +1 x brake)	0.85
Single Motor Modules (liquid-cooled)	
200 A (+1 x DRIVE-CLiQ; +1 x brake)	0.85
Single Motor Modules Booksize Compact (internal air cooling)	
3 A (+1 x DRIVE-CLiQ; +1 x brake)	0.85
5 A (+1 x DRIVE-CLiQ; +1 x brake)	0.85
9 A (+1 x DRIVE-CLiQ; +1 x brake)	0.85
18 A (+1 x DRIVE-CLiQ; +1 x brake)	0.85
Single Motor Modules Booksize Compact (cold plate)	
3 A (+1 x DRIVE-CLiQ; +1 x brake)	0.65
5 A (+1 x DRIVE-CLiQ; +1 x brake)	0.65
9 A (+1 x DRIVE-CLiQ; +1 x brake)	0.65
18 A (+1 x DRIVE-CLiQ; +1 x brake)	0.65
Double Motor Modules (internal and external air cooling)	
2 x 3 A (+2 x DRIVE-CLiQ; +2 x brake)	1.15
2 x 5 A (+2 x DRIVE-CLiQ; +2 x brake)	1.15
2 x 9 A (+2 x DRIVE-CLiQ; +2 x brake)	1.15
2 x 18 A (+2 x DRIVE-CLiQ; +2 x brake)	1.30
Double Motor Modules (cold plate)	
2 x 3 A (+2 x DRIVE-CLiQ; +2 x brake)	1.00
2 x 5 A (+2 x DRIVE-CLiQ; +2 x brake)	1.00
2 x 9 A (+2 x DRIVE-CLiQ; +2 x brake)	1.00
2 x 18 A (+2 x DRIVE-CLiQ; +2 x brake)	1.15
Double Motor Modules Booksize Compact (internal air cooling)	
2 x 1.7 A (+2 x DRIVE-CLiQ; +2 x brake)	1.15
2 x 3 A (+2 x DRIVE-CLiQ; +2 x brake)	1.15
2 x 5 A (+2 x DRIVE-CLiQ; +2 x brake)	1.15
Double Motor Modules Booksize Compact (cold plate)	
2 x 1.7 A (+2 x DRIVE-CLiQ; +2 x brake)	0.90
2 x 3 A (+2 x DRIVE-CLiQ; +2 x brake)	0.90
2 x 5 A (+2 x DRIVE-CLiQ; +2 x brake)	0.90

Component	Typical current consumption [A _{DC}]
Braking Module Booksize	0.50
Braking Module Booksize Compact	0.40

If not specified otherwise, the listed Line Modules and Motor Modules are Booksize components.

Example: Calculating the 24 V current requirement

Table 12- 8 Example of 24 V current requirements

Component	Quantity	Current consumption [A]	Total current consumption [A]
CU320-2	1	1.0	1.0
8 digital outputs	8	0.1	0.8
Active Line Module 36 kW	1	1.5	1.5
Motor Module 18 A	2	0.85	1.7
Motor Module 30 A	3	0.8	2.4
Encoders	5	0.25	1.25
Brake	5	1.1	5.5
Total:			14.15

12.6.6 Selecting power supply units

You are advised to use the devices in the following table. These devices meet the applicable requirements of EN 60204-1.

Table 12- 9 Recommended SITOP Power

Rated output current [A]	Phases	Rated input voltage [V] Operating voltage range [V]	Short-circuit current [A]	Article No.
5	1 / 2	AC 120 ... 230/230 ... 500 85 ... 264/176 ... 550	Approx. 5.5 (powering up) Typ. 15 for 25 ms (in operation)	6EP1333-3BA00-8AC0
10	1 / 2	AC 120 ... 230/230 ... 500 85 ... 264/176 ... 550	Approx. 12 (powering up) Typ. 30 for 25 ms (in operation)	6EP1334-3BA00-8AB0
20	1 / 2	AC 120 / 230 85 ... 132/176 ... 264	Approx. 23 (powering up) Typ. 60 for 25 ms (in operation)	6EP1336-3BA00-8AA0
	3	3 AC 230/400 ... 288/500 320 ... 550		6EP1436-3BA00-8AA0
40	1 / 2	AC 120/230 85 ... 132/176 ... 264	Approx. 46 (powering up) Typ. 120 for 25 ms (in operation)	6EP1337-3BA00-8AA0
	3	3 AC 230/400 ... 288/500 320 ... 550		6EP1437-3BA00-8AA0

Table 12- 10 Recommendation for Control Supply Module

Rated output current [A]	Phases	Input voltage range [V]	Short-circuit current [A]	Article No.
20	3	3-phase 380 V AC -10 % (-15 % < 1 min) to 480 V AC +10% DC 300 ... 800	< 24	6SL3100-1DE22-0AA.



⚠ WARNING
<p>Hazardous voltage when connecting an unsuitable power supply</p> <p>If a power supply is connected that is not suitable, parts and components of the device could be live (under voltage). Touching live components can result in death or severe injury.</p> <ul style="list-style-type: none"> • Connect the ground potential to the PE conductor connection. • Mount the power supply close to the drive lineup. <p>Ideally, they should be mounted on a common mounting plate. If different mounting plates are used, they must be electrically connected in compliance with the Configuration Manual, "EMC installation guideline".</p>

12.7 Connection systems

Note

Conditions for UL applications

- Only use copper cables rated for 60 °C or 75 °C.
- Wherever ring cable lugs are used for the connection of line and motor, only use UL-listed ring cable lugs (ZMVV) that are approved for the respective voltage. The permissible current must be at least 125% of the input or output current. Use the higher value as basis.

12.7.1 DRIVE-CLiQ signal cables

12.7.1.1 Overview

To connect DRIVE-CLiQ components, various pre-assembled and non-assembled DRIVE-CLiQ signal cables are available. The following pre-assembled DRIVE-CLiQ signal cables will be discussed in more detail in the next sections:

- Signal cables without 24 V cores with RJ45 connectors
- MOTION-CONNECT signal cables with DRIVE-CLiQ connectors
- MOTION-CONNECT signal cables with DRIVE-CLiQ connector and M12 socket

Table 12- 11 Overview of pre-assembled DRIVE-CLiQ signal cables

Type of DRIVE-CLiQ signal cable	24 V cores	Degree of protection		Connector type
		IP20	IP67	
6SL3060-4A.. 6FX2002-1DC..	--	x	x	RJ45
6FX5002-2DC00.. to .. -2DC20.. 6FX8002-2DC00.. to .. -2DC20..	x	x	x	DRIVE-CLiQ
6FX5002-2DC30.. 6FX8002-2DC30..	x	X (DRIVE-CLiQ)	X (M12)	DRIVE-CLiQ / M12

12.7.1.2 DRIVE-CLiQ signal cables without 24 V DC cores

Pre-assembled DRIVE-CLiQ signal cables without 24 V DC cores are used to connect components with DRIVE-CLiQ connection, which have a separate or external 24 V DC power supply. They are mainly intended for use in control cabinets. The signal cables are available with RJ45 connectors in degrees of protection IP20 and IP67.

Table 12- 12 Actual lengths of the DRIVE-CLiQ jumpers for Line Modules and Motor Modules

DRIVE-CLiQ bridge	Cable length L ¹⁾
50 mm	110 mm
100 mm	160 mm
150 mm	210 mm
200 mm	260 mm
250 mm	310 mm
300 mm	360 mm
350 mm	410 mm

1) Cable length without connector

Cable lengths from 600 mm and higher are used to connect to other applications (e.g. establish a 2nd line in the drive line-up, establish wiring in a star configuration etc.)

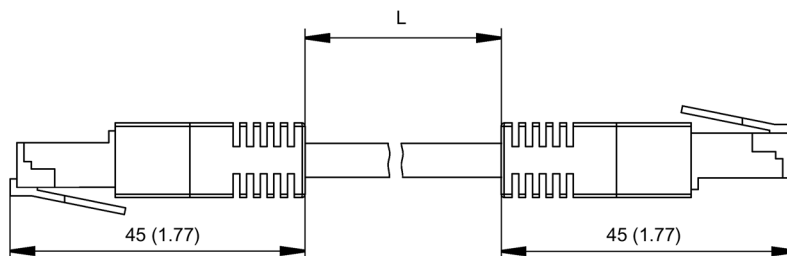

Figure 12-23 DRIVE-CLiQ signal cables without 24 V DC cores (IP20)

12.7.1.3 DRIVE-CLiQ signal cables MOTION-CONNECT with RJ45 connectors

The MOTION-CONNECT DRIVE-CLiQ signal cables with RJ45 plugs have 24 V cores. They are used for components with DRIVE-CLiQ connection if higher requirements must be complied with, such as mechanical stress and resistance to oil. For example, the signal cables are used for connections outside the control cabinet:

- Connections between Motor Modules and Sensor Modules
- Connections between Motor Modules and motors with DRIVE-CLiQ interface

The maximum length of the DRIVE-CLiQ MOTION-CONNECT signal cables with RJ45 plugs is:

- 100 m for MOTION-CONNECT 500 cables
- 75 m for MOTION-CONNECT 800PLUS cables

The signal cables are available in degrees of protection IP20 and IP67.

Note**DRIVE-CLiQ cabinet bushing for RJ45 connectors**

For information on the cabinet bushings, see Chapter DRIVE-CLiQ cabinet bushings (Page 631).

12.7.1.4 DRIVE-CLiQ signal cables MOTION-CONNECT with RJ45 plug and M12 socket

The MOTION-CONNECT DRIVE-CLiQ signal cables with RJ45 plug and M12 socket have 24 VDC cores. They establish the connection between components with a DRIVE-CLiQ connection and a direct measuring system equipped with DRIVE-CLiQ ASIC with 8-pin M12 connector. Measuring systems from third-party manufacturers can be directly connected to the SINAMICS S120.

Basic cable

The pre-assembled basic cable has eight cores, of which four are used for data transmission and two for the 24 V supply. It is used to convert from a RJ45 plug (IP20) to an M12 socket (IP67).

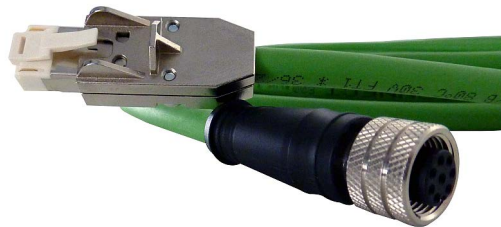

Figure 12-24 DRIVE-CLiQ basic cable with RJ45 plug and M12 socket

Extension

The pre-assembled extension of a basic cable has an M12 plug (IP67) and an M12 socket (IP67).



Figure 12-25 DRIVE-CLiQ extension with M12 plug and M12 socket

Note

Maximum permissible total cable length

The maximum permissible total cable length between the measuring system and the RJ45 socket of the SINAMICS S120 device is 30 m. For a longer total cable length data transfer errors may occur. This is the reason that no additional extension can be connected to a 30 m long basic cable.

Note

Maximum number of extensions

A maximum of two extensions can be used. More than two extensions can result in data transfer errors.

Note

DRIVE-CLiQ cabinet bushing with M12 plug

For information on the cabinet bushings, see Section "DRIVE-CLiQ cabinet bushings (Page 631)".

12.7.1.5 Comparison of DRIVE-CLiQ signal cables

DRIVE-CLiQ signal cables are designed for various applications. The following table provides an overview of the most important properties.

Table 12- 13 Properties of DRIVE-CLiQ signal cables

DRIVE-CLiQ signal cable	DRIVE-CLiQ	DRIVE-CLiQ MOTION-CONNECT 500	DRIVE-CLiQ MOTION-CONNECT 800PLUS
Approvals			
cURus or UR/CSA ¹⁾	Yes	Yes	Yes
In conformance with RoHS	Yes	Yes	Yes
Rated voltage V_0/V in accordance with EN 50395	30 V	30 V	30 V
Test voltage, rms	500 V	500 V	500 V
Operating temperature at the surface			
Permanently installed	-20 ... +80 °C	-20 ... +80 °C	-20 ... +80 °C
Moveable	-	0 ... 60 °C	-20 ... +60 °C
Tensile load, max.			
Permanently installed	45 N/mm ²	80 N/mm ²	50 N/mm ²
Moveable	-	30 N/mm ²	20 N/mm ²
Smallest bending radius			
Permanently installed	25 mm	35 mm	35 mm
Moveable	-	125 mm	75 mm
Torsional stress	-	30 °/m absolute	30 °/m absolute
Bending operations	-	100000	10 million
Max. travel velocity	-	30 m/min	300 m/min
Max. acceleration	-	2 m/s ²	50 m/s ² (3 m distance moved through) ²⁾
insulation material	CFC/silicon-free	CFC/silicon-free	CFC/halogen/silicone-free IEC 60754-1 / DIN VDE 0472-815
Oil resistance	EN 60811-2-1	EN 60811-2-1 (mineral oil only)	EN 60811-2-1
Protective jacket	PVC Gray RAL 7032	PVC DESINA color green RAL 6018	PUR, HD22.10 S2 (VDE 0282, Part 10) DESINA color green, RAL 6018
Flame retardant	EN 60332-1-1 to 1-3	EN 60332-1-1 to 1-3	EN 60332-1-1 to 1-3

1) The UR/CSA file number is stamped on the cable sheath.

2) Acceleration characteristics, refer below

Characteristics for MOTION-CONNECT 800PLUS

The cables can be used in the area below the characteristic. The characteristics represent the tested operating points.

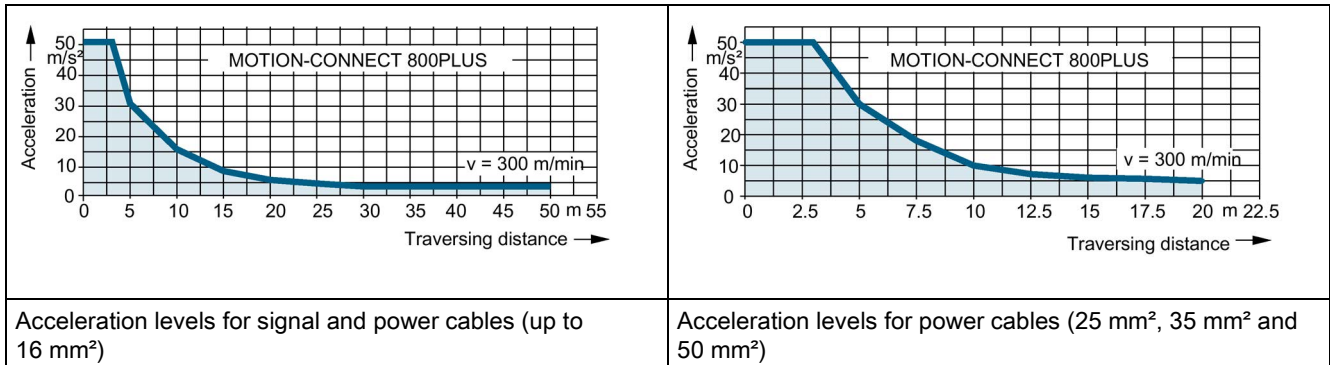

12.7.1.6 Connecting a direct measuring system

The various options of connecting a direct measuring system with DRIVE-CLiQ ASIC and M12 plug via MOTION-CONNECT cables to a DRIVE-CLiQ component are shown in the following diagram.

1. Direct connection via the basic cable
2. Basic cable and 1-2 extensions
3. Basic cable, cabinet bushing and a maximum of one extension

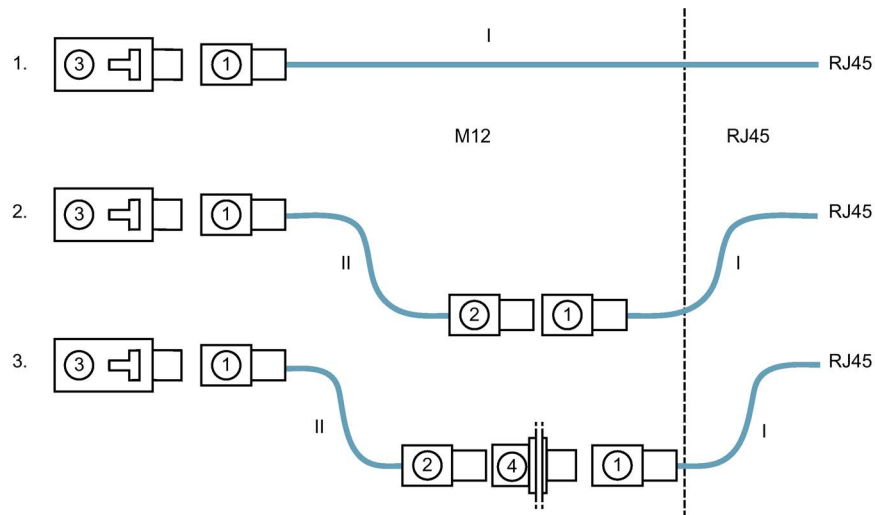

- ① M12 socket (IP67) connected to a MOTION-CONNECT DRIVE-CLiQ signal cable
- ② M12 plug (IP67) connected to a MOTION-CONNECT DRIVE-CLiQ signal cable
- ③ M12 plug (IP67) connected to a third-party measuring system
- ④ DRIVE-CLiQ cabinet bushing M12
- I Basic cable
- II Extension

Figure 12-26 Connecting a direct measuring system with M12 plug to a DRIVE-CLiQ component with RJ45 socket (IP20)

12.7.1.7 Combined use of MOTION-CONNECT 500 and MOTION-CONNECT 800PLUS

In principle, MOTION-CONNECT 500 cables and MOTION-CONNECT 800PLUS cables be used together.

Basic cables and extensions for MOTION-CONNECT cables with DRIVE-CLiQ connector and M12 socket can be combined without any restrictions.

For the combined use of MOTION-CONNECT cables with DRIVE-CLiQ connectors, the conditions below apply.

Use of DRIVE-CLiQ couplings

DRIVE-CLiQ couplings are used to combine MOTION-CONNECT 500 cables and MOTION-CONNECT 800PLUS cables with DRIVE-CLiQ connectors. The maximum permissible cable length is calculated as follows:

$$\Sigma MC500 + 4/3 * \Sigma MC800PLUS + n_c * 5 \text{ m} \leq 100 \text{ m}$$

$\Sigma MC500$: Total length of all MC500 cable segments (fixed routing)

$\Sigma MC800PLUS$: Total length of all MC800PLUS cable segments (tow chain)

n_c : Number of DRIVE-CLiQ couplings (0 to max. of 3)

With this combination, DRIVE-CLiQ cables with a maximum length of over 75 m can also implemented for applications involving a tow chain.

Table 12- 14 Examples of maximum cable lengths when using a DRIVE-CLiQ coupling

$\Sigma MC500$ (fixed routing)	87 m	80 m	66 m	54 m	40 m	30 m	20 m	10 m	5 m
$\Sigma MC800PLUS$ (tow chain)	5 m	10 m	20 m	30 m	40 m	48 m	55 m	63 m	66 m
$\Sigma MC500+$ $\Sigma MC800PLUS$	92 m	90 m	86 m	84 m	80 m	78 m	75 m	73 m	71 m

Using a DRIVE CLiQ Hub Module

A DRIVE-CLiQ Hub Module (DMC20 or DME20) can be used to double the maximum permissible cable length for MOTION-CONNECT cables with DRIVE-CLiQ connectors. After the hub, the same length conditions apply as before the hub.

$$\Sigma MC500 + 4/3 * \Sigma MC800PLUS + n_c * 5 \text{ m} \leq 100 \text{ m before the hub}$$

$$\Sigma MC500 + 4/3 * \Sigma MC800PLUS + n_c * 5 \text{ m} \leq 100 \text{ m after the hub}$$

It is possible to connect two DRIVE-CLiQ Hub Modules in series (cascade connection).

12.7.2 Power cables for motors

12.7.2.1 Configuring the cable length

Where a longer motor cable is required, a higher rating Motor Module must be selected, or the permissible continuous output current $I_{\text{continuous}}$ must be reduced in relation to the rated output current I_{rated} . The configuring data for booksize format Motor Modules are given in the following table:

Table 12- 15 Permissible cable lengths for shielded motor cables

Motor Module	Length of motor cable (shielded)			
	> 50 ... 100 m	> 100 ... 150 m	> 150 ... 200 m	> 200 m
Rated output current I_N				
3 A/5 A	Use 9 A Motor Module	Use 9 A Motor Module	Not permissible	Not permissible
9 A	Use 18 A Motor Module	Use 18 A Motor Module	Not permissible	Not permissible
18 A	Use 30 A Motor Module or $I_{\text{max}} \leq 1.5 \times I_{\text{rated}}$ $I_{\text{continuous}} \leq 0.95 \times I_{\text{rated}}$	Use 30 A Motor Module	Not permissible	Not permissible
30 A	Always permitted	$I_{\text{max}} \leq 1.35 \times I_{\text{rated}}$ $I_{\text{continuous}} \leq 0.9 \times I_{\text{rated}}$	$I_{\text{max}} \leq 1.1 \times I_{\text{rated}}$ $I_{\text{continuous}} \leq 0.85 \times I_{\text{rated}}$	Not permissible
45 A/60 A	Always permitted	$I_{\text{max}} \leq 1.75 \times I_{\text{rated}}$ $I_{\text{continuous}} \leq 0.9 \times I_{\text{rated}}$	$I_{\text{max}} \leq 1.5 \times I_{\text{rated}}$ $I_{\text{continuous}} \leq 0.85 \times I_{\text{rated}}$	Not permissible
85 A/132 A	Always permitted	$I_{\text{max}} \leq 1.35 \times I_{\text{rated}}$ $I_{\text{continuous}} \leq 0.95 \times I_{\text{rated}}$	$I_{\text{max}} \leq 1.1 \times I_{\text{rated}}$ $I_{\text{continuous}} \leq 0.9 \times I_{\text{rated}}$	Not permissible
200 A	Always permitted	$I_{\text{max}} \leq 1.25 \times I_{\text{rated}}$ $I_{\text{continuous}} \leq 0.95 \times I_{\text{rated}}$	$I_{\text{max}} \leq 1.1 \times I_{\text{rated}}$ $I_{\text{continuous}} \leq 0.9 \times I_{\text{rated}}$	Not permissible

When using a motor holding brake, the maximum motor cable length is 100 m.

The permissible cable length for an unshielded motor cable is 150 % of the length for a shielded motor cable.

Motor reactors can also be used on motors operating in vector and V/f control modes to allow the use of longer motor cables.

12.7.2.2 Comparison of MOTION-CONNECT power cables

MOTION-CONNECT 500 power cables are mainly suitable for permanent routing. MOTION-CONNECT 800PLUS power cables fulfill all of the high mechanical requirements for use in tow chains. They are resistant to cutting oils.

Table 12- 16 Comparison of the MOTION-CONNECT 500 and MOTION-CONNECT 800PLUS power cables

Power cable	MOTION-CONNECT 500	MOTION-CONNECT 800PLUS
Approvals		
VDE ¹⁾	Yes	Yes
cURus or UR/CSA ²⁾	Yes	Yes
In conformance with RoHS	Yes	Yes
Rated voltage V_0/V in accordance with EN 50395		
Supply conductors	600 V / 1000 V	600 V / 1000 V
Signal conductors	24 V (EN) 1000 V (UL/CSA)	24 V (EN) 1000 V (UL/CSA)
Test voltage, rms		
Supply conductors	4 kV	4 kV
Signal conductors	2 kV	2 kV
Operating temperature at the surface		
Permanently installed	-20 ... +80 °C	-50 ... +80 °C
Moveable	0 ... 60 °C	-20 ... +60 °C
Tensile load, max.		
Permanently installed	50 N/mm ²	50 N/mm ²
Moveable	20 N/mm ²	20 N/mm ²
Smallest bending radius		
Permanently installed	5 x D _{max}	4 x D _{max}
Moveable	approx. 18 x D _{max}	approx. 8 x D _{max}
Torsional stress		
	30 °/m absolute	30 °/m absolute
Bending operations		
	100000	10 million
Max. traversing velocity		
	30 m/min	Up to 300 m/min
Max. acceleration		
	2 m/s ²	50 m/s ² (3 m) ³⁾
insulation material		
	CFC/silicon-free	CFC/halogen/silicon-free IEC 60754-1 / DIN VDE 0472-815
Oil resistance		
	EN 60811-2-1 (mineral oil only)	EN 60811-2-1
Protective jacket		
	PVC DESINA color, orange RAL 2003	PUR, HD22.10 S2 (VDE 0282, Part 10) DESINA color, orange, RAL 2003
Flame retardant		
	EN 60332-1-1 to 1-3	EN 60332-1-1 to 1-3

1) The registration number is printed on the cable jacket.

2) The UR/CSA file number is stamped on the cable sheath.

3) Characteristic curves for accelerating can be found in Catalog "PM21" in Chapter "MOTION-CONNECT connection system."

12.7.3 Current-carrying capacity and derating factors for power cables and signal cables

The current carrying capacity of PVC/PUR-insulated copper cables is specified for routing types B1, B2 and C under continuous operating conditions in the table below with reference to an ambient air temperature of 40° C. For other ambient temperatures, the values must be corrected by the factors listed in the "Derating factors for deviating ambient temperatures" table.

Table 12- 17 Routing types

B1	Cables in conduits or cable ducts
B2	Multi-conductor cables in conduits or cable ducts
C	Cables along walls, without conduits or cable ducts

Table 12- 18 Current carrying capacity according to EN 60204-1 for 40° C ambient temperature

Cross-section mm ²	Current carrying capacity, effective; AC 50/60 Hz or DC For routing type		
	B1 A	B2 A	C A
Signal cables			
0.20	–	4.3	4.4
0.50	–	7.5	7.5
0.75	–	9	9.5
Power cables			
0.75	8.6	8.5	9.8
1.00	10.3	10.1	11.7
1.50	13.5	13.1	15.2
2.50	18.3	17.4	21
4	24	23	28
6	31	30	36
10	44	40	50
16	59	54	66
25	77	70	84
35	96	86	104
50	117	103	125
70	149	130	160
95	180	165	194
120	208	179	225

Table 12- 19 Current carrying capacity according to IEC 60364-5-52 for 40° C ambient temperature

Cross-section mm ²	Current carrying capacity, effective; AC 50/60 Hz or DC For routing type		
	B1 A	B2 A	C A
Power cables			
150	–	–	260
185	–	–	297
> 185	Values must be taken from the standard		

Table 12- 20 Derating factors for deviating ambient temperatures

Ambient air temperature [° C]	Derating factor according to EN 60204-1, Table D1
30	1.15
35	1.08
40	1.00
45	0.91
50	0.82
55	0.71
60	0.58

12.7.4 Maximum cable lengths

The table below provides an overview of the maximum permissible cable lengths for signal and supply cables, power cables, and DC link cables.

Note

Total cable lengths for Line Modules

For data regarding maximum total cable lengths of Line Modules and general conditions for maintaining the corresponding radio interference suppression category, see Chapter Combination options of Line Modules with line reactors and line filters (Page 120).

Table 12- 21 Maximum cable lengths

Type	Maximum length [m]
24 V DC power supply cables	30 ¹⁾
24 V signal cables	30 ¹⁾
DRIVE-CLiQ signal cables MC500 (RJ45)	100
DRIVE-CLiQ signal cables MC500 (M12)	30
DRIVE-CLiQ signal cables MC800PLUS (RJ45)	75
DRIVE-CLiQ signal cables MC800PLUS (M12)	30
DC link, including extensions	10
Power cable between line filter and line reactor	10 (shielded/unshielded) ²⁾
Power cable between line reactor and Line Module	10 (shielded/unshielded) ²⁾
Power cable between motor and Motor Module up to $I_n = 9 \text{ A}$	50 (shielded) 75 (unshielded)
Power cable between motor and Motor Module $I_n = 18 \text{ A}$	70 (shielded) 100 (unshielded)
Power cable between motor and Motor Module $I_n \geq 30 \text{ A}$	100 (shielded) 150 (unshielded)
Power cable between Braking Module and braking resistor	10

1) For longer lengths, users must connect suitable protective circuitry in order to provide surge voltage protection (refer to Chapter "24 V DC supply/surge voltage protection").

2) To comply with EMC limit values, shielded cables (preferably MOTION-CONNECT cables) must be used.

12.7.5 Connectable conductor cross-sections and tightening torques for motor and power cables

Table 12- 22 Connectable conductor cross-sections Part 1: Line cable/motor cable

Component	Terminal type/tightening torque	Connection cross-section [mm ²]						
		1.5	2.5	4	6	10	16	
Motor Module Booksize 3 ... 30 A 2 x 3 A ... 2 x 18 A	Motor connection connector	Crimped con- nector	X	X	X	X	X	-
	30 A, 3+2 pole		Screw con- nector	X	X	X	X	-
Motor Module Booksize Compact 1.7 A ... 18 A	Screw terminal 1.2 ... 1.5 Nm (10.6 ... 13.3 lbf in)			X	X	X	X	-
Motor Module 45 ... 60 A	Threaded bolt M6 6 Nm (53.1 lbf in) ¹⁾		-	-	-	X	X	X
Motor Module 85 A	Threaded bolt M8 13 Nm (115 lbf in) ²⁾		-	-	-	-	-	X
Smart Line Module Booksize 5 ... 10 kW	Screw terminal 1.2 ... 1.5 Nm (10.6 ... 13.3 lbf in)		X	X	X	X	-	-
Smart Line Module Booksize Compact 16 kW	Screw terminal 1.5 ... 1.8 Nm (13.3 ... 15.9 lbf in)		-	-	-	X	X	X
Active Line Module 16 kW Smart Line Module 16 kW	Screw terminal 1.5 ... 1.8 Nm (13.3 ... 15.9 lbf in)		-	-	-	X	X	-
Active Line Module 36 kW Smart Line Module 36 kW	Threaded bolt M6 6 Nm (53.1 lbf in) ¹⁾		-	-	-	-	-	X
Active Interface Module 16 kW	Screw terminal 1.7 Nm (15.0 lbf in)		-	-	-	X	X	X
Active Interface Module 36 kW	Screw terminal 6 Nm (53.1 lbf in)		-	-	-	-	-	X

- 1) For ring cable lugs without insulation clamping area ensured for flexible cable with end sleeve, ring cable lug M6 or M8 IP2xB according to IEC 60529;
Note: The restrictor collar installed as standard for the purpose of touch protection must be used or adapted as required.
- 2) Alternatively, two ring cable lugs without insulation for the parallel connection of 2 cables with a maximum cross-section of 50 mm² can also be connected to the threaded bolts respectively. Both cable lugs should be mounted "back to back".

Note

Compliance with IPXXB degree of protection for Active Interface Modules 36 kW

The connection terminals of the 36 kW Active Interface Module are only certain to have degree of protection IPXXB according to IEC 60529, if cables with a minimum cross-section of 25 mm² and insulated end sleeves are used.

12.7 Connection systems

Table 12- 23 Connectable conductor cross-sections Part 2: Line cable/motor cable

Component	Terminal type/tightening torque	Connection cross-section [mm ²]					
		25	35	50	70	95	120
Motor Module 45 ... 60 A	Threaded bolt M6 6 Nm (53.1 lbf in) ¹⁾	X	X	X	-	-	-
Motor Module 85 A	Threaded bolt M8 13 Nm (115 lbf in) ²⁾	X	X	X	X	X	X
Motor Module 132 ... 200 A	Threaded bolt M8 13 Nm (115 lbf in) ²⁾	X	X	X	X	X	X
Active Line Module 36 kW Smart Line Module 36 kW	Threaded bolt M6 6 Nm (53.1 lbf in)	X	X	X	-	-	-
Active Line Module 55 kW Smart Line Module 55 kW	Threaded bolt M8 13 Nm (115 lbf in) ²⁾	-	X	X	X	X	X
Active Line Module 80 ... 120 kW	Threaded bolt M8 13 Nm (115 lbf in) ²⁾	-	-	-	X	X	X
Active Interface Module 36 kW	Screw terminal 6 Nm (53.1 lbf in)	X	X	X	-	-	-
Active Interface Module 55 kW	Screw terminal 6 Nm (53.1 lbf in)	-	X	X	-	-	-
Active Interface Module 80 ... 120 kW	Threaded bolt M8 13 Nm (115 lbf in) ²⁾	-	-	-	X	X	X

- 1) For ring cable lugs without insulation clamping area ensured for flexible cable with end sleeve, ring cable lug M6 or M8 IP2xB according to IEC 60529;
Note: The restrictor collar installed as standard for the purpose of touch protection must be used or adapted as required.
- 2) Alternatively, two ring cable lugs without insulation for the parallel connection of 2 cables with a maximum cross-section of 50 mm² can also be connected to the threaded bolts respectively. Both cable lugs should be mounted "back to back".

Table 12- 24 Connectable conductor cross-sections Part 3: Line cable/connection for braking resistor

Component	Terminal type/tightening torque	Connection cross-section [mm ²]					
		1.5	2.5	4	6	10	16
Basic Line Module 20 kW Line cable connection	Screw terminal 1.5 ... 1.7 Nm (13.3 ... 15.0 lbf in)	-	-	-	x	x	x
Basic Line Module 20 kW Braking resistor connection	Screw terminal 0.5 ... 0.6 Nm (4.4 ... 5.3 lbf in)	x	x	x	-	-	-
Basic Line Module 40 kW Braking resistor connection	Screw terminal 1.5 ... 1.8 Nm (13.3 ... 15.9 lbf in)	-	-	x	x	x	-

Table 12- 25 Connectable conductor cross-sections Part 4: Line supply cable

Component	Terminal type/tightening torque	Connection cross-section [mm ²]					
		25	35	50	70	95	120
Basic Line Module 40 kW Line cable connection	Screw terminal 6 Nm (53.1 lbf in)	x	x	x	-	-	-
Basic Line Module 100 kW Line cable connection ¹⁾	Threaded bolt M8 13 Nm (115 lbf in)	-	-	-	x	x	x

¹⁾ Alternatively, two ring cable lugs without insulation for the parallel connection of 2 cables with a maximum cross-section of 50 mm² can also be connected to the threaded bolts respectively. Both cable lugs should be mounted "back to back".

 WARNING
Overheating of power cables when permissible cross-sections are fallen below
Excessively thin power cables can result in overheating. This can result in severe injury or death due to fire and smoke.
<ul style="list-style-type: none"> • Only use power cables with sufficiently large cross-sections. Take into account the routing type, ambient temperature and cable length. • If smaller cross-sections are selected, you must ensure the appropriate level of conductor protection in another way, e.g. by suitably setting the control parameters.

Note

Compliance with IPXXB degree of protection for Basic Line Modules 40 kW

Degree of protection IPXXB according to IEC 60529 for the Basic Line Module 40 kW is only obtained when power cables with insulated end sleeves and cross-sections > 25 mm² are used.

Note

Selection of the line supply conductor

When selecting the line supply conductor, note the loop resistance so that the relevant protective components (line fuse, RCCB, etc.) function properly and that no hazardous shock currents or voltages occur in the event of a fault.

If the apparent impedance of the line supply at the infeed point is not suitable, so that fuses do not rupture in the specified time in the case of insulation failure (ground fault, fault to frame), then you must use additional fault current protective devices RCD (RCCB or MRCD), Type B to protect personnel and protect against fire.

12.7.6 Motor connection connector

Motor Modules 3 A to 30 A are supplied without a motor plug connector (power connector). Prefabricated MOTION-CONNECT power cables with pre-assembled motor connectors or unassembled power cables can be used to connect motors.

The motor plug connector must be ordered separately for power cables that do not have preassembled connectors (screw connector with article number 6SL3162-2MA00-0AA0).

The motor connector is equipped with a locking mechanism. Mounting on the Motor Module is described in the following.

12.7.6.1 Mounting on the Motor Module

Motor connectors with locking mechanism are available in two versions:

- Crimp plug for pre-assembled motor cables
- Screw connector for motor cables that need to be assembled

The way in which motor connectors are installed depends on the type of Motor Module used.

Note

With Double Motor Modules, the rear motor connector must be installed first and then locked.

Installation on Motor Modules without pre-assembled interlock bolt

Figure 12-27 Installation example: Crimp plug

1. Screw the interlocking bolts into the thread provided in the housing.
2. Insert the connector, including the motor cable, and lock it in place using a screwdriver or size 4 hexagon socket-head screw clockwise by turning a $\frac{1}{4}$ turn (90°).

Installation on Motor Modules with pre-assembled interlock bolt

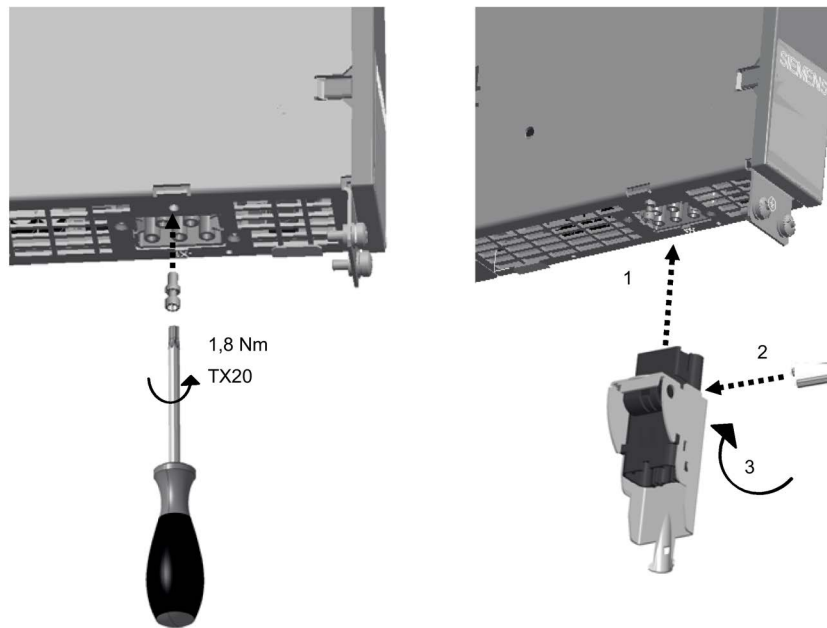
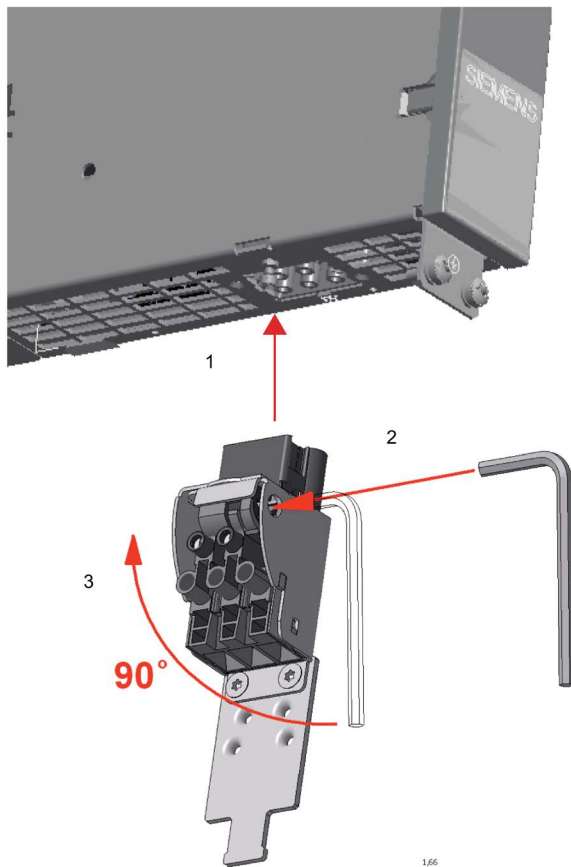

Figure 12-28 Installation example: Screw connector

Insert the connector, including the motor cable, and lock it in place using a screwdriver or size 4 hexagon socket-head screw clockwise by turning a ¼ turn (90°).

12.7.6.2 Attaching the motor connector to self-fabricated cables

Preparing the power cable

Non-assembled power cables must be appropriately prepared before the motor connector is connected.

1. Remove the cable sheath to $200 \text{ mm} \pm 5 \text{ mm}$.
2. Fix the braided shield, e.g. with heat-shrink tubing
3. Remove the insulation from the individual U, V, W conductors and the motor holding brake connecting cables and shorten these corresponding to the drawing shown below.
4. Remove the insulation from the single PE conductor, and crimp this with a ring cable lug without insulation (Page 710).

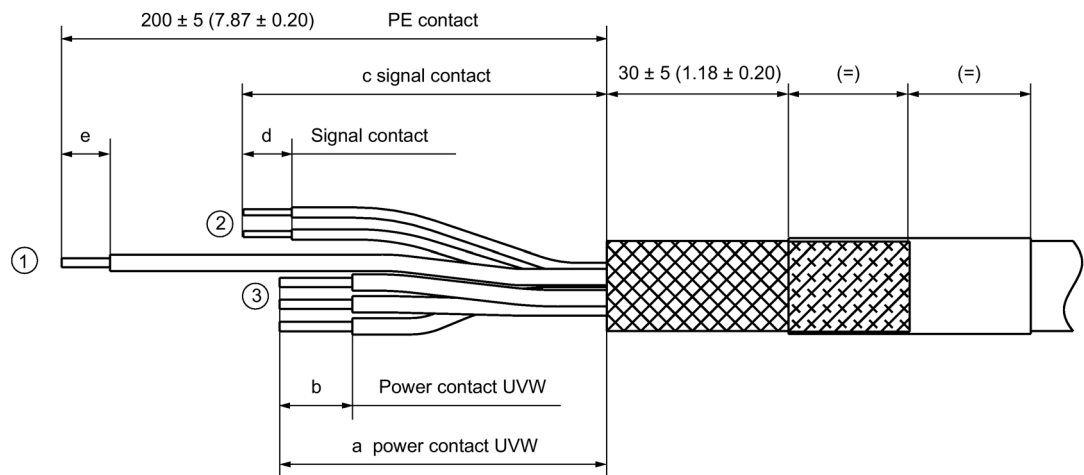

- ① Crimped with ring cable lugs without insulation
- ② Crimped with conductor end sleeves according to DIN 46228-A1.5-10
- ③ Crimped with conductor end sleeves according to DIN 46228-E(1.5...10)-12
- a, b, c, d Lengths depend on mounting a shield connection plate (see below)
- e Length is dependent on the cable cross-section (see ring cable lug (Page 710))

Figure 12-29 Recommended stripped cable lengths for self-fabricated motor power cables, all data in mm and (inches)

Shield support

The following options are available for cable shield support:

- Shield support with shield plate supplied
- Shield support on a toothed rail
- Fixing your own shield support at the shield connection of the motor connector

Shield support with shield plate supplied

A shield plate is always provided with the screw version of the motor connector. The shield of a prefabricated motor power cable should be preferably connected at this shield plate that is provided.

Table 12- 26 Possible mounting options for the shield connection plate with recommended conductor stripped lengths

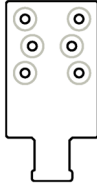
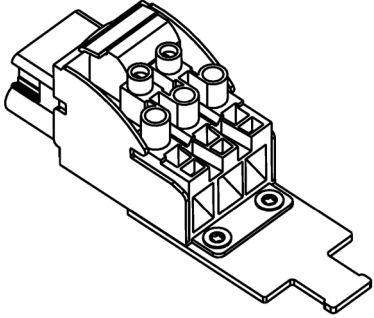
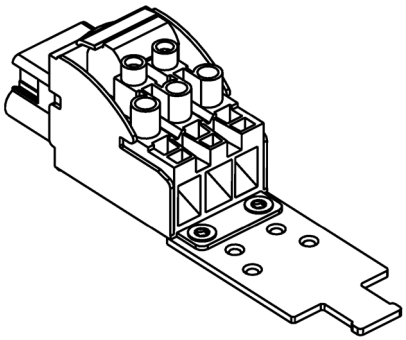
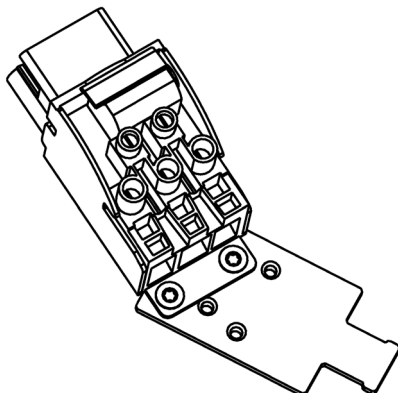
	
<p>Shield plate supplied for the motor connector</p>	<p>Version 1: Lengths in mm and (inches) a = 45 ^{-0/+2} (1.77 ^{-0/+0.08}) b = 12 ^{±0.5} (0.47 ^{±0.20}) c = 57 ^{-1/+2} (2.24 ^{-0.04/+0.08}) d = 10 ^{±0.5} (0.39 ^{±0.20})</p>
	
<p>Version 2: Lengths in mm and (inches) a = 60 ^{-0/+2} (2.36 ^{-0/+0.08}) b = 12 ^{±0.5} (0.47 ^{±0.20}) c = 77 ^{-1/+2} (3.03 ^{-0.04/+0.08}) d = 10 ^{±0.5} (0.39 ^{±0.20})</p>	<p>Version 3: Lengths in mm and (inches) a = 67 ^{-0/+2} (2.64 ^{-0/+0.08}) b = 12 ^{±0.5} (0.47 ^{±0.20}) c = 82 ^{-1/+2} (3.23 ^{-0.04/+0.08}) d = 10 ^{±0.5} (0.39 ^{±0.20})</p>

The shield plate can be mounted at various angles at the motor connector using two screws (M4) that are provided (tightening torque: 1.8 Nm / 15.9 lbf in).

Mount the shield plate with the recesses facing upwards. Otherwise the shield plate will not be able to be tightened. It is then no longer guaranteed that the shield plate is mounted so that there is a reliable electrical connection.

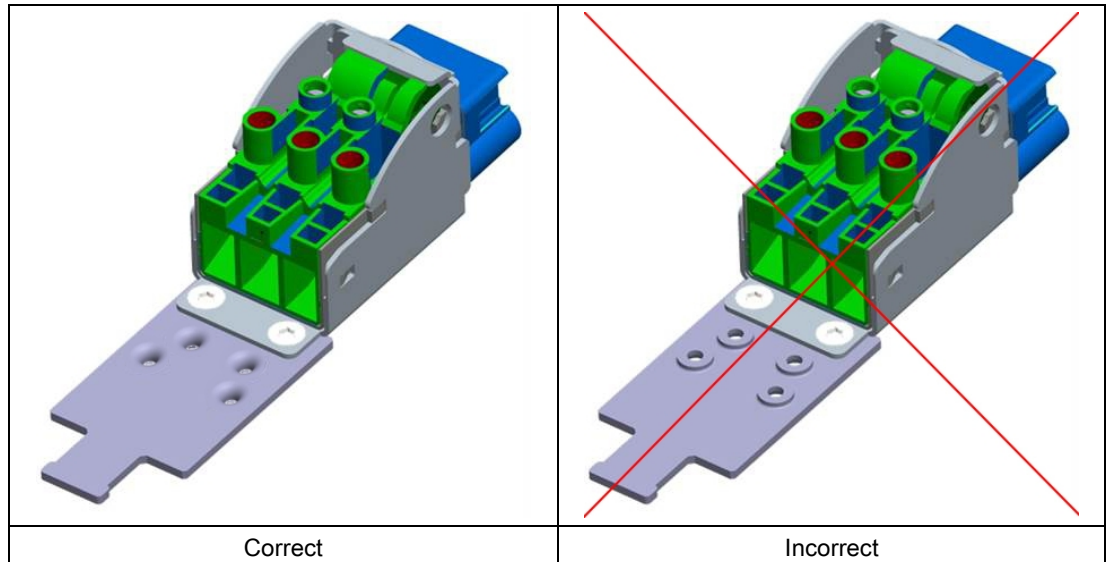

Note

In order to guarantee that the cable shield is connected through a large surface area, the motor power cable is attached with a steel hose clamp at the shield plate.

The shield is connected as shown below.

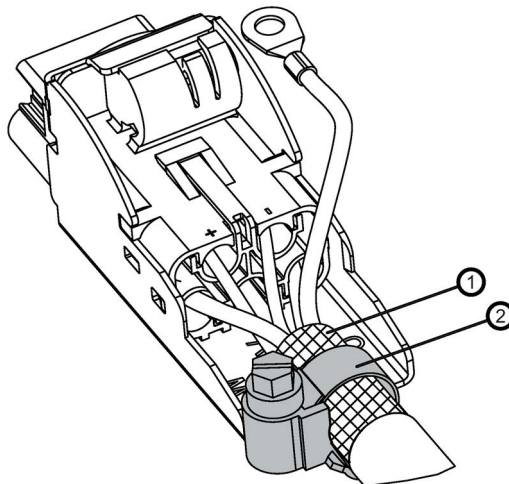

- ① Protective braided shield
- ② Steel hose clamp

Figure 12-30 Shield connection using a motor connector, crimped version, as example

Shield support on a toothed rail

The toothed rail should be mounted at a distance of ≤ 150 mm below the drive line-up to ensure a good contact. Wherever possible, the brake conductors must be kept physically separate from U/V/W connections.

Note

Measures must be taken on site to relieve strain on the cables.
The maximum permissible tensile load in the insertion direction is 100 N.

With these versions, the shield for the brake connection conductors must be routed together with the cable shield.

Attaching the motor connector

The connections for the single conductors at the motor connector can be taken from the following diagram.

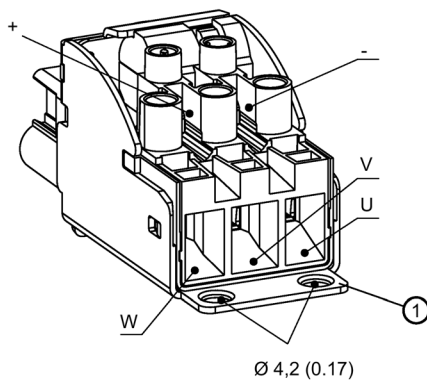

- ① Connection for shield plate supplied with the equipment

Figure 12-31 Connections at the motor connector, screw version

The motor connector is connected as shown below.

1. Insert the individual U, V, W conductors into the associated terminals of the motor connector (maximum cross-section for cables with end sleeves according to DIN 46228-E: 10.0 mm² / AWG 8).
2. Insert the individual conductors of the motor holding brake into the associated terminals of the motor connector (maximum cross-section for cables with end sleeves according to DIN 46228-A: 1.5 mm² / AWG 16).

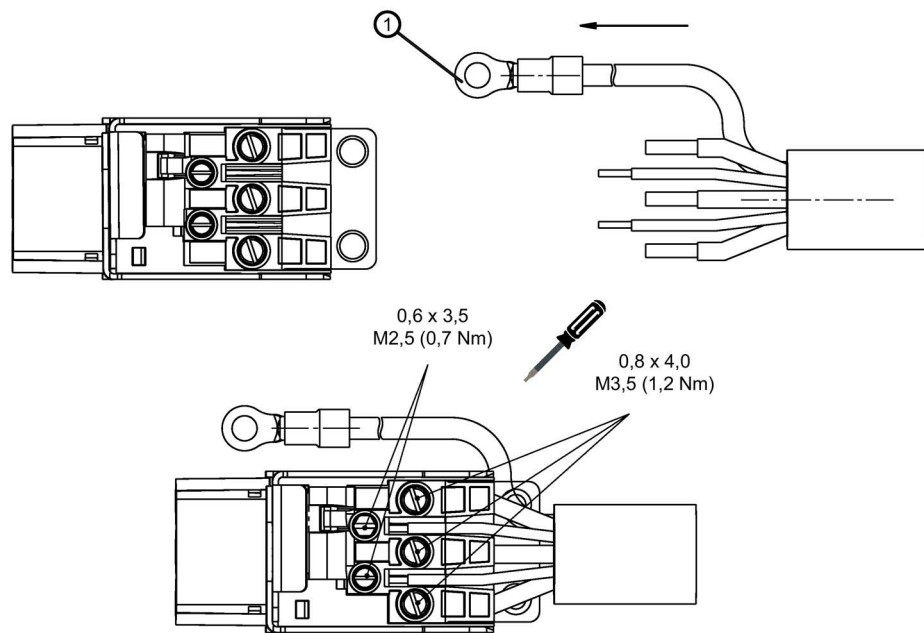

① Insulated ring cable lug

Figure 12-32 Attaching the motor connector screw version

12.7.6.3 Removing the motor connector from prefabricated power cables

The motor connector of a pre-assembled motor cable might have to be removed if the cable needs to be routed through narrow cable glands, for example.

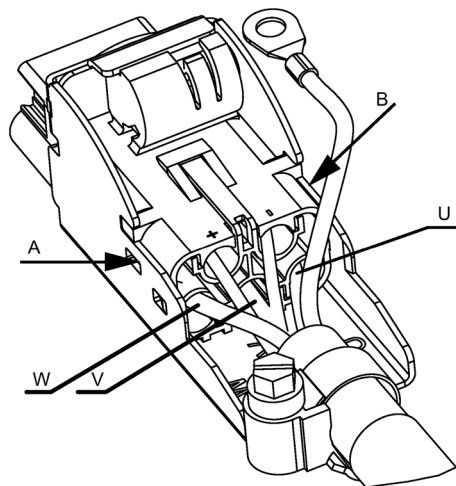

Figure 12-33 Motor connector, crimped version

Removing the motor connector

1. First loosen the clamp.
2. Simultaneously press the tabs A and B on both sides of the connector using a screwdriver.
3. Keep both tags pressed and lift the interlock mechanism e.g. using a screwdriver.
4. Remove the Insert and withdraw the motor cable out of the connector.

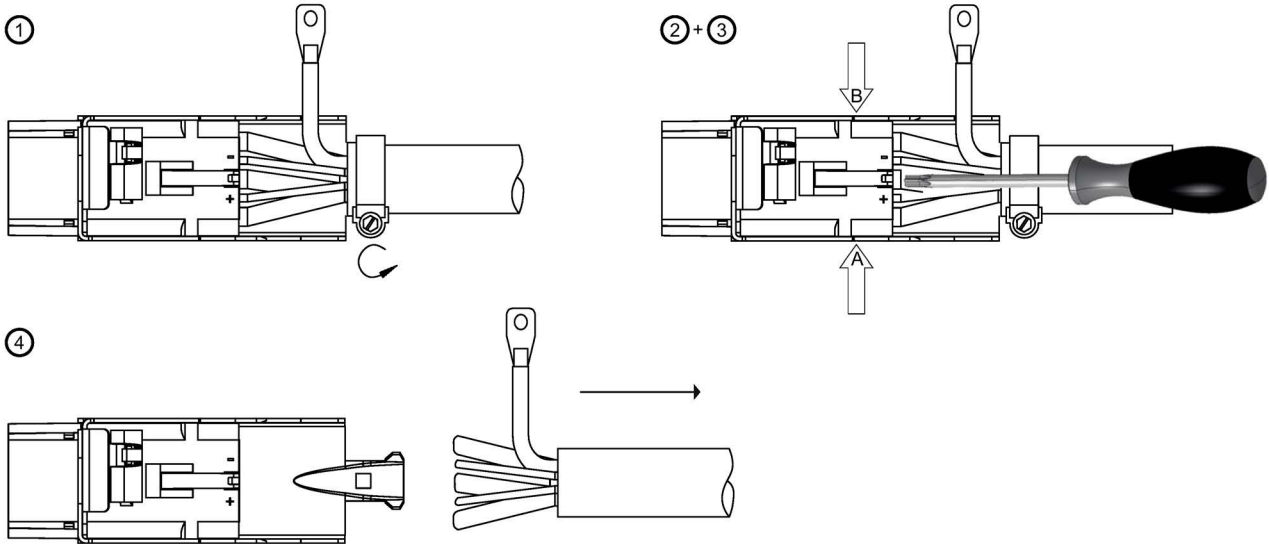

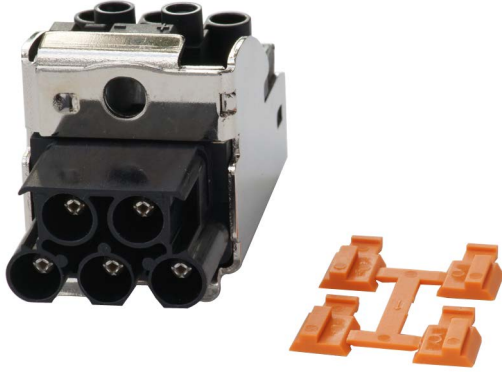

Figure 12-34 Removing the motor connector, crimped version

12.7.6.4 Coding

The motor connector is coded using coding plugs. The coding plugs are included in the scope of supply of the motor connector. Coding can be used to prevent motor cables being incorrectly connected, particularly in the case of Double Motor Modules.

The coding of a motor connector is illustrated below, using the example of a connector with screwed joint.

Table 12- 27 Coding of a motor connection plug

 A black metal motor connector with four circular ports on the front. To its right are four orange plastic coding plugs arranged in a cross pattern.	 The same black metal motor connector, but now with the four orange coding plugs inserted into the top of the front panel, partially covering the ports.
Motor connector with associated coding plugs from the accessories pack	Motor connector with coding plugs inserted

12.7.7 Spring-loaded terminals

The type of spring-loaded terminal can be taken from the interface description of the particular component.

Table 12- 28 Connectable conductor cross-sections for spring-loaded terminals

Spring-loaded terminal type			
1	Connectable cable cross-sections	Rigid Flexible Flexible with end sleeve without plastic sleeve AWG/kcmil	0.14 ... 0.5 mm ² 0.14 ... 0.5 mm ² 0.25 ... 0.5 mm ² 26 ... 20
	Stripped length	8 mm	
2	Connectable cable cross-sections	Flexible	0.08 ... 2.5 mm ²
	Stripped length	8 ... 9 mm	
3	Connectable cable cross-sections	Rigid Flexible Flexible with end sleeve without plastic sleeve Flexible with end sleeve with plastic sleeve AWG/kcmil	0.2 ... 1.5 mm ² 0.2 ... 1.5 mm ² 0.25 ... 1.5 mm ² 0.25 ... 0.75 mm ² 24 ... 16
	Stripped length	10 mm	
4	Connectable cable cross-sections	AWG	25 ... 95 mm ² 4 ... 4/0
	Stripped length	35 mm	
5	Connectable cable cross-sections	Rigid Flexible Flexible with end sleeve without plastic sleeve Flexible with end sleeve with plastic sleeve AWG/kcmil	0.2 ... 10 mm ² 0.2 ... 6 mm ² 0.25 ... 6 mm ² 0.25 ... 4 mm ² 24 ... 8
	Stripped length	15 mm	

12.7.8 Screw terminals

The type of screw terminal can be taken from the interface description of the particular component.

Table 12- 29 Connectable conductor cross-sections and tightening torques for screw terminals

Screw terminal type			
1	Connectable cable cross-sections	Rigid, flexible With end sleeve, without plastic sleeve With end sleeve, with plastic sleeve AWG / kcmil	0.08 ... 1.5 mm ² 0.25 ... 1.5 mm ² 0.25 ... 0.5 mm ² 28 ... 14
	Stripped length	7 mm	
	Tool	Screwdriver 0.4 x 2.0 mm	
	Tightening torque	0.22 ... 0.25 Nm (1.9 ... 2.2 lbf in)	

Screw terminal type			
1_1	Connectable cable cross-sections	Rigid, flexible With end sleeve, without plastic sleeve With end sleeve, with plastic sleeve AWG / kcmil	0.14 ... 1.5 mm ² 0.25 ... 1.5 mm ² 0.25 ... 0.5 mm ² 26 ... 14
	Stripped length	7 mm	
	Tool	Screwdriver 0.4 x 2.5 mm	
	Tightening torque	0.22 ... 0.25 Nm (1.9 ... 2.2 lbf in)	
2	Connectable cable cross-sections	Rigid, flexible With end sleeve, without plastic sleeve With end sleeve, with plastic sleeve AWG / kcmil	0.2 ... 2.5 mm ² 0.2 ... 2.5 mm ² 0.2 ... 1.5 mm ² 22 ... 12
	Stripped length	6 ... 7 mm	
	Tool	Screwdriver 0.5 x 3 mm	
	Tightening torque	0.4 ... 0.5 Nm (3.5 ... 4.4 lbf in)	
3	Connectable cable cross-sections	Flexible With end sleeve, without plastic sleeve With end sleeve, with plastic sleeve AWG / kcmil	0.2 ... 2.5 mm ² 0.25 ... 1 mm ² 0.25 ... 1 mm ² 22 ... 12
	Stripped length	9 mm	
	Tool	Screwdriver 0.6 x 3.5 mm	
	Tightening torque	0.5 ... 0.6 Nm (4.4 ... 5.3 lbf in)	
4	Connectable cable cross-sections	Flexible With end sleeve, without plastic sleeve With end sleeve, with plastic sleeve	0.2 ... 4 mm ² 0.25 ... 4 mm ² 0.25 ... 4 mm ² 22 ... 10
	Stripped length	7 mm	
	Tool	Screwdriver 0.6 x 3.5 mm	
	Tightening torque	0.5 ... 0.6 Nm (4.4 ... 5.3 lbf in)	
5	Connectable cable cross-sections	Flexible With end sleeve, without plastic sleeve With end sleeve, with plastic sleeve AWG / kcmil	0.5 ... 6 mm ² 0.5 ... 6 mm ² 0.5 ... 6 mm ² 20 ... 8
	Stripped length	12 mm	
	Tool	Screwdriver 1.0 x 4.0 mm	
	Tightening torque	1.2 ... 1.5 Nm (10.6 ... 13.3 lbf in)	
6	Connectable cable cross-sections	Flexible With end sleeve, without plastic sleeve With end sleeve, with plastic sleeve AWG / kcmil	0.5 ... 10 mm ² 0.5 ... 10 mm ² 0.5 ... 10 mm ² 20 ... 6
	Stripped length	11 mm	
	Tool	Screwdriver 1.0 x 4.0 mm	
	Tightening torque	1.5 ... 1.8 Nm (13.3 ... 15.9)	
7	Connectable cable cross-sections	0.5 ... 16 mm ² (AWG 20 ... 4)	
	Stripped length	14 mm	
	Tool	Screwdriver 1.0 x 4.0 mm	
	Tightening torque	1.5 ... 1.7 Nm (13.3 ... 15.0 lbf in)	

12.7.9 Cable lugs

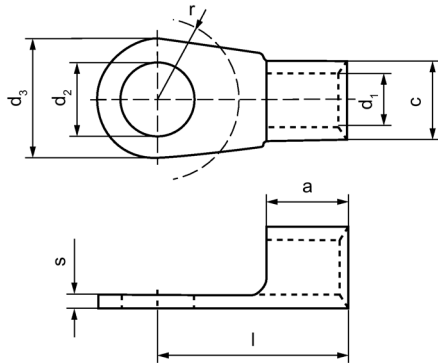

Figure 12-35 Dimension drawing of cable lugs

Table 12- 30 Dimensions of cable lugs

Screw/bolt	Cable cross-section [mm ²]	a [mm]	c [mm]	d ₁ [mm]	d ₂ [mm]	d ₃ [mm]	l [mm]	r [mm]	s [mm]
M5	1 - 2.5	5	4.5	2.3	5.3	10	14	6.5	0.8
M5	2.5 - 6	6	6	3.6	5.3	10	15	6.5	1
M5	6 - 10	8	8	4.5	5.3	10	16	6.5	1.1
M5	10 - 16	10	10.5	5.8	5.3	11	20	7.5	1.2
M6	2.5 - 6	6	6	3.6	6.5	11	16	7.5	1
M6	6 - 10	8	8	4.5	6.5	11	17	7.5	1.1
M6	10 - 16	10	10.5	5.8	6.5	11	20	7.5	1.2
M6	16 - 25	11	12	7.5	6.5	12	25	7.5	1.5
M6	25 - 35	12	15	9	6.5	15	26	9.5	1.6
M6	35 - 50	16	17	11	6.5	15	26	9.5	1.6
M6	50 - 70	18	21	13	6.5	22	38	12	2
M8	10 - 16	10	10.5	5.8	8.4	14	22	10	1.2
M8	16 - 25	11	12	7.5	8.4	16	25	10	1.5
M8	25 - 35	12	15	9	8.4	16	26	10	1.6
M8	35 - 50	16	17	11	8.4	18	34	10	1.8
M8	50 - 70	18	21	13	8.4	22	38	12	2
M8	70 - 95	20	23	15	8.4	24	42	12	2.5
M8	95 - 120	22	24	16.5	8.4	24	44	12	3
M10	35 - 50	16	17	11	10.5	18	34	12	1.8

12.7.10 Handling restrictor collars for touch protection

Handling restrictor collars for touch protection and when connecting cables

Restrictor collars are used to provide touch protection in accordance with IEC 60529. They must be removed and adapted if necessary before the line supply conductor and/or motor cable is connected, after which they must be reattached. To adapt the touch protection, see Connecting the power cables (Page 596).

Exception: The cross-section of the connected cables is large enough to ensure that the threaded bolts and the ends of the cables cannot be touched when the cover is closed.

The following components are supplied with restrictor collars as standard:

- Active Line Modules 36 kW and higher
- Smart Line Modules 36 kW and higher
- Basic Line Modules 100 kW and higher
- Motor Modules 45 A and higher
- Active Interface Modules 80 kW and higher

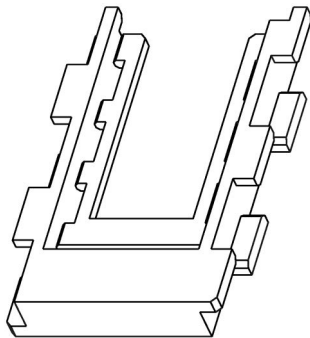

Restrictor collar

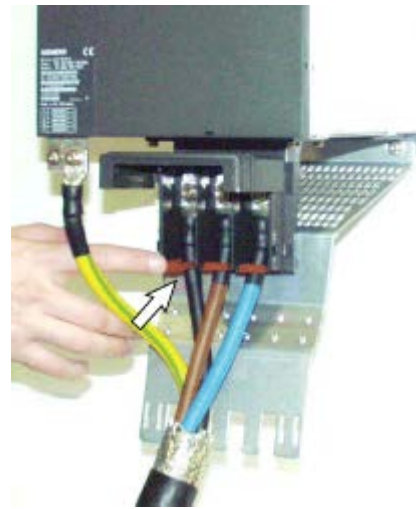

Power unit with cables and restrictor collars attached

12.8 Cable shielding and routing

In order to comply with the EMC requirements, certain cables must be routed apart from other cables and from certain components. To satisfy EMC requirements, the following cables must be used with shields:

- Line supply conductors from line filter via line reactor to Line Module
- All motor cables (if necessary, including cables for motor holding brake)
- Cables for "fast inputs" of the Control Unit
- Cables for analog direct voltage/current signals
- Signal cables for sensors
- Cables for temperature sensors

Supplementary conditions

- Alternative measures (e.g. routing behind mounting plates, suitable clearances) can also be used provided they have similar results. This excludes measures that relate to the design, installation, and routing of motor power cables and signal cables.
- If unshielded cables are used between the line supply connection point and line filter, make sure that no interfering cables are routed in parallel.
- Power and signal cables must always be routed separately. For this purpose, it is practical to arrange the various cables according to cable groups. Cables belonging to a group can be combined in a bundle. The various cable groups must be routed with the necessary clearance between them. A minimum clearance of 20 cm has proven itself in practice. As an alternative, shielding plates with the appropriate contacts at several locations can be used between the cable bundles.
- All cables inside the cabinet must be routed as closely as possible to parts connected with cabinet ground, such as a mounting plate or cabinet wall. Ducts made of sheet steel or cables routed between steel sheets (e.g. between the mounting plate and back wall) should provide adequate shielding.
- All cables must be kept as short as possible, to minimize the antenna effect.
- Signal and power cables may cross each other (if absolutely necessary), but must never be routed closely to one and other in parallel over longer distances.
- Signal cables must be routed with a minimum clearance of 20 cm from strong magnetic fields (motors, transformers). Alternatively, shield plates with the appropriate contacts at several locations along their length can be used to provide the appropriate clearance.
- Cables for the 24 V supply should be treated just like signal cables.
- Avoid, where possible, routing unshielded cables, connected to the drive line-up, in the immediate vicinity of noise sources, e.g. transformers. Signal cables (shielded and unshielded) connected to the drive line-up must be laid at a great distance from strong external magnetic sources (e.g. transformers, line reactors). In both cases, a distance of ≥ 300 mm is usually sufficient.

Shield connection

The cable shields must be connected as close to the conductor terminal connections as possible to ensure a low-impedance connection with cabinet ground. For power cables from Siemens in which the shield is connected to the connector shell (see relevant catalog), this is a sufficiently good shield support.

For components that do not have any special shield connection or where the shield connection is not sufficient, the cable shields can be connected to the metal mounting plate using hose clamps and toothed rails. The cable length between the shield contact point and the terminals for cable conductors must be kept as short as possible.

Shield contact plates with pre-prepared clip contacts are available for contacting the shields for power cables of Line Modules and Motor Modules. Up to a module width of 100 mm (inclusive), these plates are part of the scope of delivery of the components, or they are integrated in the connector.

Routing 24 V cables

When routing 24 V cables, the following must also be observed:

- A maximum of one conductor pair may be bundled together.
- 24 V conductors must be routed separately from other cables and conductors that could conduct the operating current.
- 24 V cables must never be routed parallel to power cables.
- 24 V cables as well as power cables should be routed to the components so that they never cover ventilation slots.

Conditions of use for 24 V cables

- Ambient temperature: 55 °C
- Conductor limit temperature: $\leq 70^{\circ}$ C for operation with the rated load current
- Max. cable length: 30 m for 24 V power supply cables and for signal cables without additional circuitry
Surge voltage protection devices must be used for longer cable lengths.

12.9 Protective connection and equipotential bonding

Protective connections

The SINAMICS S Booksize drive system is designed for use in cabinets with a PE conductor connection.

The protective conductor connection of the SINAMICS components must be connected to the protective conductor connection of the control cabinet as follows:

Table 12- 31 Conductor cross-section for copper protective connections

Line supply cable in mm ²	Copper protective connection in mm ²
Up to 16 mm ²	The same as the line supply cable
From 16 mm ² to 35 mm ²	16 mm ²
From 35 mm ²	0.5 x line supply cable

The values listed in this table are applicable if the protective conductor is manufactured out of the same metal as the line conductors. If this is not the case, then the protective conductor cross-section must be determined so that a level of conductivity is obtained that is as a minimum, the same as the data listed in this table.

All system components and machine parts must be incorporated in the protection concept.

The protective connection for the motors used must be established through the motor cable.

Copper cables with the appropriate cross-section (> 2.5 mm²) must be used for the ground connection of PROFIBUS participants.

Further information about ground connection for PROFIBUS can be found at:
http://www.profibus.com/fileadmin/media/wbt/WBT_Assembly_V10_Dec06/index.html



<p>! WARNING</p> <p>Electric shock caused by high leakage currents when the protective conductor in the line feeder cable is interrupted</p> <p>The drive components conduct a high leakage current via the protective conductor. Touching conductive parts when the protective conductor is interrupted can result in death or serious injury.</p> <ul style="list-style-type: none"> Carefully comply with the applicable regulations for dimensioning the protective conductor (see below).

Protective connection concept, SINAMICS S120 booksize power units

Booksize power units should always be connected with a protective conductor to the central PE busbar or the conductive mounting plate in the control cabinet (see the following diagram).

Note

Ensure that for increased leakage currents, the local regulations for protective conductors at the installation site are complied with.

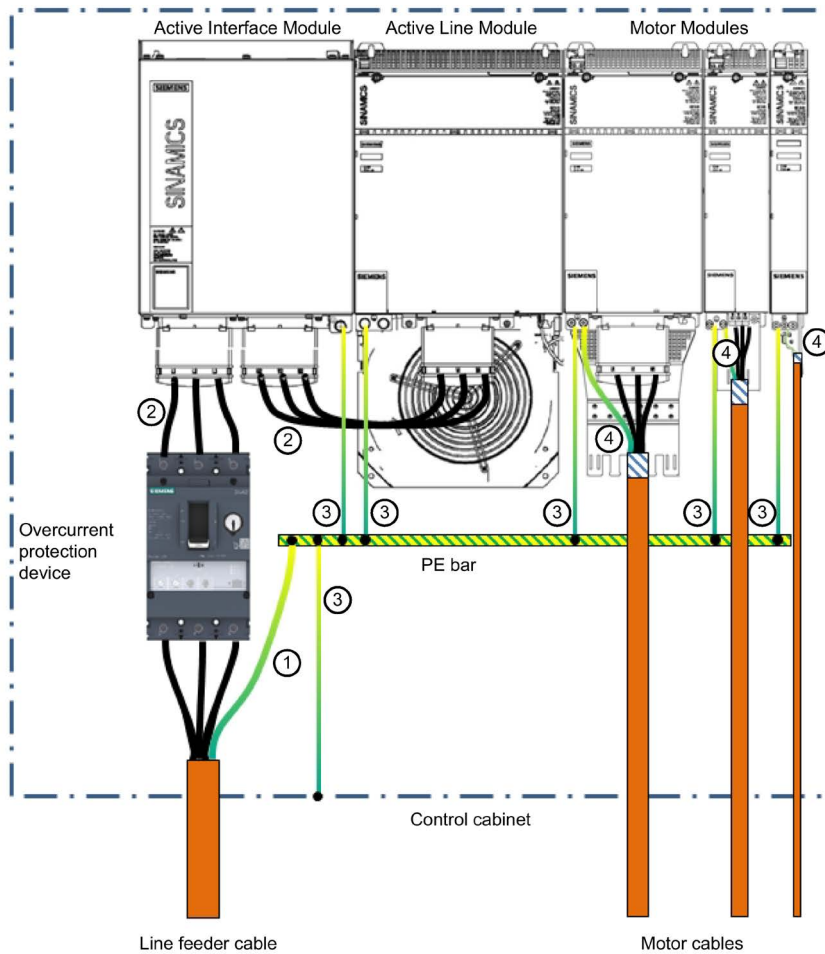

- ① The protective conductor (PE) must be dimensioned in accordance with the local installation rules for equipment with increased leakage currents. As a minimum, one of the following conditions must be satisfied:
 - The protective conductor is routed so that along its complete length it is protected against mechanical damage.
 - The protective conductor has a cross-section $\geq 10 \text{ mm}^2 \text{ Cu}$.
 - A second protective conductor with the same cross-section is provided.
 - When establishing the connection using an industrial plug connector according to EN 60309, the protective conductor of a multi-conductor cable must have a cross-section $\geq 2.5 \text{ mm}^2 \text{ Cu}$.
 - As a conductor of a multi-conductor cable, the protective conductor has a cross-section $\geq 2.5 \text{ mm}^2 \text{ Cu}$.
- ② The cable cross-section must be dimensioned in compliance with local installation rules.
- ③ The cable cross-sections must be dimensioned in compliance with local installation rules. Additional details are provided in the following document "Dimensioning the protective conductor for SINAMICS S120 Booksize (<https://support.industry.siemens.com/cs/ww/en/view/109738572>)".
- ④ Same cross-section as the line conductor of the motor cable.

Figure 12-36 Protective connection concept, SINAMICS S120 booksize

Protective connection via the mounting plate

Alternative to the described methods with protective conductors, it is also possible to establish the protective conductor connection of the electrical cabinet through the mounting plate, assuming that all of the following conditions are satisfied. As a consequence, the requirements placed on a protective conductor for an increased discharge current are satisfied. The marked protective conductor connections of the devices are then not assigned.

Conditions

- Only permissible for modules with internal air cooling
- Use a bare metal mounting plate that is resistant to corrosion, e.g. galvanized with a minimum thickness of 2 mm.
- Electrically conductive connection between the mounting plate and the electrical cabinet corresponding to the specifications of the electrical cabinet manufacturer.
- All module fixing screws must be screwed-in with spring washer and washer - and then tightened with the specified tightening torque. Equivalent screw fittings are permissible.
- At least one fixing screw of the module is designated as protective conductor connection with the symbol  (IEC 60417-5019).
- The continuity of the protective conductor connection must be checked, e.g. according to IEC 60204-1 Chapter 18.2.2 or IEC 60364-6 Chapter 6.4.3.2.
- Just like all power connections, the fixing screws of the modules are regularly re-tightened with the specified tightening torques.

Note

- Observe the local installation regulations.
-

Functional equipotential bonding

For EMC reasons, the shield of the motor cable should be connected through a large surface area both at the Motor Module as well as at the motor.

The drive line-up must be arranged on a single, bare metal mounting plate in order to comply with the EMC limit values. The mounting plate must be connected to the protective conductor connection of the control cabinet through a low impedance.

It simultaneously serves as a functional equipotential bonding surface. This means that no additional functional equipotential bonding is required within the drive line-up.

If a single, bare metal mounting plate is not available, then equally good functional equipotential bonding must be established using cable cross-sections as listed in the table above or, as a minimum, with the same conductivity.

When mounting components on standard mounting rails, the data listed in the table apply. If only smaller conductor cross-sections are permissible on components, the largest cross-section must be used (e.g. 6 mm² for TM31 and SMC). These requirements also apply to distributed components located outside the control cabinet.

No functional equipotential bonding conductors are required for PROFIBUS inside a control cabinet. For PROFIBUS connections between different buildings or parts of buildings, a functional equipotential bonding must be routed in parallel to the PROFIBUS cable. The following cross-sections must be observed in accordance with IEC 60364-5-54:

- Copper 6 mm²
- Aluminum 16 mm²
- Steel 50 mm²

Further information about equipotential bonding for PROFIBUS can be found at:
http://www.profibus.com/fileadmin/media/wbt/WBT_Assembly_V10_Dec06/index.html

Note

PROFINET

For installation guidelines and information of protective grounding and equipotential bonding for all PROFINET types and topologies, refer to DOWNLOADS at:
<http://www.profibus.com>

12.10 Information on cold plate cooling

12.10.1 General information

Cold plate cooling is a cooling method that can be used for SINAMICS S120 power units in booksize format. The flat aluminum cold plate (cold plate), which is located on the rear of the device, acts as a thermal interface in cold plate cooling.

The cold plate cooling is especially suitable for the following machine concepts:

- Plants and systems with high degree of pollution in the vicinity of the machine (e.g. in the textiles or timber industry).
 - Reducing cabinet-internal thermal losses facilitates cooling within a sealed cabinet (IP54).
- Plants and systems where liquid cooling is already being used in the process.
 - The existing cooling circuit can be used to externally cool the power components with cold plate.

There are 2 ways of configuring the cooling:

- Cold plate cooling with an external air heat sink
The components of the drive line-up are typically all screwed on to the cooling fins of an air heat sink located outside the control cabinet.
- Cold plate cooling with an external liquid heat sink
The components of the drive line-up are typically all screwed on to a liquid heat sink located outside the control cabinet.

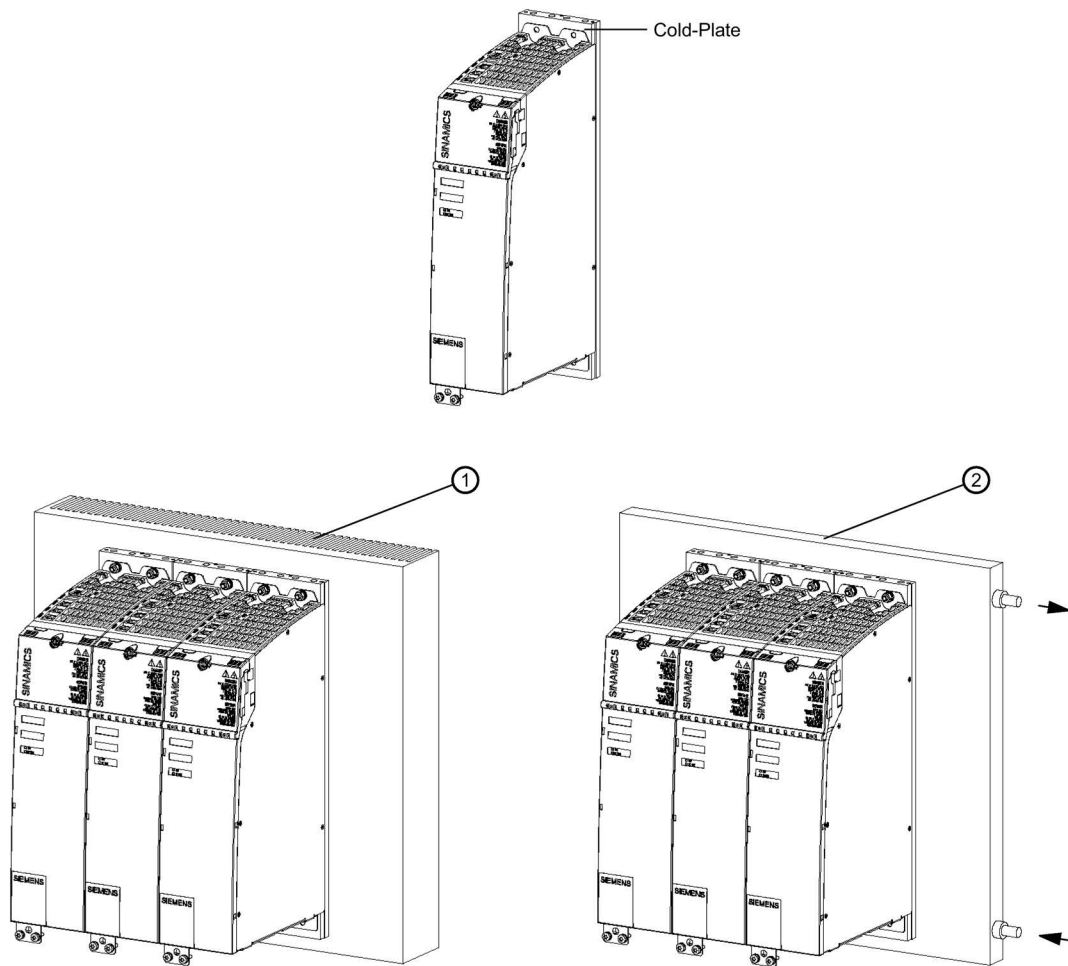

- ① Cold plate components on an external air heat sink
- ② Cold plate components on an external liquid heat sink

Figure 12-37 Overview of cooling types for drive line-ups with cold plate

12.10.2 Cold plate with external air heat sink

12.10.2.1 Configuration and conditions

The conditions described below must be taken into account when cooling a cold-plate drive line-up by means of an external air heat sink.

General conditions to be observed:

- The maximum temperature within the cabinet is 40 °C (air intake temperature of the power sections). The maximum temperature inside the cabinet is 55 °C when derating is taken into consideration.
- The maximum permissible heat-sink temperature is module-dependent. Refer to the "Technical data" for more information. A temperature sensor in the power unit measures the temperature and can be read via parameter (see SINAMICS S120/S150 List Manual).
- The customer must take measures to protect the devices against condensation (see Anti-condensation measures (Page 761)).

Note

If the components are installed in a sealed cabinet, an internal fan must be installed to prevent hot spots. It is best to install the fan above the modules to optimize the air flow (suction).

If the conditions in the plant do not allow the temperature in the cabinet to be limited to a maximum of 40 °C, further measures must be taken. Please contact the hotline for more information (see the Preface).

The power units must be arranged in such a way that the power (loss) is distributed equally. The permissible current carrying capacities of the DC link busbars in the different modules must be taken into account (see "Technical data" for the various modules).

12.10.2.2 Setup example, drive line-up, cold plate with external air heat sink

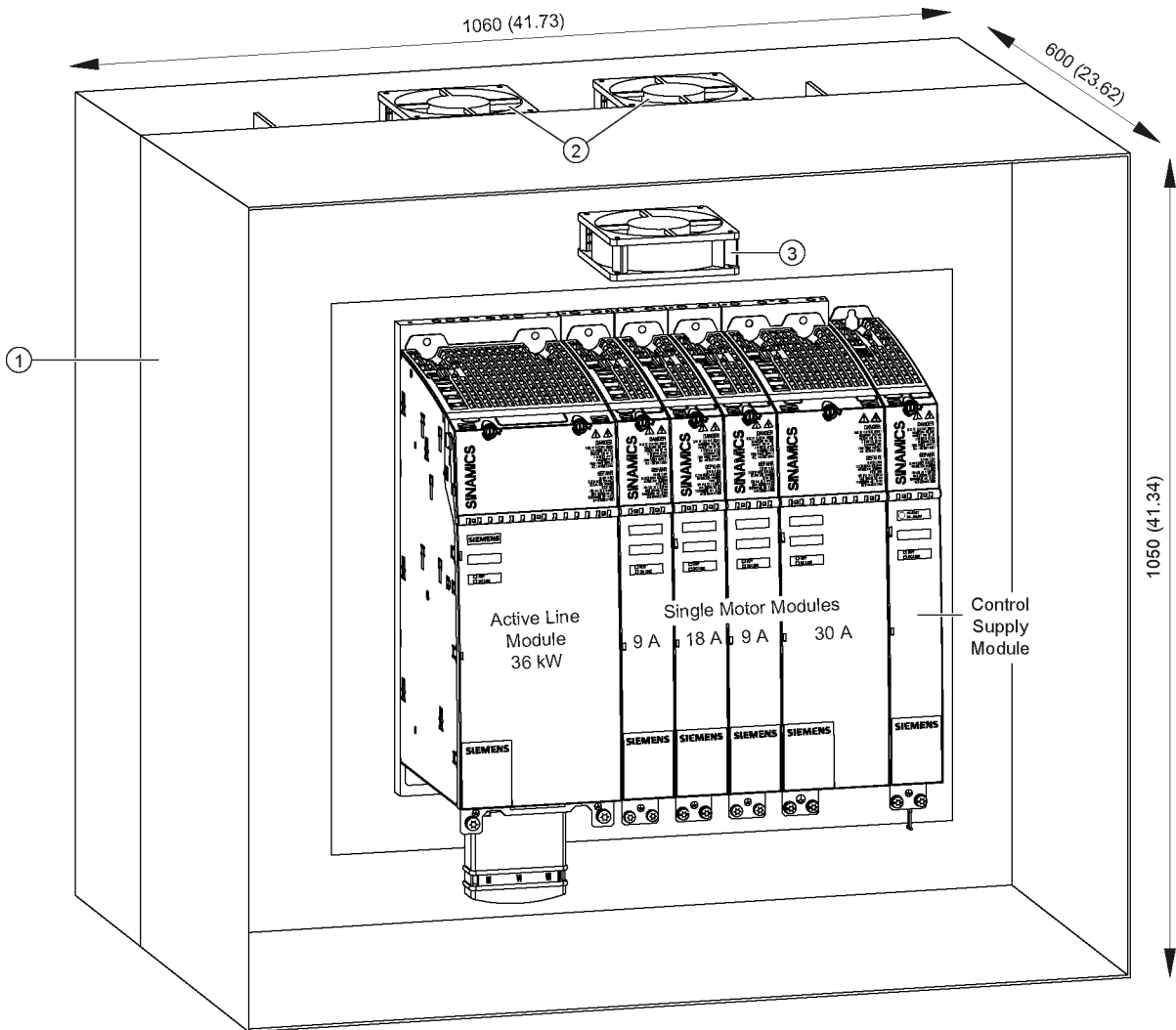

- ① Control cabinet
- ② External fan
- ③ Internal fan

Figure 12-38 Front view of a control cabinet with drive line-up, cold plate and external air heat sink

Setup:

- Infeed: Active Line Module 36 kW
- 4 Single Motor Modules
- Control Supply Module for 24 V supply
- Internal fan at the top of the control cabinet
- One shared external air heat sink

To optimize usage of the external air heat sink, it is best to arrange the components in such a way that the heat is dissipated equally over the surface of the external heat sink. This means that, if possible, a large power section should be situated next to a smaller one. The current carrying capacity of the DC-link busbars must be taken into account here.

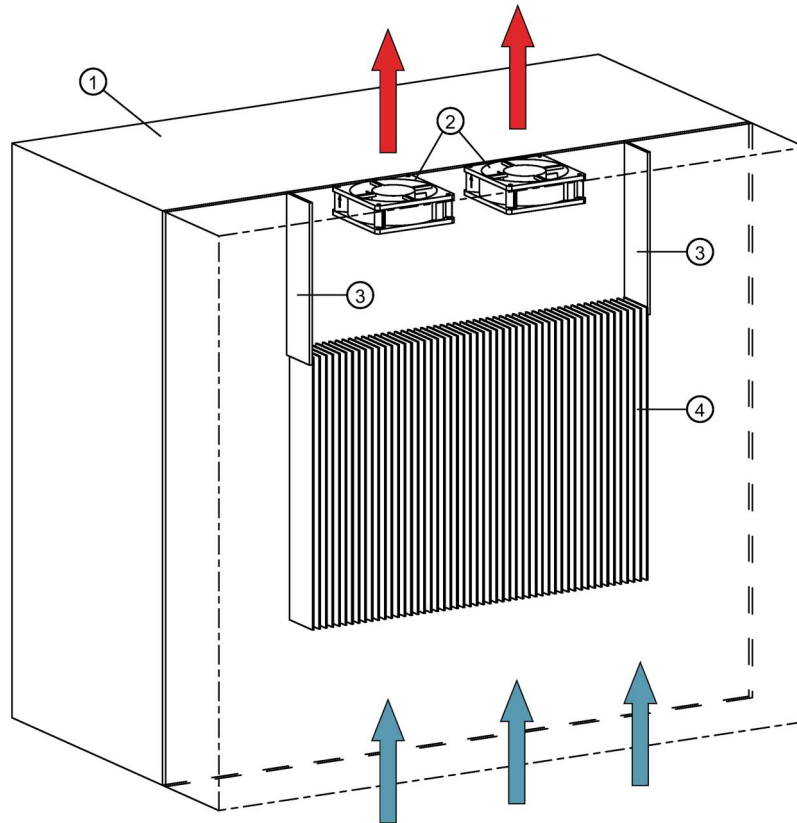

- ① Control cabinet
- ② External fan
- ③ Air baffle plates
- ④ External air heat sink

Figure 12-39 Rear view of a control cabinet with drive line-up, cold plate and external air heat sink

In this example, two axial fans with a diameter of 150 mm ensure forced convection. The ribbed heat sink, which is attached to the rear, is located in an air duct (approx. 150 mm deep). Additional air guides at the sides improve air guidance and significantly optimize the power unit cooling.

Note

The external heat sink must be sealed with respect to the control cabinet in accordance with IP65.

Example: external air heat sink

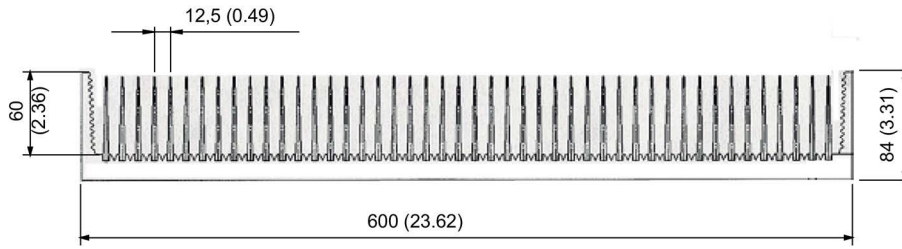

Figure 12-40 External air heat sink, all data in mm and (inches); height: 500 mm (19.69 inch)

Aluminum air heat sinks are recommended.

The heat sinks and fans must be dimensioned for the power loss to be dissipated. For the component-specific power loss in rated operation, refer to "Technical data". Appropriately lower average power losses are obtained in intermittent duty.

The heat sinks and fans are not part of the scope of supply.

Recommended suppliers for heat sinks include:

- Company Alcan company, Singen
- Company Sykatec company, Erlangen

Note

The mounting surface for the heat sink (roughness, evenness) must fulfill the requirements for the corresponding cold plate component described in the chapter titled "Installation".

12.10.3 Cold plate with an external liquid heat sink

12.10.3.1 Configuration and conditions

When an external liquid heat sink is used, the power sections are all installed on a plate through which cooling water flows to cool the power units. The size of the liquid heat sink can be adjusted in line with the size of the drive line-up.

General conditions to be observed

- The maximum temperature within the cabinet is 40 °C (air intake temperature of the power sections). The maximum temperature inside the cabinet is 55 °C when derating is taken into consideration.
- The maximum permissible heat-sink temperature is module-dependent. Refer to the "Technical data" for more information. A temperature sensor in the power unit measures the temperature and can be read via parameter (see SINAMICS S120/S150 List Manual).
- The customer must take measures to protect the devices against condensation (see Anti-condensation measures (Page 761)).

12.10.3.2 Setup example, drive-line-up, cold plate with external liquid heat sink

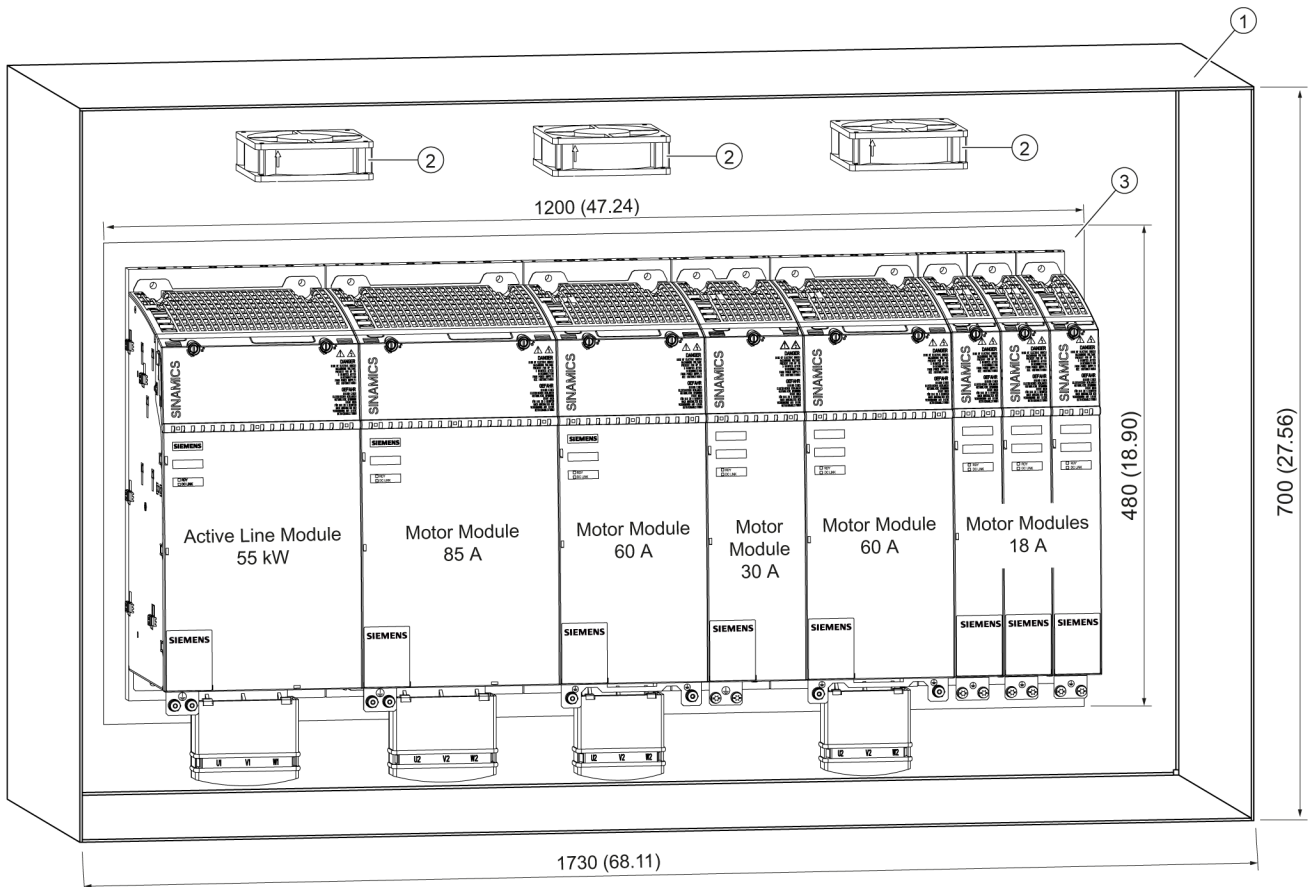

- ① Control cabinet
- ② Fan inside the control cabinet
- ③ External liquid heat sink

Figure 12-41 Example: cold plate drive line-up with external liquid cooling

Setup:

- Infeed: Active Line Module 55 kW
- 7 Single Motor Modules
- 3 internal fans at the top of the control cabinet
- 1 common external liquid heat sink (1200 mm x 480 mm)

The heat sinks and fans are not part of the scope of supply.
Recommended suppliers for liquid heat sinks include:

- Company DAU Ges.m.b.H & CO.KG., Ligist (Austria)
- Company Rittal GmbH & Co. KG, Herborn

12.11 Notes on electrical cabinet cooling

12.11.1 Control cabinet cooling options

The following options are available for cooling the control cabinet:

- Filter fans
- Heat exchangers
- Cooling unit
- Liquid cooling
- External air cooling
- External liquid cooling

The prevailing environmental conditions and the cooling power required define the method used to cool the control cabinet.

The air routing within the control cabinet and the cooling clearances specified must be observed. No components may be mounted and no cables routed in the cooling clearance spaces.

You must take into account the following specifications when installing a SINAMICS drive line-up:

- Ventilation clearance
- Wiring and cabling
- Air guidance, air-conditioner

NOTICE
Reduction of the component service lives through incorrect mounting
If you do not observe the guidelines for mounting SINAMICS components in the cabinet, this can reduce the service life of the equipment and result in premature component failure.
<ul style="list-style-type: none">• Observe the guidelines for installing SINAMICS components.

12.11.2 General information on ventilation

SINAMICS components are force-ventilated using integrated fans, in some cases through natural convection and also customized cooling methods. The fans are not equipped with temperature-dependent speed control; only the states "on" or "off" exist.

Fan operation up to firmware version 2.5

The fans are switched on and switched off as a function of the heat sink temperature.

The fans start to run at a specific heat sink temperature for the particular device. They switch themselves off with a small hysteresis as soon as the heat sink temperature falls below this threshold. The run-on time of the fan depends on various factors such as ambient temperature, output current, duty cycle and, therefore, cannot be determined directly.

Fan operation as of firmware version 2.6

The fans can be controlled as a function of the heat sink temperature.

The fans start to run at a specific heat sink temperature for the particular device – or when a pulse enable is set. They switch themselves off with a small hysteresis as soon as the heat sink temperature, which has been saved, is fallen below and there is no pulse enable. The fan run on time can be parameterized (see SINAMICS S120/S150 List Manual).

Note

For the 5 kW and 10 kW Smart Line Modules, the fan runs permanently.

Air guidance

The cooling air must flow through the components vertically from bottom (cooler region) to top (region heated by operation).

If filtered fans, heat exchangers, or air conditioners are used, you must ensure that the air is flowing in the right direction. You must also ensure that the warm air can escape at the top. A ventilation clearance of at least 80 mm above and below must be observed.

NOTICE

Damage caused by overheating resulting from covered ventilation slots
--

Covered ventilation slots can cause the system to overheat.

- | |
|---|
| <ul style="list-style-type: none">• Route the connected signal and power cables to the components in such a way that they do not cover the ventilation slots. |
|---|

Note

The distance between the discharge opening of the air condition equipment and the electronic equipment must be at least 200 mm.

Note

If the components are mounted in a sealed cabinet, an internal air cooling system must be installed to circulate the air and prevent hot spots. It is best to mount the fan above the components to optimize the air flow (suction).

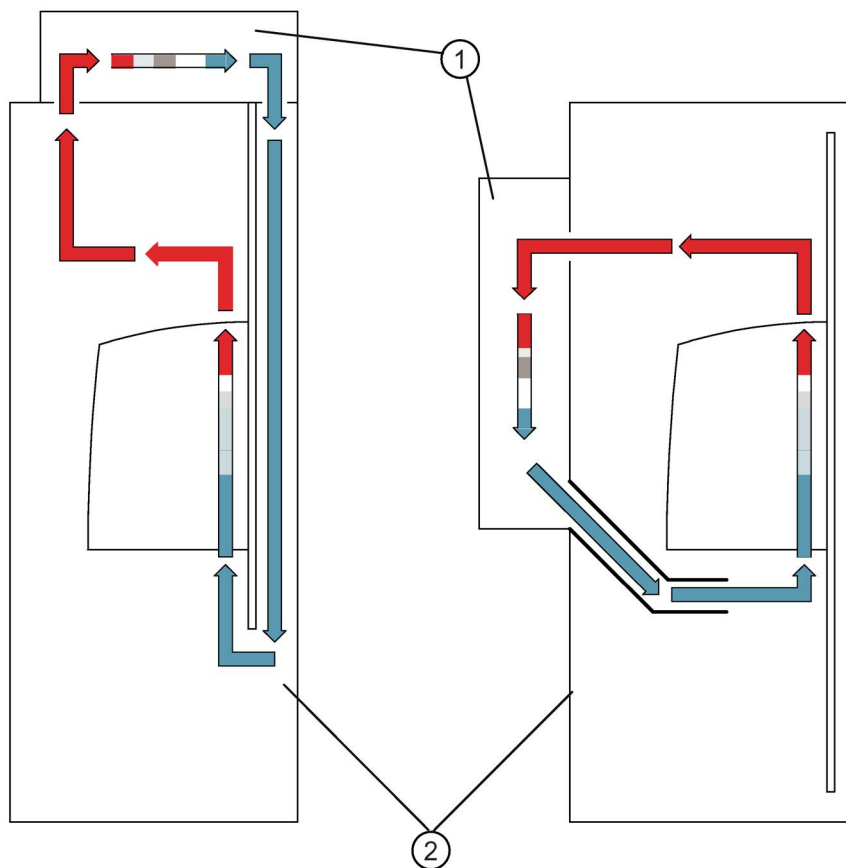

- ① Cooling unit
- ② Control cabinet

Figure 12-42 Examples of cabinet ventilation

NOTICE

Component damage caused by condensation

Condensation on the components can cause them to fail.

- Select the air circuit and arrangement of the cooling equipment in such a way that no condensation can form on the components.
- If required, an anti-condensation heater must be installed in the cabinet.

If air conditioners are used, the relative air humidity of the expelled air increases as the air in the air conditioner cools and may exceed the dew point. To avoid condensation, climate control equipment should be arranged so that cold discharged air is not directly blown onto SINAMICS components. Using air guidance baffles, ensure that the air is adequately mixed with the air inside the cabinet. This reduces the relative air humidity to uncritical values.

12.11.3 Cooling clearances

Table 12- 32 Cooling clearances required above and below SINAMICS components

Component	Clearance [mm]
CU320-2	80
Sensor Modules Cabinet-Mounted SMCxx	50
Terminal Modules TMx	50
Line filter for Line Modules	100
Active Interface Modules	80
Line reactors for Line Modules	100
Active Line Modules 16 ... 55 kW 80 ... 120 kW	80 80 (additional 50 in front of fan)
Smart Line Modules Booksize	80
Smart Line Modules Booksize Compact	80
Basic Line Modules	80
Motor Modules Booksize < 132 A 132 A/200 A	80 80 (additional 50 in front of fan)
Motor Modules Booksize Compact	80
Braking Module Booksize	80
Braking Module Booksize Compact	80
Control Supply Module	80
Capacitor Module	80
Voltage Protection Module	200

Drive line-up with internal air cooling

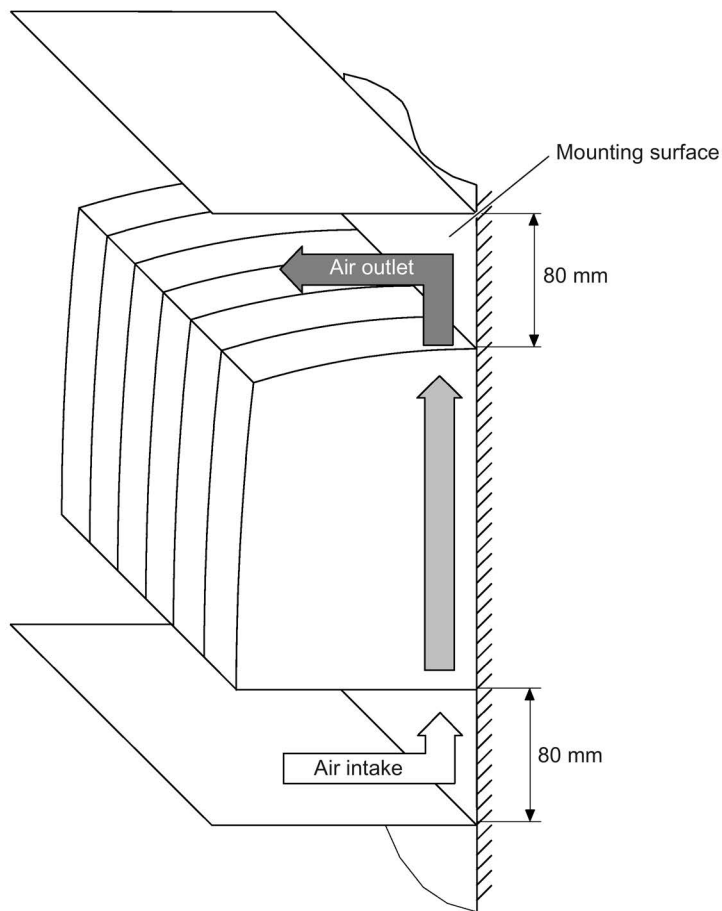

Figure 12-43 Cooling clearances for a drive line-up with internal air cooling (components up to 200 mm width)

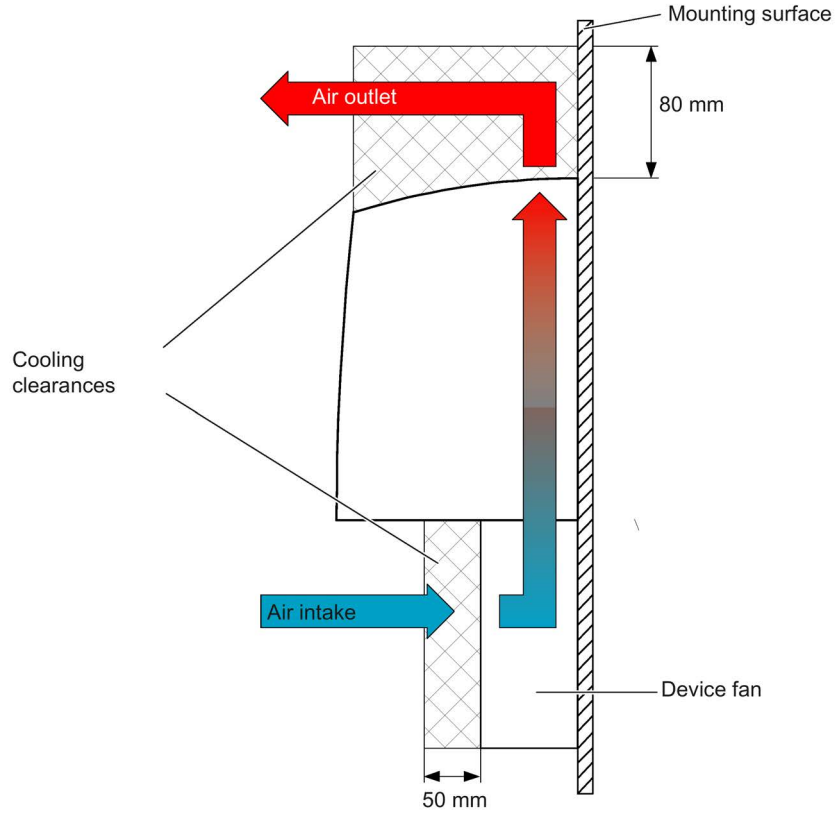

Figure 12-44 Cooling clearances for 300 mm wide components with internal air cooling with mounted unit fan

Drive line-up with external air cooling

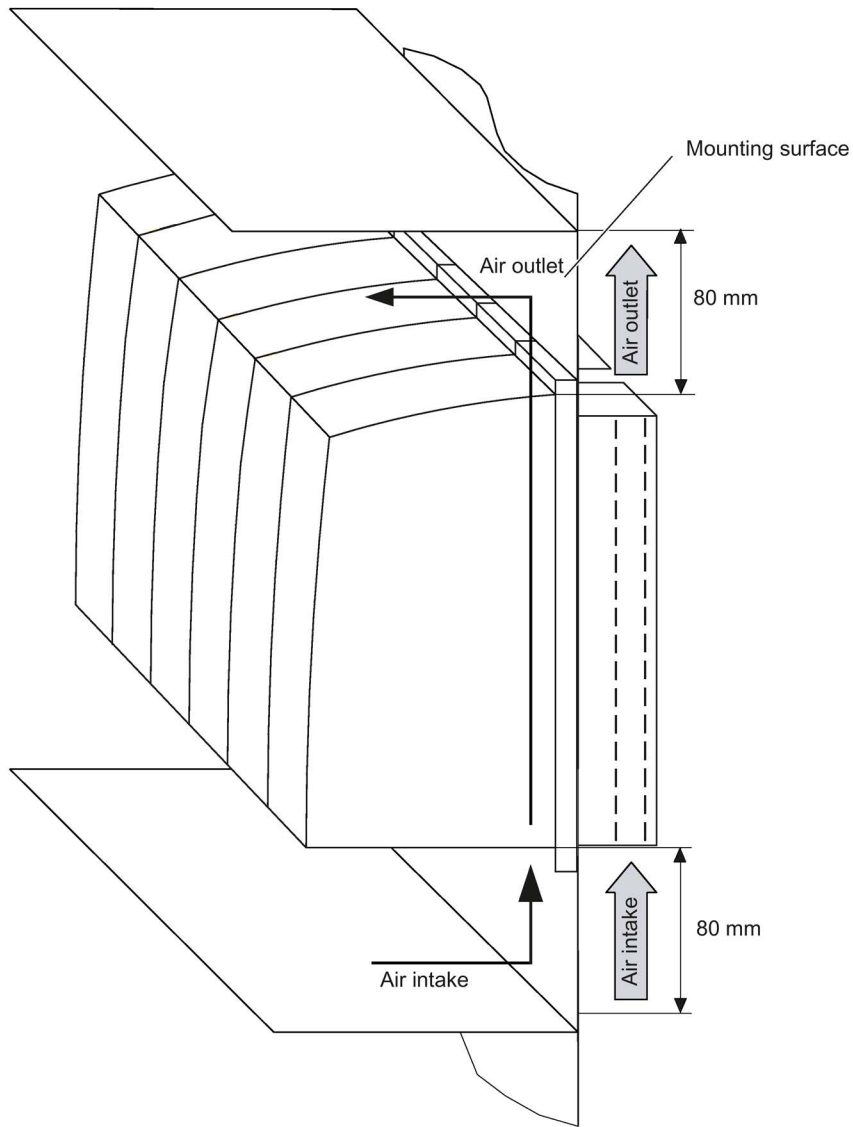

Figure 12-45 Cooling clearances for a drive line-up with external air cooling (components up to 200 mm width)

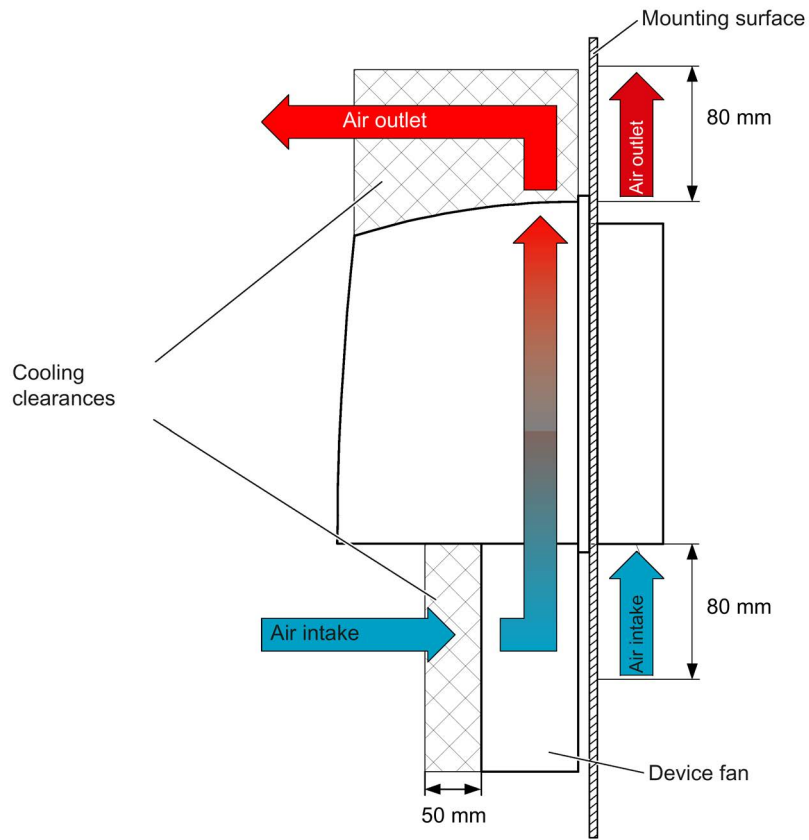

Figure 12-46 Cooling clearances for 300 mm wide components with external air cooling with mounted unit fan

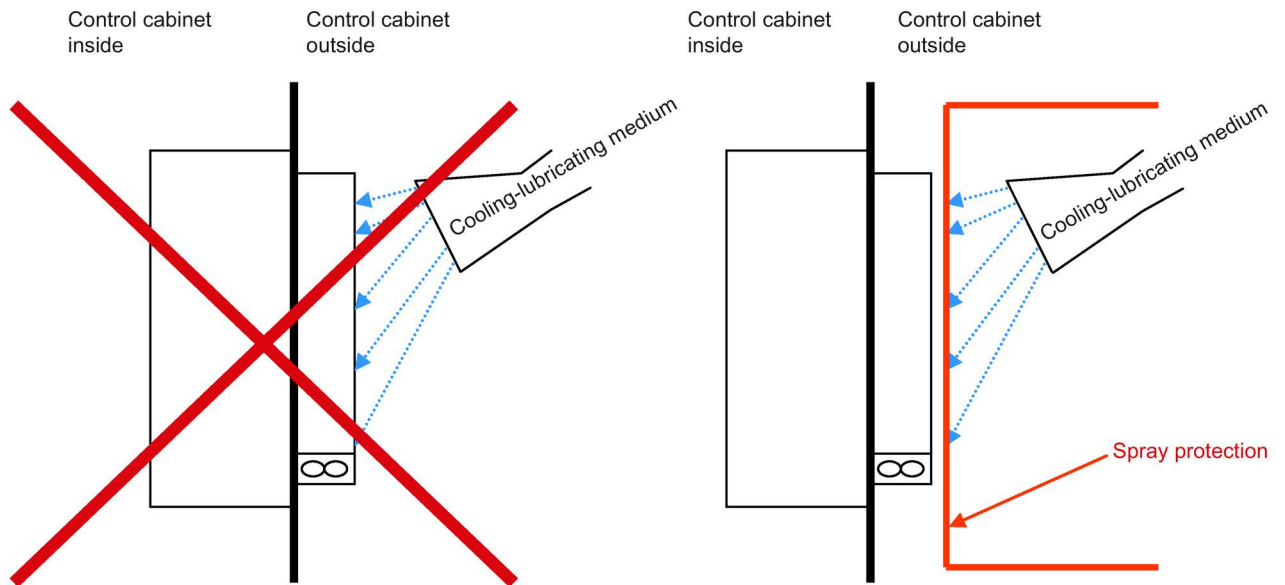

Figure 12-47 Spray protection for a drive line-up with external air cooling

Rail-mounted components

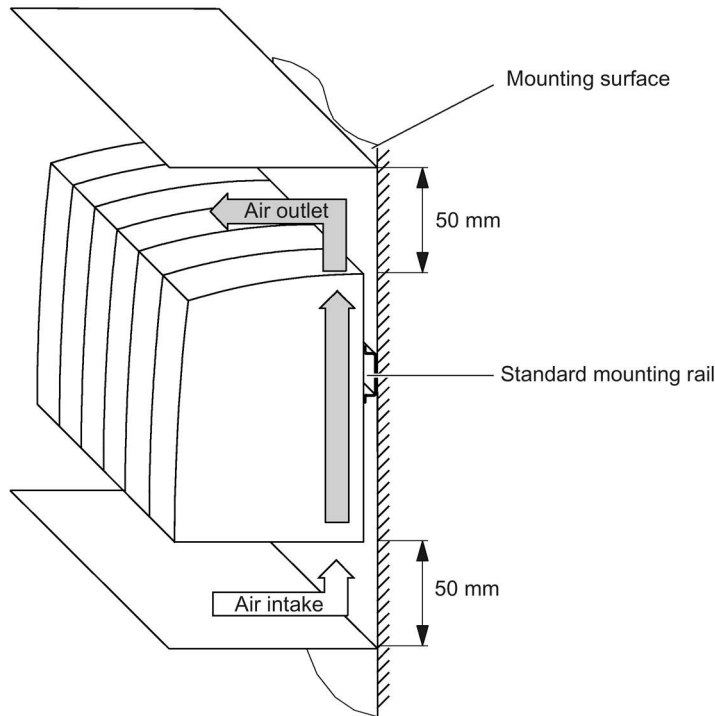

Figure 12-48 Cooling clearances for rail-mounted components (e.g. VSM, SMC, TM, DMC)

12.11.4 Notes on ventilation with cold plate

Notes on ventilation with cold plate

With cold-plate cooling, the SINAMICS devices must always be ventilated separately by means of a fan in the cabinet. Other suitable measures can be alternatively employed.

When using an external air heat sink, fans located outside the control cabinet must be additionally used. Other suitable measures can be alternatively employed.

Temperature measurement

The temperature of the power units can be read out using a parameter (see the SINAMICS S120/S150 List Manual).

Temperature limits

- For the maximum heat sink temperature, see the "Technical data" for the power units.
- For the maximum temperature inside the control cabinet, see the "Technical data" for the power units.

Measures for remaining within temperature limits

- One or more fans should be installed.
- If necessary, the drive line-up can be operated with derating.

12.11.5 Dimensioning Climate Control Equipment

Cabinet manufacturers provide calculation programs for selecting climate control equipment. It is always necessary to know the power loss of the components and equipment installed in the cabinet.

The physical relationship is shown in the following example.

$$q = Q - k \times A \times \Delta T$$

Formula to calculate the power loss

q = thermal power that has to be dissipated through a cooling unit [W]

Q = power loss [W]

ΔT = temperature difference between the room and cabinet interior [K]

k = thermal resistance coefficient [W / (m² * K)]

(example: sheet steel, painted: k = 5.5 W / (m² * K))

A = free-standing cabinet surface area [m²]

Table 12- 33 Example, calculating the power loss of a drive configuration

Component	Quantity	Total power loss [W] (including electronic losses)	Total power loss [W]
CU320-2	1	24	24
Basic Line Filter for AIM / ALM 36 kW	1	26	26
Active Interface Module	1	340	340
Active Line Module 36 kW	1	666	666
Motor Module 18 A	2	185.4	370.8
Motor Module 30 A	3	309.2	927.6
SMC	5	10	50
SITOP 20	1	53	53
Line contactor	1	12	12
Total:			2469.4

Assumption:

Free-standing cabinet surface area A = 5 m²

Temperature difference between the room and cabinet interior $\Delta T = 10$ K

$$q = 2469.4 \text{ W} - 5.5 \text{ W} / (\text{m}^2 \text{ K}) * 5 \text{ m}^2 * 10 \text{ K} = 2194.4 \text{ W}$$

12.12 Power losses of the components

12.12.1 General information

The tables below provide an overview of the power loss of all components during rated operation. The characteristic values apply for the following conditions:

- Line voltage for Line Modules 400 V
- Pulse frequency of the Motor Modules 4 kHz
- Rated pulse frequency of the Active Line Modules 8 kHz
- Operating components at their rated power

The total losses of the relevant power unit (Line Module, Motor Module) are calculated from the power loss and the corresponding electronics loss of the power unit.

12.12.2 Power loss for Control Units, Sensor Modules, and other system components

Table 12- 34 Overview of power loss during rated operation for Control Units, Sensor Modules, and other system components

	Unit	Power loss
Control Units and Option Boards		
CU320-2	W	24
TB30	W	< 3
CBC10	W	< 3
CBE20	W	2.8
Sensor Modules		
SMC10	W	< 10
SMC20	W	< 10
SMC30	W	< 10
SME20/25	W	≤ 4
SME120/125	W	≤ 4.5
Terminal Modules		
TM15	W	< 3
TM31	W	< 10
TM41	W	12
TM54F	W	4.5
Additional system components		
VSM10	W	< 10
DC link components		
Braking Module Booksize	W	20
Braking Module Booksize Compact	W	< 40

	Unit	Power loss
Capacitor Module	W	25
Control Supply Module	W	70
Line DC link		

12.12.3 Power loss for line filters and line reactors

Table 12- 35 Overview of power loss during rated operation for line filters and line reactors

	Unit	Power loss
Basic Line Filters for Active Line Modules		
16 kW	W	16
36 kW	W	26
55 kW	W	43
80 kW	W	56
120 kW	W	73
Basic Line Filter for Active Line Modules with Active Interface Module		
16 kW	W	16
36 kW	W	26
55 kW	W	43
80 kW	W	56
120 kW	W	73
Basic Line Filter for Smart Line Modules		
5 kW	W	5
10 kW	W	9
16 kW	W	16
36 kW	W	26
55 kW	W	43
Basic Line Filter for Basic Line Modules		
20 kW	W	16
40 kW	W	26
100 kW	W	73
Active Interface Modules		
16 kW	W	270 ¹⁾
36 kW	W	340 ¹⁾
55 kW	W	380 ¹⁾
80 kW	W	490 ¹⁾
120 kW	W	585 ¹⁾
Line reactors for Active Line Modules		
16 kW	W	170
36 kW	W	250

12.12 Power losses of the components

	Unit	Power loss
55 kW	W	350
80 kW	W	450
120 kW	W	590
Line reactors for Smart Line Modules		
5 kW	W	62
10 kW	W	116
16 kW	W	110
36 kW	W	170
55 kW	W	200
Line reactors for Basic Line Modules		
20 kW	W	130
40 kW	W	270
100 kW	W	480

1) Referred to $U_{DC\ link} = 600\ V$

12.12.4 Power loss for power units with internal air cooling

Table 12- 36 Overview of power loss at rated operation for power units with internal air cooling (including electronics losses)

	Unit	Power loss
Active Line Modules		
16 kW	W	282.8
36 kW	W	666
55 kW	W	945.6
80 kW	W	1383.6
120 kW	W	2243.2
Smart Line Modules Booksize		
5 kW	W	79.2
10 kW	W	141.6
16 kW	W	187.8
36 kW	W	406
55 kW	W	665.6
Smart Line Modules Booksize Compact		
16 kW	W	187.8
Basic Line Modules		
20 kW	W	144
40 kW	W	283.6
100 kW	W	628
Single Motor Modules Booksize		
3 A	W	50.4

	Unit	Power loss
5 A	W	73.4
9 A	W	100.4
18 A	W	185.4
30 A	W	309.2
45 A	W	455.2
60 A	W	615.2
85 A	W	786
132 A	W	1270.4
200 A	W	2070.4
Single Motor Modules Booksize Compact		
3 A	W	68 ¹⁾
5 A	W	98 ¹⁾
9 A	W	100.4
18 A	W	185.4
Double Motor Modules Booksize		
2 x 3 A	W	97.6
2 x 5 A	W	132.6
2 x 9 A	W	187.6
2 x 18 A	W	351.2
Double Motor Modules Booksize Compact		
2 x 1.7 A	W	114 ¹⁾
2 x 3 A	W	134 ¹⁾
2 x 5 A	W	194 ¹⁾

¹⁾ Power loss at 8 kHz

12.12.5 Power loss for power units with external air cooling

Table 12- 37 Overview of power loss at rated operation for power units with external air cooling (including electronics losses)

	Unit	Internal Power loss ¹⁾	External power loss	Total power loss
Active Line Modules				
16 kW	W	82.8 (60 + 22.8)	200	282.8
36 kW	W	171 (135 + 36.0)	495	666
55 kW	W	245.6 (200 + 45.6)	700	945.6
80 kW	W	338.6 (305 + 33.6)	1045	1383.6
120 kW	W	533.2 (490 + 43.2)	1710	2243.2

12.12 Power losses of the components

	Unit	Internal Power loss ¹⁾	External power loss	Total power loss
Smart Line Modules				
5 kW	W	41.2 (22 + 19.2)	38	79.2
10 kW	W	66.6 (45 + 21.6)	75	141.6
16 kW	W	64.8 (42 + 22.8)	123	187.8
36 kW	W	116 (80 + 36)	290	406
55 kW	W	185.6 (140 + 45.6)	480	665.6
Single Motor Modules				
3 A	W	35.4 (15 + 20.4)	15	50.4
5 A	W	43.4 (23 + 20.4)	30	73.4
9 A	W	55.4 (35 + 20.4)	45	100.4
18 A	W	95.4 (75 + 20.4)	90	185.4
30 A	W	99.2 (80 + 19.2)	210	309.2
45 A	W	135.2 (110 + 25.2)	320	455.2
60 A	W	160.2 (135 + 25.2)	455	615.2
85 A	W	196 (160 + 36.0)	590	786
132 A	W	270.4 (250 + 20.4)	1000	1270.4
200 A	W	455.4 (435 + 20.4)	1615	2070.4
Double Motor Modules				
2 x 3 A	W	62.6 (35 + 27.6)	35	97.6
2 x 5 A	W	72.6 (45 + 27.6)	60	132.6
2 x 9 A	W	92.6 (65 + 27.6)	95	187.6
2 x 18 A	W	111.2 (80 + 31.2)	240	351.2

¹⁾ Power loss of the power electronics + power loss of the 24 V electronics

12.12.6 Power loss for power units with cold plate

With cold-plate cooling, only part of the power loss remains in the cabinet.
The table below shows the internal and external power loss of the components.

Table 12- 38 Overview of power loss at rated operation for power units with cold plate (including electronics losses)

	Unit	Internal power loss ¹⁾	External power loss	Total power loss
Active Line Modules				
16 kW	W	70.4 (50 + 20.4)	210	280.4
36 kW	W	135.2 (110 + 25.2)	520	655.2
55 kW	W	187.6 (160 + 27.6)	740	927.6
80 kW	W	283.6 (250 + 33.6)	1100	1383.6
120 kW	W	443.2 (400 + 43.2)	1800	2243.2
Smart Line Modules Booksize				
5 kW	W	34.4 (20 + 14.4)	40	74.4
10 kW	W	56.8 (40 + 16.8)	80	136.8

	Unit	Internal power loss ¹⁾	External power loss	Total power loss
Smart Line Modules Booksize Compact				
16 kW	W	56.6 (36.2 + 20.4)	130	186.6
Basic Line Modules				
20 kW	W	46.6 (25 + 21.6)	95	141.6
40 kW	W	71.4 (45 + 26.4)	205	276.4
100 kW	W	168.4 (130 + 38.4)	450	618.4
Single Motor Modules Booksize				
3 A	W	27.6 (12 + 15.6)	18	45.6
5 A	W	35.6 (20 + 15.6)	35	70.6
9 A	W	45.6 (30 + 15.6)	50	95.6
18 A	W	80.6 (65 + 15.6)	100	180.6
30 A	W	85.6 (70 + 15.6)	220	305.6
45 A	W	108 (90 + 18.0)	340	448
60 A	W	128 (110 + 18.0)	480	608
85 A	W	149.2 (130 + 19.2)	620	769.2
132 A	W	220.4 (200 + 20.4)	1050	1270.4
200 A	W	370.4 (350 + 20.4)	1700	2070.4
Single Motor Modules Booksize Compact				
3 A	W	25.6 (10 + 15.6)	40	65.6
5 A	W	30.6 (15 + 15.6)	65	95.6
9 A	W	45.6 (30 + 15.6)	50	95.6
18 A	W	80.6 (65 + 15.6)	100	180.6
Double Motor Modules Booksize				
2 x 3 A	W	55.6 (34 + 21.6)	36	91.6
2 x 5 A	W	61.6 (40 + 21.6)	65	126.6
2 x 9 A	W	81.6 (60 + 21.6)	100	181.6
2 x 18 A	W	95.2 (70 + 25.2)	250	345.2
Double Motor Modules Booksize Compact				
2 x 1.7 A	W	42 (20.4 + 21.6)	72	114
2 x 3 A	W	44 (22.4 + 21.6)	90	134
2 x 5 A	W	59 (37.4 + 21.6)	135	194

1) Power loss of the power electronics + power loss of the 24 V electronics

Note

Lower average power losses are obtained for intermittent duty.

12.12.7 Power loss for liquid-cooled power units

Table 12- 39 Overview of power loss during rated operation for liquid-cooled power units (including electronics losses)

	Unit	Internal power loss ¹⁾	External power loss	Total power loss
Active Line Modules				
120 kW	W	443.2 (400 + 43.2)	1800	2243.2
Single Motor Modules				
200 A	W	370.4 (350 + 20.4)	1700	2070.4

¹⁾ Power loss of the power electronics + power loss of the 24 V electronics

12.12.8 Electronics losses of power units

Table 12- 40 Electronics losses for power units with internal/external air cooling

Component		Internal/external air cooling Power loss [W]
Single Motor Modules	3 A	20.4
	5 A	20.4
	9 A	20.4
	18 A	20.4
	30 A	19.2
	45 A	25.2
	60 A	25.2
	85 A	36.0
	132 A	20.4
	200 A	20.4
Single Motor Modules Booksize Compact	3 A	20.4
	5 A	20.4
	9 A	20.4
	18 A	20.4
Double Motor Modules	2 x 3 A	27.6
	2 x 5 A	27.6
	2 x 9 A	27.6
	2 x 18 A	31.2
Double Motor Modules Booksize Compact	2 x 1.7 A	27.6
	2 x 3 A	27.6
	2 x 5 A	27.6
Active Line Modules	16 kW	22.8
	36 kW	36.0
	55 kW	45.6
	80 kW	33.6

Component		Internal/external air cooling Power loss [W]
	120 kW	43.2
Basic Line Modules	20 kW	24
	40 kW	33.6
	100 kW	48
Smart Line Module	5 kW	19.2
	10 kW	21.6
	16 kW	22.8
	36 kW	36.0
	55 kW	45.6
Smart Line Module Booksize Compact	16 kW	22.8

Table 12- 41 Electronics losses for power units with cold plate

Component		Cold plate Power loss [W]
Motor Modules Booksize	3 A	15.6
	5 A	15.6
	9 A	15.6
	18 A	15.6
	30 A	15.6
	45 A	18.0
	60 A	18.0
	85 A	19.2
	132 A	20.4
	200 A	20.4
	2 x 3 A	21.6
	2 x 5 A	21.6
	2 x 9 A	21.6
	2 x 18 A	25.2
Motor Modules Booksize Compact	3 A	15.6
	5 A	15.6
	9 A	15.6
	18 A	15.6
	2 x 1.7 A	21.6
	2 x 3 A	21.6
	2 x 5 A	21.6
Active Line Modules	16 kW	20.4
	36 kW	25.2
	55 kW	27.6
	80 kW	33.6
	120 kW	43.2

Component		Cold plate Power loss [W]
Smart Line Module Booksize	5 kW	14.4
	10 kW	16.8
Smart Line Module Booksize Compact	16 kW	20.4
Basic Line Modules	20 kW	21.6
	40 kW	26.4
	100 kW	38.4

Table 12- 42 Electronics losses for liquid-cooled power units

Component		Liquid cooled Power loss [W]
Motor Module	200 A	20.4
Active Line Module	120 kW	43.2

12.12.9 Maximum power losses in the partial load range

Losses in the partial load range for Line Modules and Motor Modules

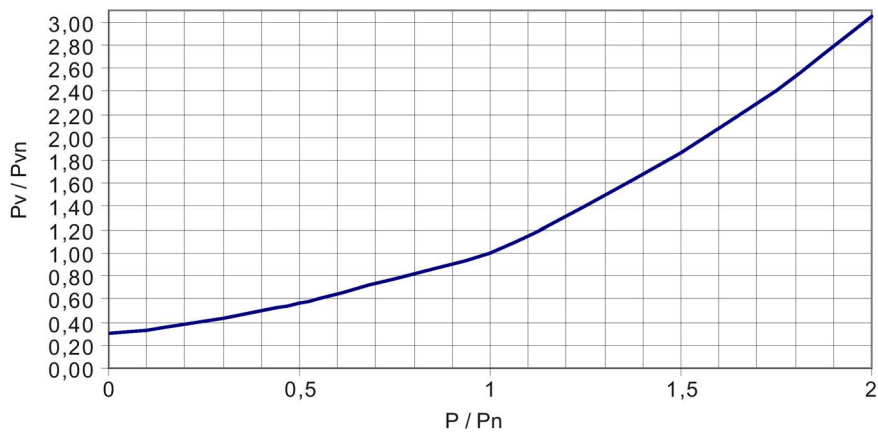

Figure 12-49 Losses in the partial load range for Active Line Modules and Smart Line Modules

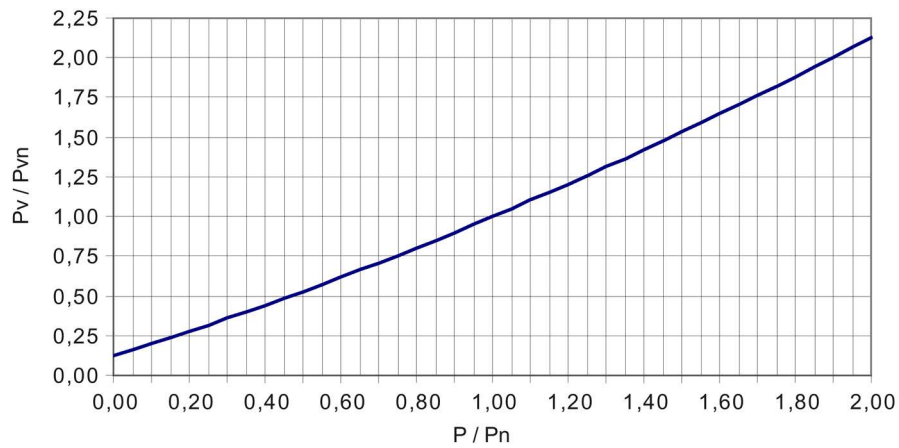

Figure 12-50 Losses in the partial load range for Basic Line Modules

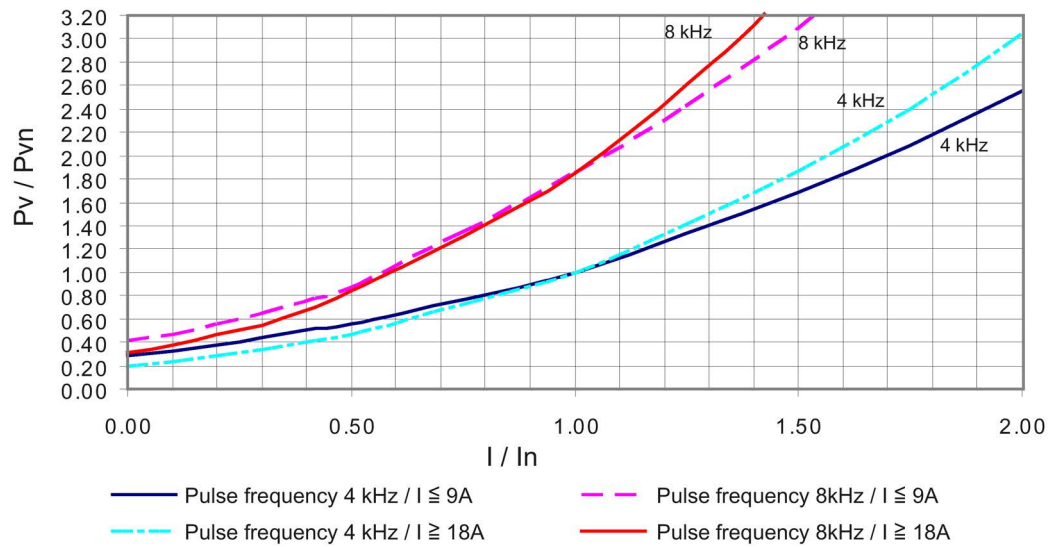

Figure 12-51 Losses in the partial load range for Motor Modules

Losses in the partial load range for line reactors and Active Interface Modules

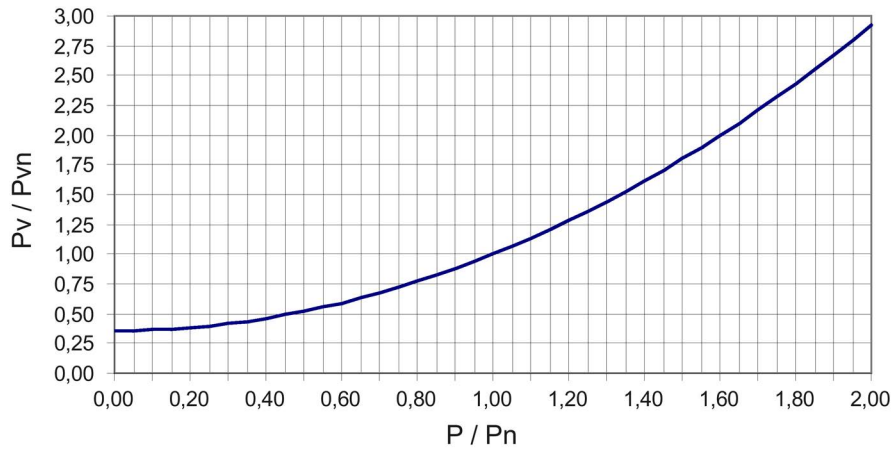

Figure 12-52 Losses in the partial load range for Active Interface Modules

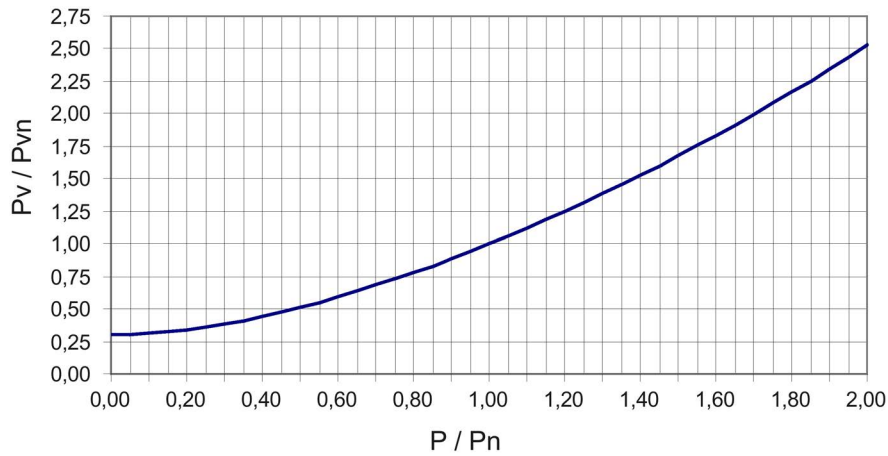

Figure 12-53 Losses in the partial load range for line reactors for Smart Line Modules

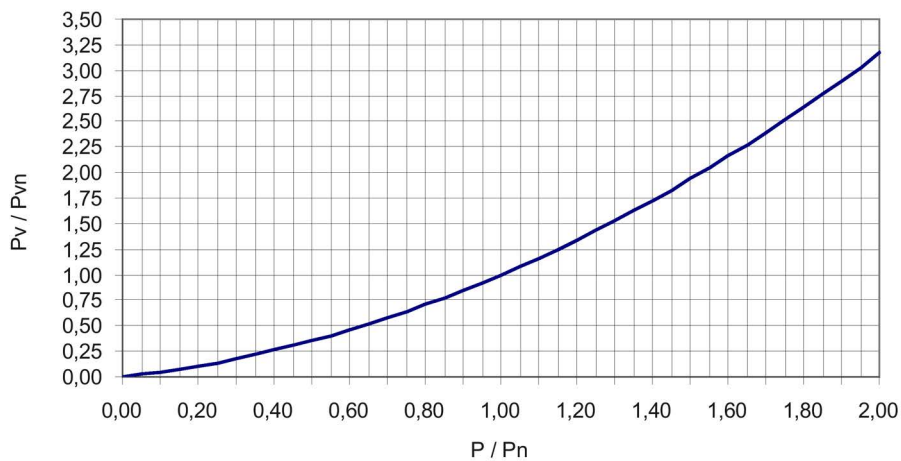

Figure 12-54 Losses in the partial load range for line reactors for Basic Line Modules

12.12.10 Typical power losses for Motor Modules

The information on the power losses in the previous chapters are maximum values, which occur in the most unfavorable case. For typical applications, the losses are lower.

The following applies as typical application:

- Maximum motor cable length, 30 m
- 4 kHz pulse frequency
- DC-link voltage 540 V - 600 V

The power loss for typical applications can be calculated using the following formula:

$$P_V [W] = a + S_1 \cdot (I_1 + I_2) + S_2 \cdot (I_1^2 + I_2^2)$$

- a Electronics losses of the Motor Module
- S₁, S₂ Coefficients to calculate power loss
- I₁ Current (arithmetic mean value) of the 1st axis
- I₂ Current (arithmetic mean value) of the 2nd axis

Overview of required coefficients

Table 12- 43 Coefficients to calculate the power loss in the control cabinet for internally cooled Motor Modules for typical applications

Motor Module	a [W]	S ₁ [W/A]	S ₂ [W/A ²]
Single Motor Module 3 A	14	3.29	0.205
Single Motor Module 5 A	14	3.29	0.205
Single Motor Module 9 A	14	3.29	0.205
Single Motor Module 18 A	14	3.29	0.205
Single Motor Module 30 A	20	4.71	0.113
Single Motor Module 45 A	25	5.50	0.054
Single Motor Module 60 A	25	5.50	0.054
Single Motor Module 85 A	36	6.11	0.030
Single Motor Module 132 A	150	6.01	0.018
Single Motor Module 200 A	150	6.01	0.017
Double Motor Module 2 x 3 A	19	5.20	0.200
Double Motor Module 2 x 5 A	19	5.20	0.200
Double Motor Module 2 x 9 A	19	5.18	0.247
Double Motor Module 2 x 18 A	22	5.57	0.091

Table 12- 44 Coefficients to calculate the power loss in the control cabinet for externally cooled Motor Modules for typical applications

Motor Module	a [W]	S ₁ [W/A]	S ₂ [W/A ²]
Single Motor Module 3 A	10	2.30	0.100
Single Motor Module 5 A	10	2.30	0.100
Single Motor Module 9 A	10	2.30	0.100
Single Motor Module 18 A	10	2.34	0.101
Single Motor Module 30 A	16	1.29	0.057
Single Motor Module 45 A	21	1.31	0.015
Single Motor Module 60 A	27	1.37	0.006
Single Motor Module 85 A	32	1.37	0.006
Single Motor Module 132 A	50	1.06	0.004
Single Motor Module 200 A	50	1.06	0.004
Double Motor Module 2 x 3 A	15	1.37	0.240
Double Motor Module 2 x 5 A	15	1.37	0.240
Double Motor Module 2 x 9 A	15	1.37	0.240
Double Motor Module 2 x 18 A	18	1.56	0.056

Overview of typical power losses at the rated operating point

Table 12- 45 Typical power losses in the control cabinet for operation at the rated operating point for internally and externally cooled Motor Modules

Motor Module	P_{Vn} [W] internal air cooling	P_{Vn} [W] external air cooling
Single Motor Module 3 A	26	18
Single Motor Module 5 A	36	24
Single Motor Module 9 A	60	39
Single Motor Module 18 A	140	85
Single Motor Module 30 A	263	106
Single Motor Module 45 A	382	110
Single Motor Module 60 A	550	130
Single Motor Module 85 A	772	192
Single Motor Module 132 A	1257	260
Single Motor Module 200 A	2032	422
Double Motor Module 2 x 3 A	54	28
Double Motor Module 2 x 5 A	81	41
Double Motor Module 2 x 9 A	152	79
Double Motor Module 2 x 18 A	281	110

Cooling circuit and coolant properties

13.1 Cooling circuit requirements

13.1.1 Technical cooling circuits

Technical cooling circuits can be divided into three systems:

- **Closed cooling circuits (recommended)**

In closed systems, the circuit coolant is separated from the surrounding atmosphere, which prevents the ingress of oxygen. The coolant is only routed through SINAMICS devices, the components required for cooling and, if necessary, a motor. The heat is dissipated to the atmosphere indirectly by means of heat exchangers. The system should ideally function without losing any coolant and, once filled, should not need any water to be added. The composition of the coolant can be adjusted as required (e.g. by using desalinated water and adding anti-corrosion agents). It either does not change at all during operation, or changes only in a defined manner.

The closed cooling circuit is recommended as a standard solution.

- **Open cooling circuit**

The coolant is routed not only through the SINAMICS devices and components required for cooling, but also through external devices.

The heat transferred to the circuit coolant evaporates via a cooling tower. This evaporation causes the coolant to become more concentrated (densification) because water molecules escape, while dissolved substances remain in the coolant. During operation, therefore, the composition of the coolant changes significantly, which means that it must be monitored and topped up continuously.

- **Semi-open circuit**

Oxygen can only enter the cooling system through the pressure equalization tank, otherwise the same as a "closed cooling circuit". The semi-open cooling circuit is permissible.

13.1.2 Cooling system requirements

Open cooling systems must never be used for liquid-cooled power units. A closed cooling circuit with a membrane expansion tank, safety valve, and heat exchanger is recommended, which connects the cooling circuit to an external cooler (refer also to Chapter Using heat exchangers (Page 762)).

Requirements

- A particle filter (particle size < 100 µm) must be installed in the cooling circuit to prevent foreign particles from being washed in.
- Mixed installations should be avoided wherever possible.
- The permissible pressures in the cooling system must be observed.
- Cavitation must be prevented in the cooling system.
- Equipotential bonding must be provided between the components in the cooling system.
- The customer must take measures to protect the devices against condensation.
- An anti-corrosion agent and, if necessary, a biocide should be mixed into the coolant.
- If there is a risk of frost, preventive measures must be taken during operation, storage, and transportation (e.g. emptying and blowing out with air, additional heating).
- The requirements of the coolant in terms of its properties (temperature, chemical characteristics, etc.) must be observed.

Recommendations

- To ensure mechanical decoupling, the devices should be connected by means of hoses.
- To prevent blockages and corrosion, you are advised to install a flushback filter in the circuit (so that residues can be rinsed out when the system is running).
- The power units should be connected to the cooling circuit by means of shut-off fittings so that they can be disconnected from the cooling circuit for servicing or repair without having to empty the entire cooling system. A cooling water hose (EPDM) can be used to connect the shut-off fitting to the power unit.

NOTICE

Bursting of the heatsink if the coolant connections are kept closed

As long as there is still coolant in the device, the heatsink can burst if the coolant connections are kept closed. This is because an inadmissibly high pressure can be generated when the coolant expands as the temperature increases.

- Do not close the coolant connections if cooling liquid is still present in the device.

13.1.3 Cooling circuit configuration

The liquid-cooled power units are designed to be connected in parallel to the cooling circuit. The pressure drop in the joint supply and return lines is to be kept at negligible levels by choosing a sufficiently large pipe diameter. The intake has differential pressure p with respect to the return. This pressure is usually generated by a pump.

The pressure of a pump depends on the flow rate. Therefore, depending on the number of connected components, a different pressure is obtained. At the minimum differential pressure p_1 (measured between the supply and return lines of the individual component), the volume of coolant required to enable the component to achieve its rated power or rated current is to flow through each component. At the maximum differential pressure p_2 (measured between the supply and return lines of the individual component), the volumetric flow must not result in damage to the component, for example, by means of cavitation. If necessary, pressure reducing valves such as baffle plates will have to be installed in the piping; these must be easy to access, clean, and/or replace.

When the pump is switched off, static pressure occurs in the system. The static pressure can be influenced by the primary pressure of the membrane expansion tank and should be at least 30 kPa on the pump's suction side. If the static pressure is too low, there is the risk that the pump will be damaged by cavitation when operational. Otherwise, minimum pressure values different than those specified by the pump manufacturer must be observed. When components are installed at different heights, the geodesic pressure caused by the height difference must be taken into account (1 m height difference corresponds to 10 kPa).

When the pump is switched on, a (location-dependent) flow pressure is present in the cooling circuit, which must be determined from the pump characteristic curve and the volume-flow-dependent pressure drop. The pressure drop in the filter and, if applicable, an additional pressure drop in the connection pipes must be added to the pressure drop of the liquid-cooled power units (70 kPa for H₂O). Up to 50 kPa must be added for the pressure drop in a (contaminated) filter and in connection pipes. The intersection of the pump characteristic curve and the pressure drop of the whole cooling system yields the volumetric flow V_{rated} of the coolant at this operating point.

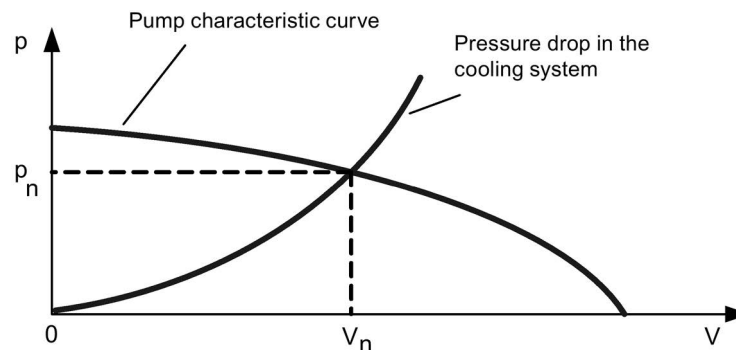

Figure 13-1 Pump characteristic curve

Permissible system pressure

The maximum permissible system pressure is 600 kPa. If a pump that is capable of exceeding this maximum permissible system pressure is used, the customer must take steps (e.g. safety valve $p \leq 600$ kPa, pressure control, or similar) to ensure that the maximum pressure limit is not exceeded.

Permissible pressure difference

The maximum permissible pressure difference for a heat sink is 200 kPa. Higher pressure differences significantly increase the risk of cavitation and abrasion. The lowest possible differential pressure between the coolant in the supply and return lines should be selected to allow pumps with a flat characteristic to be used.

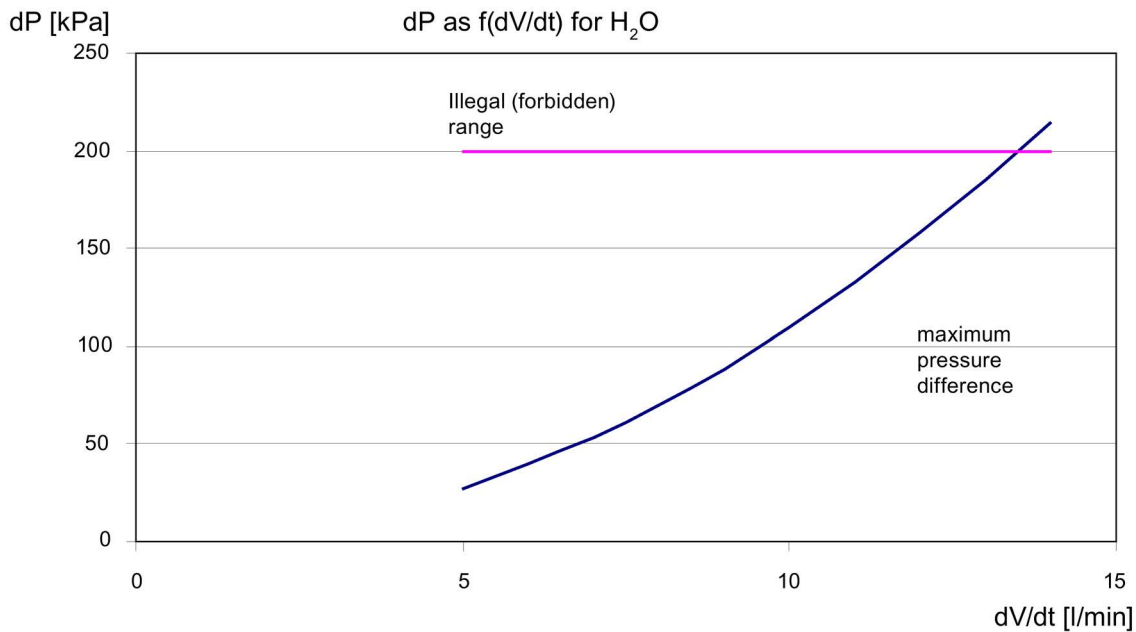

Figure 13-2 Pressure difference as a function of volumetric flow

Pressure difference and pressure drop when using coolant mixtures

If a mixture of Antifrogen N and H₂O is used as a coolant, the rated pressure must be calculated according to the mixing ratio. The following table specifies the pressure drop across components at different coolant temperatures for a coolant with mixing ratio 45 % Antifrogen N.

Table 13- 1 Pressure drop at different coolant temperatures for Antifrogen N/H₂O: 45 %

dV/dt H ₂ O [l/min]	dP H ₂ O [kPa]	dP Antifrogen N 0 °C [kPa]	dP Antifrogen N 20 °C [kPa]	dP Antifrogen N 45 °C [kPa]	dP Antifrogen N 50 °C [kPa]
8	70	121	97	81	78

The characteristic curves for the pressure drop across the heatsinks as a function of volumetric flow vary depending on the temperature and the Antifrogen N / water coolant mix.

dp as dV/dt for various coolants

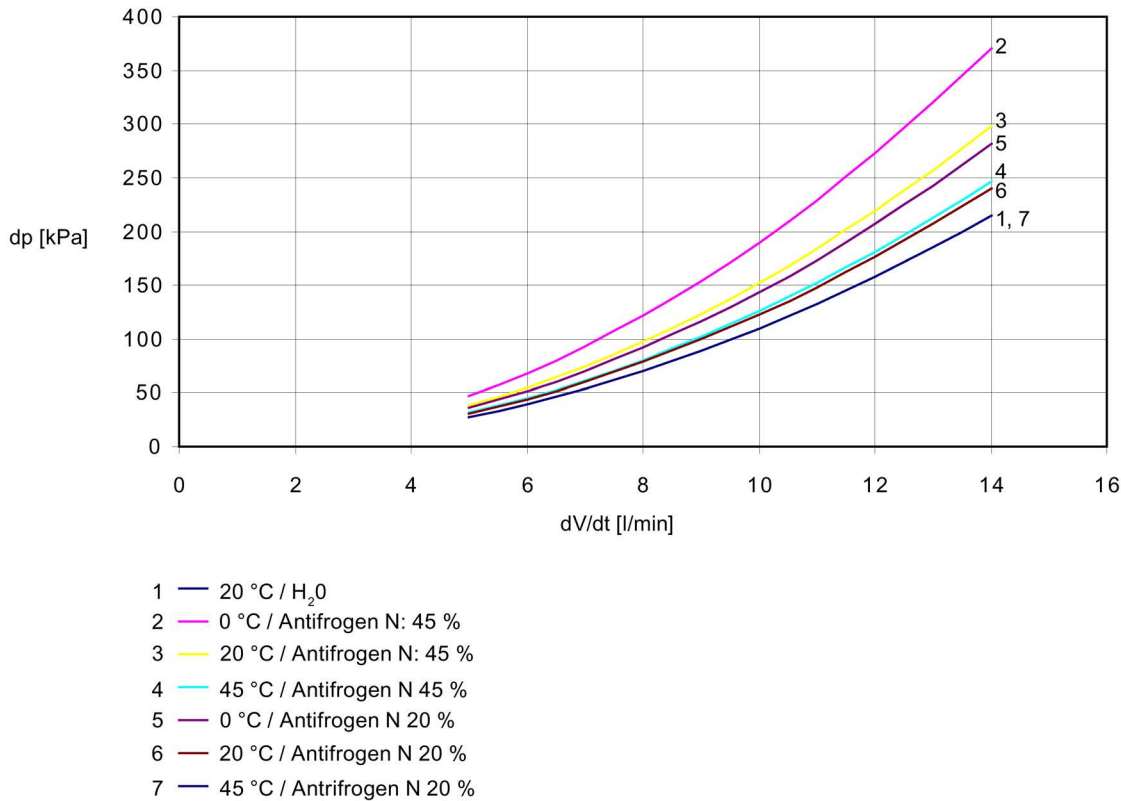

Figure 13-3 Pressure difference as a function of volumetric flow

Operating pressure

The **operating pressure** must be set according to the flow conditions in the supply and return lines of the cooling circuit. The required coolant flow rate per time unit must be set according to the technical data of the components. The components are normalized to a rated pressure of 70 kPa (for coolant type H₂O) via a baffle plate.

Layout of the components

The components should be arranged in the system in such a way that the overall length of the supply and discharge lines is the same for every SINAMICS component.

Water cooling systems with series-connected SINAMICS devices are not permitted.

Dimensioning the cooling circuit

Recommendation for dimensioning the cooling circuit:

The differential pressure between the supply and return lines should be selected so that:

$$\sum dP_i < dP_{\text{Syst}} < \sum dP_i + 30 \text{ kPa}$$

The individual pressure drops P_i represent the pressure drops of components (heat exchanger, piping, 70 kPa for the SINAMICS devices connected in parallel, valves, dirt traps, pipe bends, etc.).

Coolant pipes must be routed with extreme care. The pipes must never come into contact with electrically live components; an insulation clearance of $> 13 \text{ mm}$ must always be left between pipes and live parts! The pipes must be securely mounted and checked for leaks.

13.1.4 Installation

A closed stainless-steel cooling circuit, preferably combined with monitoring of the coolant quality, is strongly recommended to ensure the longest possible service life for the heat sink.

NOTICE
Damage caused by incorrectly routed coolant lines
Leaking coolant can cause a short circuit.
<ul style="list-style-type: none">• Route the coolant pipes very carefully.• Fix the pipes securely and check them for leaks.• Ensure that the pipes never come into contact with live components.

Materials and connections

Stainless-steel pipes are used to route the coolant through the cooling plates on the liquid-cooled power units. For power units with cold plate, the coolant is routed by means of integrated channels in the aluminum cold plate.

To minimize the electrochemical processes taking place in the cooling system, the materials must be coordinated with one another accordingly. Mixed installations, i.e. a combination of different materials, such as copper, brass, iron, or halogenated plastic (PVC hoses and seals), should therefore be avoided or limited to the absolutely essential minimum.

The valves and connections required in the cooling system must be made of stainless steel (V2A or V4A steel; NIROSTA austenite).

The following materials can be used for the cooling system piping:

- Pipes and corrugated piping made of stainless steel (V2A or V4A steel; NIROSTA austenite)
- Hoses made of EPDM / EPDM with an electrical resistance $<10^9$ ohms (e.g. Semperflex FKD; from the Semperit company, Wimpassing - Austria)
- DEMITEL® hoses made of PE / EPDM (the Telle company, Nuremberg)
- Clamps according to DIN 2871 for fixing, available for example from the Telle company

All control cabinets must be designed with a PE busbar and a good electrical connection must be established between them.

Note

The sealing materials must be free of chlorides, graphite, and carbon (Viton® or EPDM).
Teflon-based seals are not permitted.

Note

When non-conductive hoses are used, particular attention must be paid to the equipotential bonding of all the components (see Chapter Equipotential bonding in the cooling system (Page 762)).

Note

- Check the cooling system for tightness after installation.
-

13.1.5 Preventing cavitation

The following applies to all cooling circuits:

- The cooling circuit must always be designed in such a way that the pressure compensator is located on the suction side of the pump (if possible, directly at the pump).
- The minimum pressure on the suction side of the pump must be approximately 30 kPa, or the geodesic height from the reservoir to the pump suction side must be > 3 m.
- The pressure drop across a SINAMICS device must not exceed 200 kPa in continuous operation, otherwise the high volumetric flow can increase the risk of cavitation and/or abrasion damage.
- The guidelines given in Chapter Cooling circuit configuration (Page 751) regarding series connections and maximum pressure must also be followed.

13.1.6 Commissioning



 WARNING
Electric shock due leaking coolant
Death or serious injury can result when coolant is touched that is at a specific voltage (i.e. is live).
<ul style="list-style-type: none">• Before venting, switch the plant or system into a no-voltage condition.

When commissioning the cooling water circuit, the following sequence must be observed:

1. Ventilate the heat sink the first time the devices are filled.
2. Remove the fixing glands located in front of the vent valve.
3. Perform ventilation.
4. Close the vent valve.
5. Screw the fixing glands tight again.
6. Check the seals.
7. Set the operating pressure according to the flow conditions of the cooling water system in the supply and return lines.
8. Set the required cooling water flow rate per time unit.

13.2 Coolant requirements

13.2.1 Coolant properties

Properties of the cooling medium

Water or a water/anti-freeze mixture that meets the relevant requirements can be used as a cooling medium. The cooling medium must be chemically neutral, clean, and not contain any solids.

The cooling water must fulfill the following requirements over the long term:

Table 13- 2 Cooling water specifications

		Liquid Cooled
Properties		Chemically neutral, clean, free of solids
Max. inlet temperature (in operation)	°C	45 (55 with derating)
Max. coolant temperature	°C	55
Operating pressure	kPa	100 ... 600
System pressure (with respect to the atmosphere)	kPa	600
Test pressure (with respect to the atmosphere)	kPa	1200
Minimum differential pressure p1	kPa	70
Nominal differential pressure p _n	kPa	100
Maximum differential pressure p2	kPa	200
Flow rate	l/min	5 ... 8
Max. size of any particles in the coolant	mm	0.1
pH value		6.5 ... 9
Chloride	ppm	< 200
Sulfate	ppm	< 240
Nitrate	ppm	< 50
Dissolved solids	ppm	< 340
Total hardness	ppm	< 170
Electrical conductivity	μS/cm	< 2000

NOTICE

Component damage caused by condensation

Condensation on the components can result in their failure.

- Appropriately control the cooling water temperature.

13.2 Coolant requirements

NOTICE
Cooling circuit damage caused by seawater The heat sink material is damaged by seawater. <ul style="list-style-type: none">• Do not use seawater as coolant.

Note

As a general rule, tap water is not suitable for use in the cooling circuit, although it can be mixed with de-ionized water. Losses must always be replenished with de-ionized water.

Note

The flow created when the heat sinks are filled results in automatic ventilation, so there is no need for the devices to be ventilated separately.

The coolant should be checked 3 months after the cooling circuit is filled for the first time and, subsequently, once a year. If the cooling water becomes cloudy, is colored, or becomes contaminated by germs, the cooling circuit must be cleaned and refilled.

An inspection glass should be provided in the cooling circuit to make it easier to check the cooling water.

13.2.2 Corrosion Inhibitor Additive (Inhibiting)

Nalco 00GE056 (Nalco company) is recommended as anti-corrosion agent. The concentration of anti-corrosion agent in the cooling water must be at least 2500 ppm (250 ml/100 liters cooling water).

The water quality must correspond to Chapter Coolant properties (Page 757), or the water used must be de-ionized.

Note

Corrosion inhibitor does not need to be added if the anti-freeze Antifrogen N is used in the right concentration (see Chapter Anti-Freeze Additive (Page 759)).

13.2.3 Anti-Freeze Additive

Antifrogen N (from Clariant) is recommended as antifreeze. The percentage of antifreeze must be between 20% and 45%. This ensures frost protection down to a temperature of at least -10 °C.

NOTICE

Damage caused by overheating when using antifreeze

The cooling system no longer functions if an excessively high percentage of antifreeze is used.

- The maximum percentage of antifreeze must not exceed 45%.



⚠ WARNING

Electric shock resulting from leaks in the cooling system

Cooling water mixtures with Antifrogen N are highly conductive. If the insulation does not function, this will result in death or severe injury if you come into contact with it.

- After a coolant leak, clean the insulation system.

NOTICE

Damage to EPDM hoses as a result of additives containing oil

EPDM is destroyed by anticorrosion agents.

- When using EPDM hoses, do not use oily anticorrosion agents.

Note

Adapting the pump power

The kinematic viscosity of the cooling water is changed when adding antifreeze.

- Correspondingly adapt the pump power.

13.2.4 Biocide additives (only if required)

Closed cooling circuits with soft water ($^{\circ}\text{DH} > 4$) are susceptible to microbes. The risk of corrosion caused by microbes is virtually non-existent in chlorinated drinking water systems.

If Antifrogen N antifreeze is used with a concentration of 20% or higher, it can be assumed that there is an adequate biocide effect.

The following types of bacteria are encountered in practice:

- Bacteria that cause the formation of slime
- Corrosive bacteria
- Bacteria that cause deposits of iron

The type of bacteria determines the suitability of a biocide. A water analysis must be carried out once a year to determine the number of bacterial colonies. Suitable biocides are available, for example, from Nalco.

Recommendation

Twice a month Nalco N 77352 is added intermittently. The dosing quantity is 5 to 15 mg/100 liters of cooling water. This product has no adverse effect on Nalco 00GE056 corrosion inhibitor.

Note

The type of bacteria determines the biocide.

The manufacturer's recommendations must be followed regarding the dosage and compatibility with any inhibitor used.

It is not permissible that biocides and Antifrogen N are mixed.

13.3 Anti-condensation measures

The customer must take measures to protect the devices against condensation.

Condensation occurs when the inlet temperature of the cooling medium is significantly lower than room temperature (ambient temperature). The permissible temperature difference between coolant and air varies as a function of the relative humidity Φ of the ambient air. The air temperature at which the aqueous phase precipitates is referred to as the "dew point".

The table below shows the dew points (in °C) for an atmospheric pressure of 100 kPa (\approx installation altitude, 0 to 500 m). If the temperature of the coolant is below the specified value, condensation may occur (i.e. the coolant temperature must always be higher than the dew point temperature).

Table 13-3 Dew point temperature as a function of the relative air humidity (Φ) and the room temperature at an installation altitude of between 0 and 500 m

T _{room} [°C]	Dew point temperature in °C at a relative humidity Φ in %										
	20 %	30%	40%	50%	60%	70%	80%	85%	90%	95%	100 %
10	< 0	< 0	< 0	0.2	2.7	4.8	6.7	7.6	8.4	9.2	10
20	< 0	2	6	9.3	12	14.3	16.4	17.4	18.3	19.1	20
25	0.6	6.3	10.5	13.8	16.7	19.1	21.2	22.2	23.2	24.1	25
30	4.7	10.5	14.9	18.4	21.3	23.8	26.1	27.1	28.1	29.1	30
35	8.7	14.8	19.3	22.9	26.1	28.6	30.9	32.1	33.1	34.1	35
38	11.1	17.4	22	25.7	28.8	31.5	33.8	34.9	36.1	36.9	38
40	12.8	19.1	23.7	27.5	30.6	33.4	35.8	36.9	37.9	38.9	40
45	16.8	23.3	28.2	32.1	35.3	38.1	40.6	41.8	42.9	43.9	45
50	20.8	27.5	32.6	36.6	40.1	42.9	45.5	46.6	47.8	48.9	50
55	24.9	31.9	37.1	41.2	44.7	47.7	50.4	51.7	52.8	53.9	55

The dew point also depends on the absolute pressure (i.e. the installation altitude).

The dew points for lower atmospheric pressures lie below the dew points for a height of 0 m. Therefore, selecting the coolant intake temperature for a height 0 m always sufficient.

Various measures can be taken to prevent condensation:

- Temperature-controlled valves in the supply line.
In the cooling circuit, a temperature-controlled valve must be provided in the supply line.
- Closed-loop water temperature control
The water temperature is controlled depending on the room temperature. This is the preferred method with high room Φ temperatures, low water temperatures, and high air humidity.
- Physical dehumidification.
A physical dehumidification is only effective in closed spaces. This method involves condensing the air humidity in an air-to-water heat exchanger, which is continuously operated using the cold cooling water.
- Installing a heater with a sufficient power rating in the cabinet.

To prevent condensation, a humidity detector can be used to monitor the air humidity. The humidity detector is not included in the scope of delivery.

13.4 Equipotential bonding in the cooling system

Equipotential bonding between the components in the cooling system is required (SINAMICS S120, heat exchanger, piping, pump, etc.). This must be effected using a copper bar or stranded copper with the appropriate conductor cross-sections to prevent the electrochemical processes.

All cabinets must be bolted together in such a way as to ensure good conductivity (e.g. cabinet beams directly connected to ensure a good electrical connection) to prevent potential differences and, in turn, avoid the risk of electrochemical corrosion. As a consequence, a PE bar must also be installed in all the cabinets, including the cooling system.

13.5 Using heat exchangers

13.5.1 Water-to-water heat exchanger

If a cooling circuit that does not exceed 35 °C but does not fulfill the cooling water requirements is already installed in the system, the two cooling circuits can be linked via a water-to-water heat exchanger.

The coolers for the Line Modules are attached via a distributor in such a way as to ensure the required flow rate without exceeding the maximum permissible pressure. Conditions, such as height differences and distances, must be taken into account here.

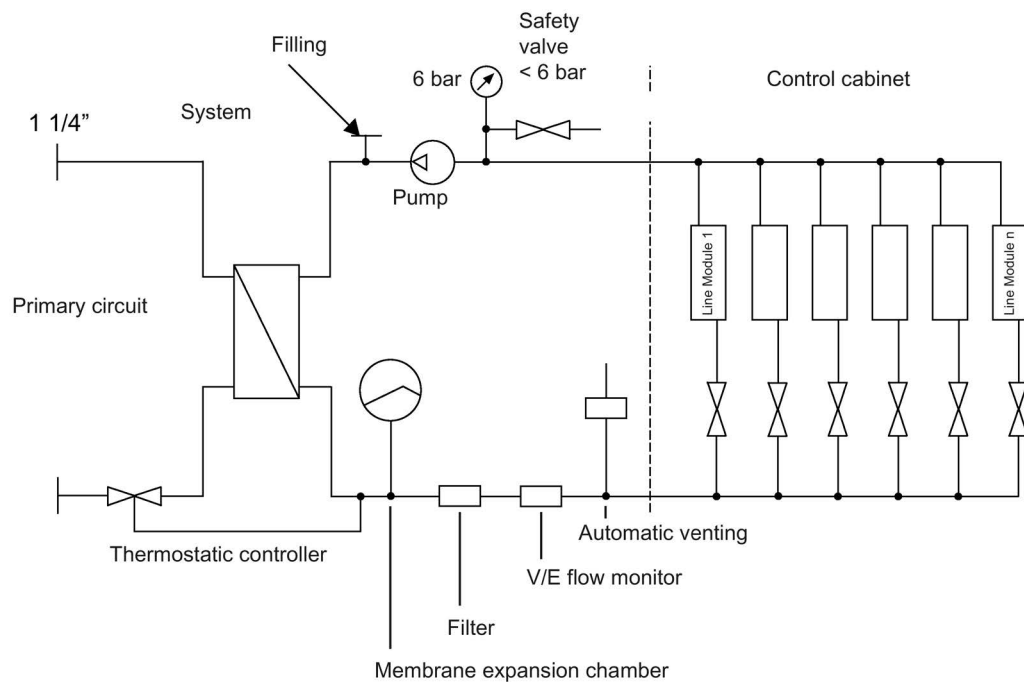

Figure 13-4 Water-to-water heat exchanger

13.5.2 Air-to-water heat exchanger

If no process water is available, but it is nonetheless best to use water-cooled Line Modules, an air-to-water cooling system can be used. The temperature of the ambient air must not be excessively high, e.g. $> 35^{\circ}\text{C}$ (in accordance with the technical data for the air-to-water heat exchanger).

During setup, you must ensure that a primary air cooling circuit and not a process water circuit is installed.

Measures to prevent excessive cooling must only be taken on the secondary side by means of closed-loop temperature control involving a thermostat or a solenoid valve.

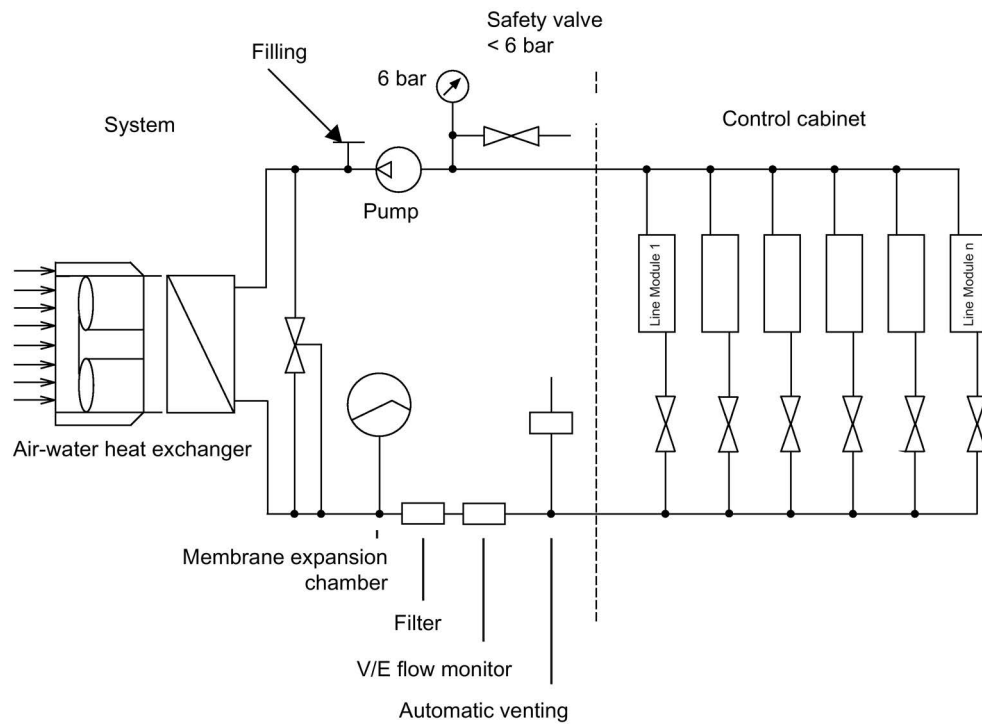

Figure 13-5 Air-to-water heat exchanger

13.5.3 Active cooling unit

If no process water is available and the ambient air is $> 35\text{ }^{\circ}\text{C}$ ($35\text{ }^{\circ}\text{C} < \tau < 40\text{ }^{\circ}\text{C}$), an active cooling unit can be used. This unit works in the same way as a refrigerator.

The following diagram shows the configuration of the cooling circuit in respect of Line Modules.

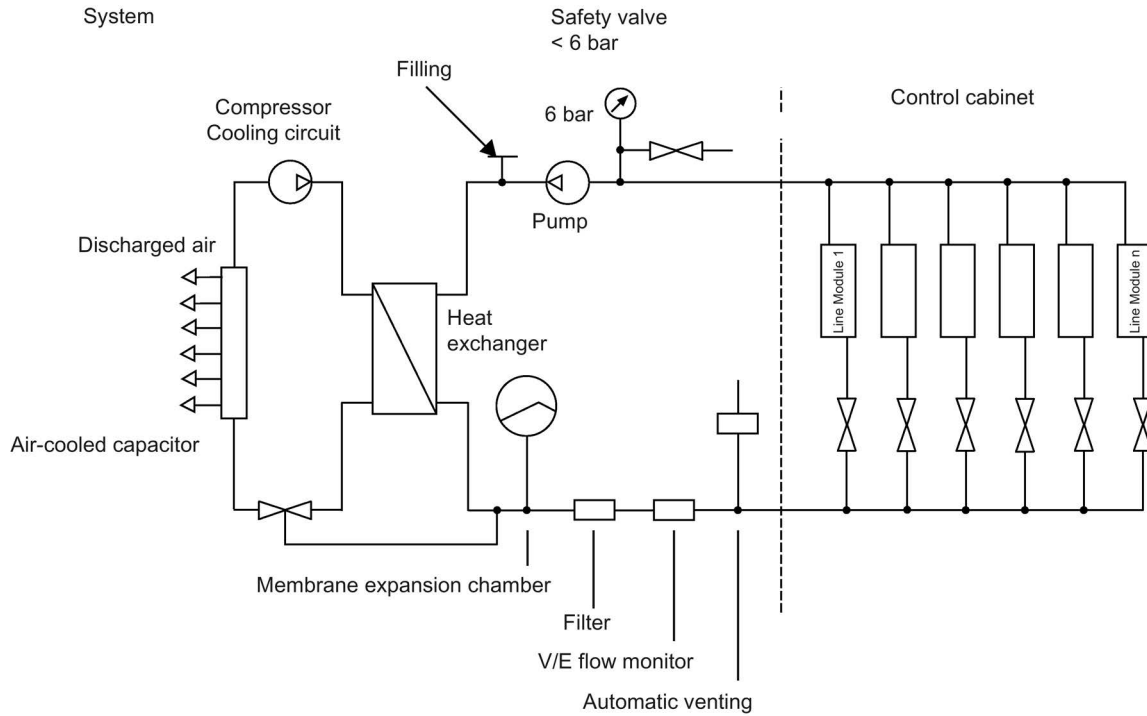

Figure 13-6 Active cooling unit

14.1 Spare parts

You can find spare parts in the Internet here (<https://www.sow.siemens.com>).

14.2 Replacing the fan

14.2.1 Safety instructions when replacing a fan

**! WARNING****Electric shock when live parts are touched**

Before replacing the fan, you must switch off the power supplies (400 VAC and 24 V DC). A hazardous voltage is still present for up to five minutes after the power supply has been switched off.

Contact with live parts can result in death or serious injury.

- Remove the device cover or the fan cover only after a certain time.
- Check for zero voltage before removing the component.

Note

When replacing the fan, you must observe the ESD regulations.

Only qualified personnel are permitted to install spare parts.

14.2.2 Replacing the fan for components with internal and external air cooling

Replacing the fan for components, sizes 50 to 200 mm

Table 14- 1 Removing the fan







Size 50 mm	Size 100 mm	Sizes 150 mm and 200 mm
		
<p>1. Remove the module from the drive line-up. 2. Release the catches to open the fan cover.</p>		
		
<p>3. Release and withdraw the connector (1). 4. Release the catch (2) and remove the fan.</p>		
		

Table 14-2 Installing a fan

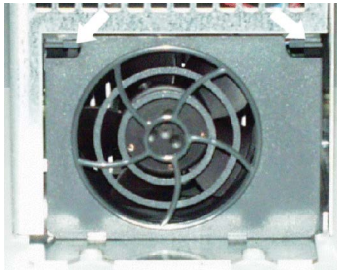
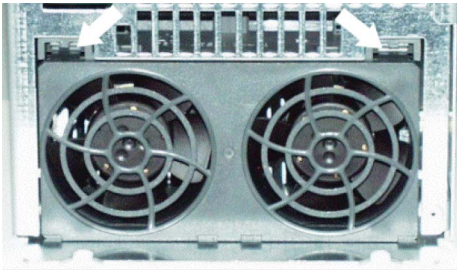
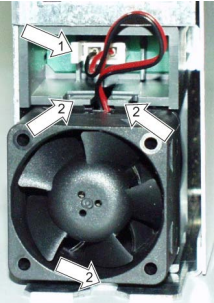
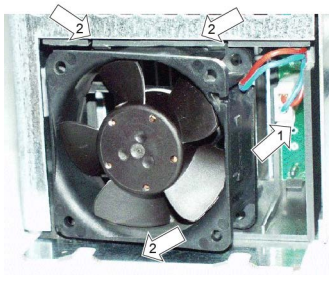
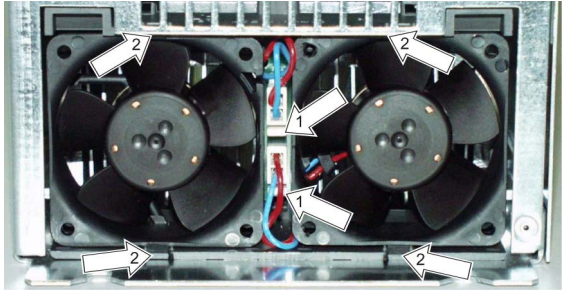
Size 50 mm	Size 100 mm	Sizes 150 mm and 200 mm
		
<ol style="list-style-type: none">1. Before installing the fan, please note the airflow direction. The arrow on the fan must point toward the cooling ribs.2. Push the fan into a position where it is completely latched. When doing this, do not crush the connecting cables!3. Insert the connector until it latches into place.4. Attach the fan cover.		

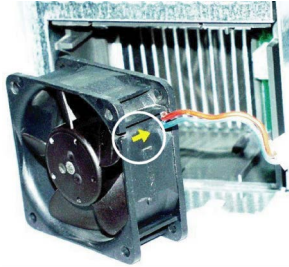
Note

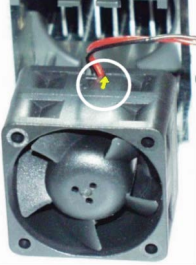
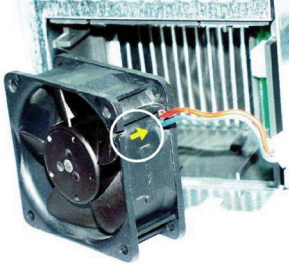

The spare parts pack for components sized 150 mm and 200 mm contains two different fan covers:

- One fan cover for components with internal air cooling
- One fan cover for components with external air cooling

Make sure you use the right fan cover!

14.2 Replacing the fan

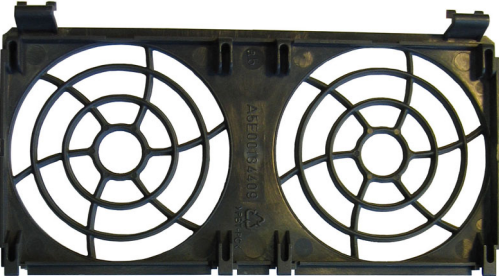
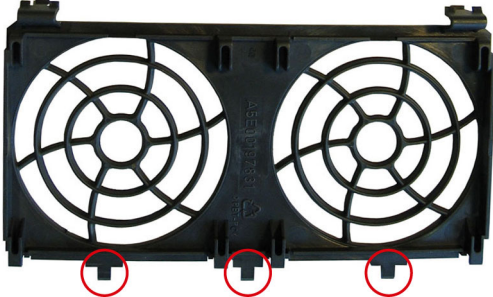
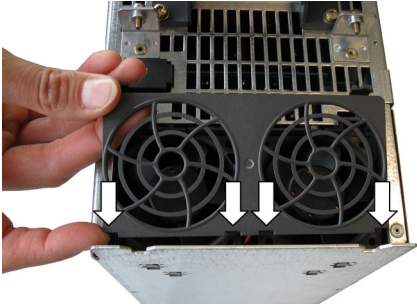
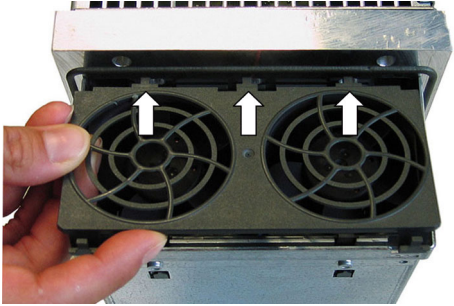
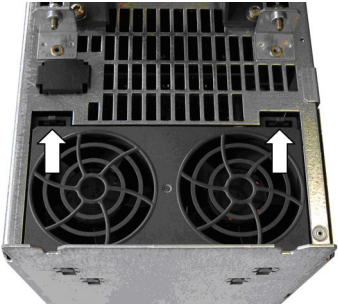
Table 14- 3 Attaching the fan cover on components, sizes 150 mm and 200 mm

Internal air cooling	External air cooling
 <p>1. Fan cover for components with internal air cooling</p>	 <p>1. Fan cover with three mounting lugs for components with external air cooling</p>
 <p>2. Attach the fan cover.</p>	 <p>2. Attach the fan cover (the lugs first).</p>
 <p>3. Press on the fan cover until the catches engage.</p>	 <p>3. Press on the fan cover until the catches engage.</p>

Replacing the fan for components, size 300 mm

Installing the fan module on 300 mm wide components is described in the associated Chapter "Installation (Page 150)".

The fan module is removed in the inverse sequence to installing.

14.2.3 Replacing the fan on an Active Interface Module

For Active Interface Modules, the fan and fan cover are designed as one compact unit. Active Interface Modules 16 kW, 36 kW and 55 kW each have one fan, Active Interface Modules 80 kW and 120 kW have 2 fans. Removal and installation are the same for all module types. Removal based on an 80 kW module is described below.

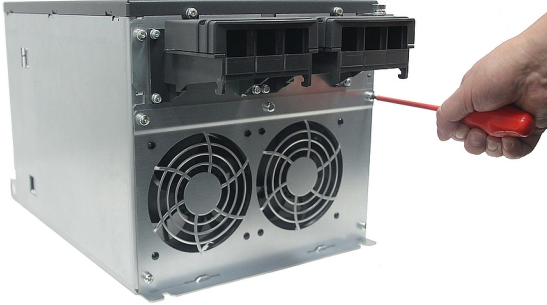
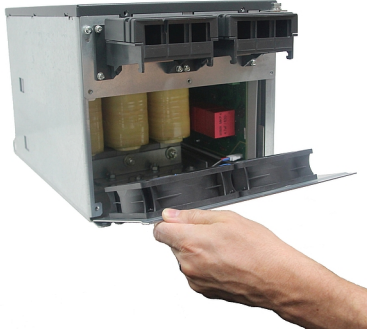
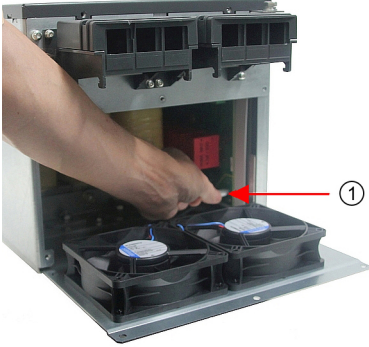
	
<p>1. Open the fan cover. To do this, release the combination screws M5 (3.5 Nm / 31.0 lbf in).</p>	<p>2. Open the fan cover.</p>
	
<p>3. Release the connector ①.</p>	

To install, carry out the above steps in reverse order. The torques must be carefully observed.

14.2.4 Replacing the fan on the 100 kW Basic Line Module for capacitor cooling

Table 14- 4 Removing the fan

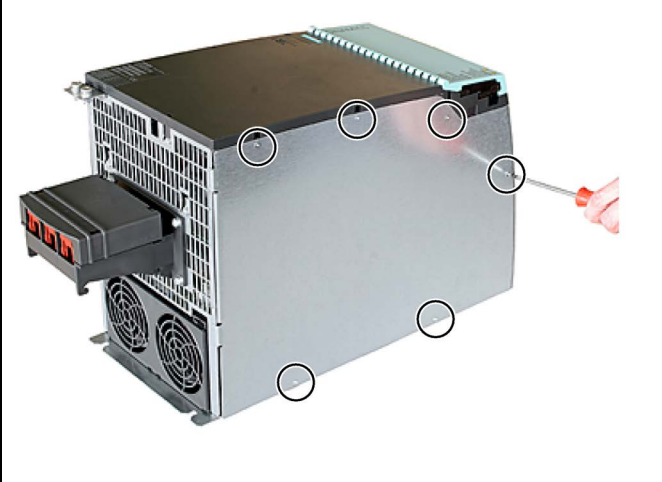
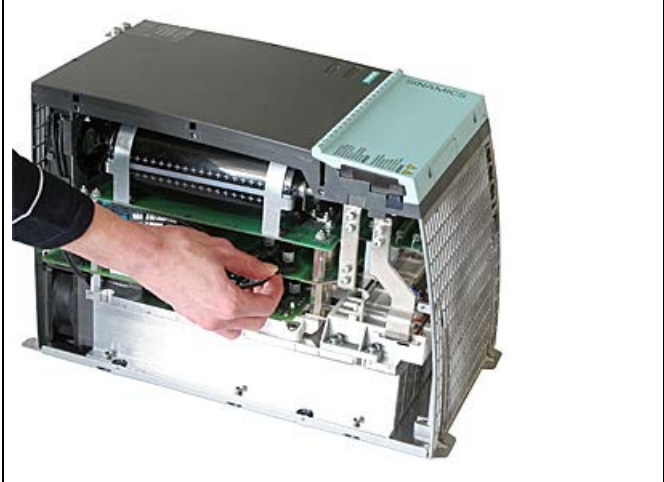
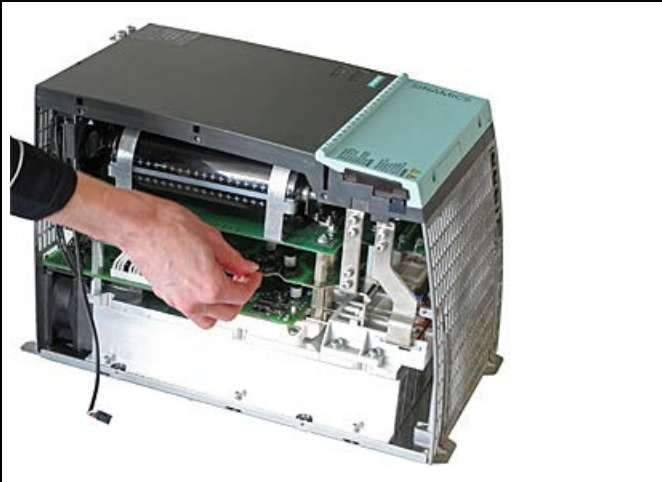
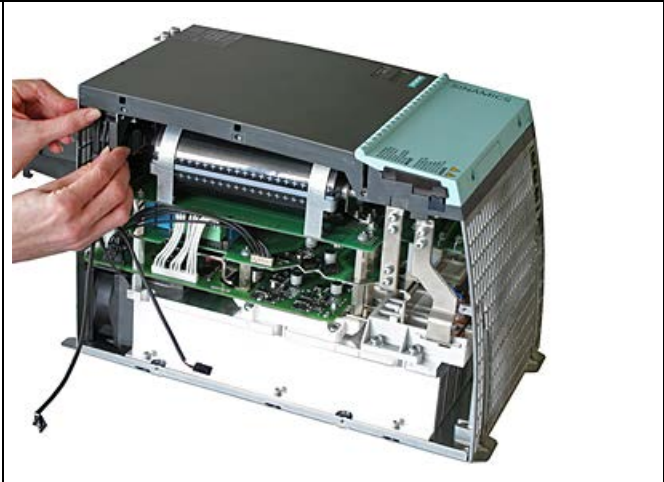
	
<p>1. Open the right housing cover by loosening the 6 marked screws.</p>	<p>2. Withdraw the first fan cable by lightly pressing the connector together.</p>
	
<p>3. Withdraw the second fan cable.</p>	<p>4. Release the fan assembly.</p>





	
<p>5. Completely remove the fan assembly.</p>	<p>6. Slightly expand the fan holding mechanism and remove the fan.</p>

Table 14- 5 Installing a fan

	
<p>1. When using the new fan, observe the marking for the airflow direction.</p>	<p>2. Observe the cable routing.</p>

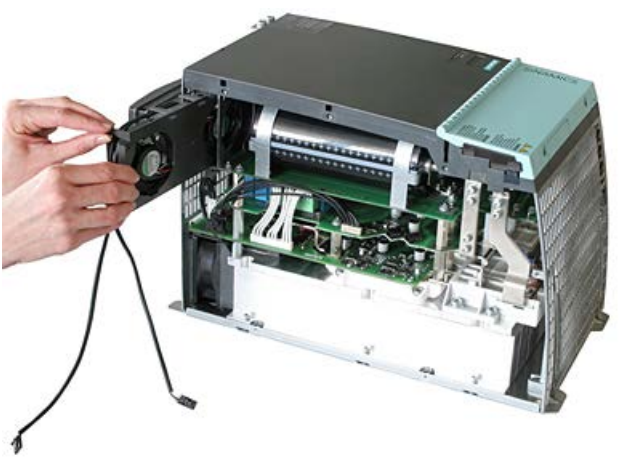
14.2 Replacing the fan

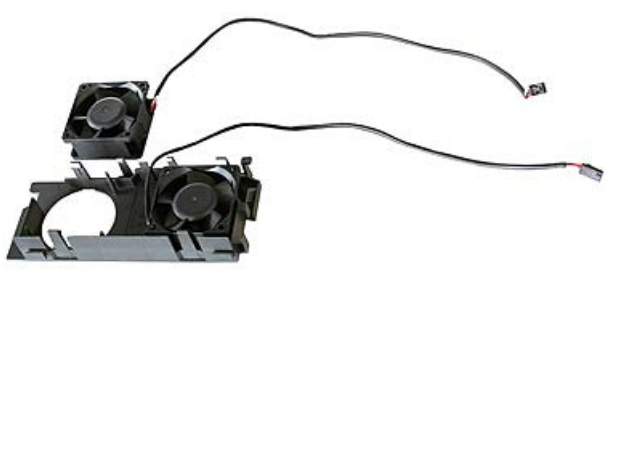
	<p>4. Connect the 2 fan cables.</p> <p>5. Close the housing cover and tighten the 6 screws. Tightening torque: 0.8 Nm (7.1 lbf in)</p>
<p>3. Insert the fan holding mechanism in the guide rails ① and ②.</p>	

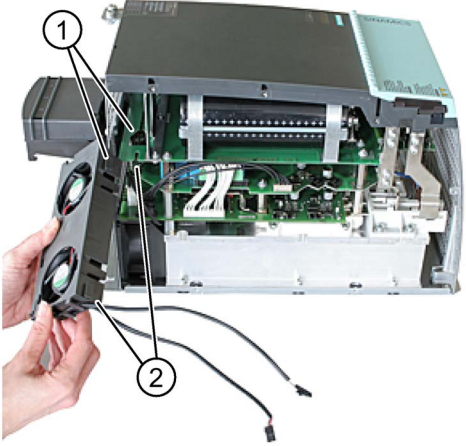
14.2.5 Replacing the fan for Booksize Compact components

Table 14- 6 Removing the fan

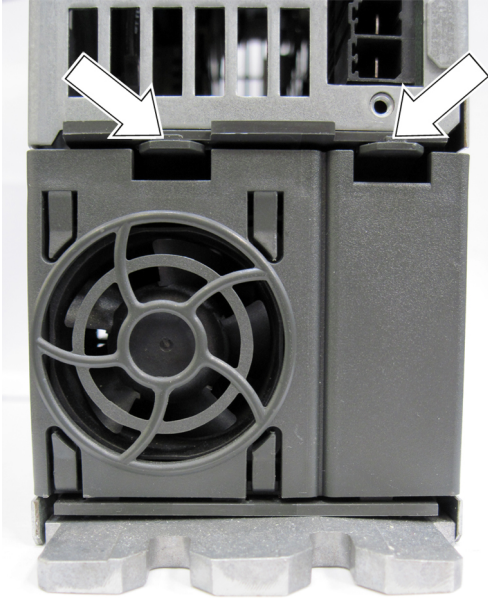
Size 50 mm	Size 75 mm
<p>1. Remove the component from the drive line-up.</p>	
	
<p>2. Remove the fan cover at the lower side of the component by releasing the catches.</p>	

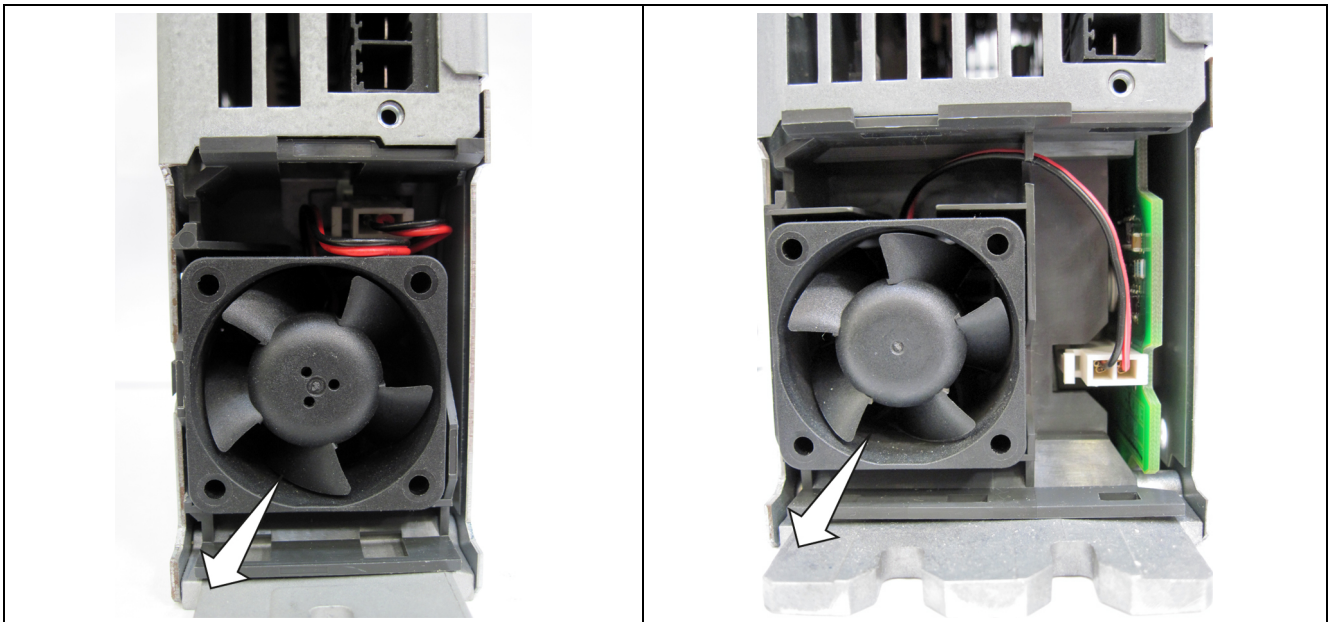

3. Carefully withdraw the fan.

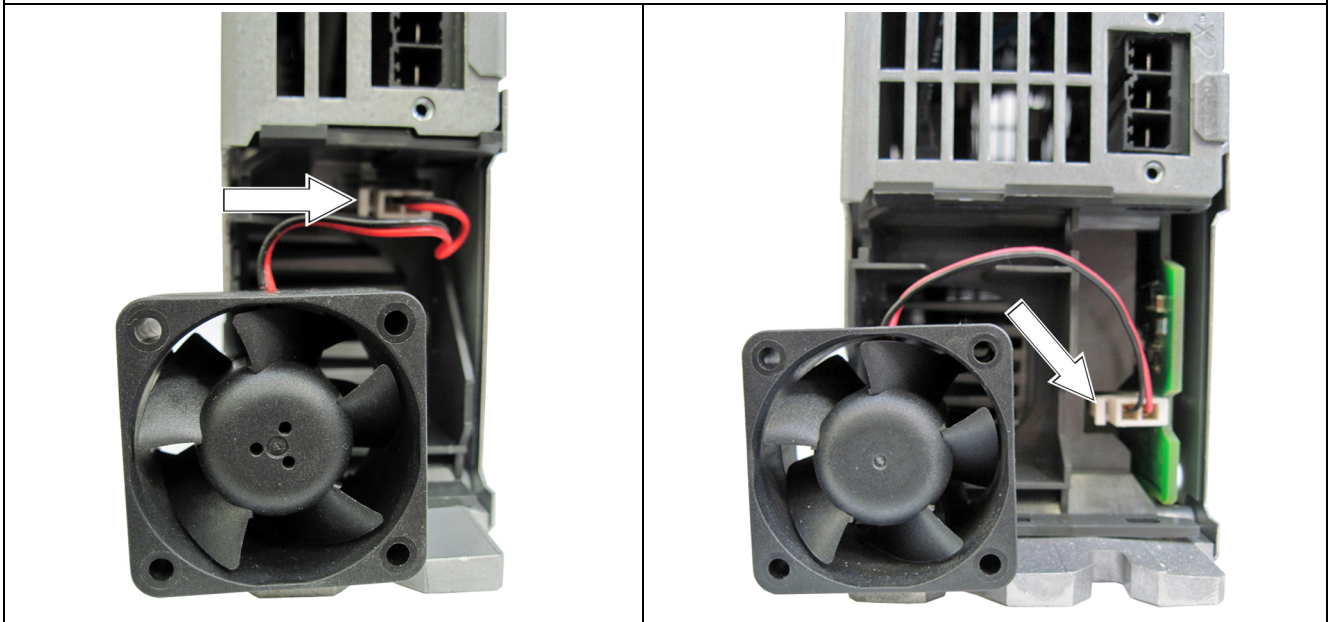

4. Release the connector and remove the connecting cable.

Table 14- 7 Installing a fan

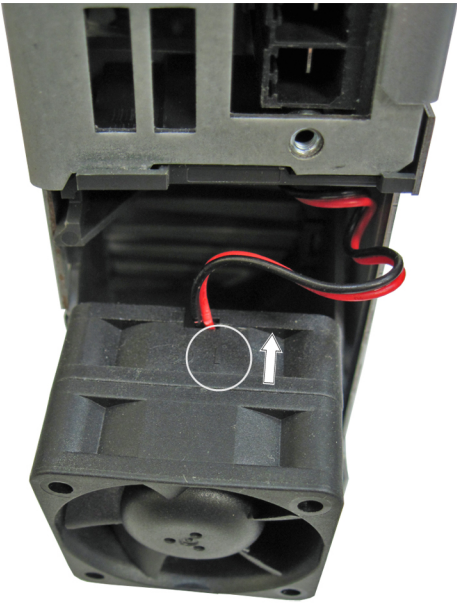
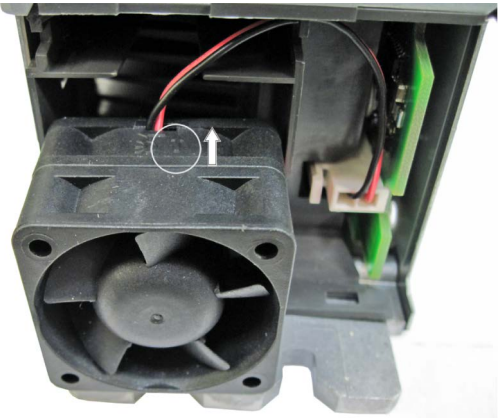
Size 50 mm	Size 75 mm
	
<ol style="list-style-type: none"> 1. Observed the air flow direction before installing the fan (the arrow on the fan must point towards the cooling ribs). 2. Insert the connector until it latches into place. 3. Install the fan. When doing this ensures that the connecting cables are not crushed. 4. Attach the fan cover. 	

14.3 Forming the DC link capacitors

Description

If the Line Modules and Motor Modules are kept in storage for more than two years, the DC-link capacitors have to be reformed. If this is not performed, the units could be damaged when they are switched on.

If the cabinet is commissioned within two years of its date of manufacture, the DC-link capacitors do not need to be reformed. The date of manufacture can be taken from the serial number on the rating plate.

Note

The storage period is calculated from the date of manufacture and not from the date that the equipment was shipped.

Rating plate

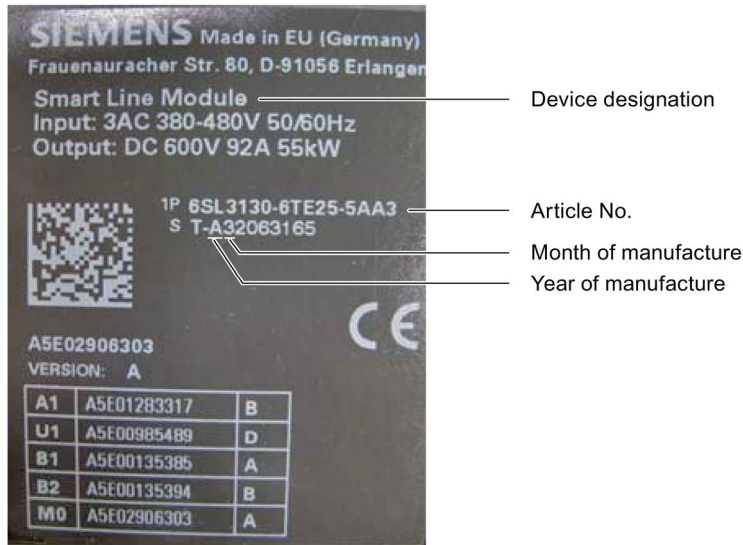

Figure 14-1 Rating plate using a Smart Line Module as example

Date of manufacture

The date of manufacture can be determined as follows:

Table 14- 8 Production year and month

Character	Year of manufacture	Character	Month of manufacture
A	2010	1 ... 9	January to September
B	2011	O	October
C	2012	N	November
D	2013	D	December
E	2014		
F	2015		
H	2016		
J	2017		
K	2018		
L	2019		
M	2020		

The serial number is found on the rating plate.

Forming circuit

A defined voltage and a limited current are applied to the DC-link capacitors when forming them. As a consequence, the internal relationships required for the DC-link capacitors to function correctly are re-established.

The forming circuit is set up using PTC resistors, or alternatively incandescent lamps.

Components required (recommendation)

- 1 fuse switch 3-phase 400 V / 10 A
- Cable 1.5 mm²
- 3 PTC resistors 350 Ω / 35 W
(recommendation: PTC-35W PTC800620-350 Ohm, Michael Koch GmbH)
- Alternative to PTC resistors: 3 incandescent lamps 230 V / 100 W
- Various small components, such as lamp socket, etc.



 WARNING
Electric shock due to the residual charge of the DC-link capacitors
Due to the DC-link capacitors, a hazardous voltage is present in the DC link for up to five minutes after the power supply has been switched off.
Contact with live parts can result in death or serious injury.
<ul style="list-style-type: none">• Do not open the protective cover of the DC link until 5 minutes have elapsed.• Check that the cabinet is de-energized.

Note

Line Modules are formed by means of a connected Motor Module. See Forming circuits of Line Modules.

Interface for Line Modules

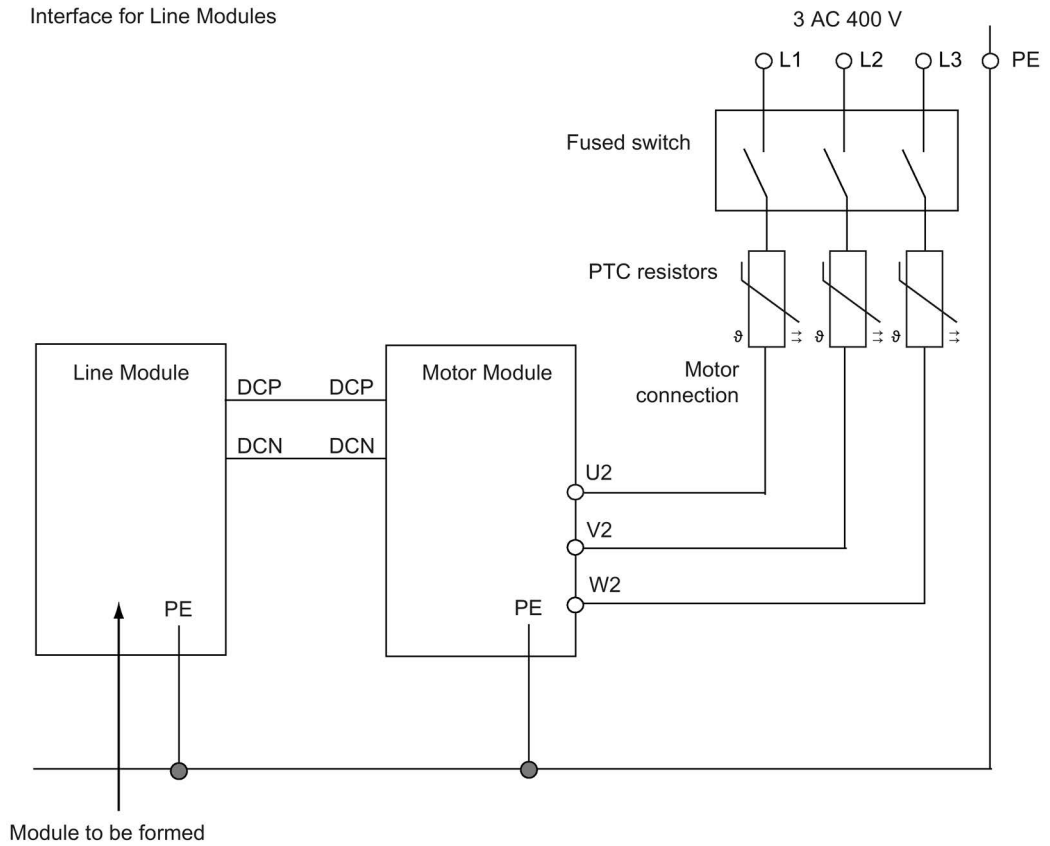

Figure 14-2 Forming circuit for Line Modules with PTC resistors

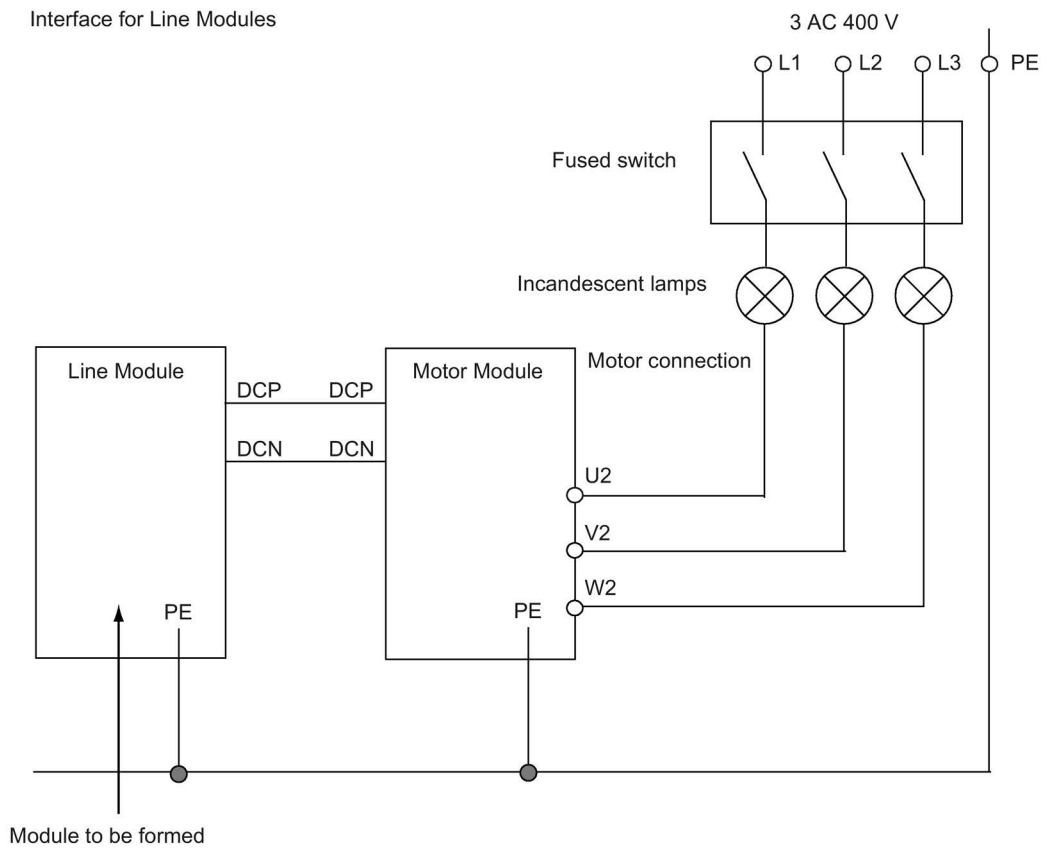

Figure 14-3 Forming circuit for Line Modules with incandescent lamps

Interface for Motor Modules

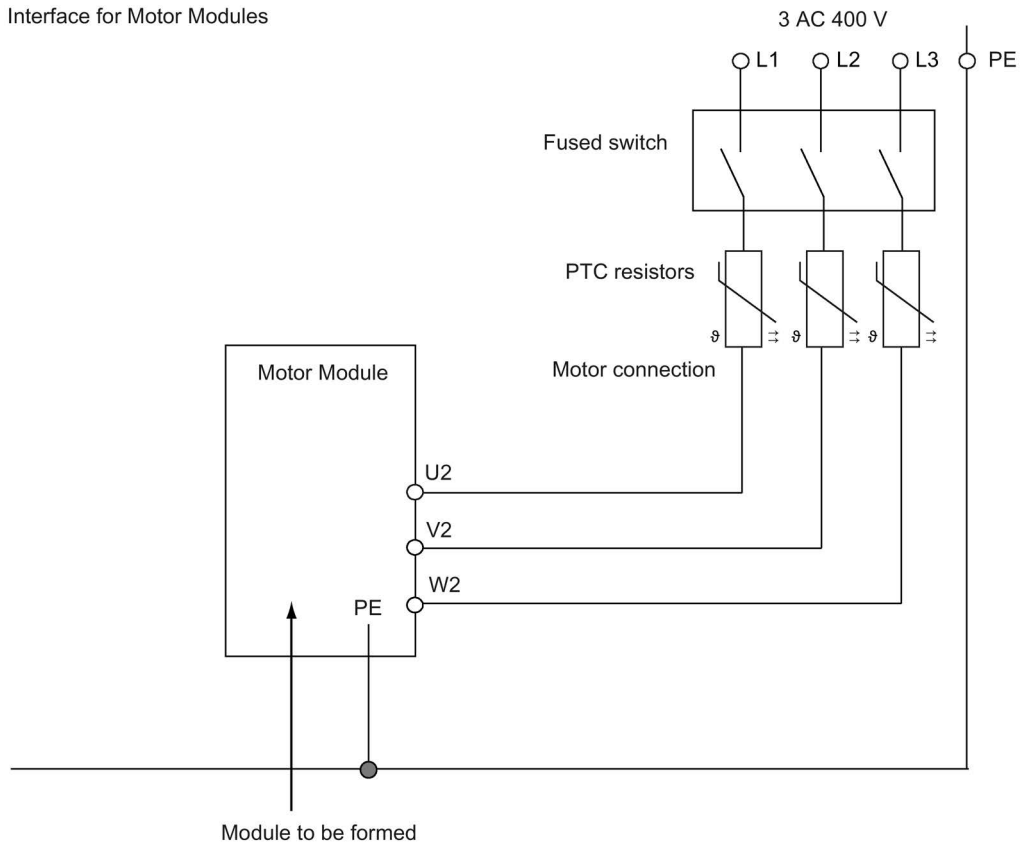

Figure 14-4 Forming circuit for Motor Modules with PTC resistors

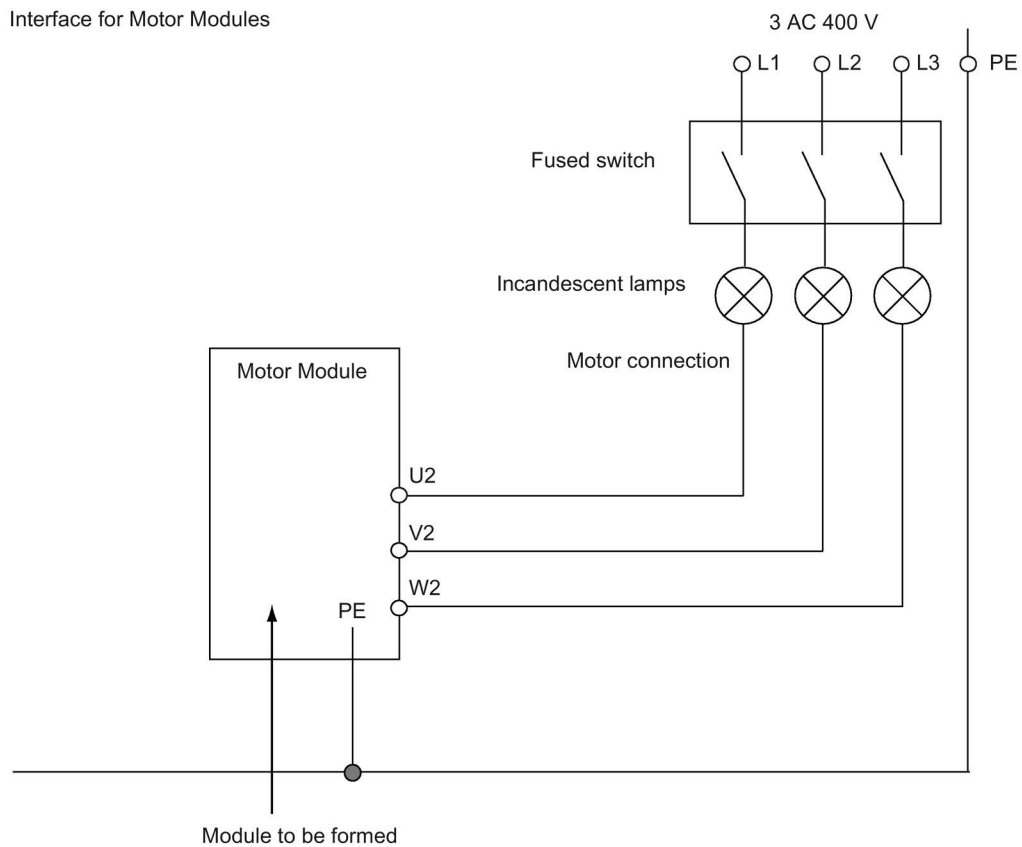

Figure 14-5 Forming circuit for Motor Modules with incandescent lamps

Procedure

1. Be sure to remove the DC-link bridge before forming the DC-link capacitors.
2. Make sure that the device **does not** receive a switch-on command (e.g. from the keyboard, BOP20 or terminal block).
3. Connect the forming circuit.

For forming using PTC resistors, the modules must remain in the circuit for approx. 1h. The resistors will become very hot if there is a fault in the unit (surface temperature > 80° C).

While forming, the incandescent lamps must go dark or go out completely. If the incandescent lamps continue to be brightly lit, a fault has occurred in the drive unit or in the wiring.

14.4 Recycling and disposal

Dispose of the product according to the applicable national regulations.

The products described in this Equipment Manual are extensively recyclable on account of the low-toxic composition of the materials used. To recycle and dispose of your old device in an environmentally friendly way, please contact a company that disposes of electronic waste.

Appendix

A.1 List of abbreviations

Note

The following list of abbreviations includes all abbreviations and their meanings used in the entire SINAMICS family of drives.

Abbreviation	Source of abbreviation	Meaning
A		
A...	Alarm	Warning
AC	Alternating Current	Alternating current
ADC	Analog Digital Converter	Analog digital converter
AI	Analog Input	Analog input
AIM	Active Interface Module	Active Interface Module
ALM	Active Line Module	Active Line Module
AO	Analog Output	Analog output
AOP	Advanced Operator Panel	Advanced Operator Panel
APC	Advanced Positioning Control	Advanced Positioning Control
AR	Automatic Restart	Automatic restart
ASC	Armature Short-Circuit	Armature short-circuit
ASCII	American Standard Code for Information Interchange	American coding standard for the exchange of information
AS-i	AS-Interface (Actuator Sensor Interface)	AS-Interface (open bus system in automation technology)
ASM	Asynchronmotor	Induction motor
AVS	Active Vibration Suppression	Active load vibration damping
B		
BB	Betriebsbedingung	Operation condition
BERO	-	Contactless proximity switch
BI	Binector Input	Binector input
BIA	Berufsgenossenschaftliches Institut für Arbeitssicherheit	BG Institute for Occupational Safety and Health
BICO	Binector Connector Technology	Binector connector technology
BLM	Basic Line Module	Basic Line Module
BO	Binector Output	Binector output
BOP	Basic Operator Panel	Basic operator panel
C		
C	Capacitance	Capacitance

A.1 List of abbreviations

C...	-	Safety message
CAN	Controller Area Network	Serial bus system
CBC	Communication Board CAN	Communication Board CAN
CBE	Communication Board Ethernet	PROFINET communication module (Ethernet)
CD	Compact Disc	Compact disc
CDS	Command Data Set	Command data set
CF Card	CompactFlash Card	CompactFlash card
CI	Connector Input	Connector input
CLC	Clearance Control	Clearance control
CNC	Computerized Numerical Control	Computer-supported numerical control
CO	Connector Output	Connector output
CO/BO	Connector Output/Binector Output	Connector/binector output
COB-ID	CAN Object-Identification	CAN Object Identification
CoL	Certificate of License	Certificate of License
COM	Common contact of a change-over relay	Center contact of a change-over contact
COMM	Commissioning	Startup
CP	Communication Processor	Communications processor
CPU	Central Processing Unit	Central processing unit
CRC	Cyclic Redundancy Check	Cyclic redundancy check
CSM	Control Supply Module	Control Supply Module
CU	Control Unit	Control Unit
CUA	Control Unit Adapter	Control Unit Adapter
CUD	Control Unit DC	Control Unit DC
D		
DAC	Digital Analog Converter	Digital analog converter
DC	Direct Current	Direct current
DCB	Drive Control Block	Drive Control Block
DCBRK	DC Brake	DC braking
DCC	Drive Control Chart	Drive Control Chart
DCN	Direct Current Negative	Direct current negative
DCP	Direct Current Positive	Direct current positive
DDC	Dynamic Drive Control	Dynamic Drive Control
DDS	Drive Data Set	Drive Data Set
DI	Digital Input	Digital input
DI/DO	Digital Input/Digital Output	Digital input/output, bidirectional
DMC	DRIVE-CLiQ Hub Module Cabinet	DRIVE-CLiQ Hub Module Cabinet
DME	DRIVE-CLiQ Hub Module External	DRIVE-CLiQ Hub Module External
DMM	Double Motor Module	Double Motor Module
DO	Digital Output	Digital output
DO	Drive Object	Drive object
DP	Decentralized Peripherals	Distributed I/O
DPRAM	Dual Ported Random Access Memory	Dual-Port Random Access Memory
DQ	DRIVE-CLiQ	DRIVE-CLiQ

DRAM	Dynamic Random Access Memory	Dynamic Random Access Memory
DRIVE-CLiQ	Drive Component Link with IQ	Drive Component Link with IQ
DSC	Dynamic Servo Control	Dynamic Servo Control
DSM	Doppelsubmodul	Double submodule
DTC	Digital Time Clock	Timer
E		
EASC	External Armature Short-Circuit	External armature short-circuit
EDS	Encoder Data Set	Encoder data set
EEPROM	Electrically Erasable Programmable Read-Only Memory	Electrically Erasable Programmable Read-Only Memory
EGB	Elektrostatisch gefährdete Baugruppen	Electrostatic sensitive devices
ELCB	Earth Leakage Circuit Breaker	Residual current operated circuit breaker
ELP	Earth Leakage Protection	Ground-fault monitoring
EMC	Electromagnetic Compatibility	Electromagnetic compatibility
EMF	Electromotive Force	Electromotive force
EMK	Elektromotorische Kraft	Electromotive force
EMV	Elektromagnetische Verträglichkeit	Electromagnetic compatibility
EN	Europäische Norm	European standard
EnDat	Encoder-Data-Interface	Encoder interface
EP	Enable Pulses	Pulse enable
EPOS	Einfachpositionierer	Basic positioner
ES	Engineering System	Engineering system
ESB	Ersatzschaltbild	Equivalent circuit diagram
ESD	Electrostatic Sensitive Devices	Electrostatic sensitive devices
ESM	Essential Service Mode	Essential service mode
ESR	Extended Stop and Retract	Extended stop and retract
F		
F...	Fault	Fault
FAQ	Frequently Asked Questions	Frequently Asked Questions
FBLOCKS	Free Blocks	Free function blocks
FCC	Function Control Chart	Function control chart
FCC	Flux Current Control	Flux current control
FD	Function Diagram	Function diagram
F-DI	Failsafe Digital Input	Fail-safe digital input
F-DO	Failsafe Digital Output	Fail-safe digital output
FEPRM	Flash-EPRM	Non-volatile write and read memory
FG	Function Generator	Function generator
FI	-	Fault current
FOC	Fiber-Optic Cable	Fiber-optic cable
FP	Funktionsplan	Function diagram
FPGA	Field Programmable Gate Array	Field Programmable Gate Array
FW	Firmware	Firmware
G		

GB	Gigabyte	Gigabyte
GC	Global Control	Global control telegram (broadcast telegram)
GND	Ground	Reference potential for all signal and operating voltages, usually defined as 0 V (also referred to as M)
GSD	Gerätstammdatei	Generic Station Description: Describes the features of a PROFIBUS slave
GSV	Gate Supply Voltage	Gate supply voltage
GUID	Globally Unique Identifier	Globally Unique Identifier
H		
HF	High frequency	High frequency
HFD	Hochfrequenzdrossel	Radio frequency reactor
HLA	Hydraulic Linear Actuator	Hydraulic linear actuator
HLG	Hochlaufgeber	Ramp-function generator
HM	Hydraulic Module	Hydraulic Module
HMI	Human Machine Interface	Human Machine Interface
HTL	High-Threshold Logic	Logic with high interference threshold
HW	Hardware	Hardware
I		
i. V.	In Vorbereitung	Under development: This property is currently not available
I/O	Input/Output	Input/output
I2C	Inter-Integrated Circuit	Internal serial data bus
IASC	Internal Armature Short-Circuit	Internal armature short-circuit
IBN	Inbetriebnahme	Startup
ID	Identifier	Identification
IE	Industrial Ethernet	Industrial Ethernet
IEC	International Electrotechnical Commission	International Electrotechnical Commission
IF	Interface	Interface
IGBT	Insulated Gate Bipolar Transistor	Insulated gate bipolar transistor
IGCT	Integrated Gate-Controlled Thyristor	Semiconductor power switch with integrated control electrode
IL	Impulslöschung	Pulse suppression
IP	Internet Protocol	Internet Protocol
IPO	Interpolator	Interpolator
IT	Isolé Terre	Non-grounded three-phase line supply
IVP	Internal Voltage Protection	Internal voltage protection
J		
JOG	Jogging	Jogging
K		
KDV	Kreuzweiser Datenvergleich	Data cross-check
KHP	Know-how protection	Know-how protection
KIP	Kinetische Pufferung	Kinetic buffering
Kp	-	Proportional gain

KTY84	-	Temperature sensor
L		
L	-	Symbol for inductance
LED	Light Emitting Diode	Light emitting diode
LIN	Linearmotor	Linear motor
LR	Lageregler	Position controller
LSB	Least Significant Bit	Least significant bit
LSC	Line-Side Converter	Line-side converter
LSS	Line-Side Switch	Line-side switch
LU	Length Unit	Length unit
LWL	Lichtwellenleiter	Fiber-optic cable
M		
M	-	Symbol for torque
M	Masse	Reference potential for all signal and operating voltages, usually defined as 0 V (also referred to as GND)
MB	Megabyte	Megabyte
MCC	Motion Control Chart	Motion Control Chart
MDI	Manual Data Input	Manual data input
MDS	Motor Data Set	Motor data set
MLFB	Maschinenlesbare Fabrikatebezeichnung	Machine-readable product code
MM	Motor Module	Motor Module
MMC	Man-Machine Communication	Man-machine communication
MMC	Micro Memory Card	Micro memory card
MSB	Most Significant Bit	Most significant bit
MSC	Motor-Side Converter	Motor-side converter
MSCY_C1	Master Slave Cycle Class 1	Cyclic communication between master (class 1) and slave
MSR	Motorstromrichter	Motor-side converter
MT	Messtaster	Probe
N		
N. C.	Not Connected	Not connected
N...	No Report	No report or internal message
NAMUR	Normenarbeitsgemeinschaft für Mess- und Regeltechnik in der chemischen Industrie	Standardization association for measurement and control in chemical industries
NC	Normally Closed (contact)	NC contact
NC	Numerical Control	Numerical control
NEMA	National Electrical Manufacturers Association	Standardization association in USA (United States of America)
NM	Nullmarke	Zero mark
NO	Normally Open (contact)	NO contact
NSR	Netzstromrichter	Line-side converter
NTP	Network Time Protocol	Standard for synchronization of the time of day
NVRAM	Non-Volatile Random Access Memory	Non-volatile read/write memory

O		
OA	Open Architecture	Software component which provides additional functions for the SINAMICS drive system
OAIF	Open Architecture Interface	Version of the SINAMICS firmware as of which the OA application can be used
OASP	Open Architecture Support Package	Expands the STARTER commissioning tool by the corresponding OA application
OC	Operating Condition	Operation condition
OCC	One Cable Connection	One-cable technology
OEM	Original Equipment Manufacturer	Original equipment manufacturer
OLP	Optical Link Plug	Bus connector for fiber-optic cable
OMI	Option Module Interface	Option Module Interface
P		
p...	-	Adjustable parameters
P1	Processor 1	CPU 1
P2	Processor 2	CPU 2
PB	PROFIBUS	PROFIBUS
PcCtrl	PC Control	Master control
PD	PROFIdrive	PROFIdrive
PDC	Precision Drive Control	Precision Drive Control
PDS	Power unit Data Set	Power unit data set
PDS	Power Drive System	Drive system
PE	Protective Earth	Protective ground
PELV	Protective Extra Low Voltage	Safety extra-low voltage
PFH	Probability of dangerous failure per hour	Probability of dangerous failure per hour
PG	Programmiergerät	Programming device
PI	Proportional Integral	Proportional integral
PID	Proportional Integral Differential	Proportional integral differential
PLC	Programmable Logical Controller	Programmable logic controller
PLL	Phase-Locked Loop	Phase-locked loop
PM	Power Module	Power Module
PMSM	Permanent-magnet synchronous motor	Permanent-magnet synchronous motor
PN	PROFINET	PROFINET
PNO	PROFIBUS Nutzerorganisation	PROFIBUS user organization
PPI	Point to Point Interface	Point-to-point interface
PRBS	Pseudo Random Binary Signal	White noise
PROFIBUS	Process Field Bus	Serial data bus
PS	Power Supply	Power supply
PSA	Power Stack Adapter	Power Stack Adapter
PT1000	-	Temperature sensor
PTC	Positive Temperature Coefficient	Positive temperature coefficient
PTP	Point To Point	Point-to-point
PWM	Pulse Width Modulation	Pulse width modulation
PZD	Prozessdaten	Process data

Q		
R		
r...	-	Display parameters (read-only)
RAM	Random Access Memory	Memory for reading and writing
RCCB	Residual Current Circuit Breaker	Residual current operated circuit breaker
RCD	Residual Current Device	Residual current device
RCM	Residual Current Monitor	Residual current monitor
REL	Reluctance motor textile	Reluctance motor textile
RESM	Reluctance synchronous motor	Synchronous reluctance motor
RFG	Ramp-Function Generator	Ramp-function generator
RJ45	Registered Jack 45	Term for an 8-pin socket system for data transmission with shielded or non-shielded multi-wire copper cables
RKA	Rückkühlanlage	Cooling unit
RLM	Renewable Line Module	Renewable Line Module
RO	Read Only	Read only
ROM	Read-Only Memory	Read-only memory
RPDO	Receive Process Data Object	Receive Process Data Object
RS232	Recommended Standard 232	Interface standard for cable-connected serial data transmission between a sender and receiver (also known as EIA232)
RS485	Recommended Standard 485	Interface standard for a cable-connected differential, parallel, and/or serial bus system (data transmission between a number of senders and receivers, also known as EIA485)
RTC	Real Time Clock	Real-time clock
RZA	Raumzeigerapproximation	Space-vector approximation
S		
S1	-	Continuous operation
S3	-	Intermittent duty
SAM	Safe Acceleration Monitor	Safe acceleration monitoring
SBC	Safe Brake Control	Safe brake control
SBH	Sicherer Betriebshalt	Safe operating stop
SBR	Safe Brake Ramp	Safe brake ramp monitoring
SBT	Safe Brake Test	Safe brake test
SCA	Safe Cam	Safe cam
SCC	Safety Control Channel	Safety Control Channel
SCSE	Single Channel Safety Encoder	Single-channel safety encoder
SD Card	SecureDigital Card	Secure digital memory card
SDC	Standard Drive Control	Standard Drive Control
SDI	Safe Direction	Safe motion direction
SE	Sicherer Software-Endschalter	Safe software limit switch
SESM	Separately-excited synchronous motor	Separately excited synchronous motor
SG	Sicher reduzierte Geschwindigkeit	Safely limited speed
SGA	Sicherheitsgerichteter Ausgang	Safety-related output

A.1 List of abbreviations

SGE	Sicherheitsgerichteter Eingang	Safety-related input
SH	Sicherer Halt	Safe stop
SI	Safety Integrated	Safety Integrated
SIC	Safety Info Channel	Safety Info Channel
SIL	Safety Integrity Level	Safety Integrity Level
SITOP	-	Siemens power supply system
SLA	Safely-Limited Acceleration	Safety limited acceleration
SLM	Smart Line Module	Smart Line Module
SLP	Safely-Limited Position	Safely Limited Position
SLS	Safely-Limited Speed	Safely limited speed
SLVC	Sensorless Vector Control	Sensorless vector control
SM	Sensor Module	Sensor Module
SMC	Sensor Module Cabinet	Sensor Module Cabinet
SME	Sensor Module External	Sensor Module External
SMI	SINAMICS Sensor Module Integrated	SINAMICS Sensor Module Integrated
SMM	Single Motor Module	Single Motor Module
SN	Sicherer Software-Nocken	Safe software cam
SOS	Safe Operating Stop	Safe operating stop
SP	Service Pack	Service pack
SP	Safe Position	Safe position
SPC	Setpoint Channel	Setpoint channel
SPI	Serial Peripheral Interface	Serial peripheral interface
SPS	Speicherprogrammierbare Steuerung	Programmable logic controller
SS1	Safe Stop 1	Safe Stop 1 (time-monitored, ramp-monitored)
SS1E	Safe Stop 1 External	Safe Stop 1 with external stop
SS2	Safe Stop 2	Safe Stop 2
SS2E	Safe Stop 2 External	Safe Stop 2 with external stop
SSI	Synchronous Serial Interface	Synchronous serial interface
SSL	Secure Sockets Layer	Encryption protocol for secure data transfer (new TLS)
SSM	Safe Speed Monitor	Safe feedback from speed monitor
SSP	SINAMICS Support Package	SINAMICS support package
STO	Safe Torque Off	Safe torque off
STW	Steuerwort	Control word
T		
TB	Terminal Board	Terminal Board
TEC	Technology Extension	Software component which is installed as an additional technology package and which expands the functionality of SINAMICS (previously OA application)
TIA	Totally Integrated Automation	Totally Integrated Automation
TLS	Transport Layer Security	Encryption protocol for secure data transfer (previously SSL)
TM	Terminal Module	Terminal Module

TN	Terre Neutre	Grounded three-phase line supply
Tn	-	Integral time
TPDO	Transmit Process Data Object	Transmit Process Data Object
TSN	Time-Sensitive Networking	Time-Sensitive Networking
TT	Terre Terre	Grounded three-phase line supply
TTL	Transistor-Transistor-Logic	Transistor-transistor logic
Tv	-	Rate time
U		
UL	Underwriters Laboratories Inc.	Underwriters Laboratories Inc.
UPS	Uninterruptible Power Supply	Uninterruptible power supply
USV	Unterbrechungsfreie Stromversorgung	Uninterruptible power supply
UTC	Universal Time Coordinated	Universal time coordinated
V		
VC	Vector Control	Vector control
Vdc	-	DC link voltage
VdcN	-	Partial DC link voltage negative
VdcP	-	Partial DC link voltage positive
VDE	Verband Deutscher Elektrotechniker	Verband Deutscher Elektrotechniker [Association of German Electrical Engineers]
VDI	Verein Deutscher Ingenieure	Verein Deutscher Ingenieure [Association of German Engineers]
VPM	Voltage Protection Module	Voltage Protection Module
Vpp	Volt peak to peak	Volt peak to peak
VSM	Voltage Sensing Module	Voltage Sensing Module
W		
WEA	Wiedereinschaltautomatik	Automatic restart
WZM	Werkzeugmaschine	Machine tool
X		
XML	Extensible Markup Language	Extensible markup language (standard language for Web publishing and document management)
Y		
Z		
ZK	Zwischenkreis	DC link
ZM	Zero Mark	Zero mark
ZSW	Zustandswort	Status word

A.2 Documentation overview

General documentation/catalogs			
SINAMICS	G110	D 11	- Converter built-in units 0.12 kW up to 3 kW
	G120	D 31	- SINAMICS Converters for Single-Axis Drives and SIMOTICS Motors
	G130, G150	D 11	- Converter built-in units - Converter cabinet units
	S120, S150	D 21	- SINAMICS S120 built-in units in the chassis format and Cabinet Modules - SINAMICS S150 Converter Cabinet Units
	S120	D 21.4	- SINAMICS S120 and SIMOTICS
Manufacturer/service documentation			
SINAMICS	G110		- Getting Started - Operating instructions - List Manuals
	G120		- Getting Started - Operating instructions - Hardware Installation Manuals - Function Manual Safety Integrated - List Manuals
	G130		- Operating instructions - List Manual
	G150		- Operating instructions - List Manual
	GM150, SM120/SM150, GL150, SL150		- Operating instructions - List Manuals
	S110		- Manual - Getting Started - Function Manual - List Manual
	S120		- Getting Started with STARTER - Commissioning Manual with STARTER - Getting Started with Startdrive - Commissioning Manual with Startdrive - Commissioning Manual CANopen - Function Manual Drive Functions - Function Manual Safety Integrated - Function Manual DCC - List Manual - Manual Control Unit and supplementary system components - Manual Power Unit Booksize - Manual Power Unit Booksize C/D Type - Manual Power Unit Chassis air-cooled - Manual Power Unit Chassis liquid-cooled - Combi Manual - Manual Cabinet Modules - Manual AC Drive - SINAMICS S120M Manual Distributed Drive Technology - SINAMICS HLA System Manual Hydraulic Drive
	S150		- Operating instructions - List Manual
Motors		- Configuration Manuals, Motors	
General		- Configuration Manual, EMC Guidelines	

Index

A

- Active Interface Module, 101
 - Connecting screw for the interference suppression capacitor, 118, 119
- Active Line Module, 139, 157, 178
- Active Line Module Liquid Cooled, 194
- Addition of biocide, 760
- Anti-condensation measures, 761
- Anti-corrosion agent, 758
- Antifreeze, 759
- Autotransformer, 131

B

- Basic Line Filter for Basic Line Modules, 62
- Basic Line Filter for Smart Line Modules, 67
- Basic Line Filters for Active Line Modules, 56
- Basic Line Module, 206, 225
- Braking duty cycle
 - Basic Line Modules, 224, 246
- Braking Module Booksize, 469
 - Connection example, 474
- Braking Module Booksize Compact, 480
 - Connection example for braking resistor with a thermostatic switch, 489
 - Connection example for braking resistor without a thermostatic switch, 488
- Braking unit 100 kW Basic Line Modules, 497

C

- Cabinet ventilation
 - For cold plate components, 732
- Cable Installation, 712
- Cable lengths
 - Motor reactors, 549
- Cable Shields, 713
- Capacitor Module, 504
- Cavitation, 755
- Center infeed, 651
- Circuit breakers, 47
- Cold plate
 - Drive line-up with external air heat sink, 719
 - Drive line-up with external liquid heat sink, 722
- Cold plate cooling in the drive line-up, 717

Communication

- PROFIBUS DP, 33
- PROFINET, 32

Components

- Active Interface Module, 101
 - Active Line Module, 139, 157, 178
 - Active Line Module Liquid Cooled, 194
 - Basic Line Filter for Basic Line Modules, 62
 - Basic Line Filter for Smart Line Modules, 67
 - Basic Line Filters for Active Line Modules, 56
 - Basic Line Module, 206, 225
 - Braking Module Booksize, 469
 - Braking Module Booksize Compact, 480
 - Braking unit for 100 kW Basic Line Modules, 497
 - Capacitor Module, 504
 - Control Supply Module CSM, 509
 - DC link rectifier adapter, 605
 - DC-link adapter, 617
 - DRIVE-CLiQ cabinet bushing, 631
 - DRIVE-CLiQ coupling, 638
 - Line reactors for Active Line Modules, 75
 - Line reactors for Basic Line Modules, 89
 - Line reactors for Smart Line Modules, 95
 - Motor Module, 333, 363, 398
 - Motor Module Booksize Compact, 441
 - Motor Module Liquid Cooled, 427
 - Smart Line Module booksize compact, 313
 - Smart Line Module with cold plate, 296
 - Smart Line Module with external air cooling, 270
 - Smart Line Module with internal air cooling, 247
 - Voltage Protection Module VPM, 550
- Connecting direct measuring systems with DRIVE-CLiQ ASIC, 688
- Connection examples
- Braking Module Booksize, 474
 - Braking Module Booksize Compact, 488
 - Control Supply Module, 515
- Control cabinet design, 643
- Protective connections, 714
- Control Supply Module
- Connection example, single mode, 517
- Control Supply Module CSM, 509
- Coolant
- Features, 757
- Coolant mix, 753
- Coolant temperatures, 752
- Cooling circuit
- Addition of biocide, 760

- Anti-condensation measures, 761
- Anti-corrosion agent, 758
- Antifreeze, 759
- Configuring, 752
- Dimensioning, 754
- General requirements, 750
- Materials and connections, 754
- Pressure, 752
- Pressure drop, 752
- Cooling circuits, 749
- Current consumption (24 VDC), 677

D

- Damping resistor
 - HFD line reactor, 87
- DC link busbar
 - Connection, 664
 - Overload, 651
- DC link busbars, 599
- DC link connecting cables, 627
 - Connection, 629
 - Fixing to the control cabinet panel, 628
 - Preparation, 627
- DC link rectifier adapter, 605
- DC-link adapter, 617
- DCP/DCN, 662, 664
- Derating
 - Active Line Modules Liquid Cooled, 205
 - Motor Modules Booksize, 355, 391, 420
 - Motor Modules Booksize (300% overload), 361, 397, 426
 - Motor Modules Booksize Compact, 464
 - Motor Modules Booksize Liquid Cooled, 439
- Diagnostics via LEDs
 - Active Line Modules, 145, 163, 184, 200
 - Basic Line Modules, 215, 234
 - Braking Module Booksize, 475
 - Braking Module Booksize Compact, 490
 - Control Supply Module, 523
 - Motor Module booksize compact, 452
 - Motor Module Liquid Cooled, 433
 - Motor Modules, 343, 373, 408
 - Smart Line Module Booksize Compact, 322
 - Smart Line Modules 16 kW and higher, 261, 284
 - Smart Line Modules 5 kW and 10 kW, 260, 284, 304
- Dimension drawings
 - Active Interface Module internal air cooling, 110
 - Active Line Module Liquid Cooled, 201
 - Active Line Module with external air cooling, 164
 - Active Line Modules with cold plate, 185

- Active Line Modules with internal air cooling, 146
- Basic Line Filter for Basic Line Modules, 64
- Basic Line Filter for Smart Line Modules, 69
- Basic Line Filters for Active Line Modules, 58
- Basic Line Module with cold plate, 235
- Basic Line Module with internal air cooling, 216
- Braking Module Booksize, 476
- Braking Module Booksize Compact, 491
- Braking resistors for Braking Modules and Basic Line Modules, 531
- Control Supply Module, 524
- Damping resistor, 86
- DC link rectifier adapter, 609
- DRIVE-CLiQ cabinet bushing, 633
- DRIVE-CLiQ coupling, 639
- Line reactors for Active Line Modules, 79
- Line reactors for Basic Line Modules, 92
- Line reactors for Smart Line Modules, 97
- Masterdrives braking unit for Basic Line Module, 501
- Motor Module Booksize with cold plate, 409
- Motor Module Booksize with external air cooling, 374
- Motor Module Booksize with internal air cooling, 344
- Motor Module Liquid Cooled, 434
- Motor Modules Booksize Compact, 453
- Shield connecting plates on Active Interface Modules, 589
- Shield connecting plates, components, cold plate, 584
- Shield connecting plates, components, external air cooling, 580
- Shield connecting plates, components, internal air cooling, 576
- Shield connecting plates, components, Liquid Cooled, 588
- Smart Line Module with external air cooling, 285
- Smart Line Module with internal air cooling, 262
- Smart Line Modules, 305
- Voltage Protection Module VPM, 559
- Dimension Drawings
 - Capacitor Module, 506
 - DC link adapter, 622
- Disconnecter unit, 46
- Drive line-up
 - Multi-tier, 654
- Drive Line-Up
 - Single tier, 652
- DRIVE-CLiQ, 35
- DRIVE-CLiQ cabinet bushing, 631
- DRIVE-CLiQ coupling, 638

- DRIVE-CLiQ signal cables, 683
 - Combined use of MC500 and MC800 PLUS, 689
 - Connection of direct measuring systems, 688
 - Properties, 687
- Duty cycles
 - Braking Module Booksize, 478
 - Braking Module Booksize Compact, 495
 - Braking resistors, 539
- E**
- Electrical connection, 629
- Electrical connections
 - 24 V busbars, 667
 - DC link busbars, 664
 - DC link rectifier adapter, 615
- Electronic rating plate, 35
- EMC category, 645
- EMC environment, 645
- Environmental conditions, 43
- Equipotential bonding, 714, 716
- F**
- Field of application, 31
- H**
- Heat dissipation, 724
- I**
- Installation
 - 24 V terminal adapter, 668
 - Active Interface Module (internal cooling), 114
 - Active Line Module Liquid Cooled, 203
 - Active Line Module with external air cooling, 167
 - Active Line Modules with internal air cooling, 150, 349
 - Basic Line Module with cold plate, 238
 - Basic Line Module with internal air cooling, 219
 - Braking Module Booksize, 477
 - Braking Module Booksize Compact, 492
 - DC link adapter, 623
 - DC link rectifier adapter on components that are between 50 and 100 mm wide, 611
 - DC link rectifier adapter on components that are more than 150 mm wide, 613
 - DRIVE-CLiQ cabinet bushing, 635
 - DRIVE-CLiQ coupling, 639
 - Motor Module Booksize Compact, 456
 - Motor Module Booksize with cold plate, 413
 - Motor Module Liquid Cooled, 436
 - Motor Module with External Air Cooling, 379
 - Reinforced DC link busbars, 603
 - Smart Line Module with cold plate, 306
 - Smart Line Module with external air cooling, 289
 - Voltage Protection Module VPM, 561
- Interface descriptions
 - Active Interface Module (internal cooling), 104
 - Active Line Module Liquid Cooled, 195
 - Active Line Module with cold plate, 179
 - Active Line Module with external air cooling, 158
 - Active Line Modules with internal air cooling, 140
 - Basic Line Filters for Active Line Modules, 57
 - Basic Line Module with cold plate, 226
 - Basic Line Module with internal air cooling, 207
 - Braking Module Booksize, 471
 - Braking Module Booksize Compact, 483
 - Braking unit for 100 kW Basic Line Modules, 498
 - Control Supply Module, 512
 - DC link adapter, 620
 - DRIVE-CLiQ cabinet bushing, 632
 - DRIVE-CLiQ cabinet bushing M12, 632
 - DRIVE-CLiQ coupling, 638
 - Line reactors for Active Line Modules, 75
 - Line reactors for Basic Line Modules, 89
 - Line reactors for Smart Line Modules, 95
 - Motor Module Booksize with cold plate, 399
 - Motor Module Booksize with external air cooling, 364
 - Motor Module Booksize with internal air cooling, 334
 - Motor Module Liquid Cooled, 428
 - Motor Modules Booksize Compact, 445
 - Smart Line Module Booksize Compact, 317
 - Smart Line Module with cold plate (5 kW and 10 kW), 299
 - Smart Line Module with external air cooling, 273
 - Smart Line Module with internal air cooling, 249
- Introduction, 34
- Isolating transformer, 132
- IT line system, 118
- L**
- LEDs
 - Active Line Modules, 145, 163, 184, 200
 - Basic Line Modules, 215, 234
 - Braking Module Booksize, 475
 - Braking Module Booksize Compact, 490
 - Control Supply Module, 523

- Motor Module booksize compact, 452
- Motor Module Liquid Cooled, 433
- Motor Modules, 343, 373, 408
- Smart Line Module Booksize Compact, 322
- Smart Line Modules 16 kW and higher, 261, 284
- Smart Line Modules 5 kW and 10 kW, 260, 284, 304

- Line connection, 45
- Line connection options, 123
- Line connection voltage, 42
- Line contactor, 52
- Line frequency, 42
- Line reactors, 73
- Line reactors for Active Line Modules, 75
- Line reactors for Basic Line Modules, 89
- Line reactors for Smart Line Modules, 95

M

- Motor connection connector
 - Coding, 707
 - Removal, 705
 - With locking mechanism, 698
- Motor Module, 333, 363, 398
- Motor Module Booksize Compact, 441
- Motor Module Liquid Cooled, 427
- Motor overload protection, 332, 444
- Motor plug connector, 698
- Motor reactors, 541
- Mounting
 - Capacitor Module, 507
 - Control Supply Module, 525
 - DRIVE-CLiQ cabinet bushing M12, 636
 - Motor Module Booksize with cold plate, 187
 - Motor Module with internal air cooling, 350
 - Smart Line Module Booksize Compact, 324
- MRCD
 - Residual current protection device, 50

O

- Overcurrent, 674
- Overcurrent trip, 332, 444

P

- Platform Concept, 32
- Power connector, 698
- Power loss, 734
- Power loss calculation, 733
- Power Supply Units, 682

- PROFIBUS DP, 33
- PROFINET, 32
- Protection class, 43
- Protective connections, 714

R

- Rated duty cycles, 359, 395, 424
 - Active Line Modules, 155, 176, 192
 - Active Line Modules Liquid Cooled, 205
 - Active Line Modules with Active Interface Modules, 156, 177, 193
 - Basic Line Modules, 223, 245
 - Motor Modules Booksize, 354, 389, 419
 - Motor Modules Booksize Compact, 462
 - Motor Modules Booksize Liquid Cooled, 437
 - Motor Modules Booksize with 300% overload, 359, 395, 424
 - Smart Line Modules, 269, 296, 310
 - Smart Line Modules booksize compact, 328
- Rated pulse frequency, 43
- Rated short-circuit current, 42
- Reinforced DC link busbars, 599
- Residual current devices, 48
- Residual current protection device, 50

S

- Safety instructions
 - Control cabinet design, 644
- Shield connection
 - For terminals X21/X22 on Motor Modules, 670
- Smart Line Module booksize compact, 313
- Smart Line Module with cold plate, 296
- Smart Line Module with external air cooling, 270
- Smart Line Module with internal air cooling, 247
- Spacing bolts for Motor Module in compact booksize format, 640
- System architecture, 35

T

- Technical data
 - Active Interface Module internal air cooling, 120
 - Active Line Module Liquid Cooled, 203
 - Active Line Modules, cold plate, 190
 - Active Line Modules, external air cooling, 173
 - Active Line Modules, internal air cooling, 152
 - Basic Line Filter for Basic Line Modules, 66
 - Basic Line Filter for Smart Line Modules, 71
 - Basic Line Filters for Active Line Modules, 61

- Basic Line Modules, 222
- Basic Line Modules with cold plate, 243
- Braking Module Booksize, 478
- Braking Module Booksize Compact, 494
- Braking resistors, 537
- Capacitor Module, 508
- Control Supply Module, 526
- DC link adapter, 631
- DC link rectifier adapter, 616
- DRIVE-CLiQ cabinet bushings, 637
- DRIVE-CLiQ coupling, 640
- Electronics power supply, 42
- Line reactors for Active Line Modules, 84
- Line reactors for Basic Line Modules, 95
- Line reactors for Smart Line Modules, 100
- Motor Modules Booksize Compact, 459
- Motor Modules Cold Plate (3-fold overload), 422
- Motor Modules Liquid Cooled, 436
- Motor Modules with cold plate, 416
- Motor Modules with external air cooling, 386
- Motor Modules with internal air cooling, 351
- Motor Modules, external air cooling (3-fold overload), 392
- Motor Modules, internal air cooling (3-fold overload), 357
- Motor reactors, 548
- Smart Line Modules Booksize Compact, 326
- Smart Line Modules with cold plate, 308
- Smart Line Modules with external air cooling, 294
- Smart Line Modules with internal air cooling, 267
- Voltage Protection Module VPM, 568
- Temperature limits, 732
- Temperature measurement, 732
- Totally Integrated Automation, 32

V

- Ventilation, 724
- Voltage Protection Module VPM, 550

Further information

Siemens:

www.siemens.com

Industry Online Support (service and support):

www.siemens.com/online-support

IndustryMall:

www.siemens.com/industrymall

Siemens AG

Digital Factory

Motion Control

P.O. Box 3180

91050 Erlangen

Germany

Scan the QR-Code
for product
information

